

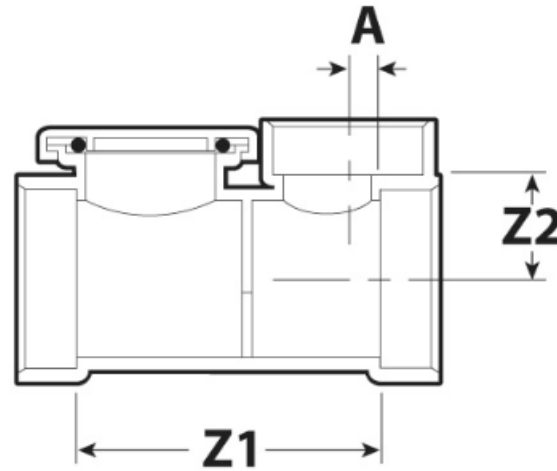

Part Description:
25gpm Compact Flow Control Device, 2" x
2" x 1.5" (HxHxH), PVC (Grey)

Part Number:
3922125CA

Approvals and Listings maintained by:
Canplas Industries Ltd
Canada: 1-800-461-5300 USA: 1-888-461-5307



Part #	Part UPC	Colour	Size (inches)	Ctn Qty	Ctn Bar Code	Ctn. Wt (Kgs)	Ctn. Wt (lbs)	Skid Cubic (m)	Skid Cubic (ft)	Ctns/Skid
3922125CA	862671071422	GREY		1	10700000000000					
Dimensions (inches)										
A	Z1	Z2								
0.356	3.042	1.426								