

RADA V12 THERMOSTATIC SHOWER VALVE



- Buildcert TMV3 Scheme Approved
- WRAS Approved
- Single sequential operation from off through cold to warm
- Light touch control complemented by easy to understand graphics to address the needs of all users irrespective of age or ability
- Robust construction to withstand heavy usage in the commercial environment
- Optional 6 l/min flow regulator for increased water savings. A 9 l/min flow regulator is also supplied
- Safe-to-touch. The V12 Exposed option features Insutech® technology to reduce surface temperature to a safe level
- Easy access to filters for servicing.



Dimensions (mm)

Concealed

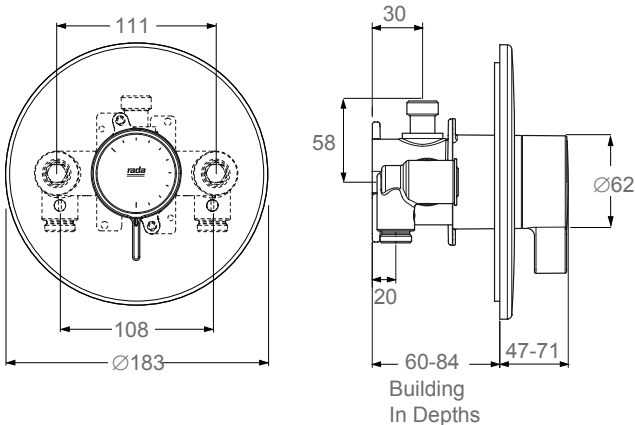

Exposed

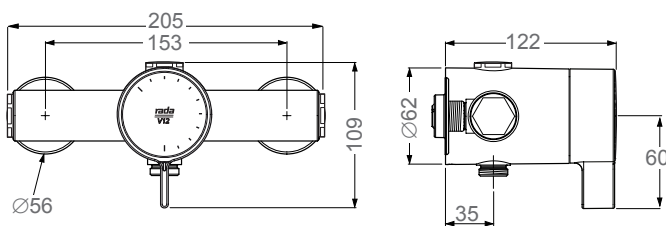

Specify as: Rada V12 Exposed Shower Valve (1.1651.001)

Surface mounted thermostatic shower valve certified to TMV3 performance and featuring Insutech® technology. Sequential single lever operation from cold through to warm. Includes service-free cartridge, check valves, filters and optional flow regulators.

Specify as: Rada V12 Concealed Shower Valve (1.1651.002)

Built-in thermostatic shower valve certified to TMV3 performance standard and featuring integral isolating ball valves. Sequential single lever operation from cold through to warm. Includes service-free cartridge, check valves, filters and optional flow regulators.

Flow Diagram

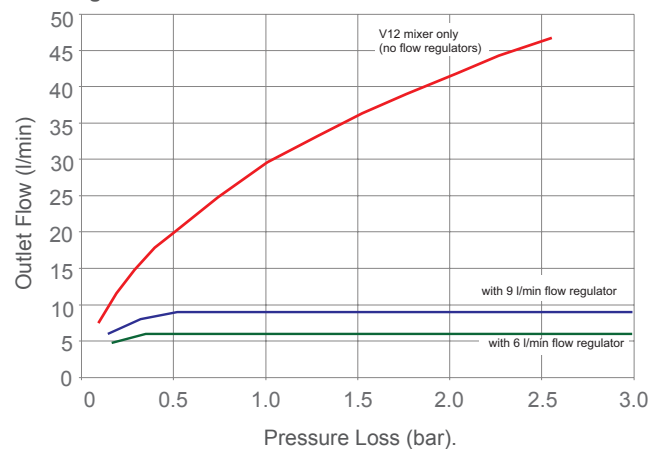

TECHNICAL SPECIFICATION

The Rada V12 mixers are a robust, easy to use range of thermostatic showers incorporating a proven thermostatic cartridge.

The Rada V12 exposed model incorporates Insutech® technology. This technology ensures that all outer surfaces are safe to touch. Optional diverters are available for use with these mixers. Refer to the Rada V12 Diverter datasheet (P6246).

Installation and Maintenance

Suitable for the majority of plumbing systems both low and high pressure.

Exposed Model:

Dual outlet body allows easy installation with top or bottom outlet. Large area inlet filters are accessible from the elbow with minimum disturbance.

Concealed Model:

This model can be built into a stud or solid wall, brackets provided. Servicing is made easy with isolators incorporated into the inlet elbows to allow access to the large area inlet filters or for replacement of the thermostatic cartridge.

For more detailed information on these mixers please refer to the Installation and User Guide.

Connections

Standard connections are: **hot - left, cold - right, top or bottom outlet.**

Exposed Model:

Suitable for rising, falling or rear entry supplies.
Inlets: 15 mm compression.
Outlet: 15 mm compression/½" BSP Flat Face.

Concealed Model:

Suitable for rising or falling supplies, top or bottom outlet.
Inlets/Outlet: 15 mm compression.

Approvals

Buildcert TMV3 Thermostatic Mixing Valve Scheme approved:
HP-S, HP-SE High Pressure Showering.
LP-S Low Pressure Showering.
WRAS listed (Water Regulations Advisory Scheme).
Designed, manufactured and supported in accordance with accredited BS EN ISO 9001:2008 Quality Management Systems and BS EN ISO 14001:2004 Environmental Management Systems.

Operation

The Rada V12 is operated via a single sequential control which when rotated initially opens the valve, then increases temperature from cold to a pre-set maximum.

Materials

Exposed model: Chrome Plated Polished Brass Body and Elbows;
Chrome Plated Zinc Die Cast Lever.
Concealed model: DZR Body and Elbows; Chrome Plated Zinc Cast Lever, Chrome Plated ABS Trim.

Temperature Control

Temperature range from cold to preset maximum.

The maximum temperature that can be selected is factory set at approximately 43°C, but this can be reset on site if required (by an authorised person).

Thermostatic control $\pm 1^\circ\text{C}$ within the range 35°C - 45°C (assuming supplies of 15°C cold, 65°C hot at nominally equal pressures).

Note! In the event of loss of either supply, the valve will automatically shut off.

Minimum temperature differential of blend to either supply 10°C.

Supply Conditions

Cold water temperature range 5°C to 25°C.

Hot water temperature range (recommended) 60°C - 65°C.

Maximum hot water temperature 85°C.

Note! For reasons of general safety, hot water storage temperatures should be maintained at between 60°C - 65°C where serving ablutionary applications. The mixing valve can accept temporary excursions above 85°C without damage, however operation at such elevated temperatures is not recommended.

Pressures

Dynamic Supply Pressure (Running):

Minimum: 0.1 Bar.

Maximum: 5 Bar.

Maximum Static: 10 Bar.

For optimum operation the inlet pressures should be nominally equal. Maximum Pressure loss Ratio*: should not exceed 10:1 in favour of either supply during flow.

** Pressure loss ratio is determined by subtracting the resistance to flow of the outlet pipework and outlet fittings (generally known as the 'back pressure', and measured at the outlet of the mixing valve) from the dynamic pressures of the hot and cold water at the inlets of the mixing valve. This is at its extreme when the mixing valve is being used at its lowest flow rate and when the maximum inequality occurs in the pressure of the hot and cold water supplies.*

Flow Rates

Refer to the flow performance graph.

Minimum flow rate: 3 l/min.

Maximum flow rate: 40 l/min.

At supply pressures > 0.5 bar, we recommend fitting the 9 l/min flow regulator or for increased water saving a 6 l/min flow regulator should be fitted (supplied).

Rada is a registered trademark of Kohler Mira Limited.

The company reserves the right to alter product specification without notice.

© January 2012 Kohler Mira Limited. All rights reserved.

No part of this document, or any accompanying document, may be reproduced or transmitted in any form or by any means, including photocopying or electronically, without the permission of Kohler Mira Limited.

A **KOHLER** COMPANY



FM 14648

