

RADA V10 THERMOSTATIC SHOWER VALVE



- Buildcert TMV2 Scheme Approved
- WRAS Approved
- Single sequential operation off-cold-warm
- Easy grip handle complete with durable, clear graphics
- Robust construction to withstand heavy usage in public areas
- Optional 6 l/min flow regulator for increased water savings. A 9 l/min flow regulator is also supplied



Specify as: Rada V10 Exposed Shower Valve (1.1651.004)
 Surface mounted, single sequential thermostatic shower valve. Supplied complete with integral strainers and optional flow regulators.

Specify as: Rada V10 Concealed Shower Valve (1.1651.005)
 Built-in, single sequential thermostatic shower valve. Supplied complete with integral strainers and optional flow regulators.

Specify as: Rada V10 Rigid Riser Accessory (1.1651.020)
 Designed to connect the Rada V10 Exposed Shower Valve to either the Rada VR145 or Rada VR2-ES Showerheads.

Dimensions (mm)

Concealed

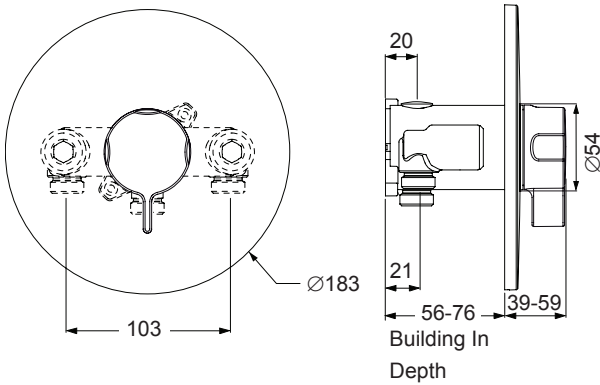

Exposed

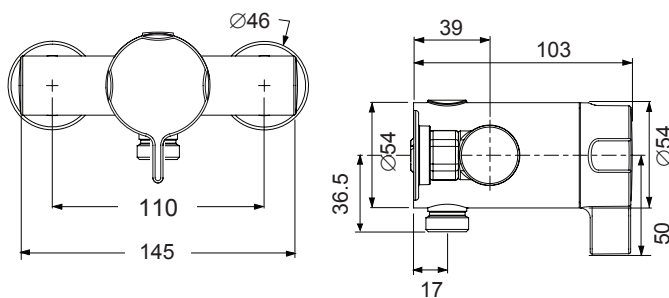

Flow Diagram

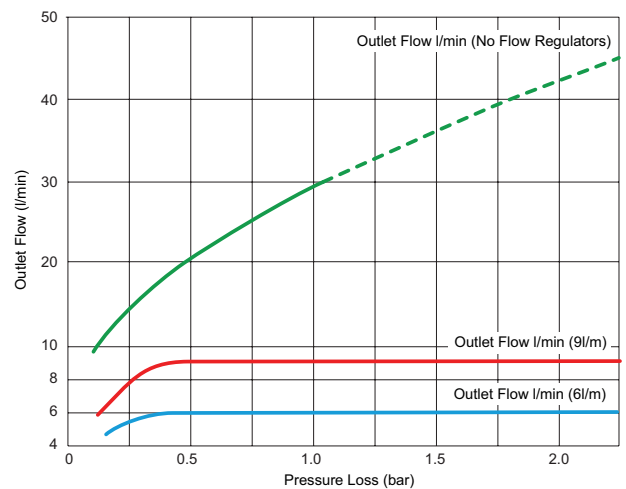

TECHNICAL SPECIFICATION

The Rada V10 mixer incorporates a proven thermostatic cartridge providing extended service-free reliability, protected by integral inlet filters.

Installation and Maintenance

Please refer to the appropriate Product Manual.

Connections

Inlets: 15 mm Compression.

Outlet: ½" BSP Flat Face / 15 mm Compression.

Standard connections are: **hot - left, cold - right, outlet - bottom or top.**

Approvals

Buildcert TMV2 Thermostatic Mixing Valve Scheme approved:

HP-S High Pressure Showering

LP-S Low Pressure Showering

WRAS listed (Water Regulations Advisory Scheme).

Designed, manufactured and supported in accordance with accredited

BS EN ISO 9001:2008 Quality Management Systems and

BS EN ISO 14001:2004 Environmental Management Systems.

Operation

The Rada V10 is operated via a single sequential control which when rotated initially opens the valve, then increases temperature from cold to a pre-set maximum.

Materials

Body: Chrome Plated DZR Brass.

Lever: Chrome Plated Zinc Die Casting.

Temperature Control

Temperature range from cold to preset maximum.

The maximum temperature that can be selected is factory set at approximately 41°C, but this can be reset on site if required (by an authorised person).

Thermostatic control $\pm 1^\circ\text{C}$ within the range 35°C - 45°C (assuming supplies of 15°C cold, 65°C hot at nominally equal pressures).

Note! In the event of loss of either supply, the valve will automatically shut off.

Minimum temperature differential of blend to either supply 12°C.

Temperature Range

Cold water temperature range 5°C to 20°C.

Hot water temperature range (recommended) 55°C - 65°C.

Maximum hot water temperature 85°C.

Note! For reasons of general safety, hot water storage temperatures should be maintained at between 60°C - 65°C where serving ablutionary applications. The mixing valve can accept temporary excursions above 85°C without damage, however operation at such elevated temperatures is not recommended.

Pressures

Dynamic Supply Pressure (Running):

Minimum 0.15 Bar.

Maximum 5 Bar.

Maximum Static 10 Bar.

For optimum operation the inlet pressures should be nominally equal.

Maximum Pressure Ratio*: should not exceed 10:1 in favour of either supply during flow.

* *Pressure loss ratio is determined by subtracting the resistance to flow of the outlet pipework and outlet fittings (generally known as the 'back pressure', and measured at the outlet of the mixing valve) from the dynamic pressures of the hot and cold water at the inlets of the mixing valve. This is at its extreme when the mixing valve is being used at its lowest flow rate and when the maximum inequality occurs in the pressure of the hot and cold water supplies.*

Flow Rates

Refer to the flow performance graph.

Minimum flow rate: 3 l/min (at nominally equal pressures).

Maximum flow rate: 30 l/min (achieved at 1 bar pressure loss across the valve with flow regulators removed).

At supply pressures > 0.5 bar, we recommend fitting the 9 l/min flow regulator. For increased water saving the 6 l/min flow regulator should be fitted (both supplied).

Rada is a registered trademark of Kohler Mira Limited.

The company reserves the right to alter product specification without notice.

© January 2012 Kohler Mira Limited. All rights reserved.

No part of this document, or any accompanying document, may be reproduced or transmitted in any form or by any means, including photocopying or electronically, without the permission of Kohler Mira Limited.

A **KOHLER** COMPANY



FM 14648

