

ASSEMBLY INSTRUCTIONS

Sapphire Meeting Table

Size: 1200 x 1200 mm

www.jasonl.com.au

Need help!

Call us on
1300 527 665

jason.l
your office furniture mate

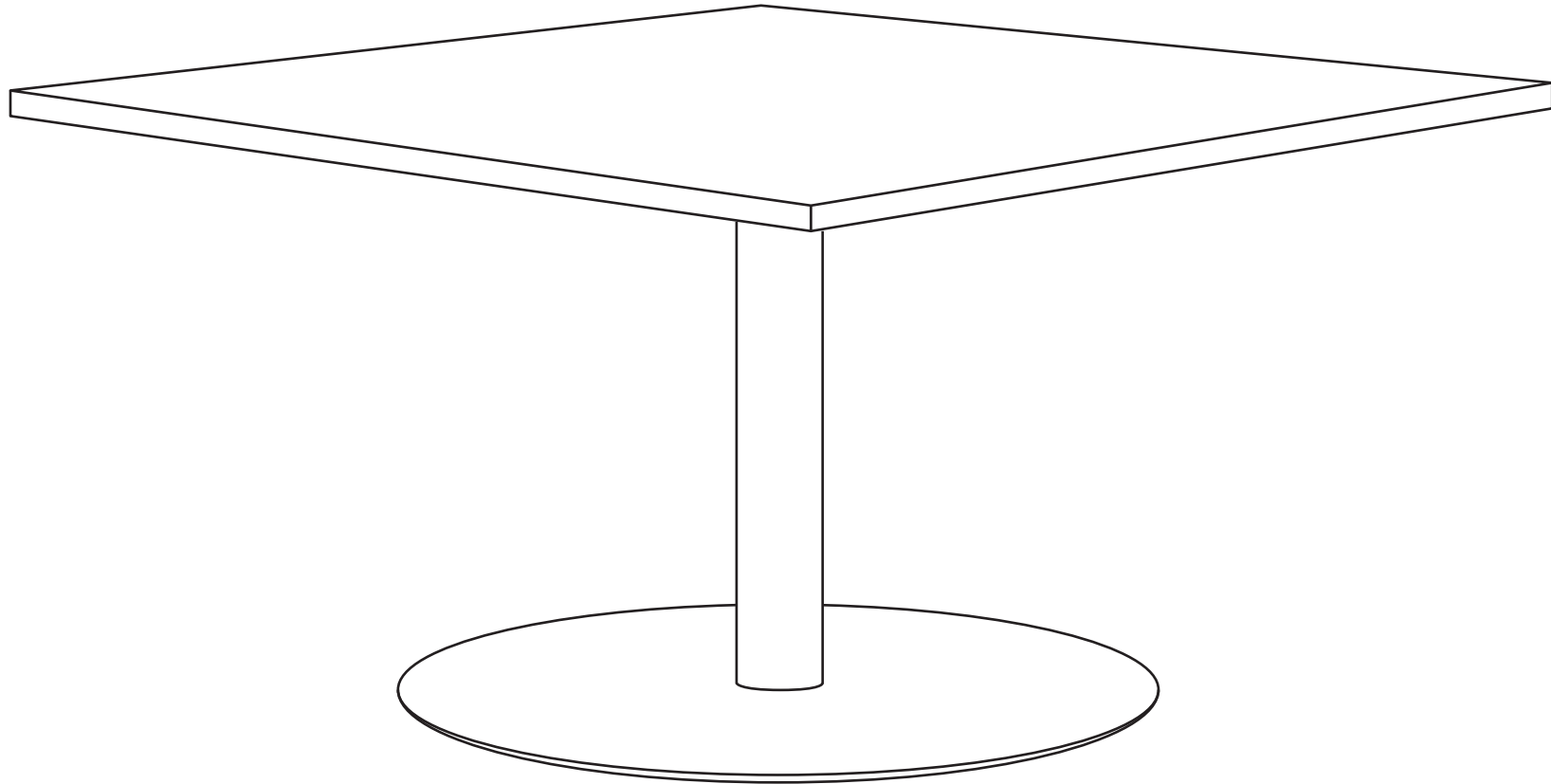

Tools Required: Power screwdriver. We strongly recommend using an impact drill gun together with thread locking all screws.

Note: Please ignore any pre-drilled holes or nut inserts that maybe present in your top(s). They will not match your particular table/desk base and woods screws will be required to be screwed directly into the underside of the top.

Note: It is important to fully tighten all bolts and screws before attaching the top(s) so that the frame is sufficiently rigid. Failure to do this may affect stability once the tops are attached.

ASSEMBLY INSTRUCTIONS

Sapphire Meeting Table

Size: 1200 x 1200 mm







www.jasonl.com.au

Need help!

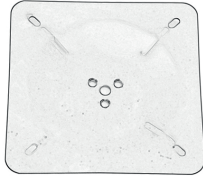
Call us on
1300 527 665

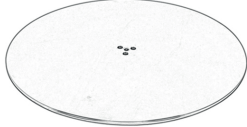
jason.l
your office furniture mate

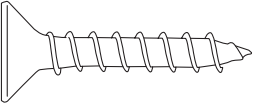

A * 1 	B * 1 
C * 1 	D * 3 (M8*30mm) 
E * 3 (M8*30mm) 	F * 1 
G * 8 woodscrews 	

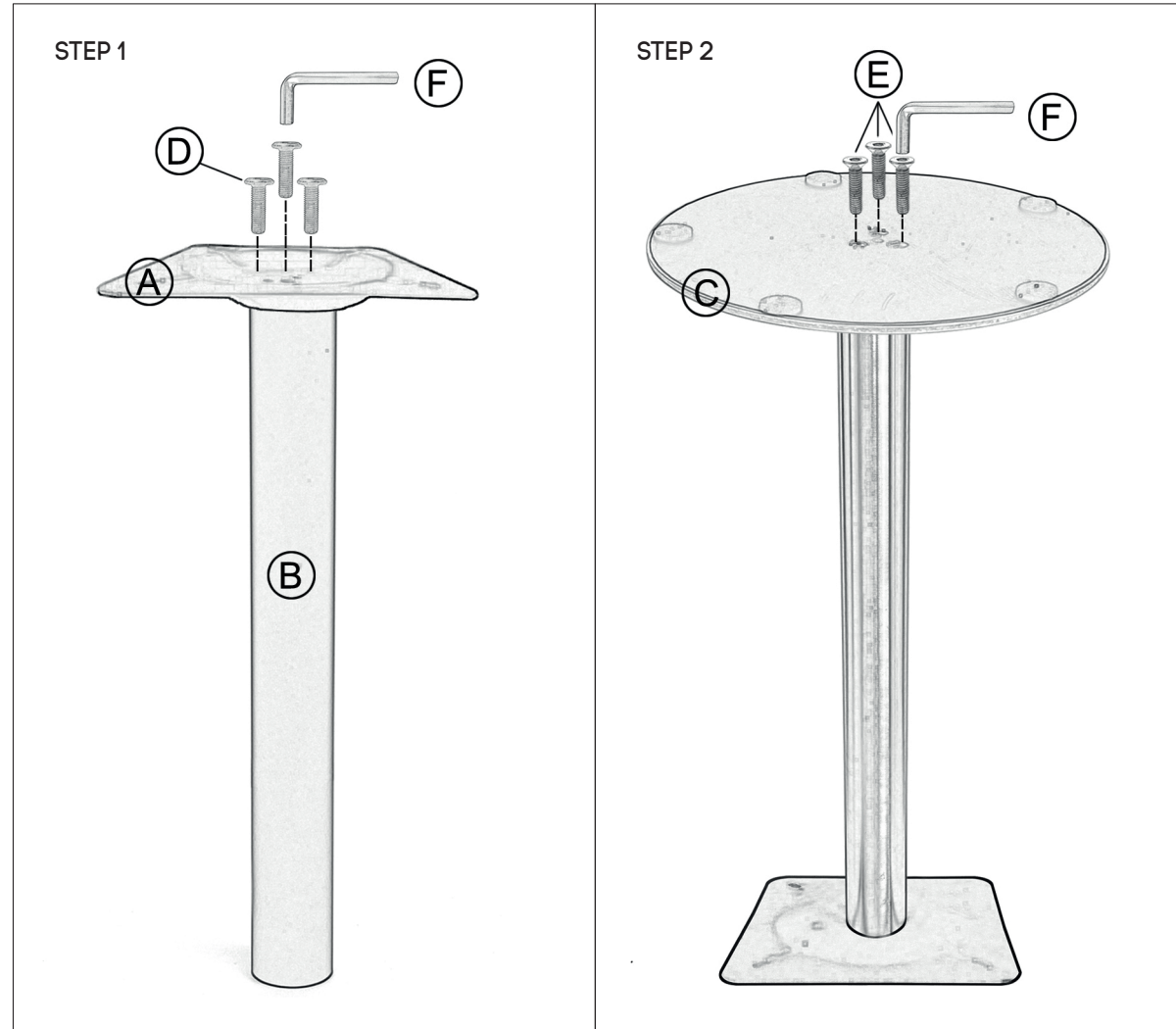

ASSEMBLY INSTRUCTIONS

Sapphire Meeting Table

Size: 1200 x 1200 mm

www.jasonl.com.au

Need help!

Call us on
1300 527 665

jason.l
your office furniture mate



STEP 3

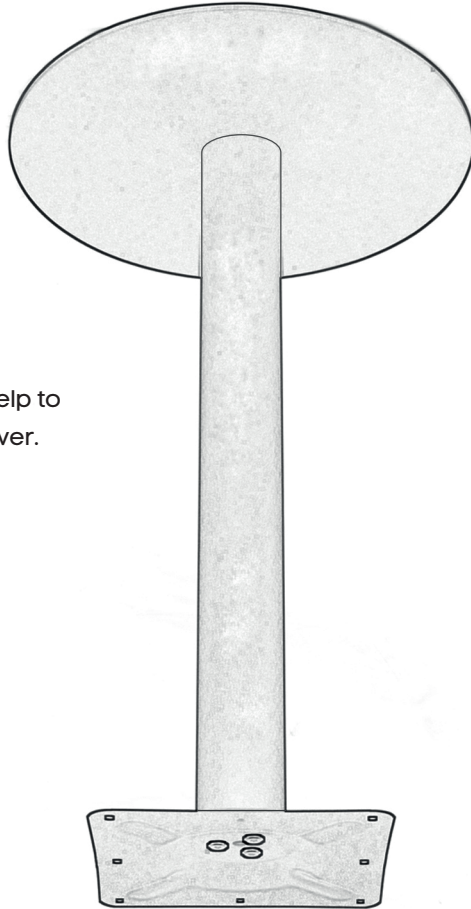

Ask a second person to help to turn the table and base over.

Careful: tables are heavy.

STEP 4

Adding the Top

Screw the table top through the square top plate using woodscrews (G*8 wood screws) through the following holes.

