

Liftow



TOYOTA | 3-9



USED EQUIPMENT | 12



RENTALS | 13



PARTS | 14



SERVICE | 15



TRAINING | 23-25



"Our growth will have a significant impact on Liftow's presence in the forklift market. We plan on taking advantage of the respective strengths that exist to create overall improvement."

- Roger Sutton, President & CEO

2018 continued to be another year of growth for Liftow. After many years, our Head office/Toronto branch and our Brampton branch, now located in Vaughan, moved into new and larger homes to accommodate our growth. It was a challenging move, but with the efforts of the whole team it was a great success.

Also, Liftow's Instructional Services department, which has been providing material handling training to our customers for over 20 years, joined forces with LIFT Training. As a result, LIFT Training, previously a division of Lift Temp, is now a significant member of the Liftow Group of Companies. This partnership will reinforce our team and strengthen our commitment to provide exemplary training to our customers. As a result of this merger, several new exciting online and blended safety training programs will now be offered.

When Liftow first started in 1960, there were only a few working together as one team to best serve our customers. Over the years we have attempted to retain this entrepreneurial spirit by providing a consistent local quality of service through multiple branches and small local teams.

Our team, now in the neighbourhood of 700, operating out of 22 branches, remains committed to this original endeavour!

There's a reason we're #1

- Over 58 years servicing the material handling industry and supporting customers like you!
- We sell the #1 selling lift truck in the world – TOYOTA INDUSTRIAL EQUIPMENT
- Quality Used Toyota lift trucks – originally owned and maintained by Liftow
- Lift truck rentals – online rental request
- 24/7 service – ensures you peace of mind to keep you productive and profitable
- Toyota Quality OEM and aftermarket parts – online parts request
- Industry leaders in industrial safety training – wide range of training programs offered
- Comprehensive safety product catalogue – purchase online and shipped direct
- Racking system solutions
- All sales personnel carry mobile phones – fully accessible with voice mail and texting options, keeping you connected!
- Great service and quality at a fair market price
- We strive to meet and exceed the expectations of those we serve
- Full online access to all of our product offerings – www.liftow.com



Liftow Limited

The #1 Toyota forklift dealer in North America.

Stay connected with Liftow through our social media!

Learn more about Liftow behind the scenes and keep up with the latest industry news and special offers.





Why choose Toyota?

As the manufacturer of the #1 selling lift truck in the world, Toyota has built a reputation of excellence on quality, reliability and durability. We offer a full line of high quality lift trucks that are designed to increase productivity and safety with a commitment to environment responsibility.

Toyota has been honoured numerous times for its dedication to continuous improvement and its commitment to safety and the environment. Whether it be Toyota's industry leading technology of the SAS (System of Active Stability) system, or Toyota's commitment to reducing its carbon footprint by reducing emissions on LPG, gasoline or CNG lift trucks by 70% of current standards or supporting a zero-landfill manufacturing facility, Toyota is a true leader in the material handling industry.

Here are some of Toyota's achievements:

- Ranked #1 for lowest cost of ownership (Independent study by Peerless Media Research Group)
- #1 in Quality and Value (Modern Materials Handling magazine)
- #1 Safest Lift Truck (Independent study by Peerless Media Research Group)
- #1 for Fewest Safety Related Incidents (Independent study by Peerless Media Research Group)
- Top 25 Green Supply Chain Partners (Inbound Logistics)
- Toyota is the first and only manufacturer to offer UL-listed, EPA and CARB certified Compressed Natural Gas (CNG) powered lift trucks
- SAS leading technology



TOYOTA 8FBEU

3-Wheel Electric Lift Truck



8FBEU 3-Wheel Lift Truck
• 3,000 - 4,000 lbs. capacity

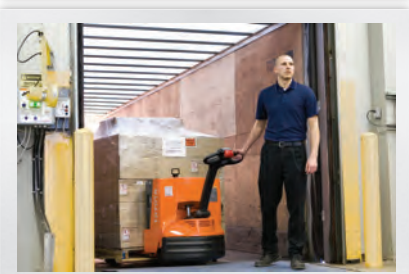
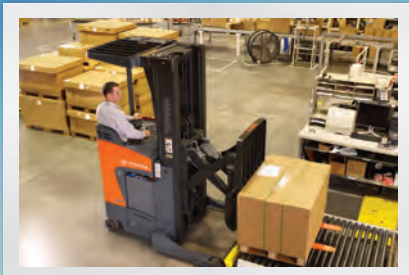
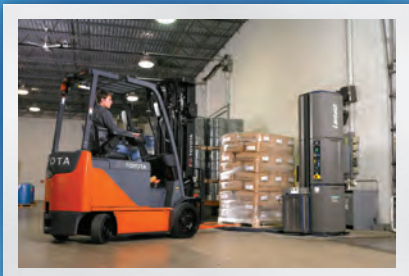

9BRU Single & Double Reach Truck
• 3,000 - 4,500 lbs. capacity



8HBW23 Walkie Pallet Truck
• 4,500 lbs. capacity

Toyota's Electric Lineup

Programmable drive systems and step-less acceleration make precision control a key advantage of Toyota lift trucks. Advanced transistors and heavy-gauge steel construction extend longevity.



8FBCU 4-Wheel Lift Truck
• 4,000 - 6,500 lbs. capacity



8BNCU Stand-Up Rider Truck
• 3,000 - 4,000 lbs. capacity



80V Core Electric Forklift
• 4,000 - 11,000 lbs. capacity



8BW Walkie Straddle Stacker
• 2,000 - 2,500 lbs. capacity



7BPUE15 Order Picker Truck
• 3,000 lbs. capacity



8HBW Electric Pallet Truck
• 6,000 and 8,000 lbs. capacity



8HBE End-Control Walkie/Rider
• 6,000 and 8,000 lbs. capacity



8HBC Center-Control Rider
• 6,000 and 8,000 lbs. capacity



8TB50 Tow Tractor
• 10,000 lbs. tow capacity

For more information, visit: www.liftow.com/toyota



Toyota Internal Combustion

Warehouse, distribution, manufacturing,



Cushion Tire Indoor Trucks



8FGCU Series

• 3,000 - 6,500 lbs. capacity



8FGCU-BCS Boxcar Special

• 8,000 - 12,000 lbs. capacity



8FGCU Large Capacity

• 8,000 - 15,500 lbs. capacity



Leading the industry in safety technology, no other lift truck offers a system comparable to Toyota's System of Active Stability.

Toyota's SAS electronically monitors and controls the lift truck's operations through patented technology to help reduce the risk of tip-overs.

SAS is composed of three systems:

Active Control Rear Stabilizer:

When instability is detected, SAS instantly locks a hydraulic cylinder on the rear axle, changing the truck's stability footprint from triangular in shape to rectangular. This increases stability and reduces the likelihood of a lateral turnover.



Active Mast Function Controller:

Forward Tilt Angle Control limits forward tilt and Rear Tilt Speed Control governs rear tilt speed; both features decrease the risk of spilling a load and reduce the chances of forward or rearward tip-over.

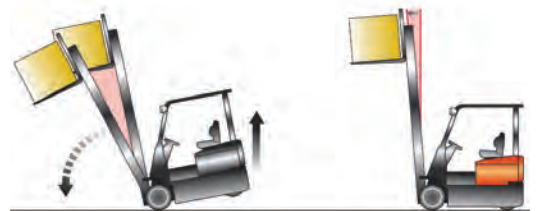

Automatic Fork Levelling:

Positions the forks horizontally to the floor with the push of a button on the tilt lever, allowing safer and easier load handling.

Engine Lift Trucks

lumber and brickyard.



Pneumatic Tire Outdoor Trucks



8FGU/8FDU Series
• 3,000 - 6,500 lbs. capacity



8FGU/8FDU Series
• 8,000 - 11,000 lbs. capacity



8FGU/8FDU Large Capacity
• 13,500 - 17,500 lbs. capacity



THD Series - Heavy Duty
• 15,000 to 250,000 lbs. capacity

Plug it in or fuel it up?

It's a question that all lift truck buyers face when choosing between an electric lift truck or internal combustion engine truck. It's true that each one performs the same function (moving or lifting materials) but remember, the way each lift truck does this and what they are capable of doing depends upon the power source.

Contact your local Liftow Forklift Specialist to help answer any questions you may have!



For more information, visit: www.liftow.com/toyota





Our new Toyota 8HBW23 - 4,500 lb. load capacity electric pallet truck

Highly maneuverable, compact rugged design that is ideal for confined and congested applications.

- 4,500 lb. capacity
- 24 volt 
- AC drive motor
- Smart lift/lower system
- Electric brake release
- 'No tools required' cover
- 'Click-to-Creep' feature
- Swing-out or maintenance-free battery
- Cold storage to -20° (optional)

Discuss financing options with your local sales representative.



WHAT IS T-MATICS?

T-Matics is a fleet management tool that utilizes a Vehicle Management System (VMS) to track and report operating behavior of a forklift and/or a forklift operator.

WHAT IS A VMS?

A VMS is a system that facilitates the transfer of operating data from a forklift to individuals via standard or customized reports.

WHAT MAKES TOYOTA T-MATICS DIFFERENT?

T-Matics MOBILE is the only individual forklift-based cellular telematics solution currently on the market with a full-featured set of monitoring and analytic capabilities. T-Matics MOBILE is capable of generating reports on individual forklifts or entire fleets. T-Matics COMMAND is powered by I.D. Systems, Inc. which, for more than 15 years, has successfully deployed wireless asset management technology to the world's leading manufacturers, distributors, retailers, airlines, and government agencies.

PRODUCT FEATURES	T-MATICS MOBILE	T-MATICS COMMAND
Hour Meter/Utilization	•	•
Impact Alerts	•	•
Error Code Alerts	•	•
GPS Tracking	•	
Cellular Transmission	Truck-Based	Facility-Based
Wi-Fi Transmission		•
OSHA Checklist		•
Operator Access Control		•
Web-Based Reporting	•	•
User Display		•
Factory & Field Installation	•	•

TOYOTA 80V

TOYOTA 80 Volt Indoor/Outdoor Electric Pneumatic Forklift

- 4,000-11,000 lb. lifting capacity
- Tough enough for construction sites - brick, block and pipe, concrete, oil and gas

▶ **SYSTEM OF ACTIVE STABILITY**

acts automatically in uncertain situations to protect operator, and reduce product and forklift damage

▶ **EXCELLENT OVERHEAD GUARD**

VISIBILITY even with optional cab; wide-view mast options available

▶ **SUPERIOR OPERATOR COMFORT**

thanks to large entry/exit with six cab options

▶ **TWICE THE RUN TIME** of 36V or 48V competitors

▶ **EXTREME VERSATILITY**

for a broad spectrum of applications, with capacity and power of IC plus clean emissions of an electric

▶ **MULTIPLE MAST OPTIONS**

available to suit your application

▶ **WIDE RANGE OF OPTIONS**

gives you more than 65 options and countless configurations to build the perfect forklift for your application

▶ **EXTRA DURABLE**

IC-strength, tough truck body with no plastic parts

▶ **EASILY PROGRAMMABLE**

to fit user preferences and aid serviceability

▶ **LIFT/LOWER SPEED CONTROL**

automatically slows mast as it comes into free lift and dramatically slows forks near ground to reduce damage and wear





Toyota's large capacity forklifts. Big jobs. Big trucks. Big results.



THDE Sit Down Electric
30,000 - 80,000 lb. lifting capacity



THDC Sit Down Cushion
18,000 - 110,000 lb. lifting capacity



THD Sit Down Pneumatic
15,000 to 250,000 lb. lifting capacity



THD Sit Down Container Handlers
80,000 to 90,000 lb. lifting capacity



Toyota quality, reliability and safety... certified!

Components we inspect and repair:

- Mast assembly
- Powertrain
- Hydraulic system
- Steering column and steer axle
- Brakes and tires
- Overall physical condition

Why choose Liftow Certified Used Forklifts?

- All-inclusive lifting device inspection and emissions certification*
- Complete inspection and repair program on reconditioned units
- All work completed by Toyota factory trained technicians
- Industry leading comprehensive warranties
- Financing and leasing options available
- 18 full service locations
- Genuine Toyota parts

* where applicable by law



How to select a good used lift truck:

Liftow

- Dealer's reputation
- Check its mechanical condition
- Check for safety requirements
- Check the serial number
- Check references



Most units have been maintained by Liftow their entire service life.

Check out our used truck inventory!



Visit us online! www.liftow.com/used





Need to rent a forklift?



- Increase productivity and reduce downtime
- 1,500+ unit rental fleet includes:
 - forklifts for all applications
 - Toyota's industry leading technology and safety features
 - fully certified and dealer maintained forklifts
 - current models
- Special requests available (i.e. heated cabs, quad masts, attachments etc.)
- Quick delivery - right to your doorstep!
- Competitive rental rates



Speak to our representatives about finding the right truck and rental plan for your application.

Go online to request a rental quote!
www.liftow.com/rentals





Purchase Original Toyota Parts for your Toyota Forklift to Maintain Ultimate Performance!

Why choose Liftow's Parts Department?

- We are the largest Toyota forklift dealer in North America
- Experienced and qualified parts staff
- Quick and accurate parts identification via electronics parts catalogue
- Overnight emergency air orders upon request
- Toyota orders processed at two order points daily
- Parts and attachments available for all major brands of forklifts and other material handling equipment
- Wide range of allied products such as dock boards, rolling ladders, pallet trucks and four-wheel carts
- Mobile tire service - supply and install tires at customer location
- ***Parts for ALL makes and models!***



Order your forklift parts online! www.liftow.com/parts





2017 Toyota Master Technician Platinum Winner,
Richard Ghisyawan of our Toronto branch.

Who Better to Service Your Toyota Equipment Than Your Local Toyota Dealer!

- Toyota Factory Trained & Certified Technicians
- **200+** Technicians on staff
- **150+** Fleet of Service Vans, Fully Stock with Parts
- **16** Local Service Branches across Ontario, Quebec and Atlantic Canada
- 24 Hour Emergency Service
- Repairs to All Makes and Models



PROGRAMMED MAINTENANCE AND INSPECTIONS

Reduce downtime and increase productivity by utilizing one of our Programmed Maintenance plans. Regular professional dealer supplied maintenance will enhance your equipment's reliability, reduce your overall cost of ownership and maximize its residual value.

- Lifting Device Inspections and Certifications
- Emissions Testing
- Fixed Rate Maintenance plans (customer owned, leased or rented trucks)
- On-site service and major shop facilities available
- Battery/Charger maintenance and repairs
- Customized maintenance plans based on customer's unique needs and environment
- The only Toyota Factory authorized warranty provider in the area
- Authorized warranty provider for most forklift attachment manufacturers

Visit us online! www.liftow.com/service



For 30 years Liftow has been servicing batteries for our customers in Ontario.

Today's battery powered forklifts run faster, harder and hotter. Battery manufacturers mandate that warranty coverage is dependent on proof of quarterly PM's and interface module downloads for opportunity and fast charge applications. Regular inspections of watering system components, analysis of charging compliance and cleaning of battery surfaces are imperative to long term trouble free battery and charger life.

- Factory trained and ESA certified battery technicians
- Fleet Watering
- Programmed Maintenance
- Cable/Cell Replacement,
- Acid Balancing
- Battery Rebuilding

Liftow provides our customers with another one stop service offering!



Your perfect warehouse is one with the functionality to meet your current needs and the adaptability to accommodate your future needs.

Let Liftow help you design it! Here are some things to consider:

📍 LOCATION - This is your first big decision. And here's the key consideration in making it: What's the objective of your warehouse? It might be to facilitate the shortest leadtimes possible. To improve your current logistics. Or another objective altogether. Whatever your objective, it should inform your decision.

📏 SPACE PLANNING - Measure first. Build to fit!

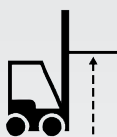

▶ Ceiling Height

The clear ceiling height determines how high

your materials can be lifted. This measurement should take into account the lowest ceiling-mounted components - sprinklers, lighting, HVAC system, etc. Forklifts should also be reviewed for lifting height to ensure they can safely reach the highest racking when loading or unloading materials. Many localities regulate ceiling and racking height. Check local regulations before proceeding.



▶ Aisle Width

Determine aisle width based on the type of

forklifts you plan to use in your warehouse. A forklift should pass easily through the aisle without making contact with racking or stored materials. Aisle dimensions are measured load to load to accommodate pallet overhang, but should also consider the forklift's right angle stacking position. A 10' rack-to-rack space may really be 9.5' when measured load-to-load. Overhang is approximately 3" for each side of the pallet.

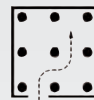

▶ Column Spacing

Structural columns in your warehouse - if you have

them - will dictate your racking design and aisle widths. In some instances, storage is lost if pallet positions are blocked by columns. Designing around columns and the flow of materials requires you to reconsider your warehouse layout, even if the setup has been in place for years. Flipping the racking (e.g., vertical to horizontal) can hide columns within the racking, exposing more of the warehouse floor. If you use electric forklifts, you'll need to factor in where to house chargers. They're commonly found within racking, along a wall or in a separate battery charger room.

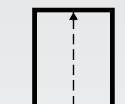

▶ Easy Access

Don't overlook building details that require easy

access. This includes electrical panels and water shut-off valves. Lowest-door height is also a major consideration. To ensure your building is up to code, work with a local contractor to review regulations.



Toyota Commercial Finance is a leading provider of financial services offering an extensive line of financing plans with competitive terms to Canadian Toyota customers through participating Toyota Dealers. Since 2003 we have offered simple, proactive financing solutions to make it easy for customers to acquire Toyota industrial Equipment and easy for Dealers to market the products. Through our North American Dealer network we develop programs that let our customers focus on operations rather than financing. Our offerings include:

- Trac lease
- Long term rental and operating lease
- Master lease
- Credit lines
- Full service maintenance
- Flex term or seasonal lease

As part of the Toyota family of companies, Toyota Commercial Finance offers our customers a clear advantage in understanding the asset they are using to grow and sustain their business and in understanding the need for flexibility throughout the customer's business lifecycle. We do this by providing fast, efficient and competitive financing to obtain the material handling equipment they need.



Toyota Commercial Finance Canada
401 The West Mall, Suite 630
Toronto, ON M9C 5J5

Tel: (416) 621-5522 or 1-800-530-0225
www.toyotacf.ca



Save time, money and increase productivity



Carton Clamp

Designed for the warehousing, beverage, appliance and electronics industries. Carton clamps allow palletless handling.



Paper Roll Clamp

Cascade offers a full line of paper roll clamps and roll clamp damage reduction options to handle paper rolls regardless of diameter, weight or type of paper.



Push/Pull

Allow you to ship, receive and warehouse unit loads on inexpensive slip sheets rather than pallets.



Bale Clamp

Palletless handling of nearly any type of baled product such as cotton, wool, synthetic textiles bales, corrugated boards or newsprint.



Fork Positioner

The ability to position the forks from the driver's seat, rather than getting off the truck, saves time and reduces product and pallet damage.

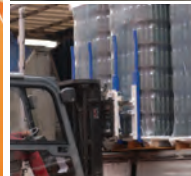

Single-Double Pallet handler

Designed for the bottling, brewing, production or warehouse/shipping industries. You can handle a single pallet, or spread the forks hydraulically to lift, carry and sideload multiple pallets side by side.



Layer Picker

Beverage warehouses and distribution facilities can benefit from the speed and versatility the Layer Picker offers. Replace costly manual labor with the versatile Cascade Layer Picker.



Rotator

Rotators add 360° revolving motion, in both directions, to truck forks. Used in food processing and manufacturing for inverting and dumping loads.

Contact a Liftow material handling specialist today for more info!

Connecting your power.

At East Penn Canada, we provide you with high quality DEKA batteries, energy efficient chargers and easy to use watering accessories, connecting you to a complete power solution for all of your material handling needs.



eastpenncanada.com

POWER OF INNOVATION



Oldham Batteries Canada Inc. brings a world of power to the market. We have a passion for innovation and technology designed to meet our customers' specific needs.

Oldham offers the complete line of HAWKER® power solution products — from their newest FLEX™ batteries featuring Thin Plate Pure Lead battery technology to their extensive group of modular high-frequency switch-mode smart chargers.

To learn more, call 1-800-361-2048 or send an email to info@oldham.ca.

The cloud-based HAWKERNET™ battery management tool provides remote access to custom-developed data on your fleet's batteries.



Oldham Batteries Canada Inc. • www.oldham.ca • 800.361.2048 • info@oldham.ca
HAWKER® • www.hawkerpowersource.com



INDUSTRIAL STRENGTH
FOR ALL YOUR INDUSTRIAL NEEDS



POWERING THE WORLD **FORWARD**

gnb.com

The World of Power Solutions.

Crown Battery's Complete Line of SLI & Industrial Batteries

Only the Best, All the Time, Since 1926.

High quality. World class. A battery to fit practically every application.
This is an excellent time to start something...with Crown Battery.

- Starting
- Motive Power
- Commercial
- Mining
- Deep Cycle
- Railroad



The Power Behind Performance



Crown Battery of Canada Limited
7430 Pacific Circle
Mississauga, Ontario
L5T2A3
905-564-1050

CROWN BATTERY OF CANADA LIMITED | MADE IN USA | www.crownbattery.com

These machines are engineered to be durable and easy to use. They are loaded with features to tackle your unique tasks and keep your people and equipment working harder, longer. Their thoughtful engineering and versatility make these scissor lifts dependable solutions for access challenges in your facilities.

AC DRIVE MOTOR

- ▶ **ZERO DEGREE INSIDE TURNING RADIUS**
Tight turning makes operating the scissor lift intuitive and easy.
- ▶ **PLATFORM EXTENSION**
Additional platform length allows operators to reach across fixed objects for greater accessibility and flexibility in completion of work.
- ▶ **TILT ALARM**
Alarm alerts operators to unsafe working conditions and limits platform movement until proper operation is restored.

ANTI-ROLLBACK FUNCTION

- ▶ **FOLD-DOWN GUARDRAILS**
Folding guardrails allow larger scissor lifts to pass through doorways and other low obstacles. Easy to use function utilizes snap-lock polls for simple manipulation by operators. (Option on SV1930E model)
- ▶ **DUAL OPERATIONAL MODES**
Available on the SV2632 and SV3246 models, high capacity mode provides increased platform capacity at lower heights for flexible use of the scissor lift in multiple work settings.
- ▶ **UPPER CONTROL BOX**
Upper platform control box offers two mounting positions or remote use when operator is off of the scissor lift. Horn, battery discharge, tilt alarm indicators ensure easy operator use.

UNIQUE SOLUTIONS FOR UNIQUE CHALLENGES.

With five models offering working height from 25 feet up to 38 feet.

UP TO **38 FT.**
WORKING HEIGHT



EXTENDS UP TO 19 FEET



EXTENDS UP TO 26 FEET



EXTENDS UP TO 32 FEET



A DIVISION OF LIFTOW



Welcome to the new era of forklift training

LIFT Training is reinventing the forklift training industry. By making it more accountable, accessible, effective and efficient. By refusing to compromise on quality for the sake of convenience. And by introducing a consistent standard of excellence that guarantees all operators receive the training they need to ensure a safe workplace.

We understand how important it is to do this job right. Anything less could risk the health and safety of operators and employees all over Canada and the world.

That's why we don't take shortcuts and we don't cut corners. If it takes longer or requires more effort to do the right thing, then that's what we do. We climb the walls others go around.

It takes a lot of work, unrelenting passion and bull-headed determination to change an industry. We have that. That's why we are the knowledge leaders, technological pioneers, and recognized authorities throughout the business. And that's why we are, and will remain, so many miles ahead of everyone in the business.



A DIVISION OF LIFTOW

LIFTTRAINING.COM

ONLINE COURSES

WHAT'S INCLUDED

- Access your courses anytime, anywhere, with a computer, tablet or smartphone
- Videos, quizzes and interactive content designed for a proven learning experience
- Unlimited access. Take your courses at your time and pace



Forklift Theory

Get certified in just a few hours on all types of forklifts with our easy to use Forklift Theory program. Then you can complete the practical evaluation at your workplace or one of our training centres. Get certified on Counterbalance, Narrow Aisle Reach, Order pickers and Walkie-Rider pallet trucks.



WHMIS 2015

This course introduces you to Canada's Workplace Hazardous Materials Information System, or WHMIS. WHMIS was created in 1988 to help protect workers by educating them about the hazardous materials they may use in their workplace. This program covers the WHMIS program from its beginning in 1988 to its most recent version – WHMIS 2015.

eVALUATOR Program

eVALUATOR is an entirely **NEW** approach to in house forklift and safety training. It ensures the highest quality training delivered with absolute consistency every time. This innovative new online program is professional, comprehensive and teaches anyone to become an effective evaluator in less than a day.

Find out how we can make anyone at your company a certified eVALUATOR in just one day.



Fall Protection

This fall protection / fall arrest program will provide your employees with the knowledge and training they need to safely work at heights in an industrial environment.



Other Courses

- Supervisor Safety Awareness
- Pedestrian Safety Awareness
- Supervisor & Pedestrian
- Transportation of Dangerous Goods

GET STARTED TODAY AT
LIFTTRAINING.COM/ONLINE-TRAINING

BLENDED & INSTRUCTOR LED TRAINING

GET STARTED AT LIFTTRAINING.COM

FORKLIFT (Counterbalance, Reach Truck, Order Picker and Walkie Pallet)

NEW OPERATOR TRAINING: 2-DAY - 7-DAY

IN-CLASS

AT YOUR FACILITY

ONLINE

This is a fully comprehensive course designed for an individual with little or no lift truck experience. This course is comprised of intensive classroom instruction, including discussion and a written test, as well as hands-on practical training and evaluation. Upon successful completion of the course, the operator will be presented with a lift truck certificate as proof of training.



eVALUATOR - A revolutionary new approach to in house training!

ONLINE

Our eVALUATOR program offers everything your Train the Trainer program should, but doesn't. It's an entirely new level of forklift training, ensuring the highest quality delivered in a consistent, innovative new way. This professional, comprehensive online course can be taken at home or workplace, on mobile phones, tablets or computers, providing increased safety and ultimate convenience.

TRAIN-THE-TRAINER FORKLIFT: 3-DAY

IN-CLASS

AT YOUR FACILITY

This three-day course is geared towards your company's dedicated trainer or an experienced presenter who has had exposure to the equipment. It is designed to provide your company with trainers who will have both factual knowledge as well as the ability to present the material to your operators. There is an explanation of mandatory training topics, liability, documentation, evaluation and practical hands on training, to ensure that the trainers understand relevant evaluation points. This class includes a reference manual, a workbook for trainers, sample documentation forms, and a certificate. This course can either be held on-site at your location, or at one of our Liftow Lift Truck Training Centres.

** Includes a USB with PowerPoint presentation covering a wide range of required course elements. Operator Pre-requisite required*

OPERATOR REFRESHER

IN-CLASS

AT YOUR FACILITY

ONLINE

This course is designed for the operator who has previous certification, but requires updated training and legislation. Ministry guidelines and safe driving practices will be covered, and the program will be specifically geared to your application and equipment. This course will provide the attendee with a Lift Truck Certificate upon successful completion of the theoretical component.

CRANE (Bridge, Gantry, Semi-Gantry, Jib and Monorail)

RIGGING AND HOISTING TRAINING

IN-CLASS

A course to train operators on the principles of rigging and hoisting. Some of the topics included are:

- Occupational Health & Safety Act
- Inspection of Hoists and Slings
- Basic Principles of Hoisting
- Hitches and Sling Angles
- Lifting Hardware & Attachments
- Hoisting Safety
- Hand Signals



OVERHEAD CRANE TRAINING

IN-CLASS

A program designed specifically for the novice crane operator. Topics covered include:

- CSA B167-16
- Occupational Health & Safety Act
- Inspection of Cranes and Slings
- Basic Principles
- Hitches and Sling Angles
- Lifting Hardware & Attachments
- Crane Safety
- Hand Signals
- Turning Loads
- Crane Operation on Actual Site

CRANE TRAIN-THE-TRAINER: 3-DAY OVERHEAD CRANE AND RIGGING COURSE IS ALSO AVAILABLE.

AERIAL WORK PLATFORM (Scissor Lift, Boom and Portable Lift)

AERIAL WORK PLATFORM

IN-CLASS

This well-balanced program is ideal for the operator who has no experience but would like to learn to operate an aerial work platform.

AT YOUR FACILITY

ONLINE (COMING SOON)

FALL ARREST TRAINING

- Emergency evacuation procedures
- Fall protection legislation
- Employer, supervisor, worker responsibility
- Regulations for fall protection
- Standards for fall protection
- Fall protection system
- Talk about how to remove the hazard
- Explain what fall protection system involves
- Explain passive vs active systems
- Primary and secondary systems
- Fall protection considerations
- Swing fall and total fall distance
- Fall protection components: body support, connectors, anchorage, and rescue

TRAIN-THE-TRAINER: 2-DAY AERIAL WORK PLATFORM

IN-CLASS

Liftow's Aerial Work Platform Training is designed for both new and

experienced operators. This course will discuss topics relating to the safe use and operation of aerial work platforms including: OSHA legislations, pre-operational inspections, battery care and maintenance.

** Includes a USB with PowerPoint presentation covering a wide range of required course elements. Operator Pre-requisite required.*

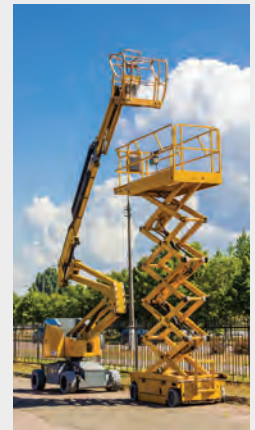

WORKING AT HEIGHTS

NEW! WORKING AT HEIGHTS

IN-CLASS

Our Working at Heights program is approved by the Chief Prevention Officer and is

AT YOUR FACILITY

ONLINE (COMING SOON)

designed for any Ontario workers who may work at heights as part of their job. Anyone working at heights requires fall protection training (Ontario Regulation 213/91).



MATERIAL HANDLING EQUIPMENT

SKID STEER/LOADER TRAINING

IN-CLASS

Some of the topics included are:

AT YOUR FACILITY

- Occupational Health & Safety Act
- Pedestrian Awareness
- Basic Principles & Operation
- Parts of a Loader/Bobcat
- Pre-Shift Operation
- General Safety Rules
- Hoisting Safety
- Hand Signals

OTHER COURSES

- BATTERY MAINTENANCE
- INDUSTRIAL UTILITY VEHICLE (TOW TRACTOR)
- TRANSPORTATION OF DANGEROUS GOODS (GROUND)
- WHMIS TRAIN-THE-TRAINER



A DIVISION OF LIFTOW

S·A·F·E^{LIFT} 2

SAFETY AWARENESS FOR FORKLIFT EQUIPMENT

Coming In 2019!

Available on DVD or USB

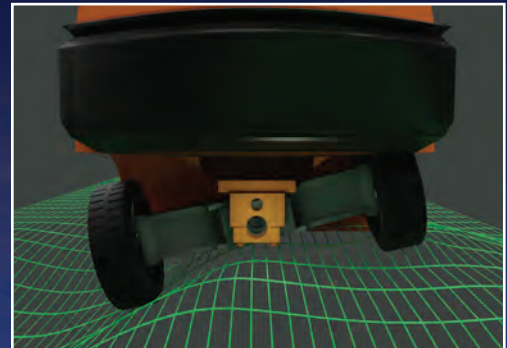

Training Kit Includes:

- Counterbalance Training Video
- Pedestrian Safety Training Video
- What's Wrong With This 2 Video
- (1) Participant's Guide with Wall Certificate & Wallet Card
- (1) 17" x 11" Laminated Safety Poster

New Participant's Guide Features:

- Full color pages with detailed visual training aids
- Extensive workbook with interactive student exercises
- Written exam and practical evaluation
- Full colour wall certificate
- Credit card style wall certificate

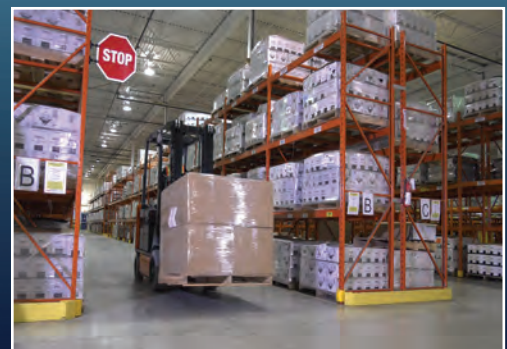
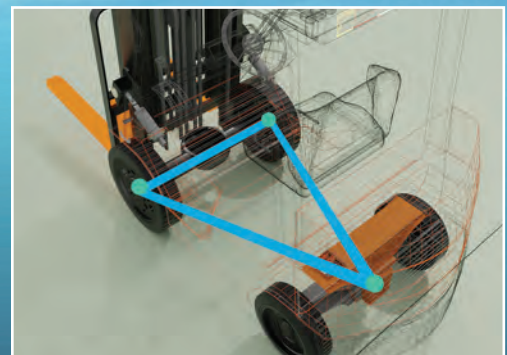

ITEM	DESCRIPTION	PRICE
SL2CBDVD-F	SAFE-Lift 2 Counterbalance DVD Kit	\$399.00
SL2CBUSB-F	SAFE-Lift 2 Counterbalance USB Kit	\$399.00
SL2CBPKG-F	SAFE-Lift 2 Counterbalance Pkg Deal (Pack of 10 Participant's Guides)	\$115.00
SL2CBPG-F	SAFE-Lift 2 Counterbalance Participant's Guide	\$12.50
SL2CBAG-F	SAFE-Lift 2 Counterbalance Administrator's Guide	\$15.00
SL2CBWC-F	SAFE-Lift 2 Counterbalance Wallet Cards (Pack of 10)	\$25.00



SAFE-Lift Counterbalance DVD Kit

Each package includes:

- 1 (45 min) lift truck training video
- 1 (15 min) Danger Zoned
- 1 What's Wrong With This?
- 1 Operator manual
- 1 Operator exam
- 1 Instructor guide
- 10 Certificates (Wall and Wallet)
- 1 (17" x 22") Poster

CC Available

Available on
USB



English (C)CBKDVD-F **\$329⁰⁰**
 Spanish (C)CBKSPDVD-F **\$379⁰⁰**
 French (C)CBKFRDVD-F **\$379⁰⁰**



SAFE-Lift Narrow Aisle DVD Kit

Each package includes:

- 1 (30 min) Training video
- 1 Operator manual
- 1 Operator exam
- 1 Instructor guide
- 10 Certificates (Wall and Wallet)
- 1 (17" x 22") Poster
- Available on USB

CC Available

Available on
USB



English (C)NAKDVD-F **\$329⁰⁰**
 Spanish (C)NAKSPDVD-F **\$379⁰⁰**
 French (C)NAKFRDVD-F **\$379⁰⁰**



SAFE-Lift Pallet Truck DVD Kit

Each package includes:

- 1 (21 minute) video
- 1 Operator manual
- 1 Operator exam
- 1 Instructor guide
- 10 Certificates (Wall and Wallet)
- 1 (17" x 22") Poster
- Available on USB

CC Available

Available on
USB



English (C)PTKDVD-F **\$175⁰⁰**
 Spanish (C)PTKSPDVD-F **\$225⁰⁰**
 French (C)PTKFRDVD-F **\$225⁰⁰**

SAFE-Lift DVD Package

Comes complete with:

- 1 DVD with all Safe-Lift Videos including Danger Zone & "What's Wrong with This?"
- 1 Counterbalance Instructor Guide
- 1 Narrow Aisle Instructor Guide
- 1 Pallet Truck Instructor Guide
- 1 Counterbalance Operator Manual
- 1 Narrow Aisle Operator Manual
- 1 Pallet Truck Operator Manual
- 1 Counterbalance Operator Exam
- 1 Narrow Aisle Operator Exam
- 1 Pallet Truck Operator Exam
- 3 Safety Posters
- 10 Certificates (Wall and Wallet)



Available on
USB

All-In-1 Safe-Lift DVD Training Kit
 CDVDS-F **\$499⁰⁰**

Support Materials (available in french)

Manuals, guides, exams and certificates made for the counterbalance, narrow aisle, and pallet truck video training programs.

ITEM	DESCRIPTION	PRICE
(C)CBOM-G	SAFE Counterbalance Operator Manual	\$7.50
(C)CBOMFR-G	SAFE Counterbalance Operator Manual (French)	\$15.00
(C)CBOE-G	SAFE Counterbalance Operator Exam	\$3.00
(C)CBOEFR-G	SAFE Counterbalance Operator Exam (French)	\$7.50
(C)CBIG-G	SAFE Counterbalance Instructor's Guide	\$10.00
(C)CBIGFR-G	SAFE Counterbalance Instructor's Guide (French)	\$10.00
(C)NAOM-G	SAFE Narrow Aisle Operator Manual	\$7.50
(C)NAOE-G	SAFE Narrow Aisle Operator Exam	\$3.00
(C)NAIG-G	SAFE Narrow Aisle Instructor's Guide	\$10.00
(C)PTOM-G	SAFE Pallet Truck Operator Manual	\$7.50
(C)PTOE-G	SAFE Pallet Truck Operator Exam	\$3.00
(C)PTIG-G	SAFE Pallet Truck Instructor's Guide	\$10.00
(C)CERT-G	SAFE Certificates (10 Wall, 10 Wallet)	\$12.00
(C)CERTFR-G	SAFE Certificates (10 Wall, 10 Wallet) (French)	\$12.00

Package Deal

10 x manuals, 10 x exams, 10 x Wall and Wallet Certificates.

- (C)CBPKG-F Counterbalance Package Deal **\$95.00**
- (C)NAPKG-F Narrow Aisle Package Deal **\$95.00**
- (C)PTPKG-F Pallet Truck Package Deal **\$95.00**
- (C)CBPKGFR-F Counterbalance Package Deal (French) . **\$170.00**

Liftow's training videos are intended to be used as a recommended training aid to compliment our instructor-led training programs.

* Shipping included to most major cities, surcharges may apply to Quebec & Atlantic Canada. Prices are subject to change without notice.

For updated pricing or to place your order online visit: www.liftow.com

TRAINING VIDEOS / DVDS

Ultimate Training Package

Give your instructors the necessary tools for effective lift truck operator training with the Ultimate Training Package.

All-in-One DVD which includes:

- Counterbalance training
- Narrow Aisle training
- Pallet Truck training
- "Danger Zone" pedestrian safety
- "What's Wrong With This?" refresher training
- High Impact Forklift safety DVD
- 10 Operator manuals of your choice
- 10 Operator exams of your choice
- 10 Wall/wallet certificates of your choice
- 1 Lift truck training reference manual
- 1 Model lift truck of your choice
- 1 Wire forklift for training demonstration

Available on



ALSO AVAILABLE IN FRENCH

Ultimate Training Package-DVD

(C)UTPDVD-F..... **\$899⁰⁰**

WHMIS 2015 for Workers: Self-paced Program

As part of your job, you may have to handle, use, store and/ or have to dispose of hazardous chemicals. It is important to know what types of hazardous materials are in your workplace because they contain chemicals that can be dangerous to your health and safety and that of your co-workers and customers. This DVD training program contains the generic WHMIS 2015 information you need to help you work safely with hazardous products. It presents WHMIS 2015 from the worker's point of view so that you can identify and work safely with hazardous materials back on the job.

The WHMIS 2015 system will help you identify hazardous material in your workplace, recognize the hazards of the materials you work with and determine how you can protect yourself from injury and illness.

Everyone who works with or near chemicals is required by law to receive WHMIS 2015 training.

WHMIS 2015 Kit includes:

- Training DVD or USB
- 5 x Participant's Guides with Wall and Wallet Certificates
- Administrator's Guide
- Pictogram Poster

Available on



ITEM	DESCRIPTION	PRICE
GHSDVD-F	WHMIS 2015 For Workers DVD Kit	\$299.00
GHSUSB-F	WHMIS 2015 For Workers USB Kit	\$299.00
GHSDVDUSB-F	WHMIS 2015 DVD and USB Combo Kit	\$324.00
GHSPKG-F	WHMIS 2015 For Workers Package Deal (5 Participant's Guides)	\$59.00
GHSPG-F	WHMIS 2015 For Workers Participant's Guides	\$11.80
GHSAG-F	WHMIS 2015 For Workers Administrator's Guide	\$15.00
GHSWC5-F	WHMIS 2015 For Workers Wallet Cards (Pack of 5 Cards)	\$29.50

Liftow's training videos are intended to be used as a recommended training aid to compliment our instructor led-training programs.

* Shipping included to most major cities, surcharges may apply to Quebec & Atlantic Canada. Prices are subject to change without notice.



Call to order: **1-866-Go Liftow (1-866-465-4386)**

TRAINING VIDEOS / DVDS



Available on USB

Danger Zone Pedestrian Safety DVD Kit

Over one third of all lift truck related accidents involve pedestrians. Establish a pedestrian safety program before a near miss happens!

Kit includes:

- 1 (15-minute) Training video
- 1 Instructor guide
- 2 Laminated safety signs
- 1 (17" x 22") Poster

Danger Zone DVD Kit
DZEDVD-I (English) **\$179⁰⁰**

Danger Zone DVD Kit
DZFDVD-I (French) **\$179⁰⁰**

Scale Model Lift Trucks

These highly detailed model trucks are almost identical to their larger counterparts. These trucks are great for training demonstrations.



Generic LPG Model Truck
CBLT-A **\$40⁰⁰**



Toyota 8-Series LPG
8LT-A **\$65⁰⁰**



BT Narrow Aisle
NALT-A **\$65⁰⁰**



Bobcat Skid Steer Model
6989077-A **\$65⁰⁰**



Available on USB

More High Impact Forklift Safety DVD

Graphical re-enactments of industrial accidents. Great for training your operators on accident awareness and prevention (15 mins).

More High Impact Safety DVD
MHIFS DVD-E **\$350⁰⁰**

More High Impact Safety DVD Spanish
MHIFSPDVD-E **\$350⁰⁰**



Available on USB

What's Wrong With This? DVD

The perfect DVD for refresher training for forklift operators meetings. Watch clips of an operator committing safety infractions. See if your staff can pick out what is being done wrong. It's both educational and fun!

What's Wrong With This DVD
WWT DVD-G **\$49⁹⁵**



Available on USB

ABC's of Fall Protection DVD

This DVD shows viewers how to properly select and use personal fall arrest systems so they can work safely above ground. Topics include forces involved in falls, components of a fall arrest system, inspection of the equipment, calculating fall distance, selection of an appropriate connecting device and the importance of choosing a legal tie-off point.

ABC's of Fall Protection Safety DVD
FALLDVD-E (English) ... **\$350⁰⁰**



Magnetic Stability Training Model

Educating forklift operators on stability principals can sometimes be challenging. The Magnetic Stability Training Model provides a simple way to demonstrate various forklift situations. It easily demonstrates the concept of the center of gravity, various load shapes, steering and top & side views of the forklift stability triangle. Trainers can educate and test thousands of different stability scenarios. Works on any magnetic white or black board.

STABMAG-E **\$39⁹⁵**



Wire Lift Truck

Teach your operators about the center of gravity with this clever training tool. Ideal for lift truck trainers. Galvanized steel 4" W x 5" H.

Wire Lift Truck
WRLT-D **\$99⁹⁵**

Liftow's training videos are intended to be used as a recommended training aid to compliment our instructor-led training programs.

* Shipping included to most major cities, surcharges may apply to Quebec & Atlantic Canada. Prices are subject to change without notice.

For updated pricing or to place your order online visit: www.liftow.com

TRAINING VIDEOS / DVDS



SUPPORT MATERIALS INCLUDED!

Available on **USB**

Lockout/Tagout DVD Program

Lockout/Tagout is the most effective way to control hazardous energy and is required by law when performing tasks such as the maintenance, repair and cleaning of any piece of equipment.

Each Lockout/Tagout Kit includes:

- 1 Lockout/tagout DVD
- 5 Participant guides (including quiz)
- 1 Administrator guide, 5 wall certificates
- 1 Lockout/tagout poster
- 1 Health and safety action plan

Research indicates that the uncontrolled release of hazardous energy causes more than 100 fatalities and 60,000 injuries each year.

LOTOPDVD-G **\$199⁰⁰**

Propane Cylinder Exchange Training Program

Train your employees on how to deal with propane safety. This in-depth, self-study program covers everything your in-house trainer needs.

What's Included:

- 1 instructional DVD
- 1 participants test
- 1 record of training
- 1 propane safety poster
- 1 participants manual
- 1 propane safety sticker

PROKDVD-G **\$150⁰⁰**



SUPPORT MATERIALS INCLUDED!

Available on **USB**

SkidSteer DVD Training Kit

Kit Includes: Administrator's Guide, 5 Manuals, 5 Wall and Wallet Certificates.

SkidSteer Instructional DVD Kit
7249275-C **\$325⁰⁰**

SkidSteer Package Deal - English (10 Participants Guides and 10 Certificates)
7249276-C **\$295⁰⁰**



Versa Handler DVD Training Kit

Kit Includes: Administrator's Guide, 5 Manuals, 5 Wall and Wallet Certificates.

Versa Handler DVD Kit
6901184-C **\$625⁰⁰**

Versa Handler Package Deal (5 Participants Guides and 5 Certificates)
6901185-C **\$195⁰⁰**

Aerial Work Platform Training DVD Kit

This comprehensive Genie Boom Aerial Platform Operator Training program includes safe operating procedures for Aerial Work Platforms, Scissor Lifts, Articulation booms, Telescopic Booms and Trailer Mounted Booms.

Each Kit comes complete with:

- Aerial Platform Operator Training DVD
- Aerial Platform Operator Training CD Rom
- Trainers Guide
- Participants Guide
- Responsibilities Manual
- Operator Manual on Scissor Lifts, Articulating Booms, Telescopic Booms, Trailer Mounted Boom

Aerial Work Platform Training Kit
217746-D **\$475⁰⁰**



Available on **USB**

Back Safety 101

This back safety DVD will help your employees identify ways in which they may be harming their backs. This video also offers simple solutions to improve ergonomics in the workplace.

Back Safety 101 DVD
BS101DVD-G **\$49⁰⁰**



Rough Terrain Training DVD Kit

Includes: Straight Mast & Truck Mount Rough Terrain Forklift DVD, Instructor's Guide, Agenda, Objectives and Goals Sheet, Instructor's Resource Guide, Evaluation Test, Evaluation Log Book, 5 Student Operator's Workbooks, 5 Operator Certificate of Completion, 5 Operator Wallet-Size Completion ID Cards, Visual Aids (PowerPoint Disk, Overheads, Charts).

TK001-C **\$475⁰⁰**

Rough Terrain Package Deal (5 Manuals/5 Certificates)
SM001-C **\$199⁰⁰**

Liftow's training videos are intended to be used as a recommended training aid to compliment our instructor led-training programs.

BATTERY SAFETY

The Dissipater Replacement Battery Cap

Battery maintenance has never been this easy. The Dissipater is a revolutionary battery maintenance cap that offers you five time saving advantages.

- Reduce Watering Intervals
- Instant Electrolyte Level Indication
- Prevent Acid Overflow
- Ergonomic Easy On/Off Switching
- Filters Harmful Battery Emissions

Quantity discounts available!

The Dissipater **\$8⁵⁰**

DISSA-C (BBI, C&D, Crown, GNB batteries) DISSB-C (EXIDE, and General batteries)



Frotek Aqua Low Profile Battery Watering System

Save time and increase safety with the Aqua Low Profile Battery Watering System. The low profile battery caps are specially engineered to fit most of the forklift battery brands on the market. This simple and reliable design allows the battery watering system to operate with only two moving parts. The Fluid Level Indicator shows the watering requirements for each cell at a glance and the single point delivery reduces battery watering time dramatically. Note: A Pressure Regulator is required to use the battery watering systems.

- Quick and easy one point connection
- Prevents over-filling of battery cells
- Prevents missed watered battery cells
- Ensures correct water level
- Increases safety
- Polycarbonate construction

ITEM	DESCRIPTION	PRICE
AQLP4-6-B	12 volt, 6 cells	\$135.00
AQLP4-12-B	24 volt, 12 cells	\$220.00
AQLP4-18-B	36 volt, 18 cells	\$300.00
AQLP4-24-B	48 volt, 24 cells	\$400.00
USPRGKIT-A	Pressure regulator, refilling hose (required)	\$175.00

Note: GNB brand of batteries require a different system. Please call for pricing on replacement and accessory parts.

Battery Watering Gun

Just insert into the battery cell and pull the trigger. Automatically fills the cell to the correct level, then shuts off. Never overfill a battery cell again.

SFS-100-D **\$125⁰⁰**



Watering Gun Buddy



- Durable polypropylene casing
- Includes handy swivel wall mount bracket
- Installs in minutes
- 50' length retractable 1/2" PVC hose with auto-locking and release
- Hose guide system provides a slow, controlled retraction
- Working pressure of 150 PSI
- Features an easy quick connect on the end of the hose for the watering gun



Watering Gun Buddy Kit with Watering Gun

WGBKIT-C **\$225⁰⁰**

Watering Gun Buddy Retractable Hose Reel Only

WGB15-C..... **\$129⁹⁵**

* Shipping included to most major cities, surcharges may apply to Quebec & Atlantic Canada. Prices are subject to change without notice.

For updated pricing or to place your order online visit: www.liftow.com

BATTERY SAFETY



Watering Cart

This 10-gallon watering cart contains a battery, charger and a built-in 12 volt pump that automatically turns off when fill lever is shut off. Watering gun sold separately.

**Shipping included*

CARTW-C.....**\$1,220⁰⁰**

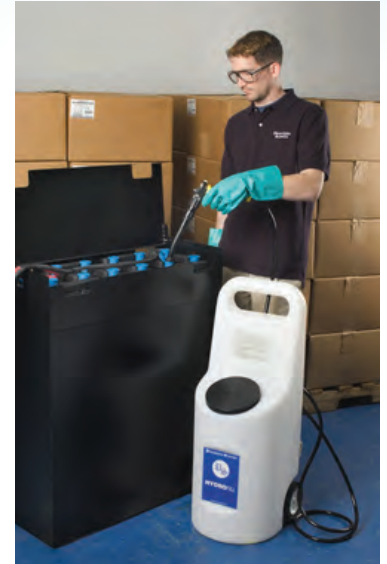

De-Ionizer Battery Water Filtration System

Removes iron and other trace minerals that can shorten battery life. One cartridge cleans approximately 600 gallons.

DW-KIT-D.....**\$595⁰⁰**
 DW-CAR-D (replacement cartridge)**\$295⁰⁰**

Heat Shrink PVC Battery Cable Protector

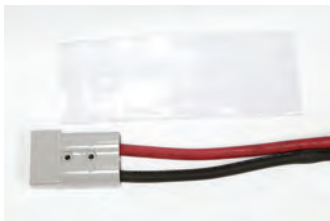

Step 1: Cut heat shrink to desired length.



Step 2: Fit heat shrink over connector and cable.



Step 3: Apply heat gun to heat shrink.



Step 4: While still warm, place back into connector so heat shrink will cool to desired shape.

- 2.5" Heat Shrink forms over SB350 connector and cable
- Protects cables and connector from damage
- Allows personnel to separate connectors safely when pulling from the cables
- Prevents damage to cables when pinched by hood

2.5" with 2:1 shrink ratio 12"
 HSPVC12-G.....**\$14⁰⁰**

2.5" with 2:1 shrink ratio 18"
 HSPVC18-G.....**\$21⁰⁰**

Battery Acid Spill Kit

Each kit includes:

- 1 red nylon bag
- 10 sorbent pads
- 3 sorbent socks 3"x 48"
- 2 disposable bags
- 1kg acid neutralizer
- 1 drain cover
- 1 epoxy stick
- 1 pair nitrile gloves
- 1 pair goggles
- 2 hazardous waste labels



CSKBATT-LT-C **\$215⁰⁰**

Bio Med Wash for First Aid Eyewash



Bio Med Wash is a sterile, heavy mist containing 100% Bio-Logic, all-natural, pH correct pure tissue-culture grade of water. Great for emergency first aid eye wash and irrigation and washing dirt from cuts and lacerations.

Bio Med Wash 7oz Can
40006-C **\$21⁹⁵**

Bio Med Wash – 2 Twin 7 oz Cans with Mirror
47093-C **\$85⁰⁰**

Wall Mount Bracket
47086-C **\$12⁹⁵**

Gravity Feed Eye Wash

Mounts to any wall with its highly visible yellow polyethylene for long life. Pull-down tray stays in fixed position during activation. Will allow 15 minute flow at 0.4 gpm output.



**BONUS!
HYDROSEP
INCLUDED**

1104050-A **\$450⁰⁰**

YellowBowl™ Shower/Eye Wash

- Combination Shower/Eyewash Station
- Full Body
- Plastic Shower
- Self-Adjusting Regulators Assure 8 GPM flow on Eyewash and 30 GPM flow on shower

1050216-A **\$1,360⁰⁰**



Emergency Shower & Eye Wash Sign
FREE! with the Yellow Bowl™ Shower/Eye Wash



Yellow Bowl™ Eye Wash

This unit connects directly to the water line to provide an uninterrupted flow. Comes with two ABS plastic heads and 10.5" bowl. Push plate actuator opens water valve. Connects to 1/2" NPT water line.

1030401-A **\$450⁰⁰**

Hydrosep Water Treatment Additive

Reduces harmful bacteria and organisms in water supply for 90 days. One bottle treats 5 - 10 gallons. Sold in a package of 4 bottles.

1110764-A **\$55⁰⁰**



* Shipping included to most major cities, surcharges may apply to Quebec & Atlantic Canada. Prices are subject to change without notice.

BATTERY SAFETY

The Battery Care Box



Proper battery care requires special tools and personal protection equipment in order to do the job right. The Battery Care Box puts it all together for you in one box. MSDS information requires specific personal protection equipment since all forklift batteries contain sulfuric acid. This acid often escapes in normal use and comes in contact with skin or eyes if unprotected. Protect your workers that need to service batteries in your workplace.

- Face Shield
- Goggles
- Apron
- Neoprene Gloves
- Flashlight
- Hydrometer
- "No Smoking" Sign
- Cap-Off Battery Cap Removal Tool
- Batt 1000 Battery Cleaner and Acid Neutralizer
- Acid Spill Neutralizer
- Plastic Storage Box

BATBOX-C **\$210⁰⁰**

Complete Battery Handling PPE Kit



This complete Battery Personal Protection Equipment Kit mounts conveniently on any wall so that everything is within easy reach. The self-contained kit comes with: neoprene safety gloves, safety goggles, face shield, apron, flashlight, hydrometer and a cap-off removal tool. Board size: 34" W x 20" L.

Complete Battery Handling PPE Kit

BCHG-E **\$124⁹⁵**
 BCHGFR-E (French) **\$124⁹⁵**

Fact! All MSDS information sheets require this PPE when working around sulfuric acid.

ITEM	DESCRIPTION	PRICE
POS(B)-C	Board Only	\$45.00
NEO-C	Neoprene Gloves	\$12.95
SHLD-C	Face Shield	\$21.95
APRN-C	Safety Apron	\$14.95
GOGG-C	Safety Goggles	\$8.95
HYDR-C	Hydrometer	\$21.95
MH9900F-E	Cap-Off	\$14.95
FLSH-C	Flashlight	\$3.00

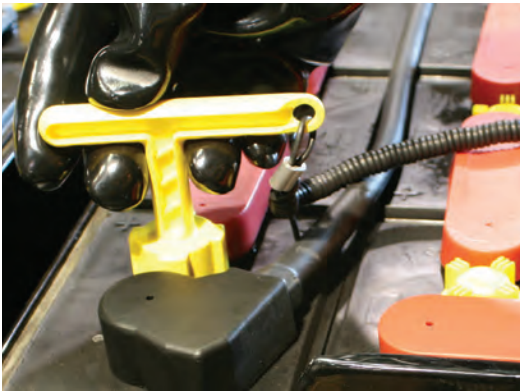

Cap-Off Battery Cap Removal Tool

- Removes all types of battery caps quickly and easily
- Eliminates hand contact with acid soiled caps
- The ergonomic solution to check water levels in your battery
- Holds cap in tool for quick re-installation

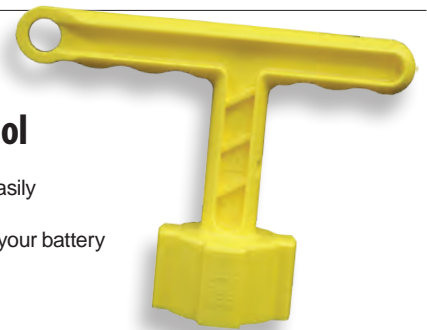

MH9900F-E **\$14⁹⁵**

Battery Cable Tower

Pogo stick style cable retractor (40" high) mounts to battery stands or wall brackets. Spring on bottom allows forklift operators to pull charger cables to their truck battery. When driver unplugs connector from battery, the retractor returns to upright position keeping connectors from shattering on the floor. Comes with all hardware to install.



127600-C..... **\$129⁹⁵**

Battery Sling

This 2" x 5' Battery Changing sling has been designed to hook onto the eye bolt holes on both sides of the battery. Attach the Battery Sling to a forklift truck to facilitate lifting the battery out of the truck.



- 2-ply polyester sling webbing
- Working Load Limit: 5,000 lbs

BS22-05-D..... **\$159⁰⁰**



Batt 1000 - Battery Cleaner and Protector

Formulated to penetrate and emulsify dirt, grease and corrosive deposits (acid) to protect and to lengthen the life of your battery. A safe, fast and convenient method of neutralizing battery acid. Just spray and wipe clean with a rag.

B1000-E..... **\$14⁹⁵**

Batt 1000 (Case of 12)

B1000-12-E..... **140⁰⁰**



Battery Lifting Beam

This battery lifting beam with a standard 6,000 lb. capacity is designed to fit 27-42" industrial batteries. Lifting hooks are adjustable to fit most batteries. Lifting Beam can be used in conjunction with a fork mounted hook plate (see below).

BLB6000-B **\$1,280⁰⁰**

Shipping included!*



Battery Cable Magnet

Hold battery cable in place with 100-lb magnet. Prevents cable and connector damage by keeping them where you want them.

CABLEMAG-D **\$27⁹⁵**



Fork Mounted Hook Plate

The Lift-Master Hook Plate enables any fork truck to maximize safety while lifting a load using chains, cables or ropes. The safety restraint is used to secure the hook plate to the fork truck, preventing it from sliding off the end of the forks. Fork openings are 6-1/4"W x 1-3/4"H. 6,000 lb. capacity.

LM-HP6-S-B **\$465⁰⁰**

Shipping included!*



Battery Cable Connectors

The 175 Amp and 350 Amp Battery Connector Kit come complete with high strength polycarbonate housing, (2) silver plated connector lugs and convenient connector handle.

Dimensions:

- 175 Amp Connector: 3.13" x 2.19" x 1"
- 350 Amp Connector: 4.25" x 2.75" x 1.31"

Specifications:

- Impact resistant polycarbonate construction
- Silver plated lugs offer superior conductivity
- Stainless steel retaining springs secure contacts in housing for a consistent connection
- Mechanical keys in housing help prevent mating of different color connectors
- Voltage rating: 600V
- UL Rated

ITEM	CONNECTORS WITH LUGS	PRICE
350GRKIT-E	SMH 350 Amp Connector Grey Plastic Housing with 2/0 Lugs and Handle	\$19.95
350REKIT-E	SMH 350 Amp Connector Red Plastic Housing with 2/0 Lugs and Handle	\$19.95
175GRKIT-E	SMH 175 Amp Connector Grey Plastic Housing with 1/0 Lugs and Handle	\$15.95
175REKIT-E	SMH 175 Amp Connector Red Plastic Housing with 1/0 Lugs and Handle	\$15.95
350GRL2-E	SMH 350 Amp Connector Grey Plastic Housing with 2/0 Lugs	\$16.95
350REL2-E	SMH 350 Amp Connector Red Plastic Housing with 2/0 Lugs	\$16.95
175GRL1-E	SMH 175 Amp Connector Grey Plastic Housing with 1/0 Lugs	\$12.95
175REL1-E	SMH 175 Amp Connector Red Plastic Housing with 1/0 Lugs	\$12.95
CONNECTORS ONLY		
350GR-E	SMH 350 Amp Connector Grey Plastic Housing Only	\$11.95
350RE-E	SMH 350 Amp Connector Red Plastic Housing Only	\$11.95
350BL-E	SMH 350 Amp Connector Blue Plastic Housing Only	\$11.95
175GR-E	SMH 175 Amp Connector Grey Plastic Housing Only	\$8.95
175RE-E	SMH 175 Amp Connector Red Plastic Housing Only	\$8.95
HANDLES ONLY		
HANGR-E	350/175 Amp Grey Connector Handle	\$8.95
HANRE-E	350/175 Amp Red Connector Handle	\$8.95

* Shipping included to most major cities, surcharges may apply to Quebec & Atlantic Canada. Prices are subject to change without notice.

For updated pricing or to place your order online visit: www.liftow.com

BATTERY SAFETY

Battery Roller Service Stands

- Widths range from 15-24"
- Measures 40" deep



Designed for removal of a battery for watering and maintenance.

- Welded steel construction
- Non-conductive
- Acid resistant
- PVC covered steel rollers
- 7/8" adjustable legs
- C/W floor lag plate
- Battery safety stops
- Acid resistant black paint
- Wood shelf inlay



Battery Service Stands

BSS-15-A (15" width).....	\$745⁰⁰
BSS-18-A (18" width).....	\$760⁰⁰
BSS-22-A (22" width).....	\$800⁰⁰
BSS-24-A (24" width).....	\$840⁰⁰

Note: when ordering, specify height from floor to top of roller.

ITEM	WIDTH	PRICE
DOUBLE STANDS		
BSS-15-2-A	15"	\$1,220.00
BSS-18-2-A	18"	\$1,290.00
BSS-22-2-A	22"	\$1,335.00
BSS-24-2-A	24"	\$1,430.00
TRIPLE STANDS		
BSS-15-3-A	15"	\$2,245.00
BSS-18-3-A	18"	\$2,620.00
BSS-22-3-A	22"	\$3,010.00
BSS-24-3-A	24"	\$3,235.00

Shipping included!*

Battery Transfer Cart

The Battery Transfer Cart is designed for use with pallet trucks to load, unload and transfer fork truck batteries. Features roller deck for easy battery movement. Front locking safety tabs to secure battery in cart. Pallet truck is not included. Welded steel construction with powder coat yellow finish.

Optional winch attachment, model BTC-WINCH, can be installed easily with the supplied hardware. The manual winch is designed to pull battery out of fork truck.



ITEM	DESCRIPTION	OVERALL SIZE (W x D)	CAP.(LBS)	NET	PRICE
BTC-PJ-B	FOR USE W/PALLET TRUCK	32" x 42"	4,000	140	\$1,605.00
BTC-WINCH-B	WINCH ATTACHMENT	52"H	--	30	\$195.00

Battery Roller Service Stands with Charger Shelf

Designed as a complete service charging station. Ideal for keeping chargers up to 800 pounds in a safe place off the floor.

ITEM	WIDTH	PRICE
DOUBLE STANDS WITH CHARGER SHELF		
BS-15-2-CS-A	15"	\$1,720.00
BS-18-2-CS-A	18"	\$1,860.00
BS-22-2-CS-A	22"	\$2,130.00
BS-24-2-CS-A	24"	\$2,275.00
TRIPLE STANDS WITH CHARGER SHELF		
BS-15-3-CS-A	15"	\$2,410.00
BS-18-3-CS-A	18"	\$2,785.00
BS-22-3-CS-A	22"	\$3,180.00
BS-24-3-CS-A	24"	\$3,400.00

Note: when ordering, specify height from floor to top of roller.

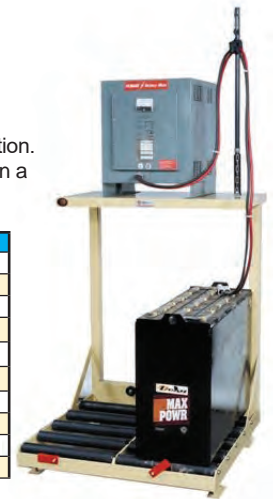

Wall Mounted Charger Brackets

Reduces floor damage of chargers and allows for a clean and safe floor area (universal fit).

*Charger not included

WMCB-25-18-A **\$145⁰⁰**



Carbon Monoxide Detector Passive Multi-Level CO Detector



- Minimum 18-month product life
- Multi-level detection: normal, caution & danger
- Perfect for the warehouse, office or confined space area
- Unique packaging protects sensor from contamination
- This visual detector is about the size of a credit card

CARB-E..... **\$25⁰⁰**

Brass Coupler

- Standard coupler 1-1/4" x 1/4" FNPT
- Brass and steel construction
- Connects directly to the forklift propane hose
- UL Listed



COUPLER-C..... **\$22⁹⁵**

Complete Propane PPE Kit

Personal Protective Equipment for Liquid Propane Gas

The PPE for LPG contains all of the required PPE to change propane tanks. Each kit comes complete with a pair of safety gloves, safety glasses, a leak detector and a full set of easy-to-follow instructions. The wall board can be mounted in the propane changing area.



PPEB-E..... **\$95⁰⁰**

Leak Detection Compound

LEAVES NO RESIDUE!

Test your propane junctions and hoses safely with this specially made compound. Just a few drops and this compound spreads quickly, providing a long lasting foam exposing the point of leakage.

A must-have for propane powered equipment operators.



LEAK-C..... **\$16⁹⁵**

LPG Safety Grip

Take the LPG Coupler On & Off Easier and Safer!

Helps prevent serious thermal injury burns from escaping liquid propane. The LPG Safety Grip is a soft rubber boot that easily fits over the brass coupler.

- Provides protection against escaping liquid propane gas as it redirects liquid propane away from the operator's hand
- Rubber grip makes it easier to tighten and loosen the coupler
- Installs in minutes over all 1-1/4" couplers



Note: The LPG Safety Grip does not eliminate the required PPE for changing LPG cylinders.

SAFEGRIP-C..... **\$22⁹⁵**

Brass coupler not included.

Propane Cylinder Handling Gloves



Operators are required to wear proper hand protection when exchanging propane cylinders. The PVC Propane Gloves are used to safely exchange propane cylinders and helps prevent any injuries to the operator's hands. Extremely cold propane can cause frost burn to exposed skin and can ultimately cause nerve damage if no protection is worn. The PVC Gloves include chains and wires to conveniently attach to the overhead guard and allow easy access for operators. The gloves are hung on a magnetic hook when not in use.



OHBD-E..... **\$34⁹⁵**

Retracto-Glove For Propane Forklifts



Operators are required to wear proper hand protection when exchanging propane cylinders. The PVC Retracto-Glove is used to safely exchange propane cylinders and helps prevent any injuries to the operator's hand. Extremely cold propane can cause frost burn to exposed skin and can ultimately cause nerve damage if no protection is worn. Retractable and ready to use, the Retracto-Glove is attached to a spring loaded chain and installs in seconds without any tools. The glove is hung on a magnetic hook when not in use.



RETRC-E..... **\$34⁹⁵**

* Shipping included to most major cities, surcharges may apply to Quebec & Atlantic Canada. Prices are subject to change without notice.

PROPANE SAFETY

Low Propane Fuel Gauge



The Low Propane Fuel Gauge is a new patented technology that senses when the cylinder has approximately one half gallon of LPG left in the cylinder.

This gives the forklift operator 20 - 30 minutes advanced notice to complete the job and exchange cylinders in a safe area.

LPFG-B **\$249⁰⁰**



*Running Out of Propane is Never Productive or Safe!
Get a 20 Minute Warning Before You Run Out!*



Time to Change Tank

With the low propane fuel gauge, the red light will indicate when propane changes from a liquid state to vapor state.



LP Cylinder Loader

- Allows pick-up & placement of tanks on forklift
- Designed to transport and store up to 6 full LP tanks
- Collapses for easy storage
- Powder coated for long-term wear
- Easy set-up and operation
- 360° swivel boom|

Shipping included!*

LP-6-A **\$4,605⁰⁰**

Propane Cylinder Equipment Caddies



6 HOLDS FULL LP TANKS!

- Move cylinders safely
- Designed to transport and store up to 6 full LP tanks
- Accommodates cylinders 12"D x 24"H
- Size: 27" x 31" x 29"

Shipping included!*

LP-170-A **\$1,240⁰⁰**



Single Propane Cylinder Cart

Move propane cylinders safely and efficiently from the storage area to the lift truck.

- Loop Handle
- 14" x 45" Overall Height
- Weight 27 lb.
- 10" solid rubber wheels

701-10PN-C **\$225⁰⁰**

Low Propane Fuel Indicator Kit

- Warns operator of low propane fuel
- Fits all propane systems
- 12 volt system
- Comes with warning indicator light
- Audible alarm option available
- Red light on dashboard will activate once the propane cylinder is close to empty



N15-0013-1A-A **\$80⁰⁰**

Low Fuel Indicator Kit w/ Audible Alarm
N15-0012-1A-A **\$95⁰⁰**

Propane Cylinder Storage Cabinets

- All steel construction/rust resistant
- Heavy duty steel angle frame
- 8 gauge galvanized wire
- Horizontal or vertical storage available



6 Cylinder Capacity (42.5"W x 25.5"L x 37"H)
GS-6 **\$865⁰⁰**

**Cabinet may be different than shown*

12 Cylinder Capacity (30"W x 39"L x 72"H)
GS-12 **\$1,025⁰⁰**

EZ-FIT COMFORT HARNESS

The EZ-Fit Comfort Harness is a perfect economical solution to achieving supreme operator comfort when working with heights. Rated for up to 400 lbs user.



Comfortable, supportive padding on back, shoulders and legs.



Extended D-Ring with velcro strap.



Highly reflective strapping throughout.



Quick connect bayonet style buckles.



BONUS!

*Harness Bag included with all harness and lanyard combo purchases.

- EZ-FIT Harness & 6' Lightweight Lanyard Combo**
EZFIT-C..... **\$189⁹⁵**
- EZ-FIT Harness Only**
EZHAR-C..... **\$140⁰⁰**
- EZ-FIT Extra Large Harness Only**
EZHARXL-C..... **\$140⁰⁰**

*Harness is CSA approved and OSHA/ANSI compliant.

EZ-Fit 6' Retractable Lanyard

The EZ-Fit 6' Shock Absorbing retractable lanyard prevents snagging and tripping by staying behind and out of the way of the worker. The retractable webbing will instantly arrest a free fall within inches rather than the 3 1/2 feet needed for the traditional lanyard.

- Features:**
- Inner core shock absorber smoothly expands to absorb shock and prevent injury
 - Unique tamper signalling system alerts workers to a previously deployed lanyard
 - Built-in swivel prevents lifeline from twisting
 - Rated for up to 400 lbs. user
 - EZ twist-lock carabiner
 - EZ Locking snap hook – 3/4"

EZRET-C..... \$215⁰⁰

*Lanyard is CSA approved and OSHA/ANSI compliant.



EZ-Fit Lightweight Shock Absorbing Lanyard



The shock absorbing safety lanyard features nylon webbing that is not only durable it is also extremely lightweight which reduces worker fatigue.

- Features:**
- Available in 4' or 6'
 - Prevents injury in the event of a fall
 - Simple and practical
 - Max Fall Arrest Force: 900 lbs.

- EZ-Fit 4' Lightweight Lanyard**
EZLAN4-C..... **\$80⁰⁰**
- EZ-Fit 6' Lightweight Lanyard**
EZLAN6-C..... **\$80⁰⁰**

*Lanyard is CSA approved and OSHA/ANSI compliant.

Rite-On Harness

The Rite-On Harness is designed for simplicity and comfort. The bayonet connectors allow users to connect their chest and leg straps in a single action.

Features Include:

- Integrated back and shoulder pad - conforms to the wearer's shape to provide all-day comfort
- Fast Action Bayonet style connectors - allows quick and easy donning
- Extended D-ring option
- Sweat wicking pad fabric - keeps wearers comfortable in hot conditions
- Tangle free pad design - harness keeps in shape between use, aiding quick and easy donning
- Lightweight polyester webbing
- Universal size with full adjustability - one size fits most
- CSA approved and ANSI/OSHA compliant



FP81F/1EDBA-A \$379⁰⁰

HARNES & LANYARD SET IN ONE!



Safety Harness & Lanyard Combo

The full body harness comes complete with a 6 foot detachable shock-absorbing lanyard. The full body harness is made of lightweight, durable polyester webbing with fully adjustable straps to fit most workers. Meets with applicable OSHA, ANSI and CSA Standards.

Features:

- Lightweight, durable polyester webbing
- Fully adjustable designs
- Sliding back D-ring
- Sub-pelvic strap

ITEM	DESCRIPTION	PRICE
SFPTK4051Q-C	Harness and Lanyard Combo	\$149.95
FP759/1DP-C	Safety Harness ONLY	\$114.95
SFP6SALQ-C	Lightweight 6' Lanyard ONLY	\$104.95

* Shipping included to most major cities, surcharges may apply to Quebec & Atlantic Canada. Prices are subject to change without notice.

For updated pricing or to place your order online visit: www.liftow.com

FORKLIFT SCALES



Hydraulic Scale

SAFE-WEIGH: Lift Truck Check Weigh System



The SAFE-WEIGH series on-board weighing system is designed to give high accuracy at a budget price. This microprocessor based weight system is connected to the hydraulic lifting system on lift trucks or similar machines. A load can be placed on the forks and can be accurately weighed by measuring the hydraulic pressure. Designed for heavy industrial use, the lift truck can weigh a load in under 15 seconds.

This will ensure your shipments will not exceed trailer capacity, way-bills match actual weight, lift truck capacity is not exceeded, or material inventory matches actual weight. Once you use the SAFE-WEIGH, you will wonder how you managed without it. **The SAFE-WEIGH is accurate to +/- 1% of the lift truck capacity.**

Features:

- Stainless steel case and transducer
- Easy to read, user friendly
- External on/off switch
- Selectable capacity and division sizes
- kg. or lb. unit is selectable
- Capacity up to 99,999 lb.
- 1 year warranty
- 12-48V Operating Voltage

Functions:

- Tare Weight (zero out container weight)
- Total Weight (totals the weight of many pallets)
- Over Weight Alarm if load exceeds lift truck capacity

Note: No DC-DC converter required for 24-48V electric trucks. Not legal for trade.

SAWE-C..... **\$2,350⁰⁰**

Pallet Truck w/ Scale - 99.9% Accurate

ACCURACY AT A GREAT VALUE!



The Pallet Truck with Scale allows you to weigh your load as you are handling it. The frame uses heavy-duty steel construction for maximum strength and durability. This model is very user friendly and is suitable for low height lifting. Standard with an on-board charger and AC adaptor.

- Capacity is 5,000 lb.
- Load cells built into forks
- 99.9% accurate
- Mettler Toledo TM scale
- Service range: 3" to 7.5"
- 40 hours continuous battery use (approximately)
- Push-button tare, clear and zero
- Programmable auto shut-off
- Available in lbs. or kg.
- Not legal for trade



Pallet Truck Scale 21"W x 47.5"L
PM-2048-SCL-LP-B **\$3,740⁰⁰**

Pallet Truck Scale 27.5"W x 47.5"L
PM-2748-SCL-LP-B **\$3,740⁰⁰**

Pallet Truck Scale with Printer 21"W x 47.5"L
PM-2748-SCL-LP-PT-B **\$4,300⁰⁰**

U-Shaped Platform Scale

This scale is designed to handle pallets, and is easy to move and store. Ideal for moving around the work place where there is not enough room for a fixed scale. Scale is suitable for weighing in a warehouse, storehouse, or general use. Includes two (2) wheels and handle for easy portability. Equipped with four (4) heavy duty load cells and a deluxe indicator head. Display powered by 115V AC, cord included. Overall size is 48" x 56" x 4 3/4". Surface width is 5" wide. Constructed of heavy-duty steel. 6,000 lbs capacity.



U-Shaped Platform Scale
VPU-6-B..... **\$2,785⁰⁰**

Shipping included!*

Portable Floor Scale Shipping included!*

Portable Floor Scales are ideal for easy transportation and weighing of goods at multiple locations. Non-slip diamond plate surface. Fold down low gradual ramps are fixed to the platform. Ramps make the scale ideal for wheeling pallet trucks, dollies, carts and containers on and off the platform. Four alloy steel load cells and deluxe stainless steel indicator head. Supplier flat pack for easy assembly. Indexing accuracy is 1.1 pounds.

ITEM	PLATFORM SIZE	CAPACITY	PRICE
VPFS-3B-B	39 1/2"x47 3/4"	3,000 lbs	\$5,280.00
VPFS-3C-B	60"x60"	3,000 lbs	\$5,990.00



Brite-Lite LED Forklift Headlight

LED Headlights will almost never have to be serviced. The Brite-Lite is perfectly suited for rough forklift applications including high impacts and vibration. The LED light lifespan is rated for 50,000 hours compared to 5,000 hours for incandescent lights. The Brite-Lite uses (2) 10-Watt Cree LEDs at an operating voltage of 9-64V. Manufactured with a Potted Circuit Board to increase the life of the light and an aluminum housing with heat dissipation fin on the back. Includes bracket to install multiple units together for added brightness.

- (2) 10W Cree LED's
- 50,000 Hour Lifespan
- Brightness: 1500 lumens
- Operating Voltage: 9 - 64V
- Size: 4.33" x 3.58" x 2.42"



BRITELITE-C **\$80⁰⁰**

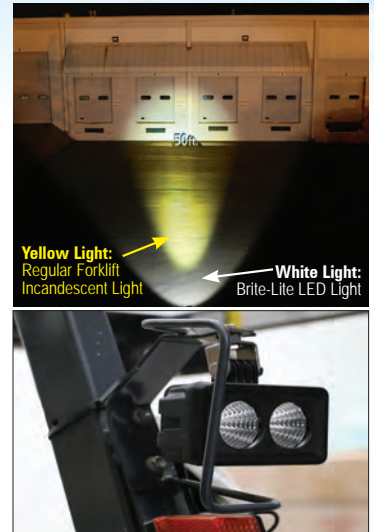

Red-Zone LED Pedestrian Warning Light

40% of all forklift accidents involve a pedestrian. Ensure pedestrians stay a safe distance away from the lift truck with the Red-Zone LED Warning Light. The Red-Zone emits a red beam on the floor to keep pedestrians away preventing foot injury or collisions from rear end swing. The Red-Zone combined with the Blue Light (SAFE-LITE-C) offers a complete pedestrian warning system for your warehouse.

- Operating Voltage: 9 - 64V
- UL Rated
- Size: 6" x 2.25" x 2.75"
- Easy Installation
- Includes Mounting Hardware
- Lifetime Warranty
- 100,000 hrs Lifespan
- PC Lens Material



REDZONE-C **\$129⁹⁵**



ECO LED Forklift Headlight

The ECO LED Headlight is economically priced to replace all the incandescent forklift headlights in your lift truck fleet. It offers a long life of 50,000 hours which means you will never have to replace bulbs again. 500 lumens of light will give off a luminous, clear light without blinding pedestrians working alongside the forklift. The ECO LED Headlight is great for all applications and lift truck models.

- Voltage: 9-64V
- Power: 6 x 3W, 18W
- Operating Temp: -40 F to 185 F
- Lifespan: 50,000 hrs
- IP67 - Dustproof, Waterproof, Shatterproof
- Material: Dicast aluminum housing
- Bracket: Stainless Steel
- Lens: PC
- 2-year replacement warranty

EHD-C **\$55⁰⁰**

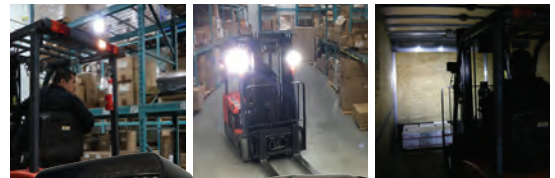

** Can be mounted on the rear of the truck*

** Shipping included to most major cities, surcharges may apply to Quebec & Atlantic Canada. Prices are subject to change without notice.*

For updated pricing or to place your order online visit: www.liftow.com

LED LIGHTS



SAFE-LITE *High Quality Pedestrian Alert Blue Light*

The Safe-Lite alerts pedestrians of forklifts approaching blind corners or forklifts entering and exiting trailers. The Blue LED light projects an intense spotlight 10 to 20 feet ahead of the forklift to alert the pedestrian of nearby traffic. The Safe-Lite can be installed on the front or back of any forklift, sweeper or any other piece of industrial equipment. Includes mounting bracket and straps for easy installation.

- SAFELITE-F(Blue)..... **\$149⁹⁵**
- SAFELITE-R-F(Red)..... **\$149⁹⁵**
- MAGNET-E..... **\$8⁵⁰**



BIG BLUE

This unique "Big Blue" Pedestrian warning light shines a bright light 5 times larger than the conventional Blue Light. With 4 Phillips LED lights, it creates a Big Blue spot on the floor alerting pedestrians of oncoming forklift traffic.

This light comes complete with a mounting bracket for quick and easy installation.

- BIGBLU-F..... **\$149⁹⁵**
- MAGNET-E..... **\$8⁵⁰**



ECO BLUE

The Eco-Blue light provides an economical solution to alert pedestrians of oncoming forklifts. This blue light shines a bright blue spot on the floor warning pedestrians of forklifts approaching from blind corners or trailers.

Each Eco-Blue Light comes complete with a mounting bracket for easy installation. The Eco-Blue can be mounted on either the front or the rear of the forklift.

Waterproof, dustproof and shockproof.

- EBL-H (Blue)..... **\$119⁹⁵**
- ERL-H (Red)..... **\$119⁹⁵**
- MAGNET-E..... **\$8⁵⁰**



ARROW BLUE *Indicates Direction of Moving Vehicle*

The Arrow Blue Light projects a large, bright arrow on the ground 10 to 20 feet away in front or in back of the lift truck. This not only alerts the pedestrian of a nearby lift truck, but also indicates to the pedestrian what direction the vehicle is moving in. This can be very useful particularly around blind corners or trailers. Includes mounting bracket and straps for easy installation.

Specifications:

- Voltage: 12-60V
- Rating: CE
- Power: 3 x 3 Watt

Red Arrow Light also available.

- Arrow Blue Light
ARROWBLU-E..... **\$119⁹⁵**
- Arrow Red Light
ARROWRED-E..... **\$119⁹⁵**
- Magnetic Mount Option
MAGNET-E..... **\$8⁵⁰**



Checklist Caddy *Daily Operator Checklist*



SKID STEER LOADER



OVERHEAD CRANE/JIB CRANE



ELECTRIC STACKER



AERIAL WORK PLATFORM



ELECTRIC COUNTERBALANCE



PROPANE COUNTERBALANCE



NARROW AISLE



ELECTRIC PALLET

ITEM	DESCRIPTION	PRICE
Checklist Caddy (1 caddy, 1 checklist book)		
SCADD(E)-E	Electric Counterbalance	\$29.95
SCADD(CB)-E	Propane Counterbalance	\$29.95
SCADD(N)-E	Narrow Aisle	\$29.95
SCADD(P)-E	Pallet Truck	\$29.95
SCADD(A)-E	Aerial Lift Platform	\$29.95
SCADD(CR)-E	Overhead Crane/Jib Crane	\$29.95
SCADD(SS)-E	Skid Steer Loader	\$29.95
SCADD(ES)-E	Electric Stacker	\$29.95
Refill Pack (4 checklist books)		
RCADD(E)-E	Electric Counterbalance	\$45.95
RCADD(CB)-E	Propane Counterbalance	\$45.95
RCADD(N)-E	Narrow Aisle	\$45.95
RCADD(P)-E	Pallet Truck	\$45.95
RCADD(A)-E	Aerial Platform/Scissor Lift	\$45.95
RCADD(CR)-E	Overhead Crane/Jib Crane	\$45.95
RCADD(SS)-E	Skid Steer Loader	\$45.95
RCADD(ES)-E	Electric Stacker	\$45.95
ELOG(C)-E	Checklist Case Only	\$18.00

Make sure your lift trucks are safe to operate and prevent costly damage due to lack of mandatory inspection.

Includes:

- One Caddy 4 1/2" x 7" polyethylene envelope with two-way tape for easy mounting
- One coil pen
- One checklist pad with 75 inspection carbonless copy sheets

Lift Truck Log *The most complete Lift Truck recording system on the market!*

2-3 YEAR SUPPLY



Sample checklist 624 events per log



ITEM	DESCRIPTION	PRICE
LOG(CB)-E	Propane Counterbalance	\$49.95
LOG(E)-E	Electric Counterbalance	\$49.95
LOG(N)-E	Electric Narrow Aisle (reach & order picker)	\$49.95
LOG(P)-E	Electric Pallet Truck	\$49.95
Replacement Log Books		
RLOG(CB)-E	Propane Counterbalance Replacement Log Book	\$29.95
RLOG(E)-E	Electric Counterbalance Replacement Log Book	\$29.95
RLOG(N)-E	Electric Narrow Aisle Replacement Log Book	\$29.95
RLOG(P)-E	Electric Pallet Truck Replacement Log Book	\$29.95
Log Case Only		
ELOG(L)-E	Plastic Log Case Only 5"W x 8"L	\$18.00

Kit includes: Log, plastic case, lock-out tag and pull-strap. All in one box that easily attaches to any lift truck!

Complete with:

- Daily Check Lists x 624
- Repair Request Forms x 24
- Accident Report Forms x 4
- Near-miss Report Forms x 4
- Lock-out Tag (required if truck unsafe to operate)
- PM Tracking History x 36 Events (know when to service each truck)



NOTE: Regulation states that a lift truck be inspected before the beginning of each shift and a record be kept on file. The Lift Truck Log is a complete system that ensures the operator completes this important task. The Log is a highly visible case that mounts anywhere on the lift truck. A guaranteed way to ensure everyone does their safety inspections.

* Shipping included to most major cities, surcharges may apply to Quebec & Atlantic Canada. Prices are subject to change without notice.

For updated pricing or to place your order online visit: www.liftow.com

SAFETY ACCESSORIES



NEW!

Start-Manager Operator Access Control Systems

Control who has access to your forklifts and machinery with Start-Manager's dual function access control devices. All models can be activated with a 4-digit key code or 125 kHz proximity card or key-fob. These rugged units are weather proof, dust proof and vandal proof, and are built for the toughest industrial applications. The SM201 and SM301 units feature a daily operator safety check to be completed at the start of each shift. The SM301 unit includes an integrated Wi-Fi transceiver to allow for web-based data tracking for all trucks equipped with this model.



Start-Manager Model #SM101
Dual Function Vehicle Access Control

Features:

- 16-key stainless steel keypad
- Indestructible rubberized nylon housing
- Storage for up to 250 4-digit key codes
- Storage for up to 100 proximity card numbers
- Easy to program and remove codes or cards
- Last Operator search feature (for accident ID)
- Includes vehicle start and stop buttons
- 12-48V built-in voltage converter
- Includes (2) pre-programmed key-fobs
- 1 year warranty

Start-Manager Dual Function Access Control

SM101-A **\$430⁰⁰**



Start-Manager Model #SM201
Vehicle Access Control with Daily Operator Safety Check - Manual

Includes all the features of the SM101 Model plus:

- OLED white on black graphic display
- Vehicle hour meter, ID number, date and time
- OSHA/MOL compliant daily safety check feature
- Vehicle will not start until safety check is completed
- After a failed safety, choose whether or not the vehicle can start
- Manual operator sign off (no WiFi or network capability)
- Information collected: Vehicle number, current hours, operator number, time safety check was started, time check was completed, all failed checks

Start-Manager Dual Access Control with Daily Safety Check - Manual

SM201-A **\$570⁰⁰**



Start-Manager Model #SM301
Vehicle Access Control with Daily Operator Safety Check - Wireless

Includes all the features of the SM201 Model plus:

- OLED white on black graphic display
- Vehicle hour meter, ID number, date and time
- OSHA/MOL compliant daily safety check feature
- Vehicle will not start until safety check is completed
- After a failed safety, choose whether or not the vehicle can start
- Information can be easily retrieved via your existing WiFi network
- Information is collected: Vehicle number, current hours, operator number, time safety check was started, time check was completed, all failed checks

Start-Manager Dual Access Control with Daily Safety Check - Wireless

SM301-A **\$685⁰⁰**

Start-Manager Extra Options

ITEM	DESCRIPTION	PRICE
SMKEYFOB-A	Start-Manager 125 kHz Programmable Keyfob	\$16.00
SMBRACKET1-A	Start-Manager Compact Footprint Mounting Bracket - Standard Mount	\$40.00
SMCLD-A	Start-Manager Cold Storage Package	\$100.00



Start-Manager Programmable Keyfob



Start-Manager Mounting Bracket



Ergo Back-up Handle

Reduce back strain with the Ergo Back-up Handle. Operators who are required to travel frequently in reverse often grab the overhead guard. This is a dangerous practice and has resulted in serious injuries.

- Eases back stress when turning around
- Fits any lift truck
- Installs in minutes
- Keeps operator's hand inside the operator compartment
- Optional horn switch allows operator to keep left hand on wheel

BUPH-1-D \$49⁹⁵

**Back-Up Handle with Horn Button
BUPH-2-D \$64⁹⁵**

**Back-Up Handle with Built-In Horn Unit
BUPH-3-D \$89⁹⁵**



Anti-Blind Spot Dome Mirror

Lift truck operators need to know what is going on all around the lift truck. This mirror gives a complete 180° view allowing the operator to give a quick safety check before they travel in reverse. Installs on any lift truck in seconds with 3M two-sided tape.

Also available with a durable magnetic arm to attach to any metal surface.



**9" Dome Mirror with Adhesive
DOME-1-D..... \$54⁹⁵**



** Made of acrylic*

**9" Dome Mirror with Magnet Arm Mount
DOMEM-1-D..... \$74⁹⁵**

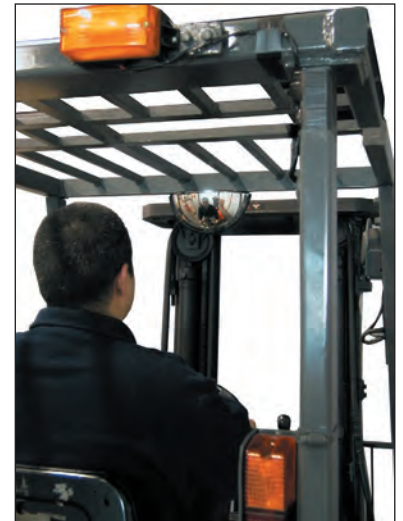

Mega Mirror

The mega mirror can mount on the overhead guard in seconds using the magnetic arm attachment. Provides a wide angle view of the operator's surroundings for safety and ideal for travelling in reverse.



Dimensions:
17-3/4"W X 3-1/4"H



** Made of acrylic*

**Mega Mirror with Magnetic Arm Mount
MEGAM-D \$74⁹⁵**

**Mega Mirror for 45° Overhead Guards
MEGAM45-D \$84⁹⁵**

Side-View Mirror

The side-view mirror can mount anywhere in the operator's compartment in seconds using the magnetic arm attachment. Provides a side-view of the operator's surroundings for safety.

Dimensions: 4-1/2"W X 8"H

**Side-View Mirror with Magnetic Arm Mount
SIDEM-D..... \$74⁹⁵**

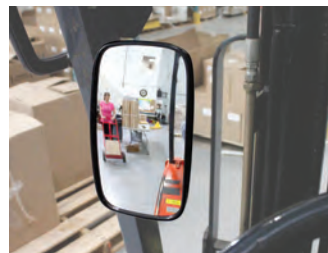

** Made of acrylic*

** Shipping included to most major cities, surcharges may apply to Quebec & Atlantic Canada. Prices are subject to change without notice.*

For updated pricing or to place your order online visit: www.liftow.com

SAFETY ACCESSORIES

Safe-Tilt Fork Angle Indicator

The Safe-Tilt easily mounts on the lift truck mast telling you the exact position of the forks, from park, to level, to travel. The Safe-Tilt also comes with sticker labels to specify additional tilt angles. With easy installation, easy calibration and operation, the Safe-Tilt is a must have for any tilt mast lift truck operator. Installs in less than 5 minutes without any tools.

SAFETLT-B **\$169⁹⁵**

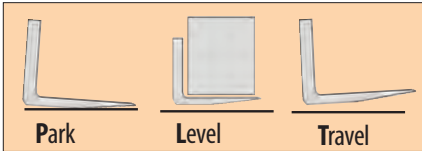

Attaches to any counterbalance forklift mast in just minutes.

Accu-Tilt Fork Tilt Level Indicator

The Accu-Tilt shows the operator the level of the forks at all times thereby reducing potential damage by piercing product or racking and increasing productivity by eliminating the guess work. Easy to install and for the operator to understand. It pays for itself in a manner of weeks. Installs in 2 minutes without any tools on any counterbalance lift truck.

- Reduce product damage
- Reduce rack damage
- Reduce pallet damage
- Increase productivity
- Decrease training time for new operators

ACCUTILT-B **\$179⁹⁵**



Accu-Tilt with Accu-Height
ACCUTILT-H-B **\$194⁹⁵**



Front View
This is the display the operator sees when looking through the mast.



Accu-Height Fork Height Indicator

The higher the lift, the harder it is to judge the correct height of the forks. Accu-Height is a simple sticker set that allows the operator to quickly know the right height of the forks at various rack levels. No more guessing if the forks are at the right height. Once the stickers are in place, the operator can quickly go to the right height. It only takes 15 minutes to install.

* Accu-Height is to be used with Accu-Tilt or Safe-Tilt

ACCUHEIGHT-E **\$24⁹⁵**



Correct fork height for entry and exit of pallet
By matching the indicator sticker with the color marker, the correct fork height is obtained to enter the pallet safety.

**THE FORKLIFT
EVEL-LITE**

NEW!

The Forklift Level-Lite

The main cause of product, rack and equipment damage is forks tilted at the wrong angle. If the forks are not level, drivers can spear product from inside or above the pallet opening, bend or push over racking, and splinter pallets. Take control of these issues with the all-new Level-Lite!

The Level-Lite Features:

- Under 1 minute to set up and install
- Accurate within 0.25 of one degree
- Uses standard "D" batteries
- Adapts to bent or uneven forks
- Not permanently fixed to mast
- Turns on/off automatically (motion activated)
- Engineered and made in the USA

The Level-Lite Benefits:

- No tools, wiring or mechanic needed
- 12 - 18 month average life (1600 operating hours)
- LED Indicators, Effective in all lighting conditions
- No on/off switch. Preserves battery life
- Rust proof and durable. Works outside in wet weather
- Box Dimensions: 2.5" x 2.5" x 6.5"
- Box Weight (with batteries) 1lb. 10 oz

Counterbalance Unit



**Level-Lite For Counterbalance
LEVELLITE-B \$375⁰⁰**

Reach Truck Unit



**Level-Lite For Reach Trucks
LEVELLITE-R-B \$499⁰⁰**

**LASER-GUIDE
FORK GUIDANCE SYSTEM**

Laser-Guide Fork Guidance System

Increase warehouse safety and productivity while reducing product damage with the Laser-Guide Fork Guidance System. The Laser-Guide is equipped with an adjustable, fan-shaped laser beam that projects out from the forks indicating the exact fork position.

- Turns on only when movement of the forks is detected to prolong charging intervals
- Includes lithium-ion battery with 110 Volt charger include
- Lasts approximately 1 – 3 months on a single charge
- Easily mounts to the carriage between the forks using an adjustable slider
- Available for Class 2 and Class 3 lift truck carriages
- Installs in minutes

Laser-Guide for Class 2 Carriage

LASERG2-A \$599⁰⁰

Laser-Guide for Class 3 Carriage

LASERG3-A \$599⁰⁰



**Shipping included to most major cities, surcharges may apply to Quebec & Atlantic Canada. Prices are subject to change without notice.*

For updated pricing or to place your order online visit: www.liftow.com

SAFETY ACCESSORIES

Multi-Use Lock-Out Box *Prevent use of unsafe equipment*

The Equipment Lock-Out Box is a lock-out and tag-out system that locks-out and tags-out your lift truck or other material handling equipment until repairs are made. This minimizes workplace injury by preventing the use of unsafe and malfunctioning facility equipment, water and gas outlets. The Lock-Out Box can also be used to lock-out/tag-out devices such as forklift batteries connectors, propane cylinders valves etc. The Lock-Out Box comes complete with lock-out box, lock-out tags, straps, lock and key. A simple solution to important employee safety!



Size: 6.5" L x 3.5" W x 2.5" D

**LOCK-OUT BOX
LOCKBOX-E \$39⁹⁵**

LOCKBOX-S-E (Same key) \$39⁹⁵



Forklift Battery Connectors



110-220-550 Volt AC Plugs



Forklift Propane Connectors



12 Volt DC Starter Batteries



Cylinders



Valves

Lock-Out Tags



Set of 25 Lock-Out Tags comes complete with 25 straps. Each tag is perforated so the bottom can be removed and adhesive double sided tape allows it to be attached to work orders.

Size: 6" x 2-7/8"



**LOCK-OUT TAGS (Box of 25)
TAG25-E \$45⁹⁵**

SB Connector Lockbox



- Lockout Device for SB, SBX, and DIN Connectors
- Made of durable polypropylene
- Fits 50, 175, and 350 amp connectors
- Has two padlock positions for OSHA lock-out/tag-out programs
- Instructions molded into cover in three languages - English, Spanish, and French

Size: 10.25" L x 4" W x 2.25" D

SBLB-D \$59⁹⁵

Atrium Full Forklift Enclosure

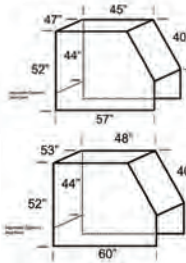

- Durable vinyl plastic
- Maintains operator visibility
- Cold crack resistance of -10° F
- Great for windy conditions
- Securable with velcro straps for easy installation
- Fits almost any counterbalance lift truck
- Prevents cold air from entering operator compartment

Standard (up to 6,000 lbs)
ATR-1-D **\$295⁰⁰**

Large (6,000 -12,000 lbs)
ATR-2-D **\$315⁰⁰**

Forkshield Overhead Guard Rain Shields

This easy to install rain guard will protect your operators from rain or snow.

- Attaches in seconds
- Universal for forklift, utility and security carts
- SUPERCLEAR material
- Impact resistant vinyl
- Size: 40" L x 45.5" W



**INSTALL ON
TOP, FRONT
OR BACK**

FSD01-D **\$99⁹⁵**

Solar Cap Canopy Protection

- No more squinting while transporting an overhead load
- Get more coverage with a see through visor
- Stay shaded from direct sun-light
- Made from durable anti-glare material
- Size: 52.5" L x 46" W



SC1-D **\$99⁹⁵**

ClearCap™ A clear solution to a common problem!

Designed to divert rain and small particulates away from the operator.

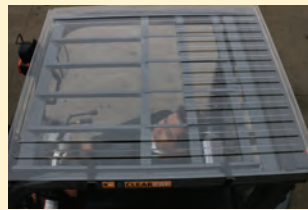

Since 1999, ClearCap™ has been providing rugged and well designed roof covers for current and late model lift trucks. Made of high impact, non-yellowing polycarbonate plastic, ClearCap™ provides relief from rain, snow, dust and sunlight for operators.



ClearCap™ features a unique dome design that diverts rain and small particulates away from the operator. Channels and gutters eliminate cascading water. This alternative to shrink-wrap, plywood, and cardboard provides greater operator comfort and safety.



Easy to Install, Reasonably Priced: ClearCap™ is quick and easy to install. No drilling or tapping is required; eliminating expensive shop time. Provide us with your overhead guard dimensions or lift truck model and we'll help you find a ClearCap™ that fits your forklift.

Four slotted holes and cam lock nylon straps allow for a simple, secure and tool-free installation in seconds.

ClearCaps™. OSHA standard 1917.43 (e)(1) (ii): clearly states that "Overhead guards shall not obstruct the operator's view."

Clear Model

Model	DESCRIPTION	PRICE
CC1000-B	35"W x 43.5"L	\$425.00
CC1001-B	37"W x 43.5"L	\$425.00
CC1002-B	39"W x 43.5"L	\$425.00
CC1006-B	39"W x 52"L	\$595.00
CC1012-B	39"W x 38.5"L	\$425.00
CC1017-B	50.5"W x 45"L	\$595.00
CC1018-B	53.25"W x 45"L	\$595.00
CC1013-B	31"W x 38.5"L	\$425.00
CC1003-B	31"W x 43.5"L	\$425.00
CC1015-B	33"W x 43.5"L	\$425.00
CC1008-B	35"W x 38.5"L	\$425.00
CC1009-B	36"W x 38.5"L	\$425.00
CC1007-B	42"W x 45.5"L	\$595.00
CC1010-B	45"W x 38.5"L	\$595.00
CC1004-B	45.5"W x 43.5"L	\$595.00
CC1005-B	44.5"W x 51.5"L	\$595.00
CC1011-B	47"W x 38.5"L	\$595.00
CC1019-B	48.25"W x 45"L	\$595.00
CC1016-B	42"W x 42"L	\$595.00

With Tinted UV Protection

Model	DESCRIPTION	PRICE
CC1000-T-B	35"W x 43.5"L	\$425.00
CC1001-T-B	37"W x 43.5"L	\$425.00
CC1002-T-B	39"W x 43.5"L	\$425.00
CC1006-T-B	39"W x 52"L	\$595.00
CC1012-T-B	39"W x 38.5"L	\$425.00
CC1017-T-B	50.5"W x 45"L	\$595.00
CC1018-T-B	53.25"W x 45"L	\$595.00
CC1013-T-B	31"W x 38.5"L	\$425.00
CC1003-T-B	31"W x 43.4"L	\$425.00
CC1015-T-B	33"W x 43.5"L	\$425.00
CC1008-T-B	35"W x 38.5"L	\$425.00
CC1009-T-B	36"W x 38.5"L	\$425.00
CC1007-T-B	42"W x 45.5"L	\$595.00
CC1010-T-B	45"W x 38.5"L	\$595.00
CC1004-T-B	45.5"W x 43.5"L	\$595.00
CC1005-T-B	44.5"W x 51.5"L	\$595.00
CC1011-T-B	47"W x 38.5"L	\$595.00
CC1019-T-B	48.25"W x 45"L	\$595.00
CC1016-T-B	42"W x 42"L	\$595.00

*Shipping included

*Shipping included to most major cities, surcharges may apply to Quebec & Atlantic Canada. Prices are subject to change without notice.

For updated pricing or to place your order online visit: www.liftow.com

SAFETY ACCESSORIES

The Backbone™ for Reach Trucks and Stand-Up Counterbalance Trucks

The Backbone™ is a safety device for reach trucks and stand-up counterbalanced trucks to protect operators against accidental rear-ward collisions with racking systems that may cause serious injury without reducing overhead guard protective capability. The Backbone™ is installed on a reach truck by simply clamping to the overhead guard from the top and bolting to the reach truck frame at the bottom by drilling small holes. Additional padding is strapped onto the back of the unit for operator comfort.

Features:

- Easy to install. Attaches in minutes.
- Minimum machine downtime and installation costs.
- Provides enhanced operator safety. Addresses the underride hazard around racking components.
- Provides greater operator control of the reach truck. Reduces the risk of objects striking the operator causing loss of control.

The Backbone™ is the **ONLY** fully tested safety bar on the market to meet both ASME & ANSI Industrial Standards.

BACKBONE-B **\$745⁰⁰**

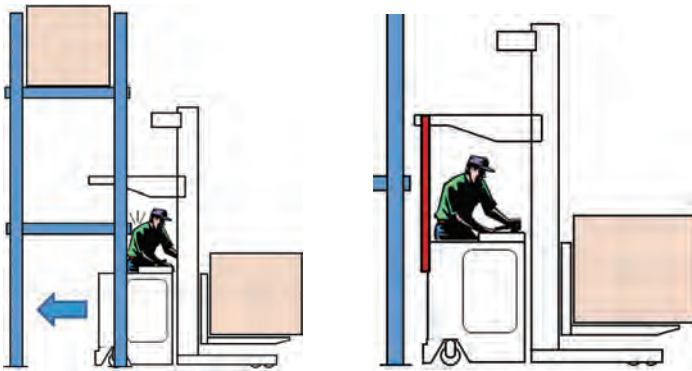

Lift Truck Safety Stickers

Reduce the chance of accidents by reminding the operator and pedestrians simple safety rules that protect them from injury or death. These stickers are UV coated so they will last for years and are perfect for any industrial setting. All stickers seen are included.



Lift Truck Safety Stickers (set of 16)
STCK-D **\$16⁹⁵**

These safety decals are a constant reminder to operators of the most common safety violations in the workplace.



Forklift Safety Signs

Keep your pedestrians and lift truck operators aware of potential hazards with these highly visible signs. Made of durable polyethylene plastic and perfect for the warehouse. Water resistant.

ITEM	DESCRIPTION	PRICE
SHRN-D	Caution, Stop Sound Horn	\$19.95
SPED-D	Caution Pedestrian Traffic	\$19.95
SFKL-D	Caution Forklift Traffic	\$19.95
SPROP-D	No Smoking Propane Changing	\$19.95
SBAT-D	No Smoking Battery Changing	\$19.95
SSEC-D	Caution Secure Trailer	\$19.95
SCHC-D	Caution Chock Wheels	\$19.95
SSTP-D	Stop Sign	\$24.95

Stop sign 18"



Safety Signs 10" x 14"



Code-Red Forklift Detection System

The Code-Red is a wireless collision avoidance system that offers a simple, inexpensive solution to reducing accidents in the workplace.



Features:

- Proximity Tag easily installed on any 12-24V forklift or industrial vehicle
- Proximity Detector detects presence of tagged forklift around corners to flash warning lights
- Detector easily mounts on racks, aiseways, walls or any area with high forklift traffic
- 20 – 40 foot programmable detector range and powered with standard 120VAC adaptor
- Detector includes (2) water-resistant LED lights measuring 9 1/2" x 1" x 5/8"
- Forklift Tag draws 150 mA at 12 – 24VDC
- Forklift Tag is shockproof, waterproof and IP68 rated
- Eliminates the need for workers to wear tags
- Works non-line-of-sight; around corners with no blind spots or coverage gaps

Code-Red Forklift Tag

CODERED-TAG-B **\$595⁰⁰**

Code-Red Detector With Warning Lights

CODERED-LITE-B **\$745⁰⁰**



Proximity Forklift Tag
mounts on any forklift



Proximity Detector With Warning Lights
mounts in any area where pedestrians need to be alerted of oncoming forklifts



LOOK-OUT™ Collision/Pedestrian Awareness System

- Avoid deadly and costly forklift collisions
- 100,000 hours lamp life
- Indoor, outdoor and cooler applications
- Adjustable sensors can detect moving objects 32 feet away

Blind intersections are a safety hazard for both forklifts and pedestrians. Over 40% of all forklift accidents involve pedestrians who often do not survive the incident. LOOK-OUT™ is a warning light device that uses motion sensors to warn oncoming traffic that there is a possible danger around blind corners.



Lets pedestrians and forklift operators know if someone is just around the corner with the New LOOK-OUT™

ITEM	DESCRIPTION	PRICE
LOOKOUT-2-B	Look-Out 2-Way Collision/Pedestrian Warning System	\$1,285.00
LOOKOUT-3-CM-B	Look-Out 3-Way Pedestrian Warning System - Ceiling Mount	\$1,535.00
LOOKOUT-3-RM-B	Look-Out 3-Way Pedestrian Warning System - Rack Mount	\$1,330.00
LOOKOUT-4-B	Look-Out 4-Way Collision/Pedestrian Warning System	\$1,740.00
OPTIONS		
TRANSFORMER-B	Optional Internal Universal Transformer for Conduit Installations	\$105.00
RSCABLE-20-B	Remote Sensor Cable 20' with Wall or Rack Bracket	\$80.00
RSCABLE-30-B	Remote Sensor Cable 30' with Wall or Rack Bracket	\$90.00
RSCABLE-40-B	Remote Sensor Cable 40' with Wall or Rack Bracket	\$105.00
ALARM-B	Optional Audible Alarm	\$135.00
BURSTRED-B	Optional Red Burst of Light Under Look-Out	\$260.00



LOOK-OUT™ 4-Way warning light can monitor traffic from 4 different directions.

**Shipping included*

**Shipping included to most major cities, surcharges may apply to Quebec & Atlantic Canada. Prices are subject to change without notice.*

For updated pricing or to place your order online visit: www.liftow.com

SAFETY ACCESSORIES



The Eagle-Eye is the first reinforced all-in-one forklift camera system. The Eagle-Eye is a durable, metal encased forklift camera system that is IP67 rated for dust and water protection. The Eagle-Eye is also a fully wireless camera system, so no unnecessary cables are needed between the camera and the monitor. The Eagle-Eye comes complete with 9" LCD monitor, 40-hour battery pack, camera, key fob switch and carriage mount bracket.

Eagle-Eye Features And Benefits:

- No unnecessary external wiring, all components are hidden away inside of the Eagle-Eye
- All vital components are protected by a steel casing
- Camera is IP67 rated for dust and water protection
- Monitor can be installed on any 12 - 48V forklift
- Switch function turns camera off after 5 minutes of inactivity, saving the life of the battery by 3-5 times longer
- All components can be charged within the casing or removed from the velcro for quick replacement
- Easy Installation and operation

Eagle-Eye Specifications:

- LCD Monitor Size: 9"
- Power Supply: 12 - 48V
- Power Consumption: Maximum 6W
- Operating Temperature: -4 F to 155 F RH 90%
- Warranty: 1 Year

Eagle-Eye Wireless Camera System

EAGLEEYE-B **\$995⁰⁰**

Additional Eagle-Eye Battery Pack

EEBAT-B..... **\$125⁰⁰**

The key fob allows the operator to only use the Eagle-Eye when needed. Monitor view automatically turns off after 5 mins of inactivity.



White Noise Back Up Alarms



- Warning signal is more directional and perceived to dissipate quicker than a pure tone alarm
- Emits sound at multiple frequencies attenuated above 4000Hz
- Sealed in epoxy for protection against dust, moisture and vibration
- Solution to potential noise pollution created by back up alarms in populated work areas
- Smart alarm model 77-97 db automatically adjusts sound at 5 db louder than surrounding noise
- Voltage: 12/24V (DC-DC converter required for 36V or 48V lift trucks)
- Operating temperature range: -40F to +185F
- Warranty: 2 years
- Conforms to SAE J994, CE rated



WNA97-B Model



WNSA7797-B Model

ITEM	DESCRIPTION	PRICE
WNA87-B	White Noise Alarm 87 db Multi Frequency, 12/24V	\$175.00
WNA97-B	White Noise Alarm 97 db Multi Frequency, 12/24V	\$225.00
WNSA7797-B	White Noise Smart Alarm 77 - 97 db Multi Frequency, 12/24V	\$315.00

* Shipping included to most major cities, surcharges may apply to Quebec & Atlantic Canada. Prices are subject to change without notice.

Safe-View Wireless Camera System

The Safe-View Wireless Camera System is an excellent tool to give the operator a variety of different views around the lift truck. The Safe-View is extremely easy to install and operate and can be used in the front, back or anywhere around the lift truck where visibility is limited.

Features:

- 7 inch or 9 inch LCD Monitor with 120° degree view angle camera
- Exceptionally clear picture
- Digital wireless system with built-in transmitters in the camera and display
- Automatic pairing capability with no interference from any other cameras
- Night Vision technology so you can see clearly in low light or dark conditions
- Recording capability with the use of an SD card
- 7 inch or 9 inch display accommodates up to 4 cameras
- Built with water and impact resistant housing
- Can be mounted anywhere on the forklift
- Easy Installation and operation

Specifications

- LCD Monitor Size: 7 inch or 9 inch
- Power Supply: 12 - 48V
- Power Consumption: Maximum 6W
- Transmitting Distance: Approximately 100 feet
- Operating Temperature: -4° F to 155° F RH 90%
- Warranty: 1 Year

The Safe-View Kit Includes: LCD Monitor (7 in. or 9 in.), *New!* Rechargeable Battery (21 hrs), Wireless Camera

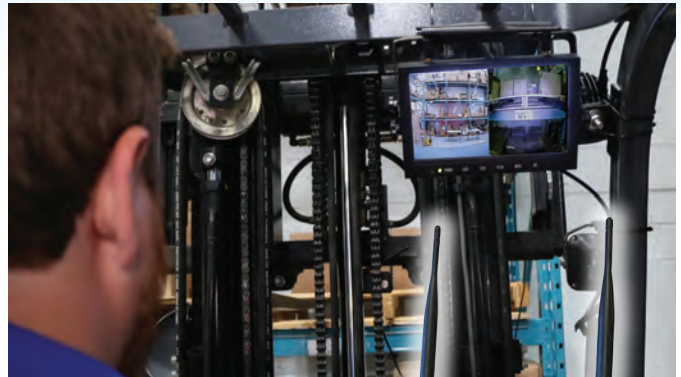

Available Options:



Safe-View Camera Switch turns the camera off after 5 mins of inactivity to save battery life



The Safe-View Camera Bracket With Bumper only available for class 2 carriages

ITEM	DESCRIPTION	PRICE
SAFEVIEW-B	Safe-View Wireless Camera System with 7 in Display	\$545.00
SAFEVIEW-9-B	Safe-View Wireless Camera System with 9 in Display	\$595.00
OPTIONS		
SVCAM-B	Extra Wireless Camera	\$165.00
SVBP-21-B	Extra Rechargeable Battery Pack	\$140.00
SVBRACKET-B	Camera Bracket With Bumper (Class 2 Carriages Only)	\$130.00
SVSWITCH-B	Camera Switch Option	\$50.00
SVCABLEREEL-B	Camera Cable Reel	\$545.00

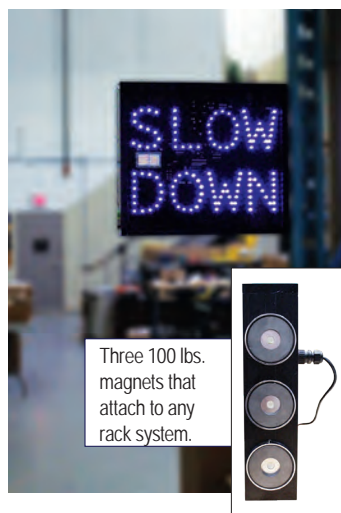

Three 100 lbs. magnets that attach to any rack system.

Safe-Speed Forklift Speed Alert Radar System



When forklift operators travel too fast in a high pedestrian traffic area, safety is in jeopardy. Safe-Speed is a radar detection system that alerts the operator to "SLOW DOWN" when they have exceeded the safe speed limit of a particular area. The Safe-Speed has been specifically designed for industrial equipment as it can detect traffic movement as low as 3 mph. An optional 12 volt flashing light or warning buzzer can also be installed (buzzer included).

- Speed Range: 3 mph (4 kph) to 120 mph (199 kph). Set by dip settings up to 30 mph or 50 kph
- Accuracy: +/- 1.5 kph
- Driver Feed Back Sign Housing: Weatherproof 370x420x90 mm 14.5" x 16.5" x 3.5"
- LED Display Characters: SLOW DOWN, 4" (100 mm) high Super Bright white LEDs
- Weight: 3 kg or 6.6 lbs
- Power: 110 volts
- Display Brightness: Auto adjusts to light conditions
- Sensor Range: 160 feet (50 m)
- Beam Width: 30/40 degrees
- Output allows for a light or buzzer to be installed (buzzer included, light not included)

SAFESPEED-B **\$1,795⁰⁰**

*Shipping included to most major cities, surcharges may apply to Quebec & Atlantic Canada. Prices are subject to change without notice.

For updated pricing or to place your order online visit: www.liftow.com

FACILITY PROTECTION

Column Protectors

Affordable protection for warehouse and factory columns and beams. These HDPE protectors fit 6", 8", 10" and 12" round and square supports. Two halves attach with easy-to-install straps.



Narrow Column Protector
Fits 4"- 6" Columns
Size: 13" x 13" x 42"



ITEM	SIZE (INCHES)	PRICE
1706-B	24" x 24" x 42" (6" Columns)	\$435.00
1708-B	24" x 24" x 42" (8" Columns)	\$435.00
1710-B	24" x 24" x 42" (10" Columns)	\$435.00
1712-B	24" x 24" x 42" (12" Columns)	\$435.00

Narrow Column Protector
1704-C.....**\$275⁰⁰**

Corner Protectors



HDPE Corner Protectors deflect the impact, helping to protect plant areas prone to damage by fork truck, hand truck, or personnel traffic.



Easily install on overhead door frames, H-frame racking, factory corners, use horizontally as rack guards or on loading docks. Sold in pairs.

Corner Protectors 21" pair
1720-C.....**\$140⁰⁰**

Corner Protectors 42" pair
1725-C.....**\$215⁰⁰**

Overhead Door Track Protector



Protect overhead door tracks from accidental impact and reduce maintenance costs.

- 45° flange adds strength, protects from side impact
- 7-gauge steel construction, powder coated safety yellow for high visibility
- ¼" foot plate drilled with slotted holes for 3 ½" anchors
- Wall flange drilled with slotted holes for three ¾" anchors
- Available in 24", 36" and 48" tall sections

SIZE	ORIENTATION *LOOKING FROM INSIDE TO OUTSIDE*	PART #	PRICE (EA)
24"	RIGHT	60-5090	\$90.00
	LEFT	60-5091	
36"	RIGHT	60-5092	\$105.00
	LEFT	60-5093	
48"	RIGHT	60-5094	\$115.00
	LEFT	60-5095	

Poly Fork Cushion - Load Protectors

- Cushioned non-slip surface over forks prevents costly damage during loading and unloading and keeps cargo securely positioned
- Engineered polyurethane mold provides remarkable durability and long service life
- Easy to install lock & pin style
- Sold in pairs

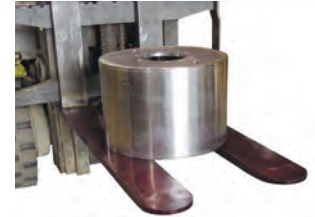

PROTECTIVE BUFFER

The Superior Fork Cushion/ Load Protector provides a cushioned surface between cargo and steel lift truck forks eliminating costly damage experienced during the loading and unloading process.

NON-SLIP SURFACE
Cargo remains securely positioned while in transit.

REINFORCED HEEL
An additional fiberglass mesh is implanted in the heel to provide strength and prevent tear out.



PREMIUM POLYURETHANE
Molded from Superior Cushothane® polyurethane, the STR Fork Cushion/ Load Protector is engineered to provide remarkable durability and unmatched service life.

OEM ATTACHMENT
Designed to exact OEM specifications.

EASY TO INSTALL
The Superior Fork Cushion / Load Protector easily slides over standard lift truck forks and remains secure with provided mounting hardware.

ITEM	SIZE (INCHES)	PRICE
EFF04-B	4" x 42"	\$700.00
EFF05-B	4" x 48"	\$720.00
EFF23-B	4" x 60"	\$730.00
EFF07-B	5" x 42"	\$760.00
EFF08-B	5" x 48"	\$800.00
EFF13-B	5" x 60"	\$920.00
EFF09-B	6" x 48"	\$810.00
EFF10-B	6" x 54"	\$830.00
EFF11-B	6" x 60"	\$850.00

Shipping included!*

Structural Rack Guards

Economical way to protect against damage to pallet racking and wall corners. Constructed of 6" or 8" structural steel "C" channel. Available with or without a rubber bumper. Easy to install to concrete surface. Four mounting holes for maximum stability. Safety yellow powder coat finish. Installation hardware sold separately.



MODEL	OVERALL HEIGHT	USABLE OPENING
G6-12-A	12.25"	4-9/16" X 3-11/16"
G6-18-A	18.25"	4-9/16" X 3-11/16"
G6-24-A	24.25"	4-9/16" X 3-11/16"
G6-36-A	36.25"	4-9/16" X 3-11/16"
AS-125-4PK-A	CONCRETE ANCHOR BOLTS (4) 1/2" X 5"	

Structural Rack Guard with Rubber Bumpers



MODEL	OVERALL HEIGHT	USABLE OPENING
G6-12-B-A	12.25"	4-9/16" x 2-7/8"
G6-18-B-A	18.25"	4-9/16" x 2-7/8"
G6-24-B-A	24.25"	4-9/16" x 2-7/8"
G6-36-B-A	36.25"	4-9/16" x 2-7/8"
AS-125-4PK-A	CONCRETE ANCHOR BOLTS (4) 1/2" X 5"	

Call For Pricing. Quantity discounts available.

Safe-Bump Forklift Bumpers

Specifically designed for forklifts, these bumpers reduce damage in many applications. Safe-Bump attaches with two 100 lb magnets and (VHB) two way tape.

- Size: 18" L x 4" W x 1.5" D
- Magnets: two 100 lb magnets
- Each bumper includes 2 magnets, two way tape and fork brackets.

Safe-Bump Forklift Bumper (Yellow)

SAFEBUMP-Y-E **\$75⁰⁰**

Safe-Bump Forklift Bumper (Black)

SAFEBUMP-B-E **\$75⁰⁰**

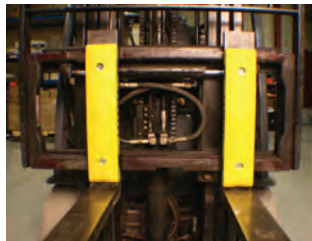

Safe-Bump attaches to 4" and 5" forks in seconds.



Safe-Bump is only 1.5" thick and protects product from damage.



Safe-Bump protects both the truck and anything the truck hits.



Safe-Bump can bend 900 to wrap around corners for maximum protection.



Safe-Bump can be applied almost anywhere protection is required.

Traffic Vest



High-visibility mesh 5-point tear-away traffic vest with Velcro closure. Reflective side stripes with Velcro adjustments.

8501-C **\$19⁹⁵**

Pallet Dawg Forklift Carriage Bumper

Features & Benefits:

- Reduces pallet damage by redirecting a forklift's impact to center block of the pallet
- Low profile impact bumper reduces product damage by avoiding contact with product that overhangs the front of the pallet
- Installed and can be removed in minutes with a socket wrench
- Compatible with any Class II forklift carriage
- Includes spacer plate to ensure a tight fit to forklift carriage
- High impact resistant nylon material
- Weighs only 7 lbs

PALDAWG-B **\$195⁰⁰**



Front view



Side view



* Shipping included to most major cities, surcharges may apply to Quebec & Atlantic Canada. Prices are subject to change without notice.

For updated pricing or to place your order online visit: www.liftow.com

FACILITY PROTECTION

Portable Safety Zone Barrier System



Quickly create a safe and complete visual barrier zone in virtually any indoor application. The Portable Safety Zone is easy to transport and is simple to set up or take down. The slim design allows for easy storage and accessibility. The optional LED Light Package creates a clear awareness of the Portable Safety Zone location in low light conditions.

Features:

- 100' of Safety Orange Fencing
- Easy to Use
- Fence Locking System
- Fits Through 30" Doorways
- Includes 4 Posts, 4 Rubber Base Pads & 4 Magnetic Fence Clips
- Light Weight and Easy to Transport
- Safety Orange Powder Coated Steel Construction



Portable Safety Zone Barrier System
70-6030-C **\$1,395⁰⁰**

Optional LED Light Package
70-6036-C **\$195⁰⁰**



Fork-Kushions

The Fork-Kushions offer a resilient yet durable solution by equipping a forklift truck with specially engineered polyurethane bumpers that are mounted to the upright of the fork. These highly engineered bumpers provide cushioning protection from marring, denting and other forms of damage. The unique structure offers excellent wear properties and vibration deadening without compromising the load capacity of the lift truck. Available for 4", 5" & 6" wide forks; mounting bracket measures 24" in length. Sold in sets including mounting brackets with adhesive and a pair of Fork-Kushions.



Ultra Soft Black Kushion



ITEM	MATERIAL	FORK WIDTH	PRICE
KPF-3410-SET-A	ULTRA SOFT BLACK	4"	\$540.00
KPF-3510-SET-A	ULTRA SOFT BLACK	5"	\$600.00
KPF-3420-SET-A	SOFT RED	4"	\$560.00
KPF-3520-SET-A	SOFT RED	5"	\$630.00
KPF-3440-SET-A	GENERAL PURPOSE YELLOW	4"	\$640.00
KPF-3540-SET-A	GENERAL PURPOSE YELLOW	5"	\$740.00
KPFN-5447-SET-A	CUT RESISTANT	4"	\$780.00
KPFN-5547-SET-A	CUT RESISTANT	5"	\$870.00
KP-5447-SET-A	MAXIMUM IMPACT	4"	\$680.00
KP-5547-SET-A	MAXIMUM IMPACT	5"	\$770.00

Shipping included!*

* Shipping included to most major cities, surcharges may apply to Quebec & Atlantic Canada. Prices are subject to change without notice.

All-Krete Concrete Floor Patch

All-Krete is our multi-use, easy-to-use concrete repair product designed for one-step permanent concrete repair. All-Krete quickly repairs pot-holes, joints, cracks and does not require any special preparation work or priming. An All-Krete applied pathway can be opened to all forms of traffic within one hour (even in sub-zero environments), avoiding expensive shutdowns.

10-44-R-D **\$345⁰⁰**

- Use on dry or damp floors
- Excellent on expansion joints
- From 12" deep to feather-edging at 1/16"
- Eliminates costly shutdown time
- Permanent concrete repair
- Comes in 50 lb. pail, covers 60 sq. ft.
- Cures at room temp. in 15 minutes
- Cures BELOW ZERO in 1 hour
- Won't shrink or peel back
- No heat systems or lamps required



Star Flex A Permanent Expansion Joint and Crack Compound

STAR-FLEX is a unique and complete expansion joint repair material designed for use in low temperature areas or anywhere a quick set is desired. STAR-FLEX cures to a high strength, resilient and long lasting seal in just 60 minutes.



- Repairs expansion joints and slip joints
- Requires NO heat lamps or propane torches
- May be used as a crack filler
- Cure time of 30 minutes at 750°F.
- Shelf life approximately 1 year. For extended shelf life, store at temperatures below 800°F and keep liquid resin securely closed when not in use.
- Clean-up with lacquer thinner.

11-19-RH-C **\$315⁰⁰**

Non-Skid Floor Coating

The slip-proof coating for concrete, masonry, metal and all other surfaces prevents slips, slides and falls.



- Excellent sure footing even in wet areas, stairways, loading docks, catwalks, shower rooms
- Resistant to alkali, detergents, acids, brake fluid, etc.
- Grey color available only
- Apply to wood, concrete, steel, stone, etc.

20-33C **\$185⁰⁰**

Warehouse Mirrors



Interior Convex

- 100+ Degree angle of view
- Ball & swivel plate attached directly to mirror for lightness and economy
- Complete with telescoping arm and mounting bracket

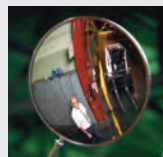

Exterior Convex

- 100+ Degree angle of view
- Ball & Swivel bolted to weatherproof back
- Mirror has weatherproof metal frame
- Complete with telescoping arm and mounting bracket



Full Dome Mirror

- For four-way intersections
- Comes complete with chains & hooks for hanging (T-bar clips available on selected drop ceilings)
- Edges protected with steel-reinforced, black bumper



Half Dome Mirror

- For "T" intersections
- Should be fastened to wall or ceiling
- Edges have steel-reinforced, black protective bumper

ITEM	DIAMETER	PRICE
C12-B	12" Interior Convex Mirror	\$65.00
C18-B	18" Interior Convex Mirror	\$85.00
C126-B	26" Interior Convex Mirror	\$110.00
C130-B	30" Interior Convex Mirror	\$150.00
C136-B	36" Interior Convex Mirror	\$175.00

ITEM	DIAMETER	PRICE
CE12-B	12" Exterior Convex Mirror	\$75.00
CE18-B	18" Exterior Convex Mirror	\$95.00
CE26-B	26" Exterior Convex Mirror	\$140.00
CE30-B	30" Exterior Convex Mirror	\$175.00
CE36-B	36" Exterior Convex Mirror	\$215.00

ITEM	DIAMETER	PRICE
FD18-B	18" 360 Degree Full Dome Mirror	\$125.00
FD24-B	26" 360 Degree Full Dome Mirror	\$180.00
FD33-B	33" 360 Degree Full Dome Mirror	\$285.00
FD48-B	48" 360 Degree Full Dome Mirror	\$470.00

ITEM	DIAMETER	PRICE
HD18-B	18" 180 Degree Half Dome Mirror	\$85.00
HD24-B	24" 180 Degree Half Dome Mirror	\$100.00
HD33-B	33" 180 Degree Half Dome Mirror	\$165.00
HD48-B	48" 180 Degree Half Dome Mirror	\$270.00

* Shipping included to most major cities, surcharges may apply to Quebec & Atlantic Canada. Prices are subject to change without notice.

For updated pricing or to place your order online visit: www.liftow.com

FACILITY PROTECTION

Rack Armor *Protects Heads While Retrieving Materials From Racks*

When workers retrieve materials or boxes from racking they often misjudge when it is safe to lift their heads. Rack Armor is always there to cushion the blow and prevents serious injury. Designed specifically for this application, Rack Armor is a cost effective way to protect workers from head injuries. Both inside surfaces have adhesive to attach to the rack beam. Includes cable ties to secure to rack. Outside dimensions: 1-1/4" W X 4" L.

Rack Armor (pair of 4 foot length pieces)
RACKARMOR-E (8 ft).....\$39⁹⁵

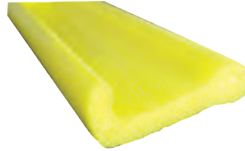

QuickMount Safety Barricade

The QuickMount Barricade features an 18' retractable safety belt enclosed in aluminum housing. The QuickMount back plate is designed to temporarily attach to warehouse shelving uprights blocking off warehouse aisles. This is ideal for when forklift operators want to block off an aisle while loading product onto racks or shelving. Installation hardware also included.

Safety Barricade 18 feet in length
3016-B\$155⁰⁰



Forklift Mount Option
917FM-B\$35⁰⁰



Electronic Code Switch *Prevent unauthorized use*

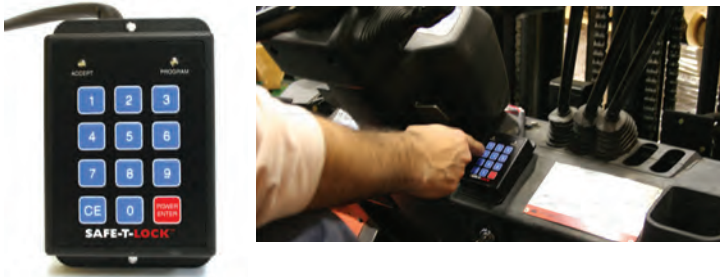

Keep unauthorized personnel from operating the lift truck.

The Electronic Code Switch can track up to 15 drivers, preventing unauthorized vehicle use. If an accident occurs and the vehicle is damaged, the last driver can easily be identified.

An alarm can also be programmed when maintenance is due.

ELECODE-C\$189⁰⁰

VOLTAGE INPUT

12-90VDC
 Correct voltage level must be set with DIP-switches on the rear of the ECS

OUTPUT

Relay contact rating: 6AMP continuous
 -10 (5 Sec.) for bigger loads, an external relay must be used

CURRENT USE

10mA when relay is not activated, less than 60mA in activated operation

Speed Saver *Automatic Speed Controller System*



Electronic Arm Actuator

Are your forklift operators driving too fast?

- Automatically controls the vehicle speed without reducing performance of hydraulics
- Installs on any gas, LPG or diesel powered vehicle including those with "fly by wire" throttles
- Engine RPM is only controlled when vehicle is traveling over the preset speed limit
- Has no effect on performance of new electronically controlled engine systems

Note: Please specify throttle type and truck model when ordering.

Speed Saver (Mechanical)
SS701-B\$2,495⁰⁰

Speed Saver (Fly By Wire)
SSEL701-B\$2,495⁰⁰





Air Suspension Model with options shown.

Primo Suspension Seats

The MSG 75/521 is a premium air seat, ergonomically designed to significantly improve the vibration characteristics of the forklift. Offers every driver the ultimate level of comfort.

- Quick and easy rapid intuitive weight adjustment with visual indicators from 45-170 kgs
- Suspension travel = 80 mm
- Fore/aft adjustment = 210 mm
- Narrow seat cushion = 470 mm
- Asymmetrical shape of backrest makes driving backwards more comfortable
- Mechanical lumbar support
- Three different slide rail mounting patterns 11.25", 12.63", 12.913"

ITEM	DESCRIPTION	PRICE
1245390-A	Black Vinyl 12 Volt (Air Suspension)	\$1,525.00
1245384-A	Matrix Cloth 12 Volt (Air Suspension)	\$1,575.00
1247709-A	Black Vinyl (Mechanical Suspension)	\$895.00
1247706-A	Matrix Cloth (Mechanical Suspension)	\$995.00
OPTIONS		
1079670-A	Armrest LH Tilt Up, Angle Adjustment	\$100.00
1079671-A	Armrest RH Tilt Up, Angle Adjustment	\$100.00
1079674-A	Duo Sensitive Retractable Seat Belt	\$160.00
1079667-A	Seat Switch (Included With Air Suspension)	\$150.00
142259-A	Document Box	\$60.00
1297720-A	170 Degree Right Swivel Option	\$420.00

Grammer B12 Seat

Do not let it's classic design deceive you. The Grammer B12 Seat is built with a rugged toughness and advanced, shock-absorbing materials so it can stand up to any job.



- Semi-suspension
- Suspension stroke up to 1.6 inches
- Weight adjustment range 110 - 265 lbs
- Fore/aft adjustment - accommodates all body sizes and types
- Operator presence switch, seat belt and armrest options

ITEM	DESCRIPTION	PRICE
1129306-A	Grammer B12 Black Vinyl Seat	\$340.00
1129307-A	Grammer B12 Black Vinyl Seat with Operator Presence Switch	\$420.00
1167745-A	Armrest Kit Option (Both Left & Right)	\$90.00
902131-A	Retractable Seat Belt Option	\$155.00

Anti-Vibration Seat Cushion

Hard shocks and vibrations can cause back stress when operating lift trucks. Shocks are absorbed by a dense foam pad that gives the operator added protection and comfort. Made of cambрил inner and vinyl outer covering with elastic velcro straps.

CUSH-C..... **\$139⁹⁵**



Full Back Rest

Back rests that reduce the risk of lower back strain. Select from the full back rest or the half back (available in black only).

FULBAC-C **\$139⁹⁵**



Half Back Rest

Mesh Seat Cushion with "air flow" for superior comfort and support.

HLFB-E **\$14⁹⁵**

* Shipping included to most major cities, surcharges may apply to Quebec & Atlantic Canada. Prices are subject to change without notice.

SEAT BELTS

Safe-Belt *The Most Comfortable Seat-Belt Your Operators Will Ever Wear*



- Simple Arc style design greatly improves operator comfort, flexibility and maneuverability while operating a forklift
- Spring Action Arm feature inhibits operator functionality ensuring operators are wearing their seat belt
- Highly visible yellow colored end shows supervisors seat belts are not being worn
- Easy to install and implement
- Complies with Regulations
- Available in both standard or with ignition switch



SAFEBELT-R-C **\$229⁰⁰**

With Ignition Switch
SAFEBELT-I-C **\$259⁰⁰**

Forklift Seat Belts

These retractable seat belts have bright orange webbing to ensure your operators are buckled up. All are 60" in length and conform to all safety specifications. The optional ignition isolation switch feature prevents the truck from starting unless the seat belt is fastened. Anti-Cinch seat belts allow for increased operator maneuverability.



Retractable Seat Belt
SEBELT-C **\$135⁰⁰**



Anti-Cinch Comfort Seat Belt
BBLP-1204-409-C **\$180⁰⁰**



Two Point Retractable Seat Belt with Ignition Isolation Switch
BBLP-1204-417-C **\$175⁰⁰**



Anti-Cinch Comfort Seat belt with Ignition Isolation Switch
1-2592-26-C **\$195⁰⁰**



Press & Release Retractable Seat Belt

The Press & Release Retractable Seat Belt allows the operator to manually adjust the tightness of the belt itself to a more comfortable level. To operate, the driver simply presses and holds the red button to release enough webbing to latch the tongue into the buckle while leaving ample slack to eliminate uncomfortable cinching into the abdomen. Available in black or orange webbing.

PNRBELT-BL-C **\$170⁰⁰**
PNRBELT-OR-C **\$170⁰⁰**



Big Boy Belt Dual Retractor Seat Belt

The Big Boy Dual Retractor Seat Belt is specifically designed for the larger lift truck operators who find the standard size seat belts too confining and uncomfortable. The Big Boy Belt features a 55" retractable belt on both the buckle side and receptacle side of the seat belt allowing for a total length of 110". Finally, there is a seat belt solution for the larger individual.

BIGBELT-C **\$150⁰⁰**

FORKLIFT ATTACHMENTS

Economical Portable Loading Platform Shipping included!*

The safest and quickest way for one person to load and unload cargo or equipment. Works great for locations without a loading dock. Optional handrail available. Features handrails on two sides, back mesh screen and chains.

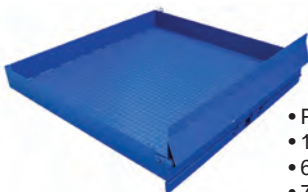

- Platform Size 54" x 54"
- 12" Long Beveled Lip
- 6" High Side Guards
- 7-1/2" x 2-1/2" Fork Pockets
- Capacity 2,000 lbs.
- (4) Tie Down Rings

FTLP-5454-B



FTLP-5454-HR-B

FTLP-5454-B . . . **\$2,130⁰⁰** Fork Truck Loading Platform with Options
 FTLP-5454-HR-B . . . **\$2,460⁰⁰**

Fork Truck Snow Plow Shipping included!*



Unique design attaches to fork truck forks. Pass through fork tubes keep weight back towards fork truck mast. Locking pins secure snow plow for forks for safety. Manual pivot mechanism for angled plowing on both sides. Floating pads allow for adjustment of plowing height.

SPB-N-72-A . . . **\$4,740⁰⁰**

OPTIONAL WEIGHT FOR BETTER PLOWING PERFORMANCE
 SPB-N-WT-A . . . **\$860⁰⁰**

Hoisting Hooks Shipping included!*

The Hoisting Hook transforms any fork truck into an overhead lifting hoist. Fork openings are located on 13" centers. Secured to the lift truck by means of a 48" long safety restraint and screw clamps. This Hoisting Hook unit includes a heavy-duty swivel hook with safety clip. Auto-Tension Hoisting Hook offers a unique design and adds tension as weight is added.

ITEM	DESCRIPTION	POCKET SIZE	CAPACITY	PRICE
S-FORK-4/6-RL-B	Single Fork Attachment Rigid	6" x 2 1/4"	4,000 lbs.	\$365.00
S-FORK-4/6-SL-B	Single Fork Attachment Swivel	6" x 2 1/4"	4,000 lbs.	\$380.00
S-FORK-4-AT-B	Single Fork Attachment Auto-Tension	6" x 2 1/4"	4,000 lbs.	\$480.00
D-FORK-4-RL-B	Double Fork Attachment Rigid	6 3/4" x 2 1/2"	4,000 lbs.	\$565.00
D-FORK-4-SL-B	Double Fork Attachment Swivel	6 3/4" x 2 1/2"	4,000 lbs.	\$585.00
D-FORK-10-SL-B	Double Fork Attachment Swivel	6 3/4" x 3 1/2"	10,000 lbs.	\$865.00

Single Fork



Double Fork



Auto Tension Fork



Pallet Dumper/Retainer Shipping included!*

This chain-actuated pallet dumper/retainer has finger-like retainers to hold the pallet in place while dumping. This unit is fork mounted, has a 2,000 lb. capacity and is held in place by a safety chain.



PAL-D/R-B . . . **\$1,525⁰⁰**

Fork Mounted Hook Base Shipping included!*

The Fork Mounted Hook Base Attachment converts a lift truck into a tow truck for moving trailers and other portable equipment. This simple design slides onto the forks and secures into place with safety pins. Welded steel construction with powder coat blue finish. Optional pintle hook, tow balls, and lifting hooks available. Bolt on design.



Fits up to a 5" wide x 2" thick fork

ITEM	FORK LENGTH	LENGTH TO CENTER OF BALL	CAPACITY	PRICE
HOOK-BASE-32-B	36"	32-3/8"	4,000 lbs.	\$1,215.00
HOOK-BASE-38-B	42"	38-3/8"	4,000 lbs.	\$1,255.00
HOOK-BASE-44-B	48"	44-3/8"	4,000 lbs.	\$1,290.00

Options:

ITEM	BALL DIA.	SHANK DIA.	CAPACITY	PRICE
BALL-178-B	1 7/8"	1"	2,000 lbs.	\$15.00
BALL-200-B	2"	1"	5,000 lbs.	\$16.00
BALL-2516-B	2 5/16"	1"	5,000 lbs.	\$17.00



ITEM	BALL DIA.	VERTICAL CAPACITY	TRAILER CAPACITY	PRICE
PINTLE-8	1 3/4"	2,000 lbs.	5,000 lbs.	\$165.00

ITEM	DESCRIPTION	SIZE	CAPACITY	PRICE
HOOK-4-B	Hook w/ Shackle	10" x 3.5"	4,000 lbs.	\$160.00
HOOK-6-B	Hook w/ Shackle	10" x 4.75"	6,000 lbs.	\$185.00
HOOK-10-B	Hook w/ Shackle	14.5" x 6.5"	10,000 lbs.	\$340.00

Fork Mounted Trash Can Dumper Shipping included!*

Save time and reduce work-related injuries caused by lifting and dumping heavy waste containers. This innovative product allows a fork truck driver to lift and dump refuse containers, weighing up to 1,000 lb., without ever leaving the seat of the fork truck!



Only for use with 64 gallon trash can, model TH-64, or approved equal. Fork pockets are 2-1/4" high by 7-1/4" wide usable. Steel construction for years of dependable use.

FM-T-DUMPA . . . **\$2,200⁰⁰**

64 Gallon Trash Can - Grey
 TH-64-GY-A . . . **\$185⁰⁰**

* Shipping included to most major cities, surcharges may apply to Quebec & Atlantic Canada. Prices are subject to change without notice.

FORKLIFT ATTACHMENTS

Fork Extensions

- Handles large and odd shaped loads
- Tilt slide-on design
- Fits up to 2" thick forks
- Fork extension not to exceed 50% of existing fork length
- Sold in pairs

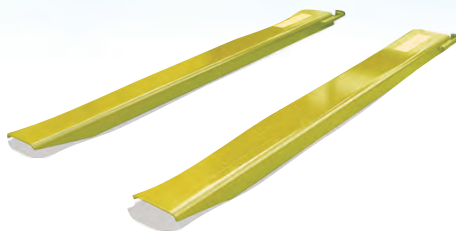

ITEM	FORK WIDTH	MAX INSIDE	WIDE LENGTH	MAX THICKNESS	PRICE
8448-A	4"	4.5"	48"	2"	\$420.00
8454-A	4"	4.5"	54"	2"	\$450.00
8460-A	4"	4.5"	60"	2"	\$470.00
8463-A	4"	4.5"	63"	2"	\$475.00
8466-A	4"	4.5"	66"	2"	\$485.00
8472-A	4"	4.5"	72"	2"	\$500.00
8484-A	4"	4.5"	84"	2"	\$625.00
8496-A	4"	4.5"	96"	2"	\$740.00
8548-A	5"	5.5"	48"	2"	\$500.00
8554-A	5"	5.5"	54"	2"	\$510.00
8560-A	5"	5.5"	60"	2"	\$525.00
8563-A	5"	5.5"	63"	2"	\$535.00
8566-A	5"	5.5"	66"	2"	\$545.00
8572-A	5"	5.5"	72"	2"	\$550.00
8584-A	5"	5.5"	84"	2"	\$710.00
8596-A	5"	5.5"	96"	2"	\$920.00
8648-A	6"	6.5"	48"	2"	\$515.00
8654-A	6"	6.5"	54"	2"	\$540.00
8660-A	6"	6.5"	60"	2"	\$560.00
8672-A	6"	6.5"	72"	2"	\$595.00
8684-A	6"	6.5"	84"	2"	\$845.00
8696-A	6"	6.5"	96"	2"	\$995.00

Rounded or Triangular Fork Extensions

- Holds large rolls of material
- Round or triangular shaped extensions
- Sold in pairs



ITEM	WIDTH	MAX INSIDE	WIDTH LENGTH	MAX THICKNESS	PRICE
FE-4-54-T-B	4"	5"	54"	2"	\$1,240.00
FE-4-63-T-B	4"	5"	63"	2"	\$1,295.00
FE-5-54-T-B	5"	6"	54"	2"	\$1,260.00
FE-5-63-T-B	5"	6"	63"	2"	\$1,320.00
FE-4-54-R-B	4"	5"	54"	2"	\$1,240.00
FE-4-63-R-B	4"	5"	63"	2"	\$1,295.00
FE-5-54-R-B	5"	6"	54"	2"	\$1,260.00
FE-5-63-R-B	5"	6"	63"	2"	\$1,320.00

Shipping included! *

Fork Extensions Storage Rack

Install or remove fork extensions without lifting, pushing or getting off the fork truck.



Drive in so tips of forks are over elevated bar.

Lower forks until fork nests in channel in base of rack.

Back fork truck out of fork restraining straps.

FORK-R-54-B **\$1,070⁰⁰** Shipping included! *

Coil Rams/Lifters

The Coil Lifter is used to easily maneuver many types of coiled material. The Coil Lifter is available in both class II carriage mount and fork mount models.



Carriage Mounted series CCM



Fork Mounted series CCF

MODEL	LENGTH	POLE DIA.	WEIGHT (LB)	CAPACITY (LB)	PRICE
Fork Mounted - Inverted					
CCF-36-4-B	36"	4.5"	275	3,000	\$1,415.00
CCF-48-4-B	48"	4.5"	290	3,000	\$1,465.00
CCF-60-4-B	60"	4.5"	305	3,000	\$1,530.00
CCF-36-5-B	36"	5.5"	315	5,500	\$1,145.00
CCF-48-5-B	48"	5.5"	325	5,500	\$1,195.00
CCF-60-5-B	60"	5.5"	345	5,500	\$1,240.00
Carriage Mounted - Class II					
CCM-36-4-B	36"	4.5"	160	3,000	\$980.00
CCM-48-4-B	48"	4.5"	175	3,000	\$1,055.00
CCM-60-4-B	60"	4.5"	190	3,000	\$1,095.00
CCM-36-5-B	36"	5.5"	200	5,500	\$1,145.00
CCM-48-5-B	48"	5.5"	217	5,500	\$1,195.00
CCM-60-5-B	60"	5.5"	230	5,500	\$1,240.00

Shipping included! *

Carpet Poles and Rug Rams



Available in either carriage or fork mounted style. 2-3/4" diameter high strength, rotatable, replaceable pole has tapered tip. All units are made of steel construction and painted blue.

Fork Mounted Rug Rams feature 7 1/2" W x 2 1/2" H fork pockets on 24" centers. Safety chain is included to secure unit to fork truck.

ITEM	DESCRIPTION	LENGTH	DIAMETER	CAPACITY	PRICE
Fork Mounted Inverted					
CRP-108-B	Fork Mount-Inverted	108"	2.75"	2,500 lbs.	\$2,655.00
CRP-120-B	Fork Mount-Inverted	120"	2.75"	2,200 lbs.	\$3,015.00
CRP-144-B	Fork Mount-Inverted	144"	2.75"	1,800 lbs.	\$3,085.00
Fork Mounted					
CRF-108-B	Fork Mount	108"	2.75"	2,500 lbs.	\$2,565.00
CRF-120-B	Fork Mount	120"	2.75"	2,200 lbs.	\$2,960.00
CRF-144-B	Fork Mount	144"	2.75"	1,800 lbs.	\$3,055.00
Carriage Mounted - Class II					
CR-108-2-B	Fork Mount for Class II Trucks	108"	2.75"	2,500 lbs.	\$1,745.00
CR-120-2-B	Fork Mount for Class II Trucks	120"	2.75"	2,200 lbs.	\$1,785.00
CR-144-2-B	Fork Mount for Class II Trucks	144"	2.75"	1,800 lbs.	\$1,955.00
Carriage Mounted - Class III					
CR-108-3-B	Fork Mount for Class III Trucks	108"	2.75"	2,500 lbs.	\$1,765.00
CR-120-3-B	Fork Mount for Class III Trucks	120"	2.75"	2,200 lbs.	\$1,805.00
CR-144-3-B	Fork Mount for Class III Trucks	144"	2.75"	1,800 lbs.	\$1,975.00

Shipping included! *



67° Self-Dumping Hoppers with Bumper Release

- 67° tilt
- Hopper release bumper
- Automatically returns to locked position after dumping
- Capacities up to 5,500 lb., 3 cubic yards
- Powder coated finish
- Fork pockets measure: 7 1/2" wide by 2-1/2' high

Shipping included! *

All hoppers are available in the following colors. Call for pricing.

Item	VOLUME CUBIC YARD	CAPACITY	GAUGE OF STEEL	PRICE
D-200-LD-B	2	2,000 lbs.	12	\$2,455.00
D-300-LD-B	3	2,000 lbs.	12	\$3,455.00
D-200-MD-B	2	4,000 lbs.	10	\$2,555.00
D-300-MD-B	3	4,000 lbs.	10	\$3,620.00
D-33-HD-B	0.33	4,500 lbs.	7	\$1,815.00
D-50-HD-B	0.50	4,500 lbs.	7	\$1,915.00
D-75-HD-B	0.75	4,500 lbs.	7	\$2,045.00
D-100-HD-B	1.0	5,000 lbs.	7	\$2,390.00
D-150-HD-B	1.5	5,000 lbs.	7	\$2,640.00
D-200-HD-B	2.0	5,500 lbs.	7	\$2,910.00
D-250-HD-B	2.50	5,500 lbs.	7	\$3,280.00
D-300-HD-B	3.0	5,500 lbs.	7	\$3,790.00



GREEN



GREY



ORANGE



WHITE



YELLOW



GALVANIZED

* Shipping included to most major cities, surcharges may apply to Quebec & Atlantic Canada. Prices are subject to change without notice.

For updated pricing or to place your order online visit: www.liftow.com

FORKLIFT ATTACHMENTS

Econo Boom

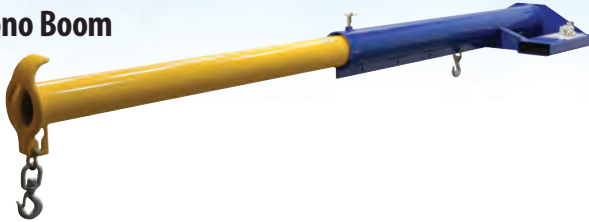

The Econo Boom telescopes extend from 80" to 144" extended. The telescopic section of the boom is secured in place with an infinitely adjustable locking screw. Fork pockets measure 7½" W x 2½" H on 24" centers. Overall size is 32" W x 11" H. Non-telescopic style also available.

ITEM	DESCRIPTION	PRICE
LM-EBT-4-24-B	Econo Boom Telescoping - 4,000 lb capacity	\$2,050.00
LM-EBNT-4-24-B	Econo Boom Non-Telescoping - 4,000 lb capacity	\$1,765.00

6,000 lb. and 8,000 lb. capacity upgrades available.



Orbiting Boom

The Orbit Boom has a convenient counterbalance system and drop lock pin which provides a quick and easy one-man operation and adjustment. This unit provides a horizontal reach to 12 feet. Six vertical adjustment positions add between 2½" and 8½" feet of working height.

The telescopic section is secured in place with a drop lock pin. Available in non-telescopic design.



ITEM	DESCRIPTION	PRICE
LM-OBT-4-24-B	Orbit Telescopic Boom - 4,000 lb capacity	\$3,065.00
LM-OBNT-4-24-B	Orbit Non-Telescopic Boom - 4,000 lb capacity	\$2,770.00

6,000 lb. and 8,000 lb. capacity upgrades available.



High Riser Boom

The High Riser Boom adds five feet of lifting height to any fork truck. The telescopic section of the boom is adjustable from 54" retracted to 78" extended. The overall height of the boom is 70" and the overall width is 32". The fork openings are 7½" wide x 2½" high on 24" centers. Available in non-telescopic design.



ITEM	DESCRIPTION	PRICE
LM-HRT-4-24-B	High Rise Telescopic Boom	\$3,890.00
LM-HRNT-4-24-B	High Rise Non-Telescopic Boom	\$2,775.00

6,000 lb. and 8,000 lb. capacity upgrades available.



Lift Master Boom

Unique performance, convenience and safety features are incorporated into the Lift Master Boom. Fabricated from structural steel with welding to meet A.W.S. It creates a rugged and durable boom that will provide long term service. A 36" chain secures the boom to the fork truck for safe operation. Each unit includes two lifting hooks.

ITEM	DESCRIPTION	PRICE
LM-1T-4-24-B	Lift Master Telescopic Boom	\$2,395.00
LM-1NT-4-24-B	Lift Master Non-Telescopic Boom	\$2,170.00

6,000 lb. and 8,000 lb. capacity upgrades available.



Shorty Lift Master Non-Telescopic Boom



Shorty Lift Master Telescopic Boom

Shorty Lift Master Booms

Short boom length is ideal for tight areas. Choose either telescoping or non-telescoping design. Includes built-in fork pockets and safety restraint. Steel construction with powder-coat blue finish.

ITEM	DESCRIPTION	OVERALL LENGTH	CAPACITY (LBS)	PRICE
LMS-EBT-46-4-B	Shorty Lift Master Telescopic Boom	55 1/4" to 93"	4,000	\$1,915.00
LMS-EBT-46-6-B	Shorty Lift Master Telescopic Boom	55 1/4" to 93"	6,000	\$2,440.00
LMS-EBT-46-8-B	Shorty Lift Master Telescopic Boom	53 7/8" to 90 7/8"	8,000	\$2,925.00
LMS-EBNT-40-4-B	Shorty Lift Master Non-Telescopic Boom	50.75"	4,000	\$1,665.00
LMS-EBNT-40-6-B	Shorty Lift Master Non-Telescopic Boom	50.75"	6,000	\$2,180.00
LMS-EBNT-40-8-B	Shorty Lift Master Non-Telescopic Boom	49 3/8"	8,000	\$2,655.00



DRUM HANDLING EQUIPMENT

Multi-Purpose Drum Lifter/Wrench



This simple three-arm design is for use with closed head 30 and 55 gallon plastic, steel and fiber drums with a top lip. Each removable arm also functions as a wrench for use on drum plugs, faucets and ring bolts. Capacity 800 lbs.

**Multi-Purpose Drum Lifter
PDL-800-M-A..... \$390⁰⁰**

Shipping included!*

Horizontal Drum Carrier

Designed to load and unload open or closed head drums horizontally in racks. "T" handle locks secure cradle to the forks to maximize safety and productivity. Drum lock engages and disengages automatically as a function of the fork angle. Fork pockets measure 7-5/8" wide by 2-5/8" high.



**Horizontal Drum Carrier
HORIZ-70-A..... \$1,155⁰⁰**

Shipping included!*

Automatic Eagle Beak Drum Lifters

Choose single-drum or double-drum configuration. Includes safety restraint to secure unit to the fork truck. Welded steel construction. Powder coat finish. Fork pockets measure 7 5/8" wide x 2 9/16" high usable. A ratchet strap is supplied to secure the drum to the unit when traveling over rough terrain.



FMDL-1-A



FMDL-2-A

**Single Drum Lifter 1,000 lb. Capacity
FMDL-1-A..... \$1,950⁰⁰**

**Dual Drum Lifter 2,000 lb. Capacity
FMDL-2-A..... \$2,480⁰⁰**

Shipping included!*

Deluxe Combination Fork Mounted Drum Lifter

Deluxe Combination Fork Mounted Drum Lifter includes attachments to lift any type of drum; 30 and 55 gallon, steel, plastic, fiber and open or closed head drums. Includes single Eagle Beak™ unit and both bottom and top lip Poly Drum Lifters. Capacity will vary depending upon which attachment you are using. Fork pockets have an inside measurement of 7 1/2" wide by 2 1/2" high. Includes safety chain and T-locks for securing unit to fork truck. Welded steel construction. Powder coat finish.



**Deluxe Combination Fork Mounted Drum Lifter
DFDL-3-A..... \$2,595⁰⁰**

Shipping included!*

Fork Mounted Poly Drum Handlers

A top lip plastic drum lifter for use with 30 and 55-gallon plastic closed head drums. 7 1/2" wide x 2 1/2" high usable fork tubes on 20 1/2" centers. High drum attachment point for use with top lip at least 3/16" high. Will also work with steel and fiber drums.



**Bottom Drum Lifter 800 lb. Capacity
FPDL-8-L-A..... \$1,540⁰⁰**

**Top Drum Lifters 1,100 lb. Capacity
FPDL-11-H-A..... \$1,805⁰⁰**

Shipping included!*

Polyester Drum Slings

Polyester Drum Handling Slings are specifically designed for the efficient handling of 55 gallon, ribbed, metal drums. It can be used to lift open top drums, or even drums fitted with spigots or pumps.

The sling consists of a 3" bridle and a 2" circumferential tightening band. The lift bridle is permanently attached to the tightening band, thus eliminating the need to position the bridle for lifting.

The lift loop is attached to the circumferential tightening band. The unattached leg is free to be positioned for various drum diameters.

Working Load Limit: 1,000lbs

**Polyester Drum Slings
DS23-36-D..... \$159⁰⁰**



*Shipping included to most major cities, surcharges may apply to Quebec & Atlantic Canada. Prices are subject to change without notice.

For updated pricing or to place your order online visit: www.liftow.com

DRUM HANDLING EQUIPMENT

Drum Grippers 55 Gallon Only

 Shipping included!*

The Drum Gripper makes it easy to pick up one or two steel drums without leaving the seat of the fork truck. Simply slip the forks into the fork tubes and the Drum Gripper is ready to go. All models feature hinged folding design for storage. Welded steel construction. Powder coat finish.



DGS-55-D-A

DGD-55-D-A

ITEM	DESCRIPTION	CAPACITY	FORK POCKET SIZE (WXH)	PRICE
DGS-55-D-A	(1) 55 Gallon Steel Drum Gripper	1,500 lb	7-1/8"x2-1/16"	\$1,240.00
DGD-55-D-A	(2) 55 Gallon Steel Drum Gripper	2,000 lb	7-1/8"x2-5/16"	\$1,360.00

Drum Grippers 30 and 55 Gallon Steel Drums

 Shipping included!*

The Drum Gripper makes it easy to pick up one or two steel drums without leaving the seat of the fork truck. Simply slip the forks into the fork tubes and the Drum Gripper is ready to go. All models feature hinged folding design for storage. Models DGS-A and DGD-A feature adjustable-width arms for use with both 30-gallon and 55-gallon steel drums. Welded steel construction. Powder coat finish.



DGS-A-A

DGD-A-A

ITEM	DESCRIPTION	CAPACITY	FORK POCKET SIZE (WXH)	PRICE
DGS-A-A	One 30 or 55 Gallon Steel Drum	800 lb	7-5/8"x 1-7/8"	\$1,265.00
DGD-A-A	Two 30 or 55 Gallon Steel Drums	1,500 lb	7-5/8"x 1-7/8"	\$1,460.00

Economy Drum Positioner

 Shipping included!*

Drum Positioner is a unique design to manipulate drums without leaving the fork truck seat. Designed to lift 55-gallon steel and plastic drums from horizontal to the vertical position and vice versa using completely mechanical operation. Ideal for use with drum stands, pallets and racking. Suitable for loading drums into vehicles. Hinged tines lock automatically when lowered to ground in horizontal position. Fork pockets measure 5 1/2"W x 2"H usable.



ITEM	DESCRIPTION	CAPACITY	PRICE
VEDP-55-A	55 Gallon Steel Drums and Plastic Drums	800 lb.	\$1,515.00

Drum Positioner

 Shipping included!*

Allows fork truck driver to invert standing drums to the horizontal racking position and vice-versa. Positive latching system ensures safe handling of drums weighing up to 800 lbs. Slide the positioner extensions over the vertical drum. With the aid of the Drum Positioner rotate drum to horizontal position. Latching system will engage to allow horizontal positioning of drum. It's now ready to slide into the rack. Mechanical operation relies on fork truck to rotate and lift drums. Fork pockets measure 7 5/8"W x 2 9/16"H usable on 19 1/2" centers.

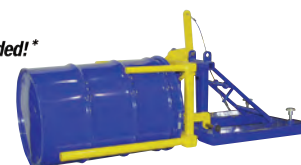

ITEM	DESCRIPTION	CAPACITY	PRICE
DRUM-P-30-A	For 30 gallon steel drums	800 lbs.	\$2,310.00
DRUM-P-55-A	For 55 gallon steel drums	800 lbs.	\$2,320.00

Manual Drum Carrier/Rotator

 Shipping included!*



This product allows you to easily transport and rotate 55 gallons steel drums using a fork truck. Drums are held securely in place by a durable chain locking system. Each unit is provided with a 15 foot long chain to allow the drum to be rotated up to 360° from the fork truck operator's seat. Fork pockets measure 7" wide by 2 3/4" high usable. Safety chain is used to secure unit to fork truck.

Drum Carrier/Rotator 800 lbs Capacity
DCR-205-8-A.....**\$1,745⁰⁰**

Drum Carrier/Rotator 1,500 lbs Capacity
DCR-205-15-A.....**\$1,990⁰⁰**

Fork Mounted DC Drum Carrier/Rotator

 Shipping included!*

DC powered fork truck mounted drum carrier and rotator, for use with 55-gallon steel drums only, 800 or 1,200 lbs. capacity, battery powered drum rotation for effortless dumping, includes battery, charger and hand held control on coil cord.

55 Gallon Steel, 800 lbs Capacity
DCR-205-8-DC-A.....**\$4,970⁰⁰**

55 Gallon Steel, 1,200 lbs Capacity
DCR-205-12-DC-A.....**\$5,305⁰⁰**



Aluminum Truck Dock Plate

- Durable lightweight, aluminum alloy
- Bevelled edges on top and bottom
- Non-slip tread surface
- Highly visible orange edges
- 10° arch at the top to allow board/plate to lie flat
- Steel legs fit between truck and board/plate to prevent movement during use
- Equipped with safety curbs to strengthen the board and prevent equipment run off

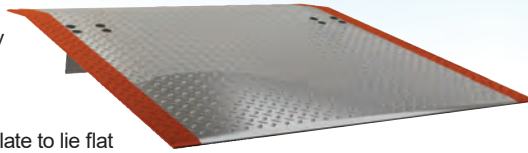

Fixed and Portable Poly Dock Plates

This new durable polyethylene dock plate is designed for use with two and four wheeled dollies, hand trucks, carts and pallet trucks. It has a 750 and 1,000 pound load capacity, beveled entry and exit edges, two carry handles, high visibility yellow, integrated guardrails, and powder coated steel legs. 36" L x 35" W x 5" H. Compliance: Meets OSHA 1910.30(a)

Portable Poly Dock Plate 750 lbs Capacity
1795-C **\$360⁰⁰**

Fixed Poly Dock Plate 1,000 lbs Capacity
1796-C **\$360⁰⁰**

Edge-O-Dock Leveler



- Easy installation to any loading dock with a steel dock edge
- Service range is 5" above dock level and 5" below dock level
- Mechanical units include leveler, bumpers and actuation bar
- Usable ramp length beyond face of dock bumpers is 12" on all models
- Field installation required by qualified personnel
- Beveled edges provide smooth transition

ITEM	DESCRIPTION	CAPACITY	PRICE
FM-2066-A	Mechanical 66" Width	20,000 lbs.	\$2,430.00
FM-2072-A	Mechanical 72" Width	20,000 lbs.	\$2,665.00
FM-2566-A	Mechanical 66" Width	25,000 lbs.	\$2,730.00
FM-2572-A	Mechanical 72" Width	25,000 lbs.	\$2,895.00

Shipping included!*



Glad Hand Lock

The Glad Hand Lock is applied to the emergency brake (red) connection of the trailer. This lock must be removed before the air line from the trailer can be connected and thereby release the emergency brakes on the trailer. An excellent way to dead-line a trailer.

Note: Locks can be keyed the same or individually.

GLAD003-D **\$49⁹⁵**

SIZE (WXL) INCHES	MAXIMUM HEIGHT DIFFERENCE INCHES	LIGHT DUTY			STANDARD DUTY			HEAVY DUTY		
		ITEM	AXLE LOAD	PRICE	ITEM	AXLE LOAD	PRICE	ITEM	AXLE LOAD	PRICE
36 X 48	7	AL3648-A	700	\$575.00	A3648-A	1,700	\$710.00	AHD3648-A	3,000	\$870.00
42 X 48	7	AL4248-A	800	\$630.00	A4248-A	2,000	\$790.00	AHD4248-A	3,500	\$975.00
48 X 24	3	AL4824-A	1,800	\$455.00	A4824-A	4,500	\$550.00	AHD4824-A	8,000	\$660.00
48 X 30	4	AL4830-A	1,450	\$515.00	A4830-A	3,600	\$625.00	AHD4830-A	6,400	\$765.00
48 X 36	5	AL4836-A	1,250	\$570.00	A4836-A	3,000	\$710.00	AHD4836-A	5,400	\$870.00
48 X 42	6	AL4842-A	1,050	\$630.00	A4842-A	2,600	\$785.00	AHD4842-A	4,600	\$975.00
48 X 48	7	AL4848-A	900	\$685.00	A4848-A	2,200	\$870.00	AHD4848-A	4,000	\$1,080.00
48 X 54	8	AL4854-A	760	\$745.00	A4854-A	1,700	\$945.00	AHD4854-A	3,300	\$1,190.00
48 X 60	9	AL4860-A	600	\$800.00	A4860-A	1,500	\$1,025.00	AHD4860-A	2,700	\$1,295.00
48 X 72	11	AL4872-A	400	\$915.00	A4872-A	1,100	\$1,185.00	AHD4872-A	2,000	\$1,610.00
60 X 24	3	AL6024-A	2,200	\$515.00	A6024-A	5,600	\$625.00	AHD6024-A	10,000	\$765.00
60 X 30	4	AL6030-A	1,800	\$585.00	A6030-A	4,200	\$725.00	AHD6030-A	8,000	\$895.00
60 X 36	5	AL6036-A	1,500	\$655.00	A6036-A	3,700	\$825.00	AHD6036-A	6,700	\$1,025.00
60 X 42	6	AL6042-A	1,300	\$725.00	A6042-A	3,200	\$925.00	AHD6042-A	5,800	\$1,155.00
60 X 48	7	AL6048-A	1,100	\$800.00	A6048-A	2,800	\$1,025.00	AHD6048-A	5,000	\$1,395.00
60 X 60	9	AL6060-A	880	\$940.00	A6060-A	2,200	\$1,330.00	AHD6060-A	3,800	\$1,660.00
72 X 24	3	AL7224-A	2,600	\$570.00	A7224-A	6,700	\$705.00	AHD7224-A	12,000	\$870.00
72 X 30	4	AL7230-A	1,950	\$655.00	A7230-A	5,400	\$825.00	AHD7230-A	9,500	\$1,130.00
72 X 36	5	AL7236-A	1,650	\$740.00	A7236-A	4,500	\$945.00	AHD7236-A	8,000	\$1,290.00
72 X 42	6	--	--	--	A7242-A	3,800	\$1,065.00	AHD7242-A	6,850	\$1,440.00

Aluminum Wheel Risers

For applications where the shipping/receiving dock is much higher than the truck floor or trailer bed. These wheel risers will raise the truck floor or trailer bed to dock level, and facilitate ease of loading and unloading.



HEIGHT (IN.)	OVERALL LENGTH	DECK LENGTH	ITEM	18" WIDE NET WT. PER PAIR (LBS.)	PRICE	ITEM	24" WIDE NET WT. PER PAIR (LBS.)	PRICE
6	42	24	AWR25-1845-6-A	102	\$1,360.00	AWR25-2445-6-A	124	\$1,620.00
8	52	24	AWR25-1852-8-A	122	\$1,500.00	AWR25-2452-8-A	150	\$1,855.00
10	59	24	AWR25-1859-10-A	150	\$1,800.00	AWR25-2459-10-A	178	\$2,105.00
12	66	24	AWR25-1866-12-A	180	\$2,015.00	AWR25-2466-12-A	210	\$2,385.00
6	57	36	AWR25-1857-6-A	133	\$1,690.00	AWR25-2457-6-A	164	\$2,060.00
8	64	36	AWR25-1864-8-A	157	\$1,860.00	AWR25-2464-8-A	194	\$2,325.00
10	71	36	AWR25-1871-10-A	189	\$2,190.00	AWR25-2471-10-A	226	\$2,550.00
12	78	36	AWR25-1878-12-A	222	\$2,415.00	AWR25-2478-12-A	263	\$2,870.00
6	69	48	AWR25-1869-6-A	164	\$1,930.00	AWR25-2469-6-A	204	\$2,340.00
8	76	48	AWR25-1876-8-A	192	\$2,205.00	AWR25-2476-8-A	238	\$2,690.00
10	83	48	AWR25-1883-10-A	228	\$2,460.00	AWR25-2483-10-A	274	\$2,995.00
12	90	48	AWR25-1890-12-A	264	\$2,820.00	AWR25-2490-12-A	316	\$3,290.00

NOTE: Due to volatile market, pricing on metal products is subject to change without notice

* Shipping included to most major cities, surcharges may apply to Quebec & Atlantic Canada. Prices are subject to change without notice.

For updated pricing or to place your order online visit: www.liftow.com

DOCK ACCESSORIES/ EQUIPMENT

Aluminum Truck Dock Board

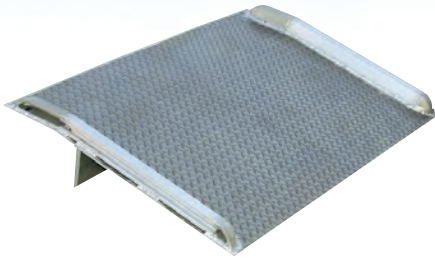

Dock Board Optional Parts

Forklift Handles
FLHL-A \$140⁰⁰

Forklift Handles recommended for dock boards weighing over 140 lbs / 63 kg.

Adjustable Span Locks
ASL-A \$260⁰⁰

Fixed Span Locks
FSL-A \$140⁰⁰

For counterbalanced forklift trucks, axle load is 90% of the total weight. For powered pallet trucks, axle load is 67% of the total weight.

4,000 - 10,000 LBS.					10,000 - 20,000 LBS.				
SIZE (WXL) INCHES	MAXIMUM HEIGHT DIFFERENCE INCHES	MODEL NUMBER	AXLE LOAD	PRICE	SIZE (WXL) INCHES	MAXIMUM HEIGHT DIFFERENCE INCHES	MODEL NUMBER	AXLE LOAD	PRICE
54 x 60	9	A4-5460-A	4,000	\$1,635.00	66 x 60	9	A10-6660-A	10,000	\$2,200.00
54 X 72	11	A4-5472-A	4,000	\$1,950.00	66 x 72	11	A10-6672-A	10,000	\$3,165.00
60 x 60	9	A4-6060-A	4,000	\$1,735.00	72 x 48	7	A10-7248-A	10,000	\$1,980.00
60 x 72	11	A4-6072-A	4,000	\$1,950.00	72 x 60	9	A10-7260-A	10,000	\$2,330.00
54 x 48	7	A6-5448-A	6,000	\$1,440.00	72 x 72	11	A10-7272-A	10,000	\$3,360.00
54 x 60	9	A6-5460-A	6,000	\$1,650.00	72 x 84	13	A10-7284-A	10,000	\$3,780.00
54 x 72	11	A6-5472-A	6,000	\$2,115.00	60 x 36	5	A12-6036-A	12,000	\$1,490.00
60 x 48	7	A6-6048-A	6,000	\$1,520.00	60 x 48	7	A12-6048-A	12,000	\$1,785.00
60 x 72	11	A6-6072-A	6,000	\$1,970.00	60 x 60	9	A12-6060-A	12,000	\$2,290.00
66 x 36	5	A6-6636-A	6,000	\$1,525.00	72 x 36	5	A12-7236-A	12,000	\$1,885.00
66 x 48	7	A6-6648-A	6,000	\$1,600.00	72 x 48	7	A12-7248-A	12,000	\$1,995.00
66 x 60	9	A6-6660-A	6,000	\$1,850.00	72 x 84	13	A12-7284-A	12,000	\$3,780.00
72 x 48	7	A6-7248-A	6,000	\$1,675.00	60 x 36	5	A14-6036-A	14,000	\$1,500.00
54 x 36	5	A8-5436-A	8,000	\$1,245.00	60 x 48	7	A14-6048-A	14,000	\$2,005.00
54 x 48	7	A8-5448-A	8,000	\$1,450.00	60 x 60	9	A14-6060-A	14,000	\$2,310.00
54 x 60	9	A8-5460-A	8,000	\$1,875.00	60 x 72	11	A14-6072-A	14,000	\$2,950.00
54 x 72	11	A8-5472-A	8,000	\$2,345.00	66 x 36	5	A14-6636-A	14,000	\$1,795.00
60 x 36	5	A8-6036-A	8,000	\$1,300.00	66 x 48	7	A14-6648-A	14,000	\$2,110.00
60 x 48	7	A8-6048-A	8,000	\$1,530.00	66 x 60	9	A14-6660-A	14,000	\$2,440.00
60 x 60	9	A8-6060-A	8,000	\$1,750.00	66 x 72	11	A14-6672-A	14,000	\$3,185.00
60 x 72	11	A8-6072-A	8,000	\$2,195.00	72 x 36	5	A14-7236-A	14,000	\$1,895.00
72 x 30	4	A8-7230-A	8,000	\$1,440.00	72 x 48	7	A14-7248-A	14,000	\$2,215.00
72 x 36	5	A8-7236-A	8,000	\$1,600.00	72 x 60	9	A14-7260-A	14,000	\$2,555.00
72 x 48	7	A8-7248-A	8,000	\$1,685.00	72 x 72	11	A14-7272-A	14,000	\$3,380.00
72 x 60	9	A8-7260-A	8,000	\$1,945.00	72 x 84	13	A14-7284-A	14,000	\$3,800.00
72 x 72	11	A8-7272-A	8,000	\$2,790.00	72 x 60	9	A16-7260-A	16,000	\$3,475.00
72 x 84	13	A8-7284-A	8,000	\$3,110.00	72 x 72	11	A16-7272-A	16,000	\$4,015.00
54 x 36	5	A10-5436-A	10,000	\$1,415.00	72 x 84	13	A16-7284-A	16,000	\$4,540.00
54 x 48	7	A10-5448-A	10,000	\$1,680.00	72 x 36	5	A18-7236-A	18,000	\$2,200.00
54 x 60	9	A10-5460-A	10,000	\$2,160.00	72 x 36	5	A20-7236-A	20,000	\$2,210.00
54 x 72	11	A10-5472-A	10,000	\$2,775.00	72 x 48	7	A20-7248-A	20,000	\$2,950.00
60 x 60	9	A10-6060-A	10,000	\$2,065.00	72 x 60	9	A20-7260-A	20,000	\$3,490.00
60 x 72	11	A10-6072-A	10,000	\$2,580.00	72 x 72	11	A20-7272-A	20,000	\$4,140.00
66 x 36	5	A10-6636-A	10,000	\$1,785.00	72 x 84	13	A20-7284-A	20,000	\$4,695.00
66 x 48	7	A10-6648-A	10,000	\$1,890.00	--	--	--	--	--

Trailer Stabilizing Jacks



Auto Stand

- 40,000 lb. lifting capacity
- Supports trailers up to 100,000 lb.
- 41" - 50.5" height range

60-5452-B **\$795⁰⁰**



Ratchet Top Stabilizer Jack

- 40,000 lb lifting capacity
- Supports trailers up to 100,000 lb.
- 41" - 50½" height range
- 2 jacks per trailer recommended

60-5453-B **\$395⁰⁰**

ONLY ONE STAND REQUIRED!

Pallet Pullers



TYPE	ITEM	DESCRIPTION	PULLING CAPACITY	JAW HEIGHT	JAW OPENING	PRICE
A	PAL-12-B	Single Scissor	5,000 lbs.	2¾"	7"	\$280.00
B	PAL-16-B	Single Scissor Heavy-duty	6,000 lbs.	2"	7"	\$300.00
C	PAL-14-B	Cam Action Design	5,000 lbs.	1½"	3"	\$310.00
D	PAL-21-B	Double Scissor	5,000 lbs.	2¾"	4"	\$300.00
E	PAL-LP-B	Double Scissor-Low Profile	5,000 lbs.	2"	3¼"	\$310.00
	PPC-20-B	20' OF ¼" Chain w/ Grab Hooks	6,000 lbs.	---	---	\$165.00
	PPC-40-B	40' OF ¼" Chain w/ Grab Hooks	6,000 lbs.	---	---	\$210.00

Shipping included!*

NOTE: Due to volatile market, pricing on metal products is subject to change without notice

* Shipping included to most major cities, surcharges may apply to Quebec & Atlantic Canada. Prices are subject to change without notice.

Liftow

Call to order: **1-866-Go Liftow (1-866-465-4386)**

DOCK ACCESSORIES/ EQUIPMENT

ECO Plastic Wheel Chock

- Bright yellow wheel chock easy to see when in use
- Light weight only 2 lbs
- Easy to use handle makes it easy to carry and pull out of tire
- Has 3 steel strips to grip pavement for ice and sand
- Dimensions: 18"L x 8"W x 9"H

Bright Yellow Chock



3 Steel Grip Bars

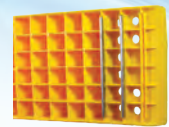

Chock Handle



ECOCHK-C **\$18⁰⁰**

Complete Wheel Chock System Models *Comes with Chock, Bracket, 15' chain and reverse caution chock sign*



Molded Rubber Wheel Chocks Pyramid with Eye Hook

- 8"W x 9"L x 6"H
- 8 lbs.

Chock 60-7204-C **\$25⁰⁰**
System 60-7204CS-C **\$125⁰⁰**



Steel Wheel Chocks IC-10 Formed Steel Ice Chock

- 8"W x 10½"L x 9¼"H
- 9 lbs.

Chock 60-7284-C **\$50⁰⁰**
System 60-7284CS-C **\$150⁰⁰**



Molded Rubber Wheel Chocks With Integral Handle

- 7¼"W x 9¾"L x 7¾"H
- 13 lbs.

Chock 60-7250-C **\$35⁰⁰**
System 60-7250CS-C **\$135⁰⁰**



Aluminum Wheel Chocks

- 7"W x 11½"L x 8"H
- 6 lbs.

Chock 60-7210-C **\$55⁰⁰**
System 60-7210CS-C **\$155⁰⁰**



Molded Rubber Wheel Chocks Solid Pyramid with U-Handle

- 8"W x 10"L x 5"H
- 12 lbs.

Chock 60-7206-C **\$40⁰⁰**
System 60-7206CS-C **\$145⁰⁰**

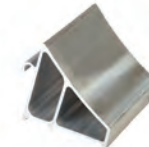

Aluminum Wheel Chocks

- 6"W x 6⅝"L x 6"H
- 3½ lbs.

Chock 60-7211-C **\$40⁰⁰**
System 60-7211CS-C **\$145⁰⁰**

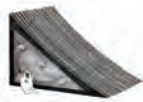

Laminated Rubber Wheel Chock

- Model 88-8
- 8"W x 8"L x 8"H
- 14 lbs.

Chock 60-7200-C **\$45⁰⁰**
System 60-7200CS-C **\$140⁰⁰**



Cast Ductile Iron Wheel Chock

- 8"W x 12"L x 9"H
- 28 lbs.

Chock 60-7280-C **\$70⁰⁰**
System 60-7280CS-C **\$160⁰⁰**



Orange Urethane Wheel Chock

- Model 811-11
- 11"W x 8"L x 8"H
- 4.5 lbs.
- Not recommended for ice

Chock 60-7208-C **\$60⁰⁰**
System 60-7208CS-C **\$155⁰⁰**



Cast Ductile Iron Wheel Chock

- 8½"W x 7¼"L x 8½"H
- 14 lbs.

Chock 60-7290-C **\$50⁰⁰**
System 60-7290CS-C **\$150⁰⁰**

15' Length Tie Back Chain
60-7238-C **\$35⁰⁰**



Wheel Chock Wall Bracket
60-7252-C **\$30⁰⁰**



Economical Wheel Chock Caution Sign
60-7242-C **\$30⁰⁰**



Reverse Image Wheel Chock Caution Sign
60-7243-C **\$35⁰⁰**

* Shipping included to most major cities, surcharges may apply to Quebec & Atlantic Canada. Prices are subject to change without notice.

For updated pricing or to place your order online visit: www.liftow.com

DOCK ACCESSORIES/ EQUIPMENT



CHAMELEON LED DOCK LIGHT

Chameleon LED Dock Light

Illuminate The Entire Trailer With Two Adjustable LED Lights!

Get a full spectrum view of your trailer with these new chameleon style LED lights! Just like the chameleon you'll be able to see in any direction!

- The 2 LED lights included can pivot and be adjusted in many different directions to completely illuminate your trailer
- 40 inch arm
- 110 volt A/C adapter plugs into wall for easy installation
- 50,000 hrs lifespan on each light
- 1500 Lumens each
- Low Profile Design prevents damage from lift truck impacts
- Impact Resistant
- CSA & U/L Listed Adapter
- Adjustable Lights prevent light blindness in operator's eyes
- IP67 Rated, Water Resistant and Dustproof

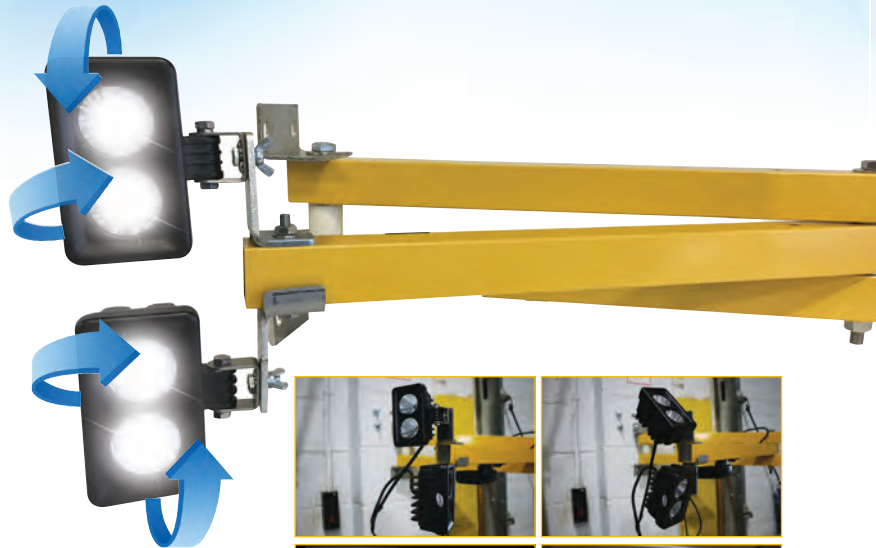

Before

After

Chameleon LED Dock Light
CHAMLITE-C **\$229⁰⁰**

Standard LED Dock Light

- 80% less energy than incandescent or halogen bulbs
- Achieves maximum light intensity instantly
- No fragile filament to break
- No shattered glass to sweep up
- Light is optimized for trailer illumination
- Ideal for use in food warehouses
- Voltage range for use world wide
- Voltage input: 100-240VAC, 50/60 Hz, Single Phase
- UL, cUL, CE certified and RoHs compliant
- Reach: 40" and 60" (1016mm and 1524mm)
- Shipping weight: 15 lbs
- **Warranty: 3 years**



Standard LED Dock Light - 40" Arm
60-5441-C **\$330⁰⁰**

Standard LED Dock Light - 60" Arm
60-5442-C **\$350⁰⁰**

Dock Traffic Lights



Sure-Lite Exterior

Sure-Lite Interior

TCS 3000 Sure-Lite

The Sure-Lite is an unrivaled, low cost alternative to maintain communication between truck drivers and loading dock attendants. The red and green LED lights are instantly understood as "Stop" and "Go", providing clear signals to dock attendants inside the building and truck drivers outside the building.

- Control entry to parking garages, loading dock areas and drive-thrus
- Parking lot entrances and exits or any high traffic areas
- Guide trucks backing into loading docks
- Warn workers and drivers of hazardous situations

PART #	DESCRIPTION	PRICE
60-5411-C	TCS-3000 Sure-Lite Exterior 12-24V Single Phase	\$215.00
60-5412-C	TCS-3000 Sure-Lite Interior 12-24V Single Phase	\$215.00

TCS 3000 Sure-Dock

Looking through their mirrors, truck drivers can safely center their truck and/or trailer in between the Sure-Dock. Docking maneuvers can be dangerous and costly when mistakes are made due to poor visibility. Sold individually.

Sure-Dock 12-24V Single Phase
60-5414-C **\$180⁰⁰**



Sure-Dock Lite

Lift-Rite General Purpose Pallet Truck



The Lift-Rite general purpose hand pallet truck is designed to meet the challenges of the modern material-handling environment. Uncompromised performance and reliability for maximum operator productivity is what this truck delivers. Whether your application is a warehouse, transport trailer, or factory, the Liftow pallet truck will prove to be a valuable tool for your business.

ITEM	DESCRIPTION	PRICE
LCR55270048-A	48"L x 27"W	\$705.00
LCR55270042-A	42"L x 27"W	\$705.00
LCR55270036-A	36"L x 27"W	\$705.00
LCR55205048-A	48"L x 20.5"W	\$705.00
LCR55205042-A	42"L x 20.5"W	\$705.00
LCR55205036-A	36"L x 20.5"W	\$705.00
LCS55270072-A	72"L x 27"W	\$1,465.00
LCS55205072-A	72"L x 20.5"W	\$1,540.00
LCS55270096-A	96"L x 27"W	\$1,885.00

Altra Lift Hand Pallet Truck

The Altra Lift Hand Pallet Truck is a budget conscious workhorse that keeps you on the move. It's designed with a durable adjustable Tubular push rod and self-lubricating bushing pivots that boost efficiency and minimize wear and tear.

Features:

- 5,500 lbs capacity
- 3" lowered height, 7.75" raised height
- 7" dia. polyurethane wheels with 3" dia. rollers
- Heavy duty frame constructed with high tensile steel
- Ergonomic tear drop handle with 3-way position lever
- Hydraulic pump with over-load bypass valve
- 1 year warranty on pump and frame

ITEM	DESCRIPTION	PRICE
A511AYE3-A	Altra Pallet Truck 5500 lbs 27" x 48"	\$395.00
A512AYE3-A	Altra Pallet Truck 5500 lbs 27" x 42"	\$395.00
A513AYE3-A	Altra Pallet Truck 5500 lbs 27" x 36"	\$395.00
A521AYE3-A	Altra Pallet Truck 5500 lbs 20.5" x 48"	\$395.00
A522AYE3-A	Altra Pallet Truck 5500 lbs 20.5" x 42"	\$395.00
A523AYE3-A	Altra Pallet Truck 5500 lbs 20.5" x 36"	\$395.00



Buy 6
or more units
\$325⁰⁰/ea

SideWinder Pallet Truck

Transport long loads down narrow aisles with this heavy duty Sidewinder Pallet Truck. This versatile pallet truck retains all the quality workmanship of a standard pallet truck, with the addition of lateral movement.



- Service Range: 3½" to 8"
- Fork Size: 27" x 48"
- Capacity: 3,000 lbs

SW-PJ-B..... **\$1,450⁰⁰**

Shipping included!*

All Terrain Pallet Truck *handles like a standard pallet truck!*

- 1,000 - 2,000 lb capacity (depending on load center)
- Inside straddle is 50" / outside straddle is 64"
- Pneumatic tires have sealed bearings for outside durability
- Adjustable fork width: 9½" to 26"
- Overall size: 64"W x 50" L x 51"H
- Net weight: 328 lbs

ALL-T-2-B..... **\$2,200⁰⁰**

Shipping included!*



* Shipping included to most major cities, surcharges may apply to Quebec & Atlantic Canada. Prices are subject to change without notice.

MATERIAL HANDLING

Manual Hydraulic Hand Pump Stackers

Manual Hydraulic Hand Pump Stackers are sturdy and compact to fit through standard doors. Forks are raised by manual hydraulic hand pump operation and released by a lever situated on the handle. 1" lift per handle pump. Two rigid and two swivel wheels standard.

ITEM	DESCRIPTION	CAPACITY	SERVICE RANGE	OVERALL SIZE (WXLXH)	PRICE
VHPS-2000-FF-A	Manual Hand Hydraulic	2,000 lbs.	3-3/4" to 63"	27-3/8" x 60-1/4" x 82-1/4"	\$3,360.00
VHPS-2000-AA-A	Manual Hand Hydraulic	2,000 lbs.	1-3/8" to 63"	46" x 60-1/4" x 82-1/2"	\$3,825.00

Model VHPS-2000-FF



Shipping included!*



Model WVS-770-AA

Model WVS-770-FF

Manual Hand Winch Stackers

Manual Hand Winch Stackers feature a heavy duty mast and a unique winch design for easier and safer lifting. Lift and lower by hand winch and steel cable mechanism. 1" lift per handle revolution. Two rigid and two swivel wheels with brakes for easy maneuvering.

ITEM	DESCRIPTION	CAPACITY	SERVICE RANGE	OVERALL SIZE (WXLXH)	PRICE
VWS-770-FF-A	Manual Hand Hydraulic	770 lbs.	3-3/8" to 59"	24-1/2" x 46-5/8" x 78"	\$2,390.00
VWS-770-AA-A	Manual Hand Winch	770 lbs.	1-9/16" to 59"	42-1/8" x 46-5/8" x 78"	\$2,470.00

Shipping included!*

Combination Hand Pump and Electric Stacker

An economical alternative DC powered lift stacker. Ideal for maintenance and commercial applications. This unit can be used as a manual hand pump lift and electric powered lift. Ideal when power is not available. High quality hydraulic pump and DC lift system. Compact design and strong steel profile construction. An economical lift to handle tasks such as transporting dies, molds, and skids. Powered with two (2) 12V, 40Ah batteries. Integral battery charger, battery level gauge, and adjustable lowering speed. All models are easily maneuverable using the standard series pull handle. Individual forks are 6" wide.

ITEM	DESCRIPTION	CAPACITY	SERVICE RANGE	OVERALL SIZE (WXLXH)	PRICE
SE/HP-63-B	Combination Hand Pump and Electric Stacker	2,000 lbs.	3-3/8 - 63"	26-3/4" x 42"	\$6,080.00
SE/HP-98-B	Combination Hand Pump and Electric Stacker	2,000 lbs.	3-3/8 - 98"	26-3/4" x 42"	\$6,805.00
SE/HP-118-B	Combination Hand Pump and Electric Stacker	2,000 lbs.	3-3/8 - 118"	26-3/4" x 42"	\$7,290.00

Model SE/HP-63-B



Shipping included!*



Hand Pump L-220-HD & L-270-HD

DC Powered L-220-DC-HD & L-270-DC-HD

Tote Lifter

Designed to lift open bottom skids, boxes and baskets. Two operations available: hand pump and 12V DC power with rocker switch to raise or lower. Hand pump design features an ergonomic pump handle with two lifting speeds to accommodate for light or heavy loads. Side stabilizers provide balance to the unit when the load is lifted.

ITEM	DESCRIPTION	CAPACITY	SERVICE RANGE	FORK SIZE (WxL)	PRICE
L-220-HD-B	Hand Pump	3,000 lbs.	3-1/2" to 31-1/2"	20" x 43"	\$2,190.00
L-270-HD-B	Hand Pump	3,000 lbs.	3-1/2" to 31-1/2"	27" x 43"	\$2,205.00
L-220-DC-HD-B	12V DC Powered	3,000 lbs.	3-1/2" to 31-1/2"	20" x 45"	\$4,520.00
L-270-DC-HD-B	12V DC Powered	3,000 lbs.	3-1/2" to 31-1/2"	27" x 45"	\$4,645.00

* Shipping included to most major cities, surcharges may apply to Quebec & Atlantic Canada. Prices are subject to change without notice.



Mobile Safety Ladder Stands

- 42" high handrail
- 15" deep platform
- 1" x 16 ga. round tubing construction
- 6" x 2" polyolefin rear wheels
- 5" x 1 1/4" RSX rubber swivel casters
- Positive floor locking trip step mechanism
- 24" wide x 7 1/2" deep non-slip perforated step material
- 33" overall width
- 300 lb. capacity
- Painted blue enamel

Meets or exceeds CSA Safety Standards as per ANSI A14.7 and OSHA 1910.27

ITEM	STEPS	PLATFORM HEIGHT	STEP WIDTH	BASE SIZE	WEIGHT	SIZE	PRICE
1H-A*	1	9"	24"	26" x 19"	32 lbs.	26" x 20" 52"	\$240.00
2H-A*	2	18"	24"	26" x 24.5"	42 lbs.	26" x 20" 60"	\$280.00
3H-A*	3	27"	24"	26" x 29.5"	55 lbs.	26" x 23" 69"	\$330.00
4H-A	4	36"	24"	33" x 34.5"	87 lbs.	33" x 30" 78"	\$390.00
5H-A	5	45"	24"	33" x 40"	97 lbs.	33" x 44" 96"	\$440.00
6H-A	6	54"	24"	33" x 45.25"	111 lbs.	33" x 44" 108"	\$465.00
7H-A	7	63"	24"	33" x 50.5"	122 lbs.	33" x 51" 120"	\$650.00
8H-A	8	72"	28"	36" x 55.75"	142 lbs.	36" x 30" 126"	\$870.00
9H-A	9	81"	28"	36" x 61"	154 lbs.	36" x 30" 132"	\$905.00
10H-A	10	90"	28"	36" x 66.25"	166 lbs.	36" x 30" 144"	\$990.00
11H-A	11	99"	28"	36" x 71.5"	178 lbs.	36" x 30" 156"	\$1,090.00
12H-A	12	108"	28"	36" x 76.33"	190 lbs.	36" x 30" 168"	\$1,110.00
13H-A	13	117"	28"	36" x 82"	202 lbs.	36" x 30" 180"	\$1,215.00
14H-A	14	126"	28"	36" x 87.25"	214 lbs.	36" x 30" 186"	\$1,290.00
15H-A	15	135"	28"	36" x 92.5"	226 lbs.	36" x 30" 198"	\$1,345.00
16H-A	16	144"	28"	36" x 97.75"	238 lbs.	36" x 30" 204"	\$1,375.00

* Standard with 3" swivel spring loaded casters (others have positive floor locking trip step mechanism) Options: Front or side walk through | Extended platforms | Aluminum or Stainless Steel construction | Model higher than 16 steps available - call for details and pricing

Manual Brush Sweeper

Create a cleaner workplace without sacrificing productivity - this unit sweeps faster and better than four workers! This time saving push sweeper is great for commercial or industrial use. The Jan-II is made of heavy duty all-steel and the non-slip drive wheels offer positive traction while maintaining a quiet operation.



JAN-II-B **\$1,675⁰⁰** Shipping included!*

Multi-Surface Magnet



The Multi-Surface Magnet comes with 7" wheels and a removable handle for easy storage. Powerful magnets are enclosed in a heavy gauge aluminum shell. This magnet works well over concrete, grass, gravel, etc.

- 24" Multi-Surface Magnet
MSM24-A **\$500⁰⁰**
- 30" Multi-Surface Magnet
MSM30-A **\$520⁰⁰**
- 36" Multi-Surface Magnet
MSM36-A **\$570⁰⁰**
- 48" Multi-Surface Magnet
MSM48-A **\$640⁰⁰**

Shipping included!*

ValuSweep

- Broom height: 9"
- Bristle height: 8"
- Brush rows: 5
- Quick-Tite fork mount: Standard (5" width)
- Brush sections: replaceable polypropylene
- Broom mainframe: one-piece, solid aircraft aluminum extrusion
- Mounting hardware: high-quality powder-coated steel
- Optional accessories: magnetic bar, dust mop



48" ValuSweep
VSWP-48-A **\$1,310⁰⁰**

Replacement Brush 48"
VSWP-48-RB-A **\$440⁰⁰**

60" ValuSweep
VSWP-60-A **\$1,410⁰⁰**

Dust Mop Attachment 60"
VSWP-60-DM-A **\$345⁰⁰**

Replacement Brush 60"
VSWP-60-RB-A **\$545⁰⁰**

Shipping included!*



Versatile operation
Broom works in either push or pull mode.

Quick-Tite fork pockets
Simply attach to most forklifts.

Easy brush replacement
Features long lasting polypropylene fixed brush sections.

Optional dust mop
Ideal for sweeping fine material on polished floors.

Magnetic Sweeper

By applying pressure to any of the attachment toe plates, this unique design allows easy and safe debris removal. A simple and effective operation, debris is released from the hinged aluminum collector plate at your convenience!



36" AR Magnetic Sweeper
36ARFP-B **\$895⁰⁰**

48" AR Magnetic Sweeper
48ARFP-B **\$965⁰⁰**

60" AR Magnetic Sweeper
60ARFP-B **\$1,060⁰⁰**

72" AR Magnetic Sweeper
72ARFP-B **\$1,180⁰⁰**

Shipping included!*

* Shipping included to most major cities, surcharges may apply to Quebec & Atlantic Canada. Prices are subject to change without notice.

For updated pricing or to place your order online visit: www.liftow.com

MATERIAL HANDLING

Handy-Mag Trio

Make your warehouse operate as efficiently as possible with the Handy-Mag Trio Set. These products are always available when you need them, where you need them with their powerful 100 lbs test magnet. The Handy-Mag products can be mounted on the forklift, pallet truck, work stations, warehouse racking, or anywhere that is metal.

Trio includes:

- Handy-Mag Tape Gun
- Handy-Mag Clipboard
- Handy-Mag Utility Box



MAGTRIO-E..... **\$60⁰⁰**

Handy-Mag Tape Gun

This high quality tape gun with 100 lbs test magnet makes packaging and shipping a breeze. Use the magnet to place your tape gun on any metal surface for easy access and convenience.

- Measures 9½" x 6" x 2¾" at 2 lbs
- For use with 2" tape rolls (not included)
- Equipped with blade cover flap to prevent injury
- (1) 100 lbs test strength magnet
- Ergonomic rubber hand grip
- Metal frame



Comfort Grip Rubber Handle

100 lb. Magnet

MAGGUN-E **\$24⁹⁵**

Buy 5 or more units **\$20⁰⁰/ea**

Handy-Mag Clipboard

This durable aluminum clipboard with 100 lbs test magnet allows you to carry important paperwork such as packing slips, invoices, work orders, inventory lists or checklists anywhere. Paperwork will never be lost or misplaced. Use the magnet to place your clipboard on any metal surface for easy access and convenience.

- Measures 9" x 12½" at 1 lb
- For use with 8½" x 11" sheets of paper
- Equipped with spring loaded clip
- (1) 100 lbs test strength magnet
- Flexible and durable aluminum construction



100 lb. Magnet keeps the clipboard in place



MAGBOARD-E **\$24⁹⁵**

Buy 5 or more units **\$20⁰⁰/ea**

Handy-Mag Utility Box

Use this multi-purpose utility box to carry pens, box cutters, markers, scissors, tools and more. The Handy-Mag Utility Box can also be used as a drink holder on a forklift or on any powered industrial truck. The box can hold and fit a bottle of water, canned drink or coffee cup securely. Includes (1) 100 lbs test magnet that can attach to the bottom or side of the box (Optional second magnet available). Use the magnet to place your utility box on any metal surface for easy access and convenience.

- Measures 4" x 3½" x 5¼"H at 2 lbs
- Holds various sizes of tools and drinks
- (1) 100 lbs test strength magnets
- Durable nylon construction



100 lb. magnet on the side or the bottom



MAGBOX-E **\$24⁹⁵**

Buy 5 or more units **\$20⁰⁰/ea**

Extra Magnets **MAGNET-C... \$8⁵⁰**

INDEX

A

ABC's of Fall Protection DVD.....	29
Accu-Height.....	46
Accu-Tilt.....	46
AICHI.....	22
All-Krete.....	57
All Terrain Pallet Truck.....	71
Anti-Blind Spot Dome Mirror.....	45
Anti-Vibration Seat Cushion.....	59
Arrow Blue Light.....	42
Atrium Forklift Enclosure.....	49
Attachments.....	61–64

B

Back Rests.....	59
Back Safety 101.....	30
Batt 1000.....	35
Batteries, Forklift.....	20
Battery Acid Spill Kit.....	33
Battery Cable Connectors.....	35
Battery Cable Magnet.....	35
Battery Cable Tower.....	35
Battery Care Box.....	34
Battery Handling PPE Kit.....	34
Battery Lifting Beam.....	35
Battery Roller Service Stands.....	36
Battery Safety.....	31–36
Battery Transfer Cart.....	36
Battery Watering Cart.....	32
Battery Watering Gun.....	31
Battery Watering System.....	31
Big Blue Light.....	42
Bio Med Wash.....	33
Booms, Forklift.....	64
Brass Coupler.....	37
Brite-Lite LED Headlight.....	41

C

Cap-Off Battery Cap Removal Tool.....	34
Carbon Monoxide Detector.....	37
Carpet Poles/Rug Rams.....	63
Cascade™.....	19
Chameleon LED Dock Light.....	70
Checklist Caddy.....	43
ClearCap™.....	49
Code-Red Forklift Detection System.....	51
Column Protectors.....	54
Corner Protectors.....	54

D

Danger Zone Pedestrian Safety DVD Kit.....	29
Dissipater.....	31
Dock Accessories/Equipment.....	67–70
Dock Boards.....	68
Drum Carrier.....	65
Drum Grippers.....	66
Drum Handlers.....	65

Drum Lifter/Wrench.....	65
Drum Positioner.....	66

E

ECO Blue Light.....	42
ECO LED Forklift Headlight.....	41
Electronic Code Switch.....	58
Ergo Back-up Handle.....	45
Ergonomics.....	59
EZ-Fit Harness and Landyards.....	39

F

Facility Protection.....	54–58
Fall Protection.....	39
Fork Cushions.....	54
Fork Extensions.....	62
Fork-Kushions.....	56
Fork Mounted Trash Can Dumper.....	61
Forkshield Overhead Guard Rain Shields.....	49
Fork Truck Snow Plow.....	61

G

Gravity Feed Eye Wash.....	33
----------------------------	----

H

Handy-Mag Clipboard.....	74
Handy-Mag Tape Gun.....	74
Handy-Mag Utility Box.....	74
Heat Shrink PVC Battery Cable Protector.....	32
Hoisting Hooks.....	61
Hydrosep.....	33

L

Laser-Guide Fork Guidance System.....	47
Leak Detection Compound.....	37
LED Lights.....	41–42
Lift-Rite Pallet Truck.....	71
Lift Truck Log.....	43
Lock-Out Box.....	48
Lockout/Tagout DVD.....	30
Lock-Out Tags.....	48
LOOK-OUT™ Collision System.....	51
Low Propane Fuel Gauge.....	38
Low Propane Fuel Indicator Kit.....	38
LP Cylinder Loader.....	38
LPG Safety Grip.....	37

M

Magnetic Stability Training Model.....	29
Magnetic Sweeper.....	73
Manual Brush Sweeper.....	73

Mega Mirror.....	45
Mirrors.....	45
More High Impact Forklift Safety DVD.....	29
Multi-Surface Magnet.....	73

N

Non-Skid Floor Coating.....	57
-----------------------------	----

O

Overhead Door Track Protector.....	54
------------------------------------	----

P

Pallet Dawg Carriage Bumper.....	55
Pallet Dumper/Retainer.....	61
Pallet Pullers.....	68
Pallet Truck with Scale.....	40
Parts.....	14
Portable Floor Scale.....	40
Portable Loading Platform.....	61
Portable Safety Zone Barrier System.....	56
Programmed Maintenance.....	15
Propane Cylinder Caddies.....	38
Propane Cylinder Exchange DVD.....	30
Propane Cylinder Gloves.....	37
Propane Cylinder Storage Cabinets.....	38
Propane PPE Kit.....	37
Propane Safety.....	37–38

Q

QuickMount Safety Barricade.....	58
----------------------------------	----

R

Rack Armor.....	58
Red-Zone LED Warning Light.....	41
Rentals.....	13
Retracto-Glove.....	37
Rough Terrain Training DVD.....	30

S

Safe-Belt.....	60
Safe-Bump Forklift Bumpers.....	55
SAFE-Lift Counterbalance DVD.....	27
SAFE-Lift Narrow Aisle DVD.....	27
SAFE-Lift Pallet Truck DVD.....	27
SAFE-LITE.....	42
Safe-Speed.....	53
Safe-Tilt.....	46
Safety Accessories.....	43–50
Safety Ladder Stands.....	73
Safety Signs.....	50
Safety Stickers.....	50

Safe-View Wireless Camera.....	53
Safe-Weigh Hydraulic Scale.....	40
SB Connector Lockbox.....	48
Scale Model Lift Trucks.....	29
Scales.....	40
Seat Belts.....	60
Seats.....	59
Self-Dumping Hoppers.....	63
Service.....	15
Side-View Mirror.....	45
SideWinder Pallet Truck.....	71
SkidSteer DVD Training.....	30
Speed Saver.....	58
Structural Rack Guards.....	54
Support Materials.....	27

T

The Backbone™.....	50
Toyota.....	3–6
Toyota Commercial Finance.....	18
Toyota T-Matics.....	9
Traffic Vest.....	55
Trailer Stabilizing Jacks.....	68
Training Videos/DVDS.....	27–30

U

Ultimate Training Package.....	28
Used Forklifts.....	12

V

ValuSweep.....	73
Versa Handler DVD.....	30

W

Wall Mounted Charger Brackets.....	36
Warehouse.....	17
Warehouse Mirrors.....	57
What's Wrong With This? DVD.....	29
Wheel Chocks.....	69
WHMIS 2015.....	28
Wire Lift Truck.....	29
Work Platform.....	63

Y

YellowBowl™ Shower/Eye Wash.....	33
----------------------------------	----



Stay connected! Follow @liftow

