

Elements

by TCP

LED Wall Pack

Product Specifications



TCP's non-cutoff LED Wall Pack combines the look of a traditional wall pack with the benefits of LED. An efficient alternative to HID, these wall packs deliver bright, uniform light while providing energy savings. A long 50,000 hour rated life significantly decreases maintenance labor and material costs over the life of the fixture.

The robust die-cast aluminum housing incorporates an impact-resistant polycarbonate lens. An integrated photocell is optional for dusk-to-dawn control. An integrated microwave motion sensor is optional for increased power savings. The wall pack mounts directly to a standard junction box for easy retrofit of traditional fixtures.

Reasons to choose the LED Wall Pack from TCP

- Energy efficient – Uses less energy than traditional fixtures, resulting in instant energy savings
- Long 50,000 hour rated life minimizes replacements and reduces overall labor costs throughout the life of the fixture
- UL approved for wet locations
- Durable die-cast aluminum housing with impact-resistant polycarbonate lens protects the LED in harsh environments

Ideal Applications

- Site Lighting
- Security Lighting
- Entrances
- Perimeters



Applications

This product family can be effectively used in outdoor wall mount locations in commercial, industrial, retail and institutional exterior lighting (i.e., parking lot, cargo door, high wall, area, security, etc).

Construction

- Die-cast aluminum housing
- Impact-resistant polycarbonate lens
- Durable dark bronze powdercoat
- Same footprint as existing HID wall packs
- Operating Temperature: -20°C to 40°C

Electrical

- cULus wet location rated
- Easy-to-access wiring compartment
- System rated for long 50,000 hour life
- Efficiently delivers up to 105 LPW
- Optional Photocell (PC)
- Optional Microwave Motion Sensor (MS)

Optics

- Prismatic polycarbonate lens
- Delivers bright, white light and excellent uniformity

Item Number	
Notes	Type



Listings

UL and cUL listed
RoHS Compliant
DLC v5.0 Standard

Warranty

Five year limited warranty against defects in manufacturing.

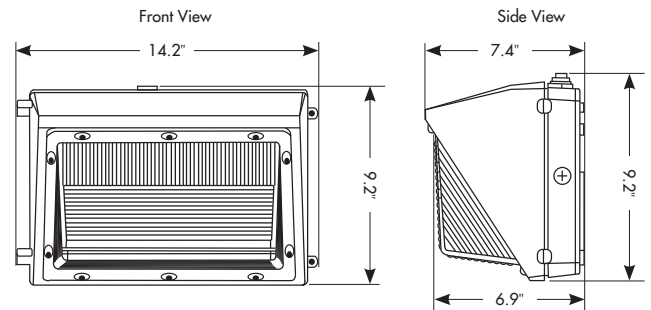

Catalog Ordering Matrix

Example: WP5500140K

HFP	4	U	COLOR TEMPERATURE	FACTORY INSTALLED OPTIONS:
FAMILY	LUMEN PACKAGE	VOLTAGE		
WP - Wall Pack	55 - 5800L (55W) 120 - 12600L (120W)	001 - 120-277V	40K - 4000K 50K - 5000K	Blank - No Add-on PC - Button Photocell MS - Microwave Bilevel dimming sensor

Field Installed Accessories:

Item Number	Description
CPEBATTERY	8W 90 min. waterproof emergency battery backup

INDICATES BREX EXPRESS



For the most up-to-date specs and warranty information, please visit www.tcp.com

TCP®

325 Campus Dr. | Aurora, Ohio 44202 | P: 800-324-1496 | tcp.com

©TCP APR 2022/WF169700



5 YEAR WARRANTY

Not all versions of this product are qualified on the DLC QPL. To view our DLC qualified products, please consult the DLC Qualified Products List at www.designlights.org/qpl.