



401 South Grand Ave., Santa Ana, CA 92705
Tel: 714.550.6070 Fax: 714.550.9661 www.twobros.com

Kawasaki ZRX1100 Flange-On Exhaust System



Parts List

QTY.	DESCRIPTION	PART NUMBER
1	MUFFLER CANISTER (17.5", RIGHT SIDE)	VARIES*
1	MUFFLER CLAMP	VARIES
4	8MM X 20MM FLANGE BOLTS	005-SH820
2	8MM WASHERS	005-WF8
1	8MM NYLOCK NUT	005-NN8
1	MUFFLER HANGER BRACKET	005-71B
2	TWO BROTHERS RACING STICKERS	015-10207



IMPORTANT - PLEASE READ CAREFULLY

We recommend that this performance exhaust system be installed by a qualified motorcycle technician. If you have any doubts as to your ability to install this exhaust system, please consult with your local motorcycle dealer. Read all instructions first before starting installation. Make sure the motorcycle and exhaust system are completely cool before starting the installation. Also, make sure the bike is secure on the sidestand or ideally a rear service stand during installation. Be sure to save all stock exhaust components for possible use later.

Installation Instructions

1. Make sure the bike is completely cool before starting the installation. Make sure the bike is secure on the sidestand or ideally a rear service stand.
2. Remove the nuts holding the stock canister onto the flange. Loosen the hardware that holds the canister to the passenger footpeg and remove the canister from the bike.
3. If your bike has the pipe extending past the flange you will need to trim it. This will not affect refitting the stock canister if you ever need to. **Be sure to measure twice and cut once!** Typically you can leave 1/2" of pipe extending past the flange face.
4. Install the canister onto the end of the stock exhaust flange (the TBR badge faces to the outside). You'll have to hold it in place while you start the 8mm x 20mm bolts through the flange holes and into the inlet. Go ahead and tighten evenly and fully.
5. Install the hanger bracket to the passenger footpeg bracket using the stock hardware. The bracket should point backward and down toward the canister. **Leave loose for now.**
6. Carefully slide the canister clamp over the canister. (**Note:** The stainless steel canister clamp and the name badge on the canister come from the factory with a clear plastic protective film. Please remove this film before operation.) Locate both tabs of the canister clamp on the outside of the hanger bracket. Use the 8mm x 20mm bolt, washers and nut to secure it. **Leave loose for now.**
7. Make sure everything is aligned and tighten all hardware.
8. Before you run the bike, clean off all fingerprints and dirt, as any oily residue will etch the metal and become somewhat permanent when the system gets hot. Run the bike and enjoy. It is normal for some white smoke to appear the first time you start the bike. This is packing/manufacturing oil from inside the pipe burning off. Check for gaps or leaks. If you find a leak, a little high temperature silicon sealant should fix it. After 50 to 100 miles, recheck all fasteners for tightness.

Canister Clamp Detail

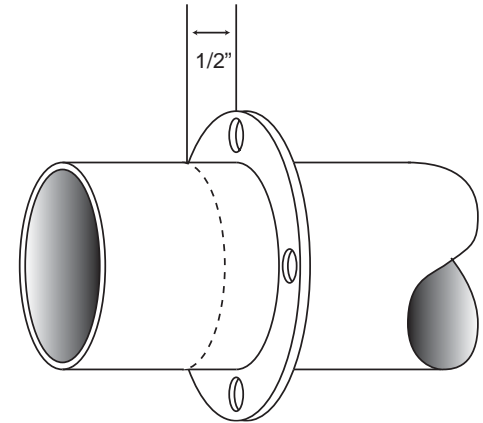

Canister Clamp Detail

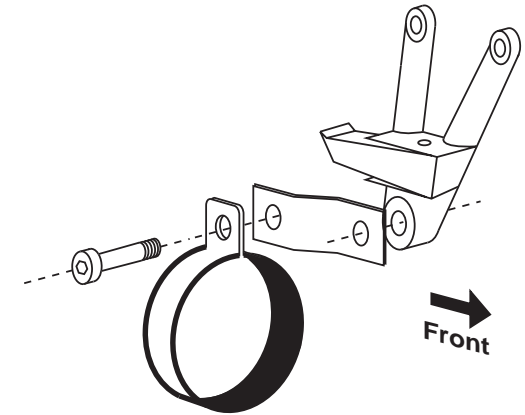

Care & Cleaning / Warranty

Care & Cleaning

Keep system free of dirt and moisture. Store in a cool, dry place. For cleaning use a mild spray cleaner. Always apply cleaner or polish with a soft, clean cloth.

Stainless Header System: Polished stainless steel pipes will turn a light golden hue after a few heat cycles, this is a normal characteristic of high quality stainless steel.

Carbon Fiber & X-Metal Mufflers: X-Metal CF canisters will shift color from their original silver color to an amber color after a few heat cycles, similar to the way our stainless steel headers shift color. Always make sure the fiberglass packing inside is in good condition and not burned out, as exhaust heat inside an empty canister will deteriorate the Carbon Fiber / X-Metal CF sleeve. TBR sells repack kits (TBR part # 005-1003B) that include new rivets and repack material as well as a drill bit (#30), making it easy to do yourself. Also, NEVER dyno test your bike with carbon fiber mufflers installed - the intense heat and lack of cooling air can quickly cause the CF material to burn. Two Brothers Racing does not provide a warranty for burned carbon fiber.

Aluminum Mufflers: Use an aluminum or mag wheel polish such as Mother's to restore the bright finish to factory spec.

Warranty

Two Brothers Racing products are intended for closed course competition purposes only, and therefore are sold "as is" without warranty. Two Brothers Racing specifically disclaims any warranties of merchantability or fitness for a particular purpose and disclaims all responsibility for consequential and incidental damages or any other losses arising from the use of these products or parts.