



401 South Grand Ave., Santa Ana, CA 92705 USA  
Tel: 714-550-6070 Fax: 714-550-9661 www.twobros.com

### Kawasaki KLX110 / Suzuki DR-Z110 Tapered Steering Head Bearing Kit



Part # 022-6-24

#### IMPORTANT - PLEASE READ CAREFULLY

*We recommend that this performance part be installed by a qualified motorcycle technician. If you have any doubts as to your ability to install this performance part, please consult with your local motorcycle dealer. Read all instructions first before starting installation. Make sure the motorcycle and exhaust system are completely cool before starting the installation. Also, make sure the bike is secure on the sidestand or ideally a rear service stand during installation. Be sure to save all stock components for possible use later.*

#### Warranty

Two Brothers Racing products are intended for closed course competition purposes only, and therefore are sold "as is" without warranty. Two Brothers Racing specifically disclaims any warranties of merchantability or fitness for a particular purpose and disclaims all responsibility for consequential and incidental damages or any other losses arising from the use of these products or parts.

#### Installation Instructions

1. Make sure the bike is completely cool before starting the installation. Make sure the bike is secure on the sidestand or ideally a rear service stand.
2. Remove front wheel and front number plate.
3. Remove handlebar clamps (#1) then handlebars (#2).
4. Remove steering stem head nut (#3) and washer.
5. Loosen pinch bolts on upper (#4) triple clamp and remove.
6. While holding the lower triple clamp, remove stem locknut (#5). Carefully lower and remove the steering stem.
7. Remove bearings from upper (#6) and lower outer (#8) races.
8. Remove the upper (#12) and lower (#11) races by using a punch to evenly tap around the circumference of the races.
9. With a drift remove the lower inner race (#10) from the steering stem.
10. Install **new** lower dust shield and inner race onto steering stem by evenly tapping around the circumference of the race. Lower inner race has an I.D. of 27.8mm. The dust shield is installed under the lower inner race. **Be sure race and lower dust shield is fully seated.**
11. Install **new** lower and upper outer races by using a punch to evenly tap around the circumference of the races. Using the old outer races as a tapping block will help to fully install new outer races into frame.
12. Pack bearing with high quality water proof grease.
13. Insert steering stem assembly into frame.
14. Install the stem locknut (#5) onto steering stem and tighten until no rattle or play is present. **Do not overtighten!**
15. Loosely install upper triple clamp onto steering stem.
16. Install fork legs into triple clamps aligning the top end of the inner tube with the upper surface of the upper triple clamp. Install steering stem head nut and washer and torque to spec. Torque pinch bolts to spec.
17. Reinstall handlebars, torque handlebar clamp bolts to 18 ft-lb.
18. Reinstall front wheel and reconnect front brake cable. Torque front axle nut to 36 ft-lb.

19. Double check throttle and brake cable routing. Double check all fasteners!
20. Ride bike for 30 minutes, then check bearing adjustment for any loosening. Your pre-race prep should always include a steering bearing check whether you use this new lower triple or the stock Kawasaki triple clamp.

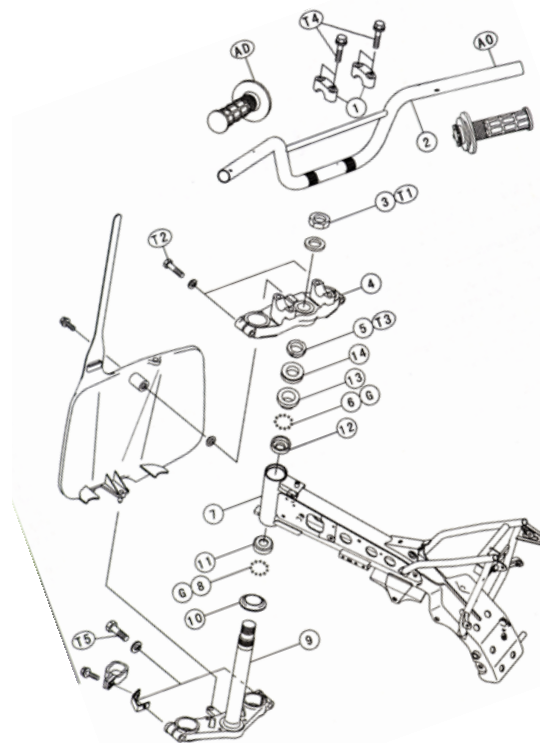

Torque Specs	
Steering Stem Head Nut	32 ft-lb
Upper Triple Clamp Pinch Bolts	15 ft-lb
Lower Triple Clamp Pinch Bolts	22 ft-lb