



401 South Grand Ave., Santa Ana, CA 92705  
Tel: 714.550.6070 Fax: 714.550.9661 www.twobros.com



## Hyosung GT650R/S

Flange-on Exhaust System with M-2 Canister  
Part # 005-2150406M



### Parts List

Qty.	Description	Part Number
1	M-2 Muffler Canister	Varies
1	Muffler Clamp	005-2C
1	HARDWARE KIT	005-215-3
1	Permatex Ultra Black Gasket Maker	031-P22072

### IMPORTANT - PLEASE READ CAREFULLY

**We recommend that this performance part be installed by a qualified motorcycle technician. If you have any doubts as to your ability to install this performance part, please consult with your local motorcycle dealer. Read all instructions first before starting installation. Make sure the motorcycle and exhaust system are completely cool before starting the installation. Also, make sure the bike is secure on a centerstand or ideally a service lift during installation. Be sure to save all stock components for possible use later.**

### Warranty

Two Brothers Racing products are intended for closed course competition purposes only, and therefore are sold "as is" without warranty. Two Brothers Racing specifically disclaims any warranties of merchantability or fitness for a particular purpose and disclaims all responsibility for consequential and incidental damages or any other losses arising from the use of these products or parts.

### Installation Instructions

1. Make sure the bike is completely cool before starting the installation. Make sure the bike is secure on center stand or ideally a service lift.
2. Remove the nuts holding the stock canister onto the flange. Loosen the hardware that holds the canister to the passenger footpeg and remove the canister from the bike.
3. Your bike has the pipe extending past the flange you will need to trim it. This will not affect refitting the stock canister if you ever need to. Be sure to measure twice and cut once! Typically you can leave 1/2" of pipe extending past the flange face (use a hacksaw).
4. Install the canister onto the end of the stock exhaust flange (the TBR badge faces to the outside). You'll have to hold it in place while you start the OEM bolts through the flange holes and into the inlet. Go ahead and tighten evenly and fully. (Use Hi-temp silicone on gasket.)
5. Carefully slide the canister clamp over the canister. (Note: The stainless steel canister clamp and the name badge on the canister come from the factory with a clear plastic protective film. Please remove this film before operation.) Locate both tabs of the canister clamp on the outside of the hanger bracket. Use the OEM bolt, washers and nut to secure it. Leave loose for now.
6. Make sure everything is aligned and tighten all hardware.
7. Before you run the bike, clean off all fingerprints and dirt, as any oily residue will etch the metal and become somewhat permanent when the system gets hot. Run the bike and enjoy. It is normal for some white smoke to appear the first time you start the bike. This is packing/manufacturing oil from inside the pipe burning off. Check for gaps or leaks. If you find a leak, a little high temperature silicon sealant should fix it. After 50 to 100 miles, recheck all fasteners for tightness.

### Flange cut detail

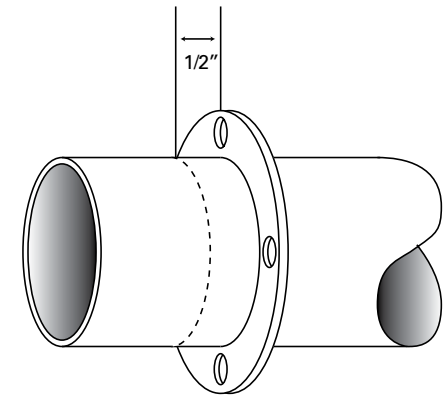

### Care & Cleaning

#### Care & Cleaning

Keep system free of dirt and moisture. Store in a cool, dry place. Make sure vehicle is completely cool before maintenance.

**Stainless Header System:** Polished stainless steel pipes will turn a light golden hue after a few heat cycles, this is a normal characteristic of high quality stainless steel. Clean using a mild water based spray cleaner. Always apply cleaner or polish with a soft, clean cloth.

**Titanium Header System:** Polished titanium pipes will experience color shift ranging from deep blue/purple through amber after a few heat cycles. This is a normal characteristic of high quality titanium. Clean using a mild water based spray cleaner. Always apply cleaner or polish with a soft, clean cloth.

**Polished Aluminum Canisters:** Use an aluminum or mag wheel polish to restore the bright finish to factory spec.

**Brushed Aluminum Canisters:** Clean using a mild water based spray cleaner. Always apply cleaner or polish with a soft, clean cloth.

**Carbon Fiber Canisters:** Clean using a mild water based spray cleaner. Always apply cleaner or polish with a soft, clean cloth. Always make sure the fiberglass packing inside is in good condition and not burned out, as exhaust heat inside an empty canister will deteriorate the carbon fiber sleeve. TBR sells repack kits (Road - #005-10038, Offroad - #005-10038MX) that include everything you need to easily do it yourself.

**Titanium Mufflers:** For cleaning use a mild water based spray cleaner. Always apply cleaner or polish with a soft, clean cloth. Always make sure the fiberglass packing inside is in good condition and not burned out, as exhaust heat inside an empty canister will deteriorate the carbon fiber sleeve. TBR sells repack kits (Road - #005-10038, Offroad - #005-10038MX) that include everything you need to easily do it yourself.

Repack all road canisters at the first signs of packing material deterioration. Part #005-10038 Repack all offroad canisters after every 10 hours of use. Part #005-10038MX

**NEVER** dyno test your bike with carbon fiber or titanium canisters installed - the intense heat and lack of cooling air can quickly burn through the canister material. Two Brothers Racing does not provide a warranty for burned canisters.



401 South Grand Ave., Santa Ana, CA 92705  
Tel: 714.550.6070 Fax: 714.550.9661 www.twobros.com



**Hyosung  
GT650R/S**

Flange-on Exhaust System with M-2 Canister  
Part # 005-2150406M



005-2150406M

005-2150407M

005-2150408M



Qty.	Description	Part Number
1	M-2 Muffler Canister	Varies
1	Muffler Clamp	005-2C
1	HARDWARE KIT	005-215-3
1	Permatex Ultra Black Gasket Maker	031-P22072



Qty.	Description	Part Number
1	M-2 Muffler Canister	Varies
1	Muffler Clamp	005-2C
1	HARDWARE KIT	005-215-3
1	Permatex Ultra Black Gasket Maker	031-P22072



Qty.	Description	Part Number
1	M-2 Muffler Canister	Varies
1	Muffler Clamp	005-2C
1	HARDWARE KIT	005-215-3
1	Permatex Ultra Black Gasket Maker	031-P22072