



401 South Grand Ave., Santa Ana, CA 92705 USA
Tel: 714-550-6070 Fax: 714-550-9661 www.twobros.com

Aprilia Falco Dual Slip-On Exhaust System



Parts List

QTY.	DESCRIPTION	PART NUMBER
1	MUFFLER (17.5", RIGHT SIDE)	VARIES
1	MUFFLER (17.5", LEFT SIDE)	VARIES
2	MUFFLER CLAMP	VARIES
1	S-BEND TUBE	-
	LEFT SIDE	005-1804NL
	RIGHT SIDE	005-1804NR
4	80MM SPRINGS	005-S80
2	18MM SPACER	005-S-18
2	8MM X 60MM SOCKET HEAD CAP SCREW	N/A
2	8MM WASHERS	N/A
1	HI-TEMP SEALANT	031-P22072
2	TWO BROTHERS RACING STICKERS	015-10197



005-1804

IMPORTANT - PLEASE READ CAREFULLY

We recommend that this performance exhaust system be installed by a qualified motorcycle technician. If you have any doubts as to your ability to install this exhaust system, please consult with your local motorcycle dealer. Read all instructions first before starting installation. Make sure the motorcycle and exhaust system are completely cool before starting the installation. Also, make sure the bike is secure on the sidestand or ideally a rear service stand during installation. Be sure to save all stock exhaust components for possible use later.

Installation Instructions

1. Make sure the bike is completely cool before starting the installation. Make sure the bike is secure on the sidestand or ideally a rear service stand.
2. Unhook the springs that hold the stock canisters to the headers.
3. Remove the bolts that attach the stock canisters to the footpegs.
4. Take off the stock canisters.
5. Place a bead of hi-temp sealant on the outside edge of the headers that goes into the TBR s-bends. Slide the S-bends onto the end of the headers. **Leave loose for now.**
6. Place a bead of the hi-temp sealant on the outside edge of the s-bend that goes into the canisters. Slide the TBR canisters onto the end of the S-bend pipes. Wipe off the excess sealant that will squeeze out.
7. Carefully slide the canister clamps over the canisters. (Note: The stainless steel canister clamp and the name badge on the canister come from the factory with a clear plastic protective film. Please remove this film before operation.) You may need to twist and turn the S-bends a little to get it in the right place. Using the aluminum spacer, place it between the clamp and the footpeg bracket, place it between the clamp and the footpeg bracket. Attach it to the footpeg bracket using the longer bolt provided and stock nut. **Leave loose for now.**
8. Make sure everything is aligned and tighten all hardware. Affix the connector springs to the muffler.
9. Before you run the bike, clean off all fingerprints and dirt, as any oily residue will etch the metal and become somewhat permanent when the system gets hot. Run the bike and enjoy. It is normal for some white smoke to appear the first time you start the bike. This is packing/manufac-

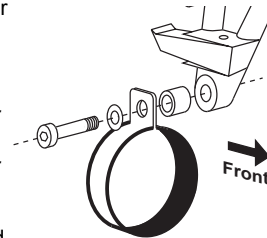

turing oil from inside the pipe burning off. Check for gaps or leaks. If you find a leak, a little high temperature silicon sealant should fix it. After 50 to 100 miles, recheck all fasteners for tightness.

OE Exhaust System

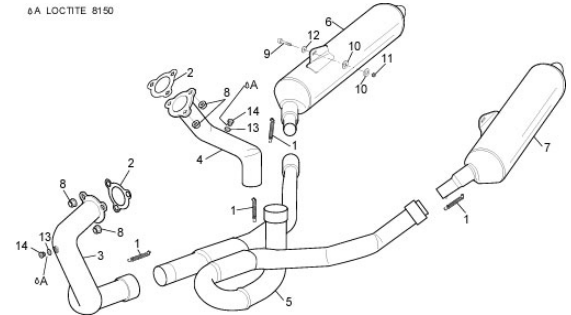

Care & Cleaning / Warranty

Care & Cleaning

Keep system free of dirt and moisture. Store in a cool, dry place. For cleaning use a mild spray cleaner. Always apply cleaner or polish with a soft, clean cloth.

Stainless Header System: Polished stainless steel pipes will turn a light golden hue after a few heat cycles, this is a normal characteristic of high quality stainless steel.

Chrome Header System: Chromed header tubing will turn blue close to the exhaust ports, this is normal. To prevent corrosion you must keep the header pipes clean.

Carbon Fiber & X-Metal Mufflers: X-Metal CF canisters will shift color from their original silver color to an amber color after a few heat cycles, similar to the way our stainless steel headers shift color. Always make sure the fiberglass packing inside is in good condition and not burned out, as exhaust heat inside an empty canister will deteriorate the Carbon Fiber / X-Metal CF sleeve. TBR sells repack kits (TBR part # 005-10038) that include new rivets and repack material as well as a drill bit (#30), making it easy to do yourself. Also, NEVER dyno test your bike with carbon fiber mufflers installed - the intense heat and lack of cooling air can quickly cause the CF material to burn. Two Brothers Racing does not provide a warranty for burned carbon fiber.

Aluminum Mufflers: Use an aluminum or mag wheel polish such as Mother's to restore the bright finish to factory spec.

Warranty
Two Brothers Racing products are intended for closed course competition purposes only, and therefore are sold "as is" without warranty. Two Brothers Racing specifically disclaims all warranties of merchantability or fitness for a particular purpose and disclaims all responsibility for consequential and incidental damages or any other losses arising from the use of these products or parts.