



RETENTION CABLE
Installation Instructions Van:
VNNS11NSNV55

NISSAN NV
146" WHEELBASE
2011-CURRENT

Watch short installation videos at www.decked.com/video | Register your system at www.decked.com/warranty

FOLLOW US:      @DECKEDUSA | #DECKEDUSA

VERSION 5

DECKED.COM | 208.806.0251

RETENTION CABLE INSTALLATION

This view is to orient yourself to the vehicle, the DECKED System installed using the installation procedures that came with your system, and how the van cables should appear when the cable installation process is complete.

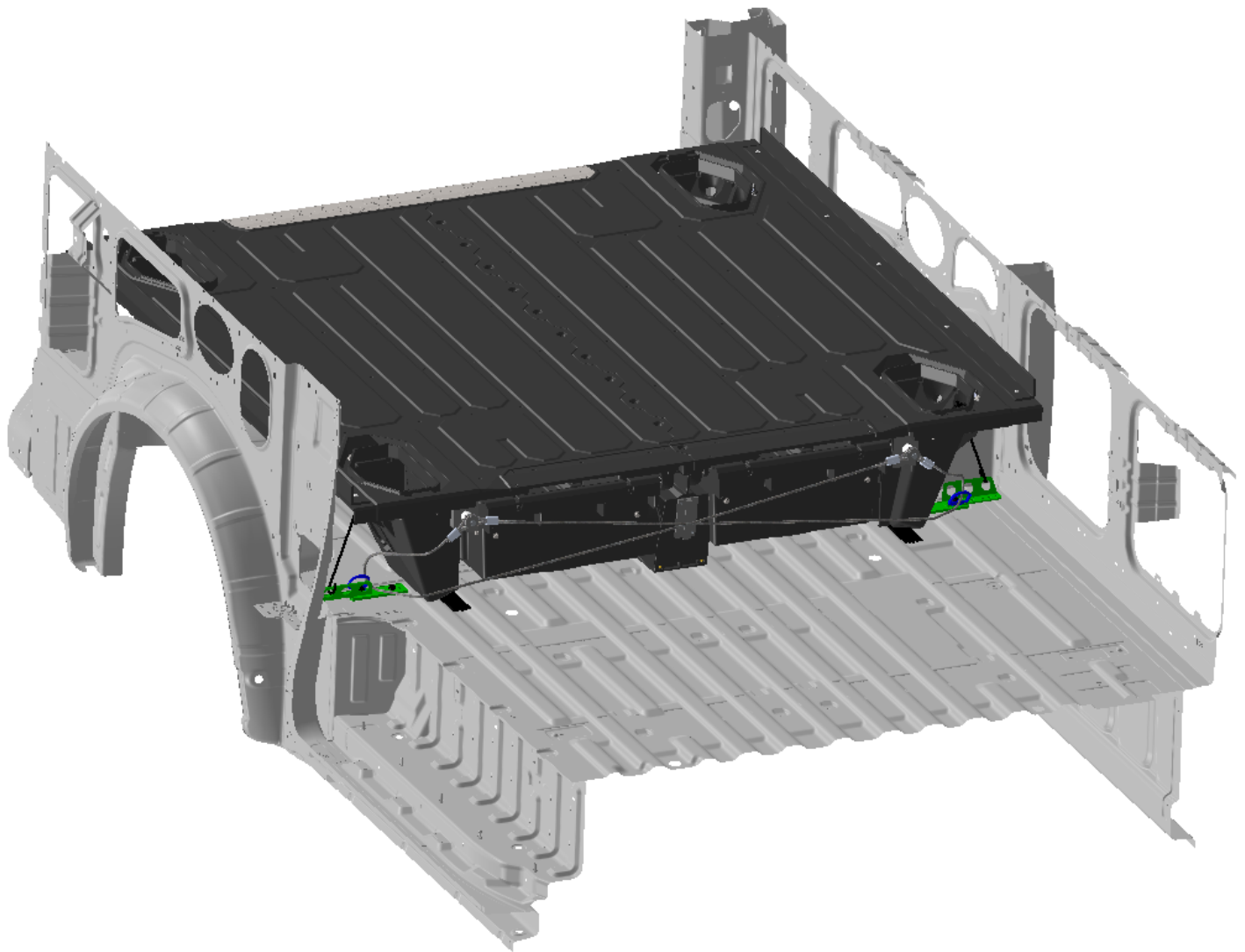

RETENTION CABLE INSTALLATION

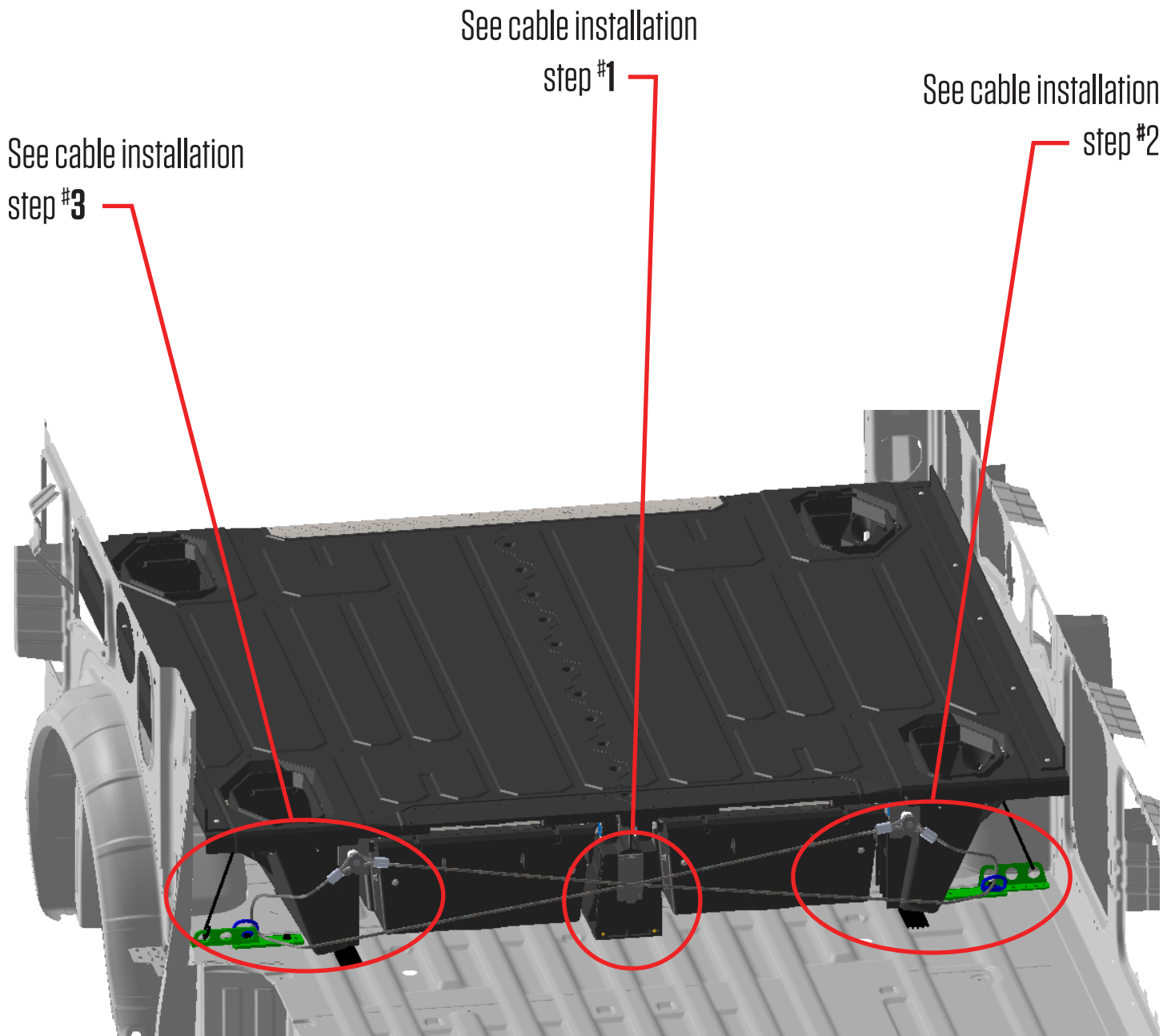

RETENTION CABLE INSTALLATION

Cable Installation – Step #1 –

- Center cable standoff to center vert and align top edge of standoff to bottom of drawer wheel channel.
- Run two #8 self-tapping screws, diagonally oriented as shown in image below, thru cable standoff and into center vert; **BAG VAN CABLE KIT**.

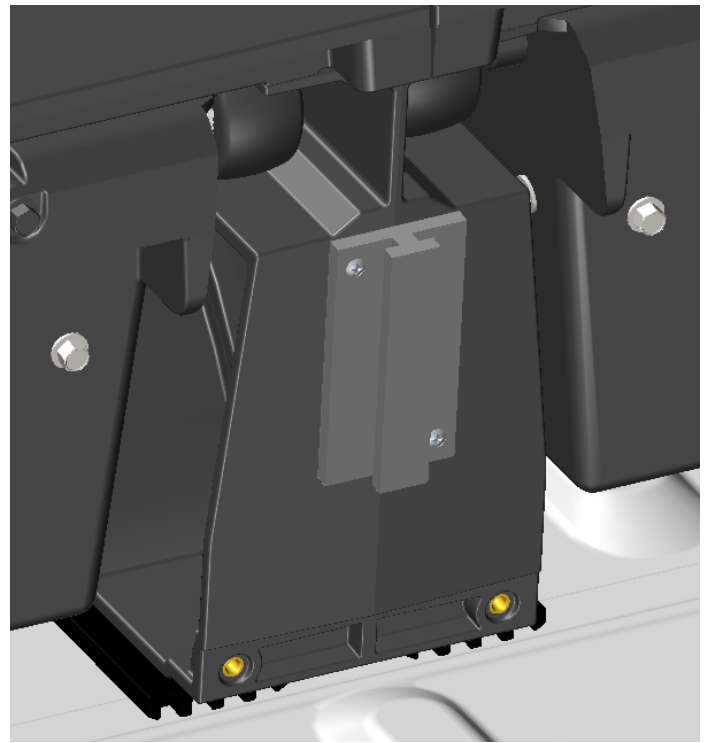
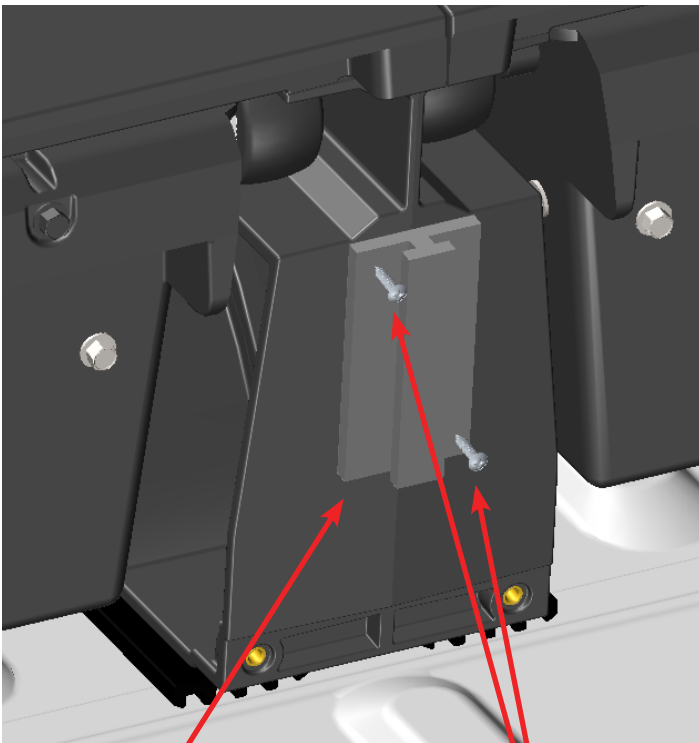

cable standoff

#8 self tapping screws

RETENTION CABLE INSTALLATION

Cable Installation – Step #2 –

Please note: the cables are of different lengths and marked LH & RH. The RH cable is longer.

- Starting on the driver side of the vehicle, loop LH cable eye thru cargo tie down ring (shown in blue in assembled view) on the cabside of the J-hook; **BAG VAN CABLE KIT**. Do not loop through mounting bracket (shown in green).
- Assemble LH and RH cable ends in the order depicted in the exploded view image, i.e. bolt thru washer, then thru RH cable eye and then LH cable eye, then thru 1 1/2" steel spacer and the thru 3/4" nylon spacer, thru hole in C-channel end plate and into nut; **BAG VAN CABLE KIT**.

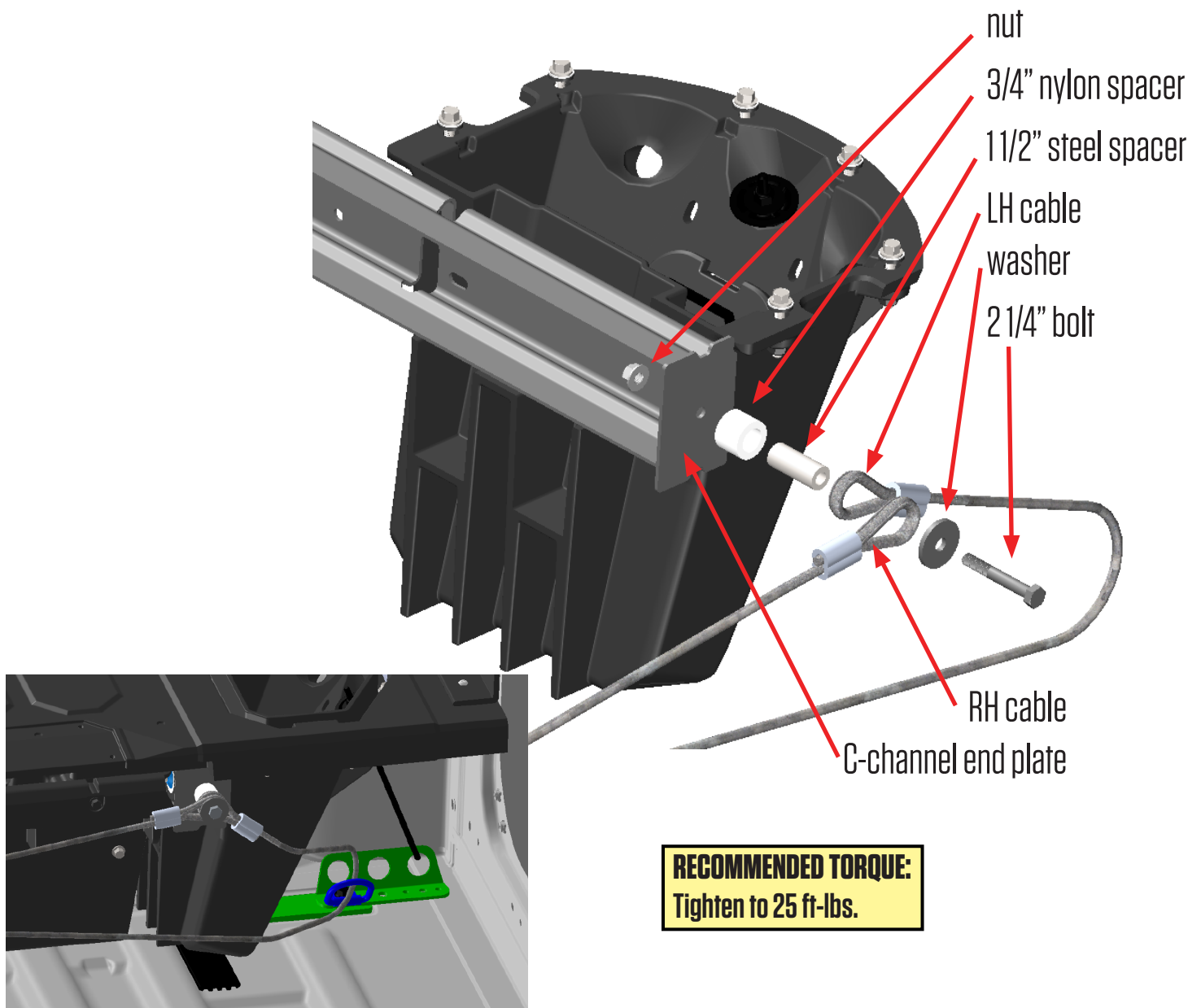

RECOMMENDED TORQUE:
Tighten to 25 ft-lbs.

RETENTION CABLE INSTALLATION

Enlargement of LH cable assembly attachment to cargo tie down loop (shown in blue).
Do not loop through mounting bracket (shown in green).

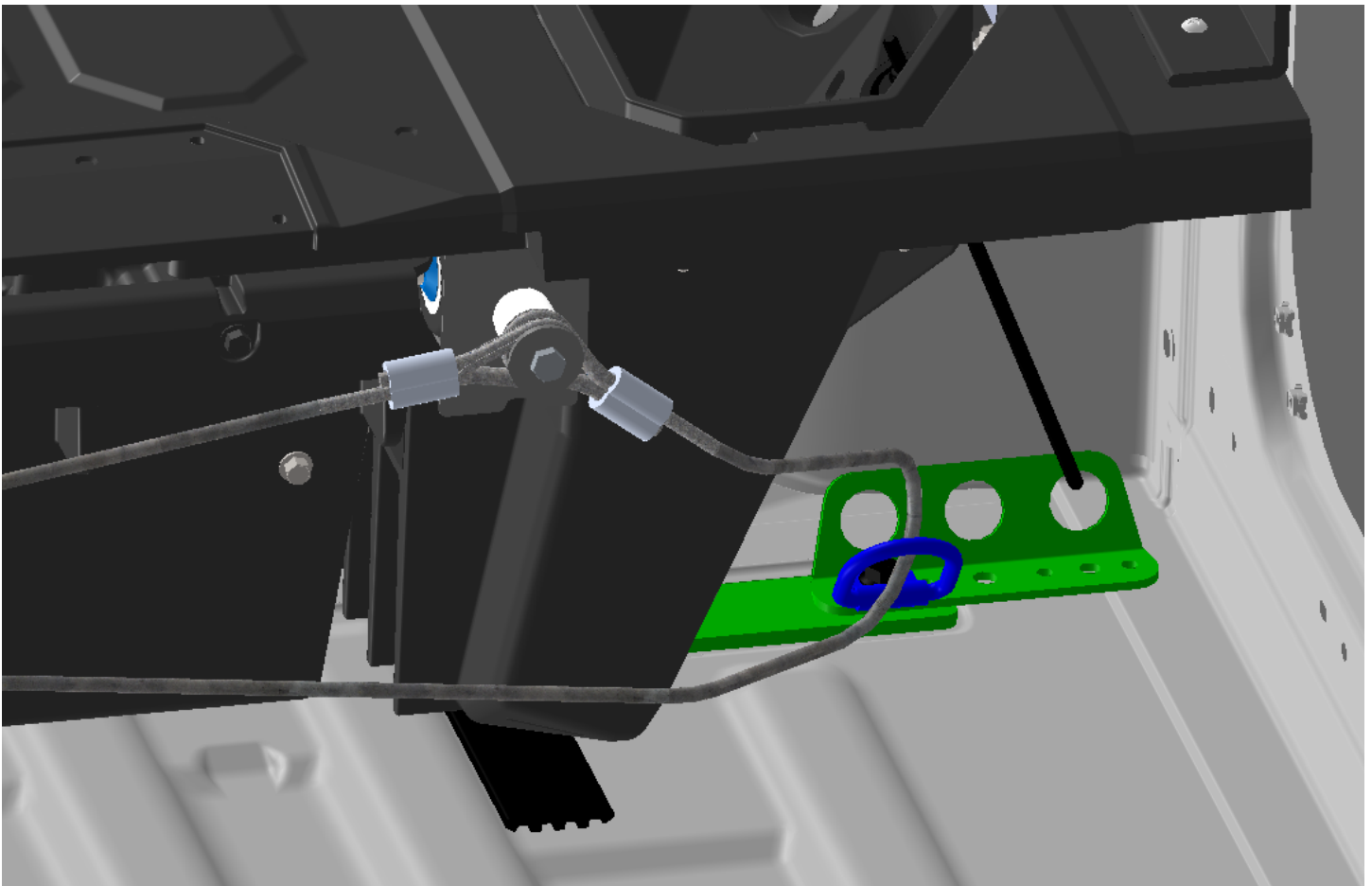

RETENTION CABLE INSTALLATION

Cable Installation – Step #3 –

Please note: the cables are of different lengths and marked LH & RH. The RH cable is longer.

- On the passenger side of the vehicle, loop RH cable eye thru cargo tie down ring (shown in blue in assembled view) on the cabside of the J-hook; **BAG VAN CABLE KIT**. Do not loop through mounting bracket (shown in green).
- Assemble LH and RH cable ends in the order depicted in the exploded view image, i.e. bolt thru washer, then thru LH cable eye and then RH cable eye, then thru 1 1/2" steel spacer, thru nylon spacer, thru hole in C-channel end plate and into nut; **BAG VAN CABLE KIT**.

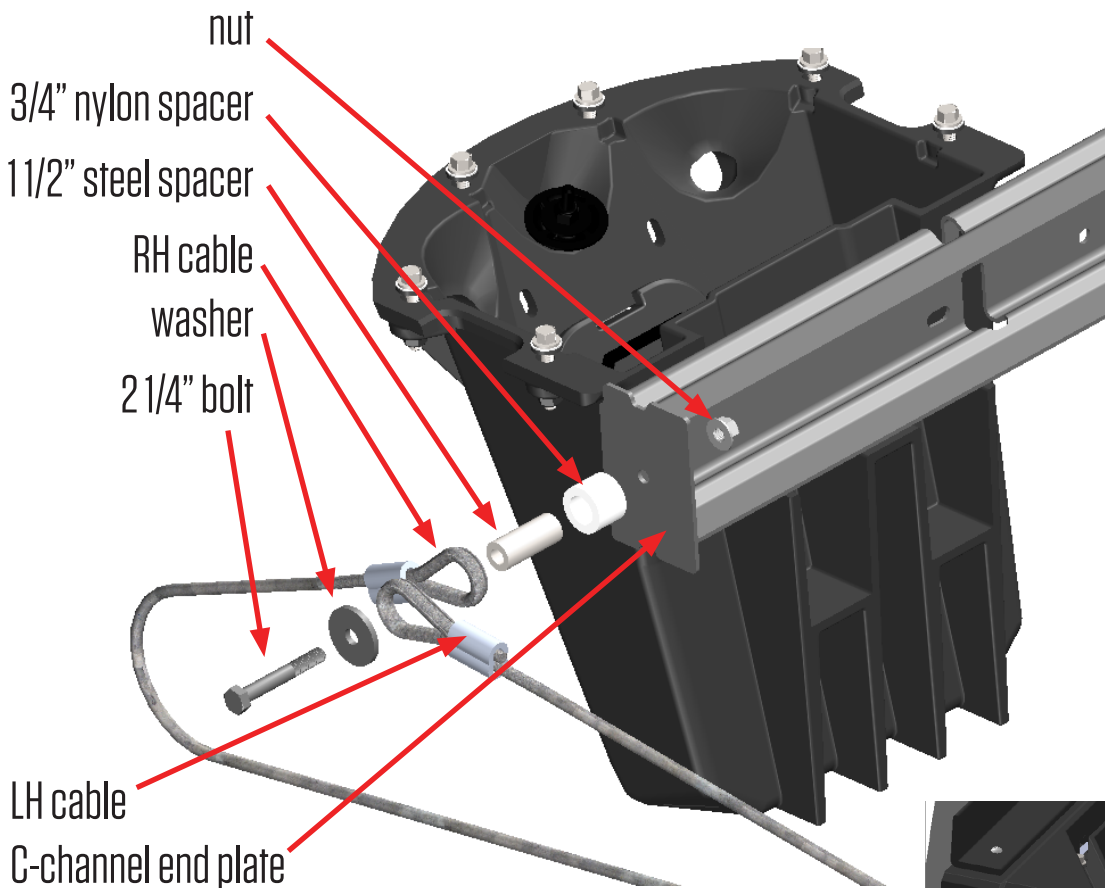

RECOMMENDED TORQUE:
Tighten to 25 ft-lbs.

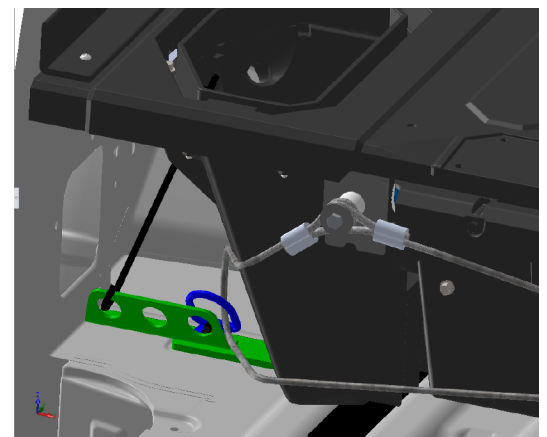

RETENTION CABLE INSTALLATION

Enlargement of RH cable assembly attachment to cargo tie down loop (shown in blue).
Do not loop through mounting bracket (shown in green).

