



DECKED Storage System



Installation Instructions:

DR6 & DR7

RAM 1500

(2019-CURRENT, NEW BODY STYLE ONLY)

TOOLS REQUIRED:

- 7/32" hex wrench
- 3/8" socket
- 1/8" hex wrench
- 7/16" socket
- 1/2" drill bit

INSTRUCCIONES EN ESPAÑOL:



INSTRUCTIONS EN FRANÇAIS :



IMPORTANT: If installing a CargoGlide on top of this drawer system, DO NOT install the drawer system into your truck yet - SEE INSTRUCTIONS.

Watch short installation videos at www.decked.com/video | Register your system at www.decked.com/warranty

FOLLOW US:



@DECKEDUSA | #DECKEDUSA

VERSION 10

DECKED.COM | 208.806.0251

K68622704

CONTENTS

www.mopar.com



HARDWARE box contents:

- C-CHNL - 1
- BOLTS L - 1
- CSAC - 1
- J6 RAM - 1
- DRAWER 1 - 1
- DRAWER 3 - 1
- HANDLE - 1
- WHEELS - 2
- PREP-EXTRA - 1
- BED TAPE - 1
- FOAM SEAL - 1
- FINAL FS - 1



BOTTLE OPENER - 1

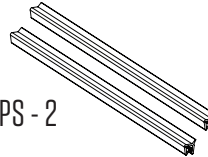

WEATHER STRIPS - 2

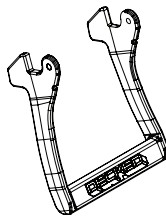

HANDLE - 1
(we installed one already)

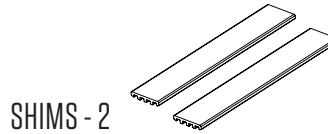

SHIMS - 2

▼ ASSEMBLY OVERVIEW ▼

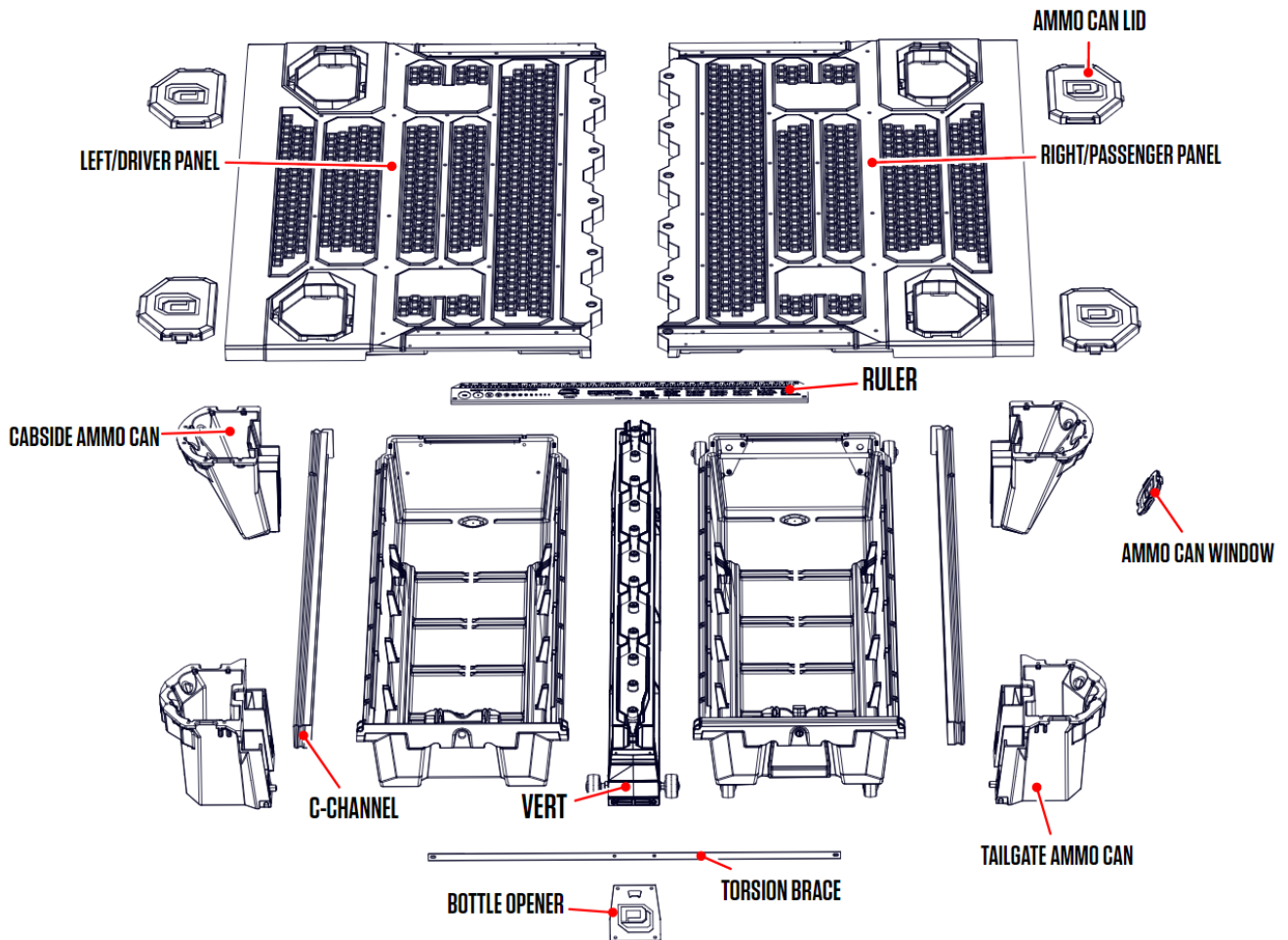

IMPORTANT: If installing a CargoGlide along with this drawer system, DO NOT install the drawer system into your truck yet - SEE INSTRUCTIONS.

▼ HEY! TORQUE BOY: READ BEFORE YOU INSTALL THE DECKED DRAWER SYSTEM ▼

- **DON'T** go rogue on us, please read the instructions.
- Start all bolts with your fingers to avoid cross-threading - you don't want to spin out any inserts.
- **DON'T** over tighten bolts, get em' hand-tight...or you will spin out the inserts.
- **DON'T** use power tools.
- If you don't follow directions and do use power tools, please set the clutch at a very low setting.
- Over-torquing or using an impact wrench will spin out the inserts - we're warning you!
- If you blow it, you can screw the inserts back in from the opposite side with a slotted screwdriver.
- If you really blow it, we've included some repair inserts in the PREP-EXTRA bag - install with a 7/32" hex wrench. Call us if you need more.
- You'll need a buddy for exactly two steps.
- Torque ratings are suggestions - tighten all fasteners until snug.
- Prevent expletive-filled language, watch our detailed installation video or give us a call. We're happy to help!

AMMO CAN DRAIN HOLES

(TO DRILL OR NOT TO DRILL.)

- **Do you use a tonneau or shell over your DECKED system?**
There is no need to drill holes, unless you leave your tonneau open in a deluge.
- **Does your DECKED system live outside?**
The ammo cans will get water in them. You'll need to drill holes in the ammo cans. There are two dimples in the bottom of each ammo can. Drill a 1/2" hole at each dimple. A smaller hole will get clogged. Depending on the system, we may have drilled these for you already.

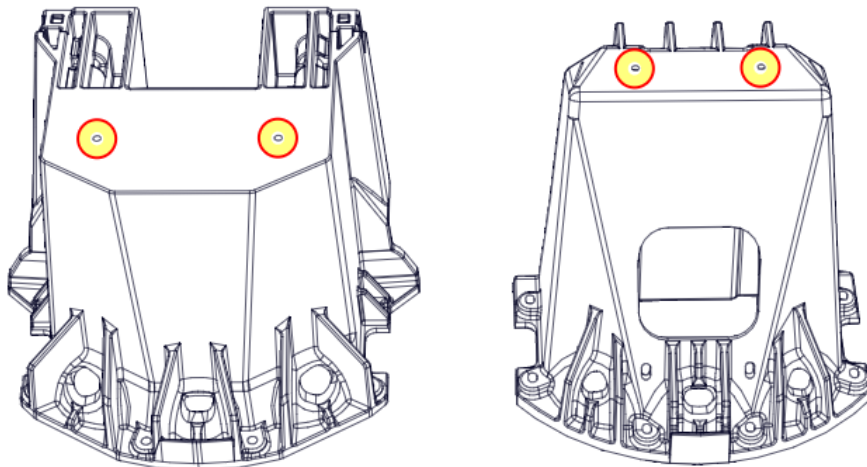

PREPARE BED: INSTALL BED TAPE

NOTE: Got a spray-in bed liner, Bedrug or mat? You won't need this bed tape. Otherwise, follow the directions below depending on your bed length to protect your bed paint.

DR6 - 5'7" BED:

- 1) Cut the tape into the following lengths for the 5'7" bed:
 - 12" long - 2 strips
 - 14" long - 4 strips
 - 61" long - 2 strips
- 2) Referencing the image **DR6** shown to the right:
 - a) Use isopropyl alcohol to clean the top surfaces of the floor beads where the tape will be located.
 - b) Remove film from tape to expose the adhesive surface.
 - c) Align the tape at the ends of the designated floor beads, center the tape on the flat, top surfaces and apply with pressure.

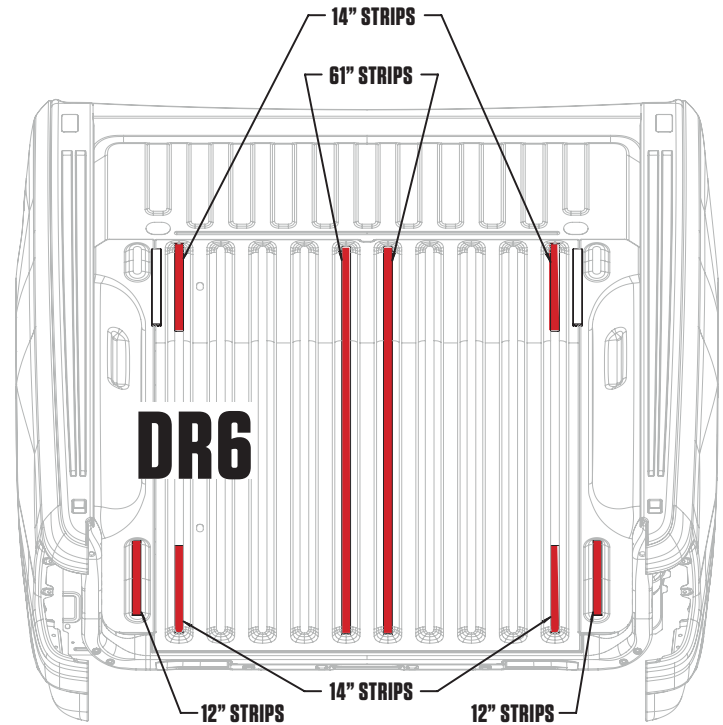

DR7 - 6'4" BED:

- 1) Cut the tape into the following lengths for the 6'4" bed:
 - 12" long - 2 strips
 - 14" long - 4 strips
 - 30" long - 4 strips
- 2) Referencing the image **DR7** shown to the right:
 - a) Use isopropyl alcohol to clean the top surfaces of the floor beads where the tape will be located.
 - b) Remove film from tape to expose the adhesive surface.
 - c) Align the tape at the ends of the designated floor beads, center the tape on the flat, top surfaces and apply with pressure.

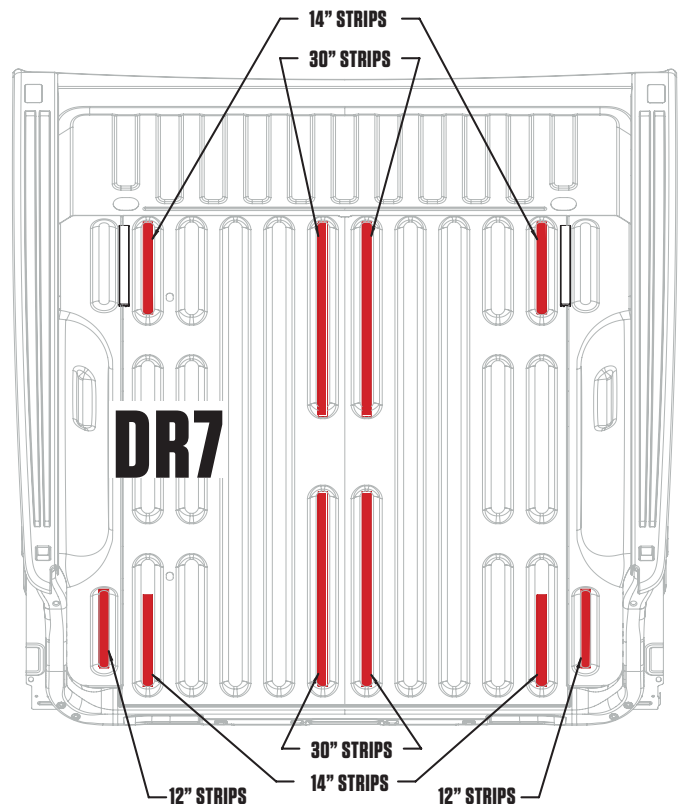

PREPARE BED: INSTALL SHIMS

- There are **2 SHIMS** provided:
- Using the information in the respective circular detail views:
- Clean the surfaces thoroughly where the shims will be located (isopropyl alcohol is recommended).
- Remove the layer of tape on the bottom of the shim to expose the adhesive surface.
- Place the shim and apply with pressure.

NOTE: Repeat DETAIL A passenger side.

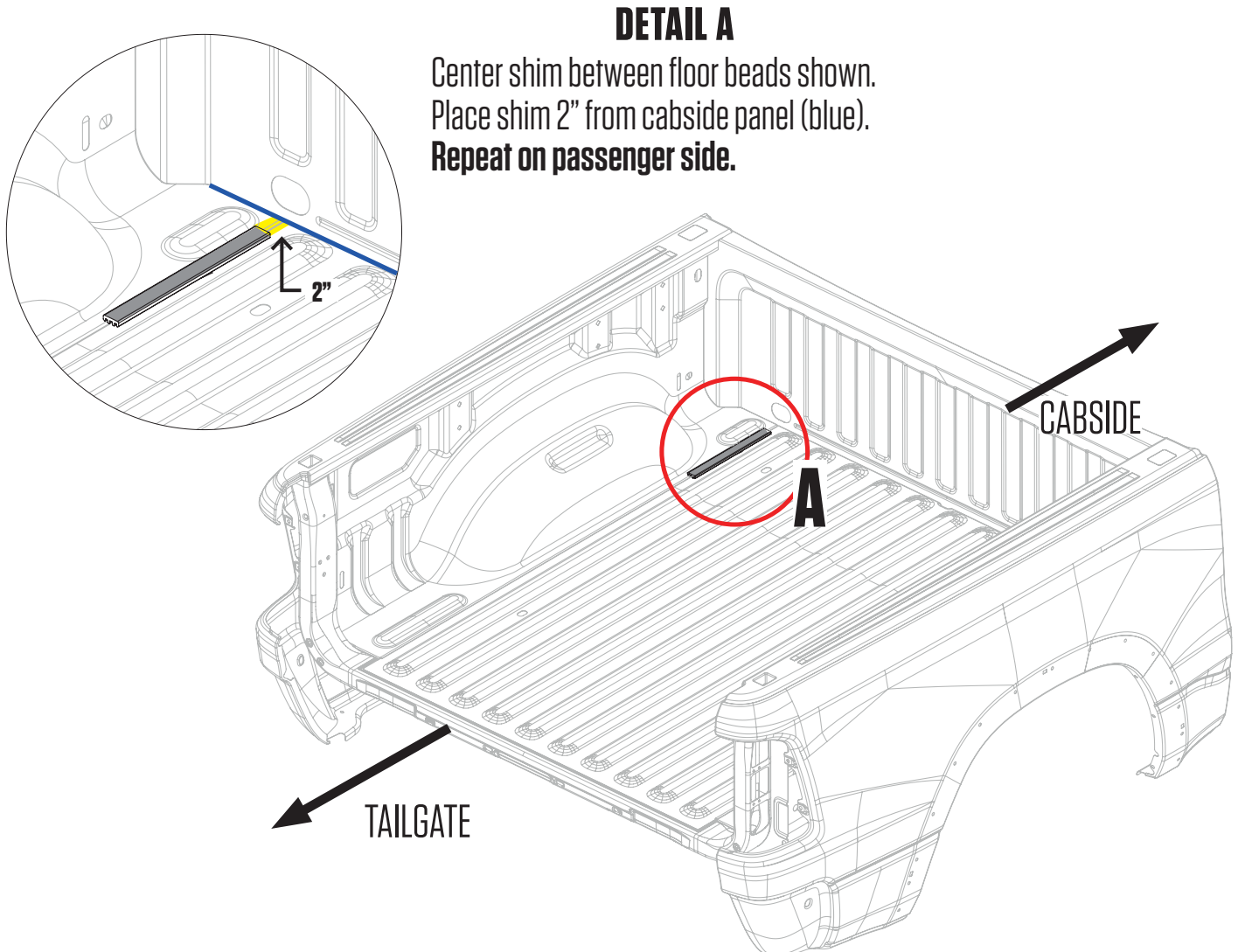

ASSEMBLY

LAY IT OUT:

(Now the fun begins!)

- Arrange all components on a flat surface as shown, not in your truck.
- Make sure all wheel axles we installed for you are on the tailgate side.
Read this again. Don't mess this up.
- Place the C-channels on the ledges of the ammo cans.
- The C-channel end plates must be on the cabside of the assembly.

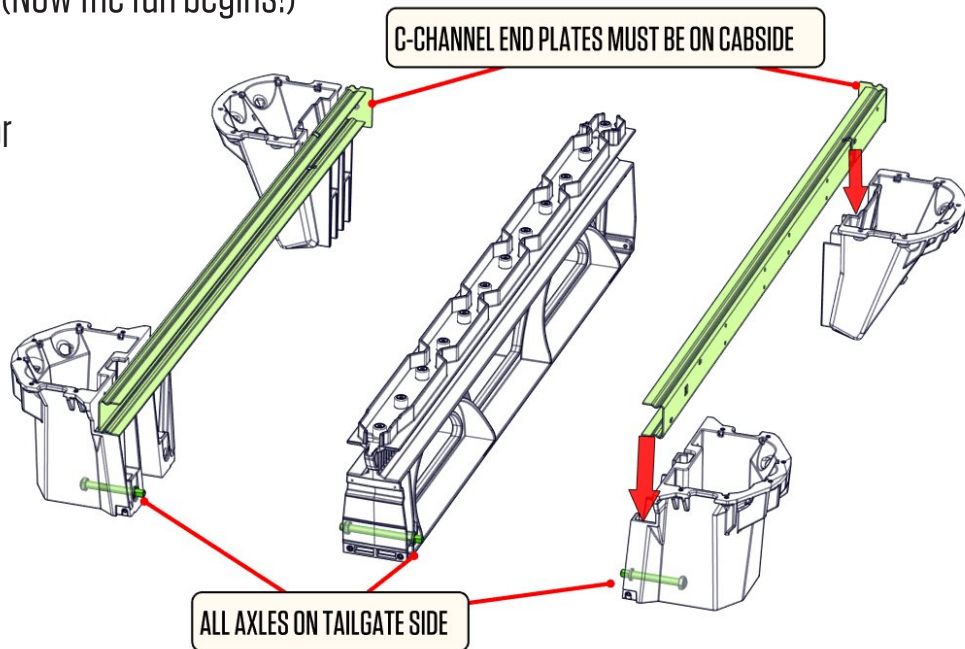

HOOK IT UP:

Grab your bag: **C-CHNL**

- Install a 1" black bolt from the **INSIDE** of the C-channel and into any ammo can.
- The bolt head must be on the C-channel side. That was important.
- Fasten with flanged nut on the inside of the ammo can, but do not tighten.
- Repeat same procedure for the other three ammo cans. Don't tighten. Each ammo can will need two bolts.

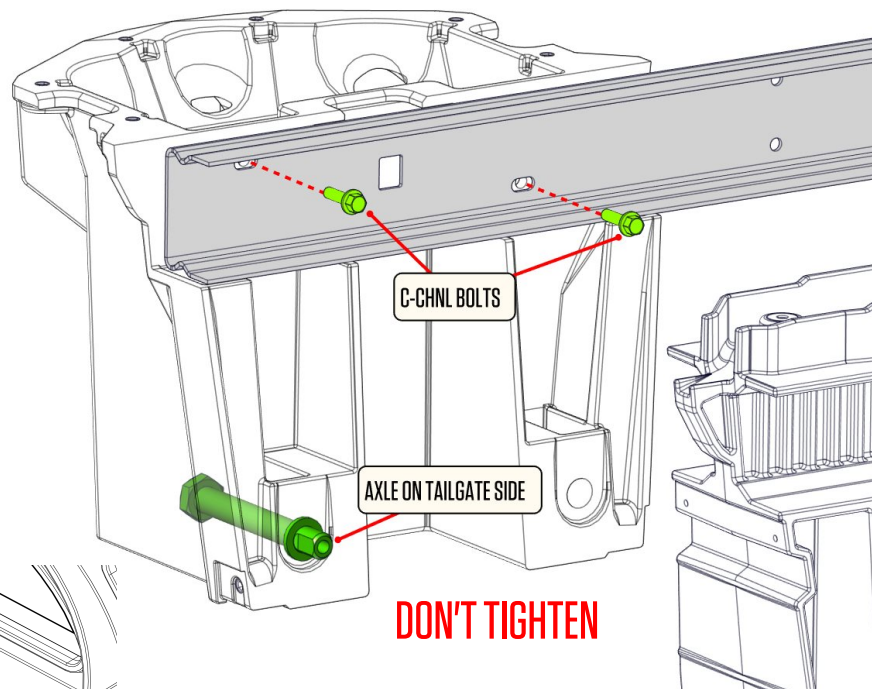
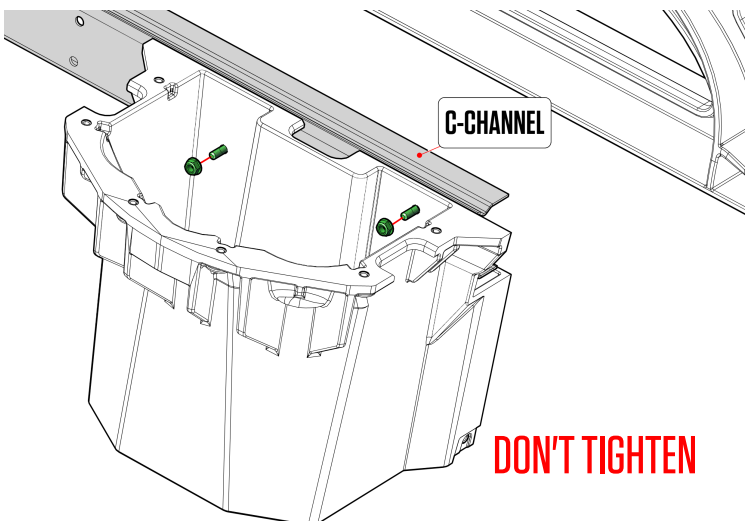

Note: 4 things you could have messed up:

1. C-channel bolt heads are inside ammo cans and not C-channels - wheels ain't gonna roll.
2. Wheel axles on ammo cans and vert aren't all the way at the tailgate side - wheels ain't gonna install in the correct spot.
3. C-channel end caps are on the tailgate side - things ain't gonna fit.
4. You tightened the C-channel to ammo can bolts when I told you not to.

LAY IT ON:**GET YOUR DECK ON**

Grab your bag: **CSAC, BOLTS L**

- Seat the passenger side deck on the vert and the ammo cans. You may have to move the ammo cans around a bit. The panel label must be on the TAILGATE side.
- Use six (6) of the **CSAC** bolts and flanged nuts to install the deck to the **CABSIDE** ammo can - the one with the window. Tighten until snug, 27 in-lb. **DETAIL A.**
- There are two kinds of bolts in the **BOLTS L** bag. Some are plain stainless and some have a blue coating applied under the bolt head. Use the correct bolts as outlined in each step
- Use six (6) of the blue-coated **BOLTS L** bolts to install the deck to the inserts in the tailgate ammo can - no nuts here. Tighten until just snug, 27 in-lb. **DETAIL B.**
- Use the plain stainless **BOLTS L** bolts to install the passenger side deck to the center vert. **DETAIL C.**

Remember what we said about power tools?

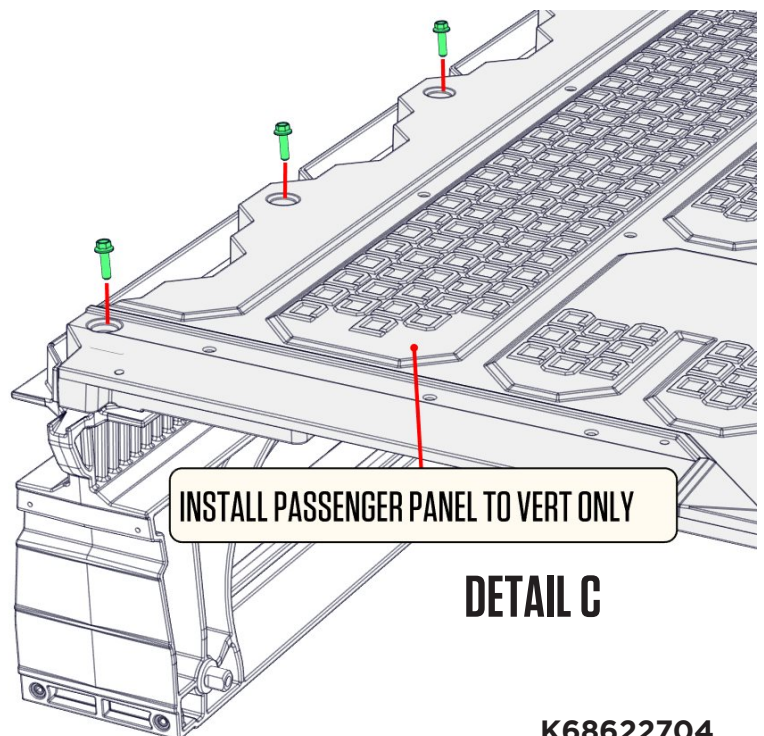
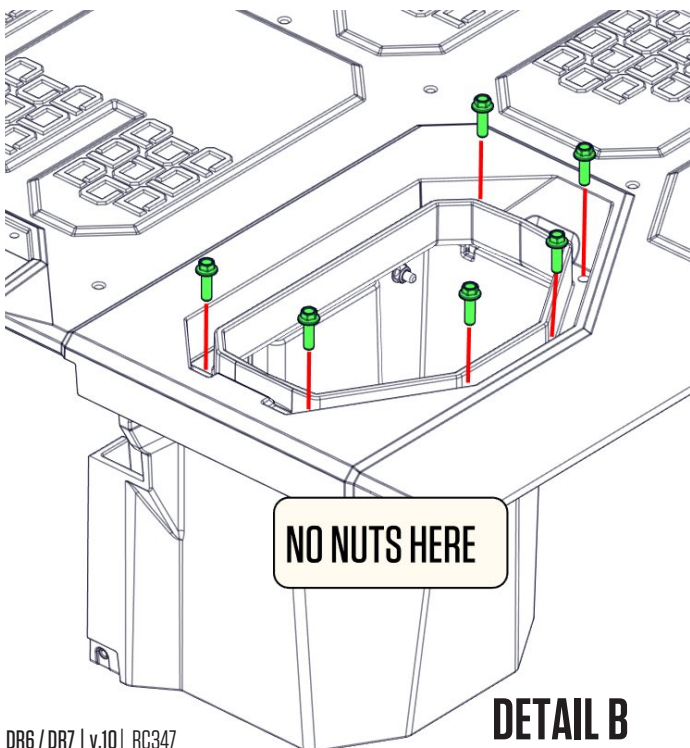
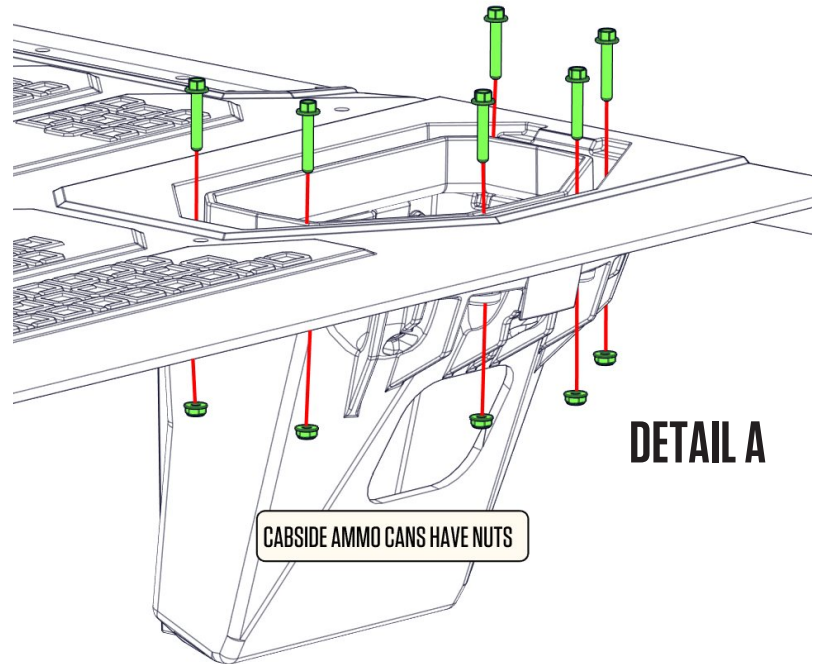
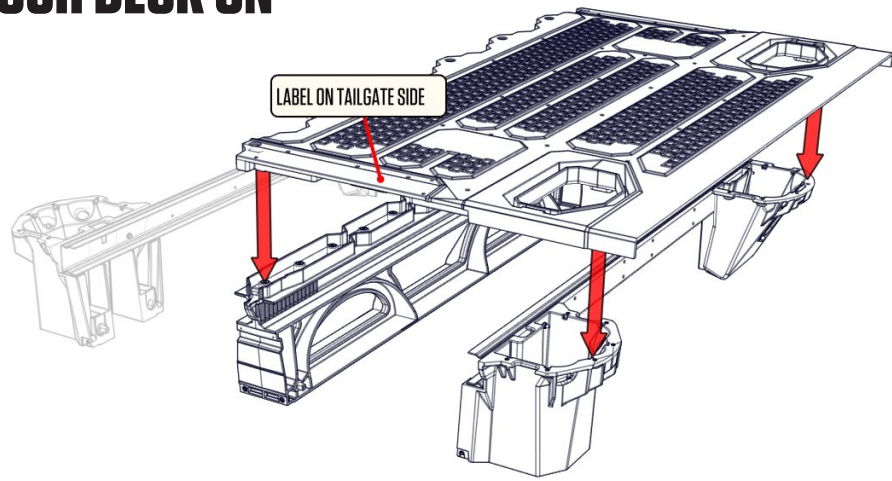

GET THE REST OF YOUR DECK ON

- Seat the driver side panel on the ammo cans and center vert.
- Attach the panel to both ammo cans, repeating the steps from the previous page.
- Do not attach the driver side panel to the center vert. Do I have to repeat myself?
- Now you can tighten the eight (8) C-channel to ammo can bolts. Don't forget unless you like rattles.

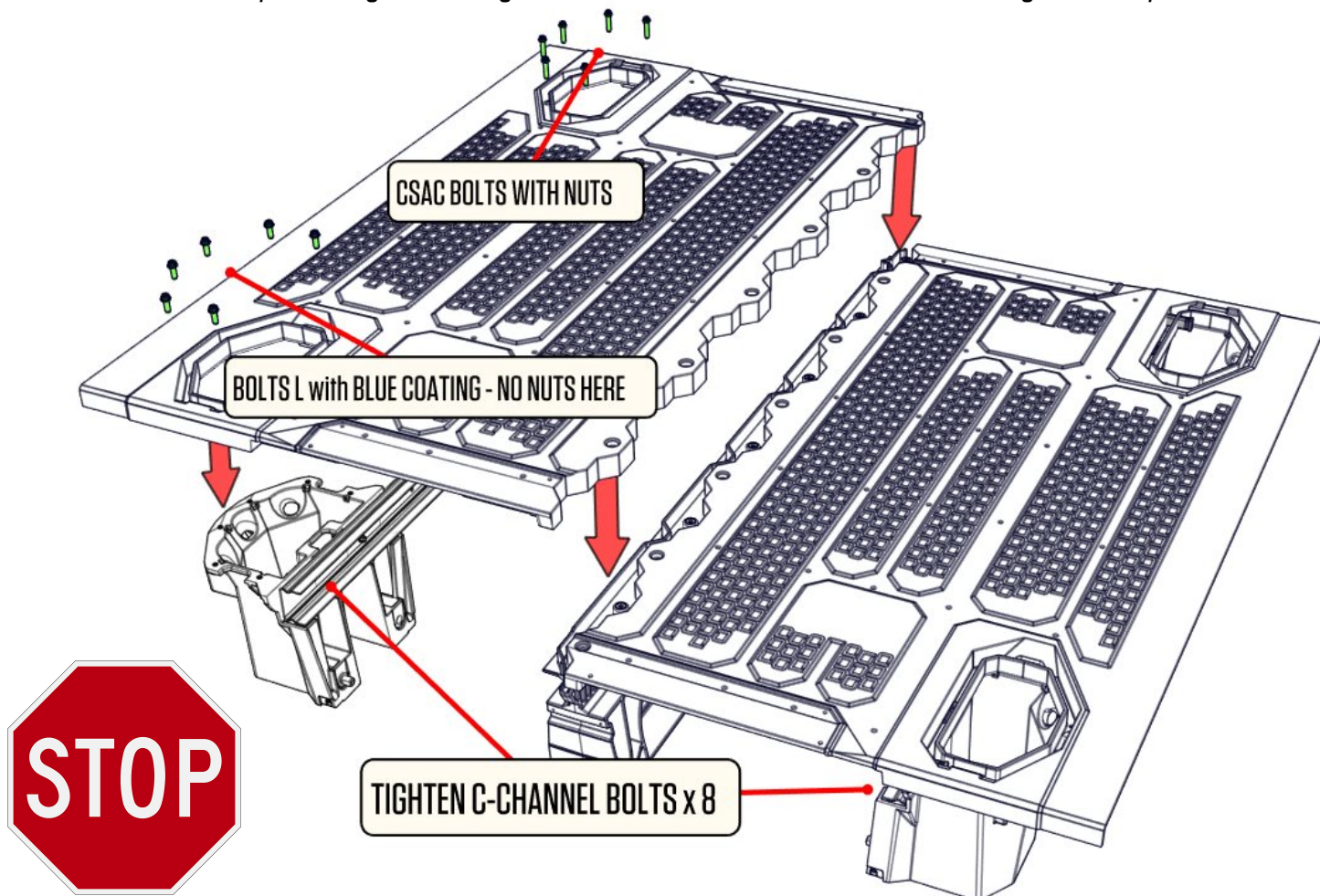

If you will be installing a CargoGlide onto the DECKED drawer system, now is the time to grab your CargoGlide instructions in order to prepare the panels. Do not put the drawer system in your truck. Continue with the following instructions if you will not be installing a CargoGlide unit.

- Gently remove the driver side assembly from the vert and put aside. If you attached the driver side panel to the vert, see the third bullet above, smack your hand and carefully remove the bolts.
- Find a friend to help you lift and place the passenger side assembly into the bed of your truck. Nicely ask the same friend to lift and place the driver side assembly into the bed and seat the panel onto the center vert.
- Install the driver side panel to the center vert using the plain stainless BOLT L bolts. 27 in-lb.

INSTALL: CABSIDE FOAM SEAL

NOTE: You won't need this seal if you have a tonneau cover or camper shell.

- Standing at the tailgate end of the bed, grab deck panels and pull the whole system as far toward the tailgate end as possible.
- Climb up on deck and place foam seal in the gap between the deck and cabside panel with the adhesive side facing the deck, not the truck, as shown in **DETAIL A**. The top edge of foam seal should be level with the top edge of the deck. **NOTE: Depending on how the seal is unrolled, the paper carrier may not end up on the adhesive side of the seal. Check for stickiness in determining the adhesive side of the seal.**
- Slowly stick the foam seal across the deck panel and remove the paper carrier as you go.
- Once foam seal is in place, stand at tailgate end of bed and push the DECKED system as far towards the cab as possible to compress the seal.

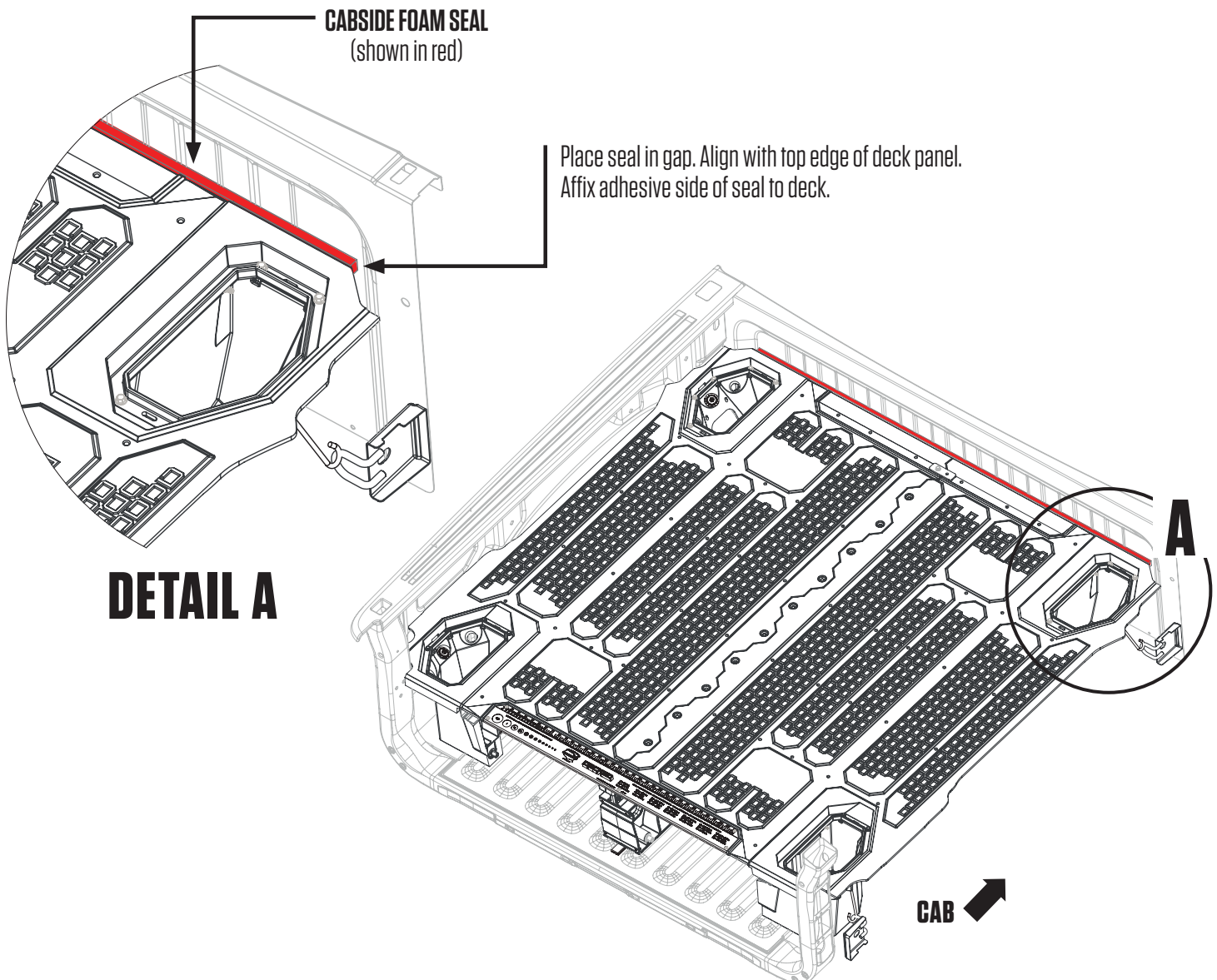

DRAWERS: BRACKETS + WHEELS

(EASIER THAN FALLING OFF A LOG)

Grab your bag: **DRAWER 1/DRAWER 3/WHEELS**

- Each drawer has a left and a right wheel bracket. Place the brackets into the drawers as shown.
- Install two 3/4" bolts into the bottom two bracket holes. Secure with nuts. Leave loose for now. **DETAIL A.**
- Install the 2" bolt into the back mounting hole where shown. Secure with a nut. 27 in-lb. **DETAIL A.**
- Tighten bottom two bolts. 27 in-lb.
- Use two 3/4" bolts to install the tube brace. 27 in-lb. **DETAIL B.**
- Install the wheels with a 7/32" hex wrench. 90 in-lb. **DETAIL C.**

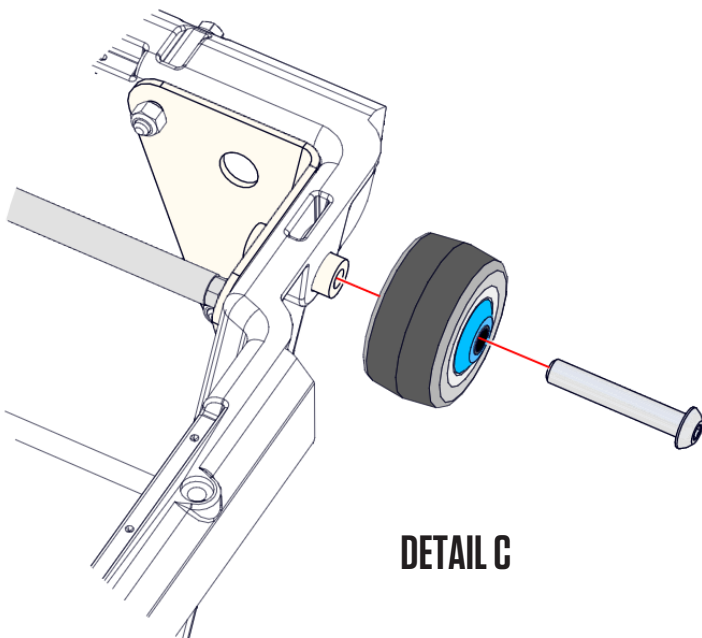
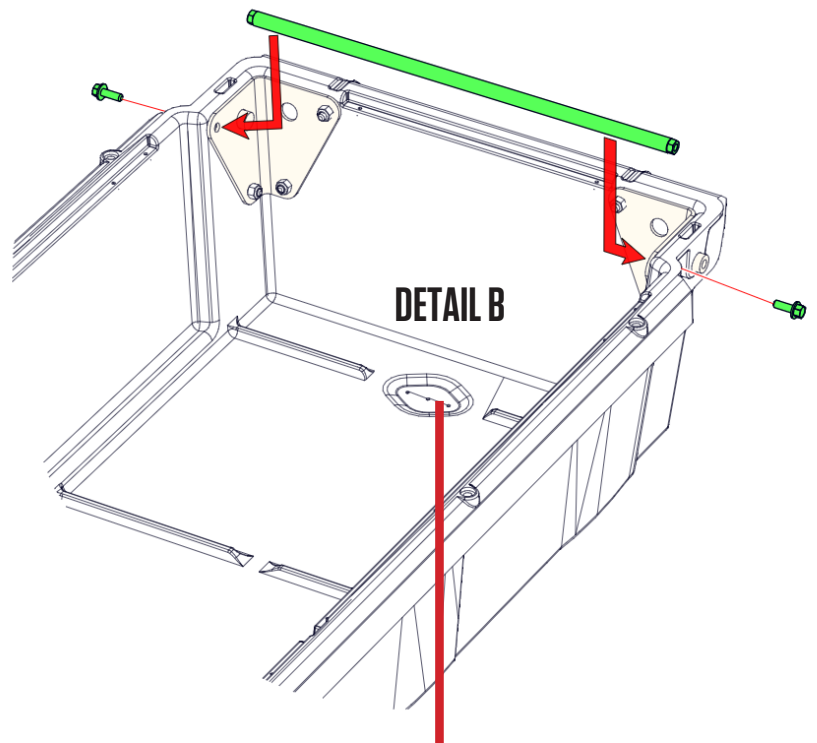
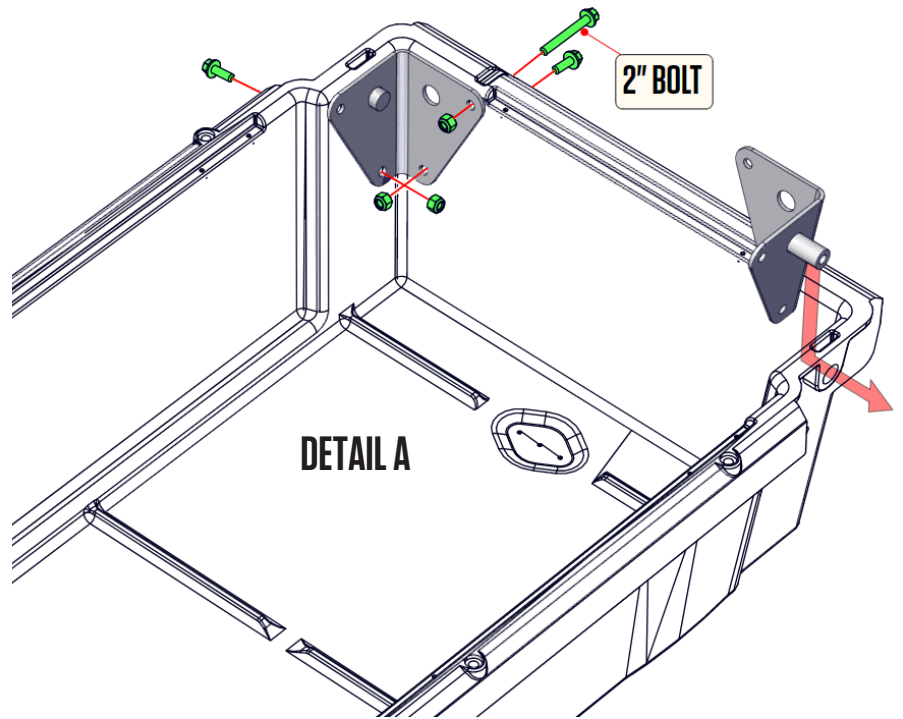

HELPFUL TIP: If you purchased drain plugs, install now (instructions are included with drain plugs).

INSTALL: DRAWER HANDLE

Grab your bag: **HANDLE**

- OK, Sparky, one drawer handle assembly needs to be installed by you. We did the other one. Save yourself the headache, watch this short installation video: **DECKED.com/videohandle**.
- From the front face of the drawer, place the springs up and into the cavities on either side of the handle slots, red spring=right spring.

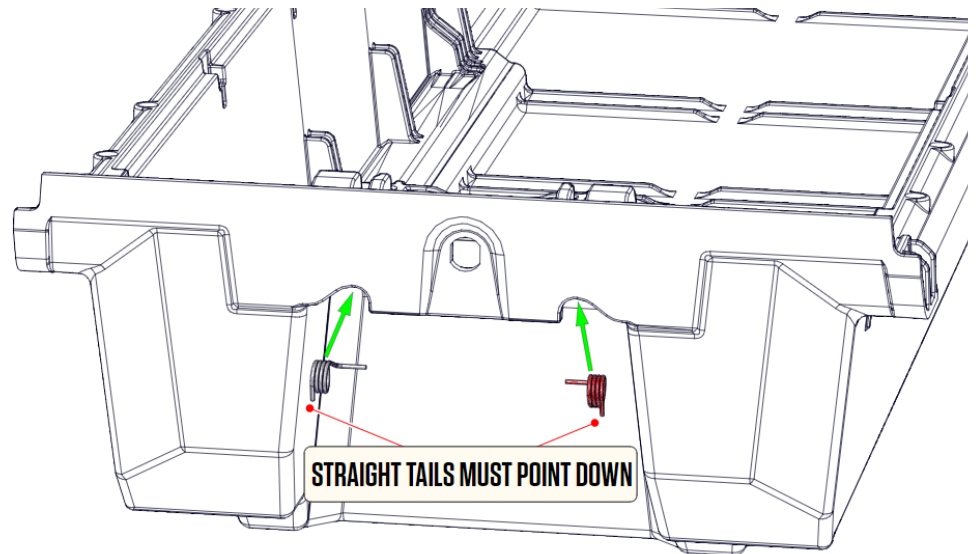

NOTE: Each spring arm should point inward, with the straight tails facing you and pointing down.

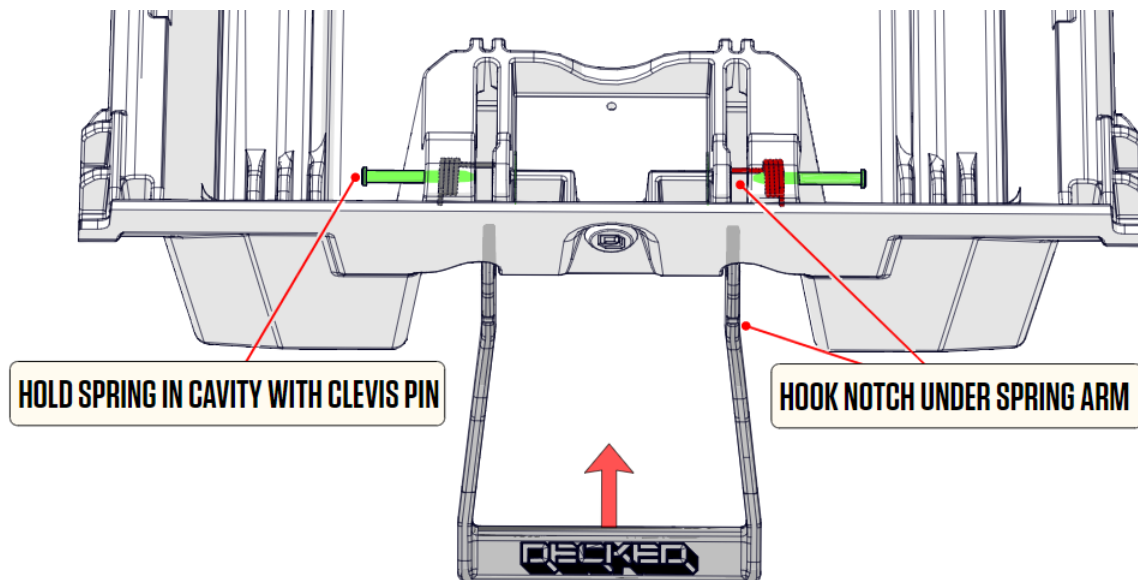

- Install a clevis pin through each outside drawer hole and through the spring.
- With the DECKED logo facing outward, insert the handle ends behind the spring arms. Hook the spring arms into the handle notches and rotate the arms of the handle toward the clevis pins, which will pull the spring arm downward.
- When the handle hole is aligned to the clevis pin, push the pin through the handle hole and through the inside drawer hole. Repeat on the other side of the handle.
- Install a hair pin through the clevis pin.

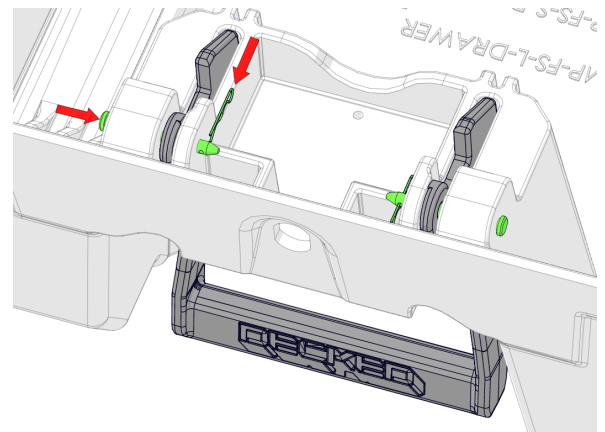

INSTALL: DRAWERS

Grab your bag: **WHEELS**

- Save yourself the headache, watch this short installation video: [DECKED.com/video/tailgatewheels](https://www.decked.com/video/tailgatewheels).
- Install the drawer by sliding wheels into their two channels (C-channel and center vert), and slide drawer all the way forward until closed.
- Install the remaining tailgate side wheels onto their axles. 90 in-lb. Install the weatherstrips **AFTER** you install the wheels. **NOTE: Placing a spacer under the drawer to raise it into position makes this easier (ammo can lids work well, or a small piece of 2x2 or 2x4).**
- Install the weather strips on the tailgate side drawer edge: With the weatherstrip wiper facing cabside, line up one end with the side of the drawer and place on the top drawer edge, firmly pressing down on the weatherstrip as you move along the drawer edge. **NOTE: Facing the weather stripping the wrong way will funnel water into drawer: BAD!**

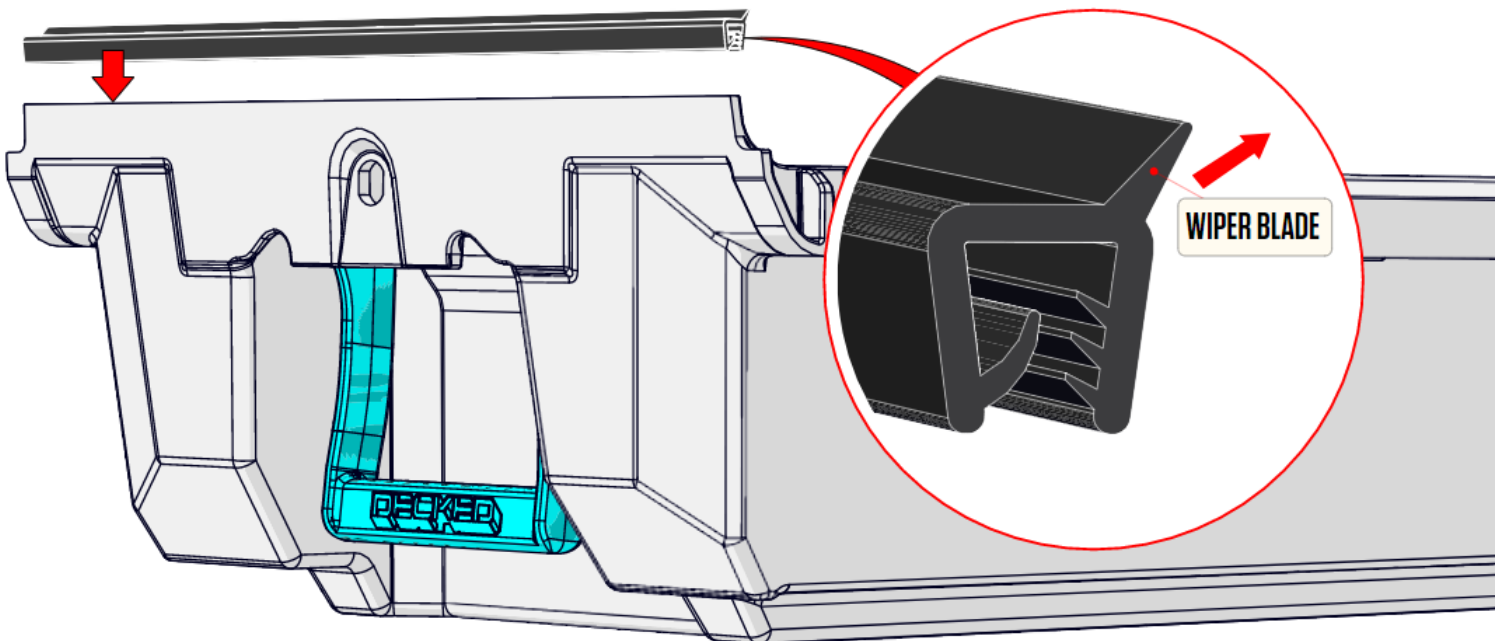
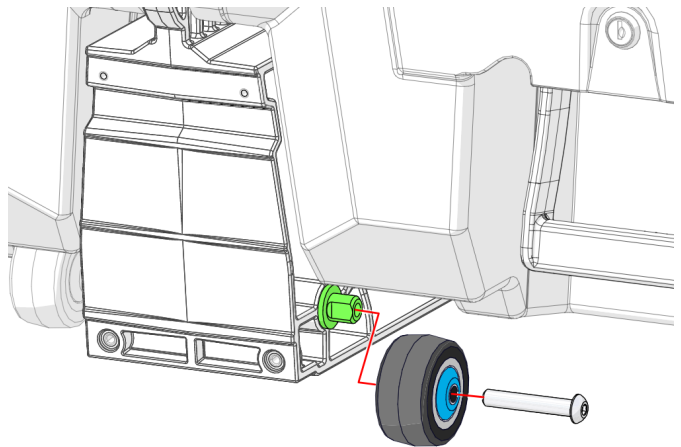
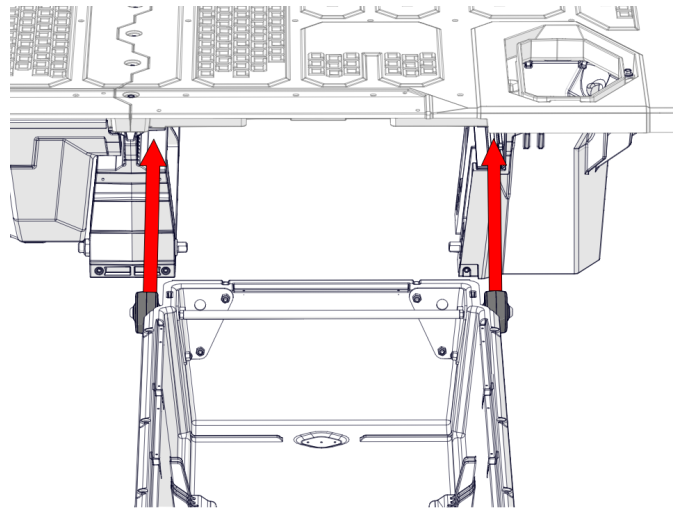

INSTALL: THE FUN STUFF

Grab your bag: **FINAL FS**

- Slide the torsion brace under the center vert and tailgate ammo cans. The side without the holes slides UNDER the center vert and tailgate ammo cans.
- Place bottle opener on the outside of the torsion brace.
- Loosely install (start with your fingers to avoid cross-threading):
 - Two 1/2" black bolts through the upper holes in the bottle opener into the center vert - leave loose.
 - Two 1" black bolts through the bottom bottle opener holes and torsion brace into the center vert inserts - leave loose.
 - Two 1" black bolts through the end holes in torsion brace into the tailgate ammo can inserts - leave loose.
- Align bottle opener to edges of center vert and tighten the four bottle opener bolts.
- Tighten end bolts into tailgate ammo cans.
- Install lock core plugs into the drawer lock holes or install locks if purchased. (Instructions included with locks)
- Align the ruler plate on the tailgate end of the panels. Use an 1/8" hex wrench to install the six ruler screws into the panel inserts - do not overtighten these.

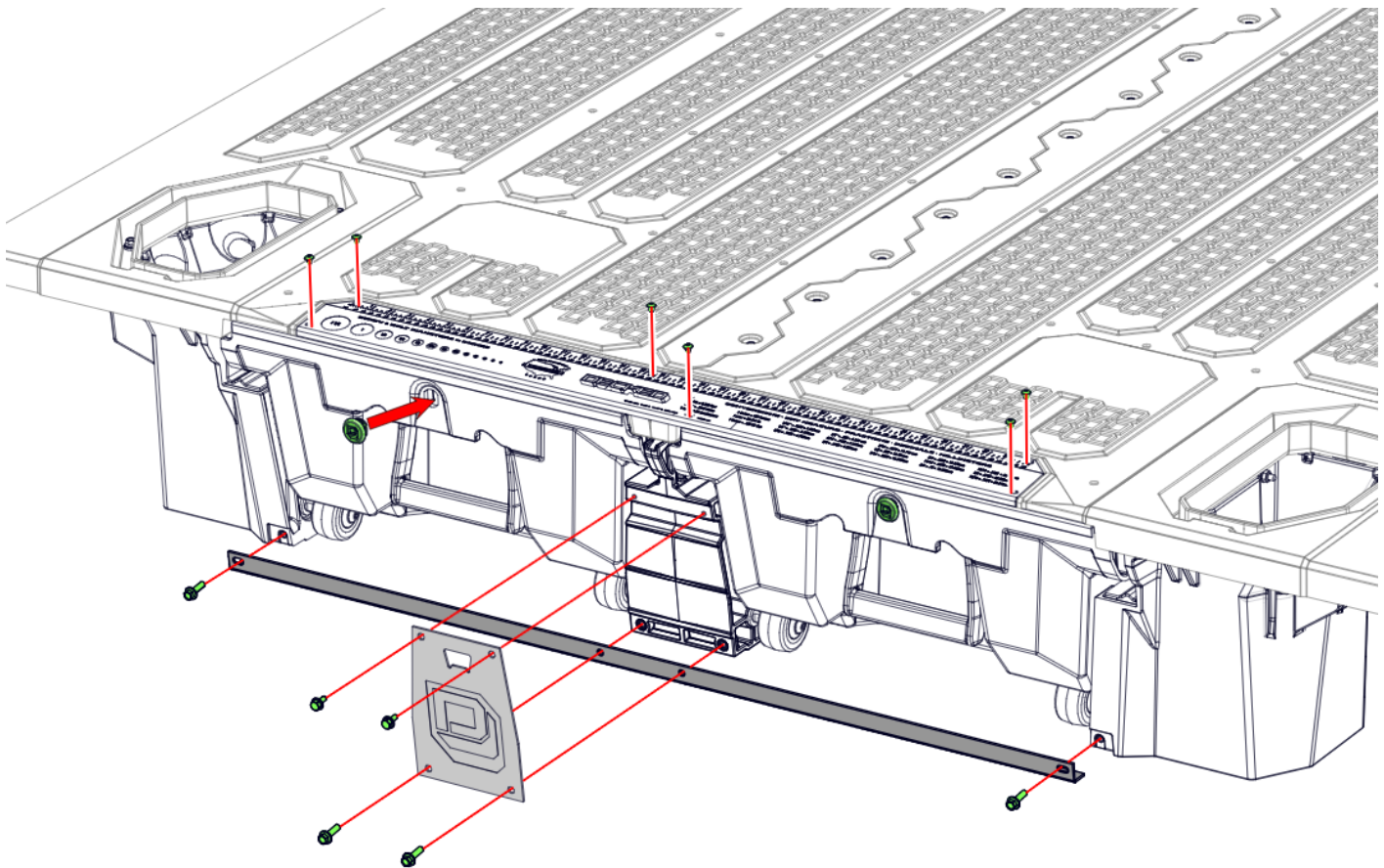

HELPFUL TIP: Bottle opener goes on the **outside** of the torsion brace.

#DECKEDUSA | @DECKEDUSA

K68622704

TIGHTEN: J-HOOKS/INSTALL AMMO CAN WINDOWS AND LIDS

Grab your bag: J-6C, FINAL FS

- Insert the J-hook through the **center** hole on the passenger side tailgate ammo can and loop J-hook through tie down or mounting bracket in bed. Screw on the winged-spherical nut-washer, round side down, on the J-hook and fasten until finger tight, but don't tighten all the way yet.
- Don't tighten yet. If you do, you won't be able to center the system properly in your bed.
- Insert the J-hook through **center** hole on the passenger side cabside ammo can and loop J-hook through tie down or mounting bracket in bed. Screw on the winged-spherical nut-washer, round side down, on the J-hook and fasten until finger tight. Don't tighten yet.
- Verify that the bottle opener is centered above a bed rib/valley.
- Gradually and alternately tighten all four J-hooks until you can't wiggle the j-hooks and the system does not move in the bed. Do not overtighten! **DETAIL A.**
- Install thread bolt protectors on J-hook ends.
- Orient the "D" on the ammo can window as shown. Engage the bottom tab into the ammo can window and push the top tab into place.
- Install the ammo can lids. **DETAIL B.**

DRIVER SIDE
CABSIDE AMMO CAN

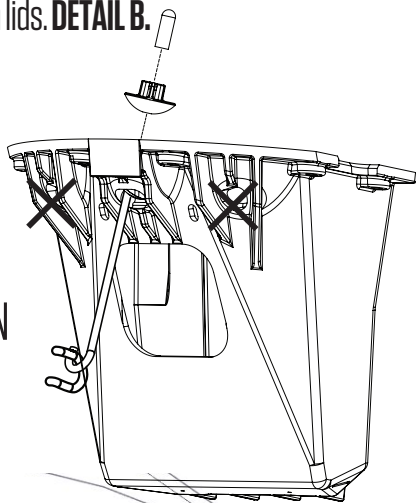

DRIVER SIDE
TAILGATE AMMO CAN

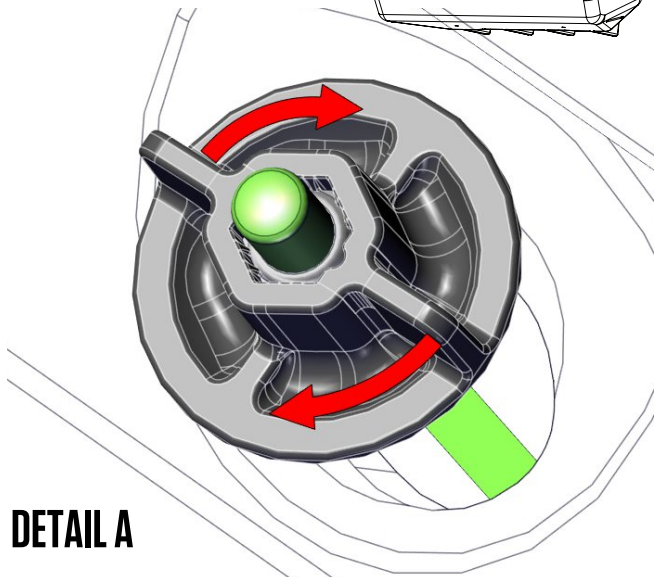
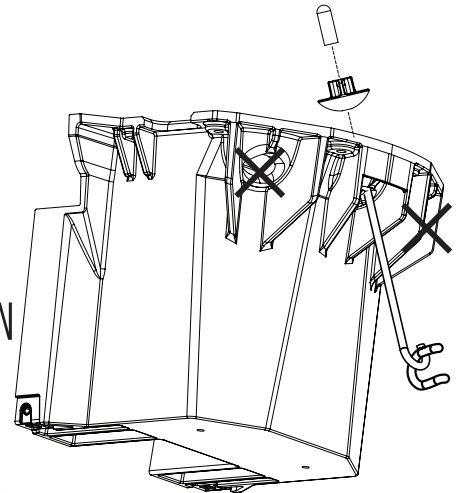

DETAIL A

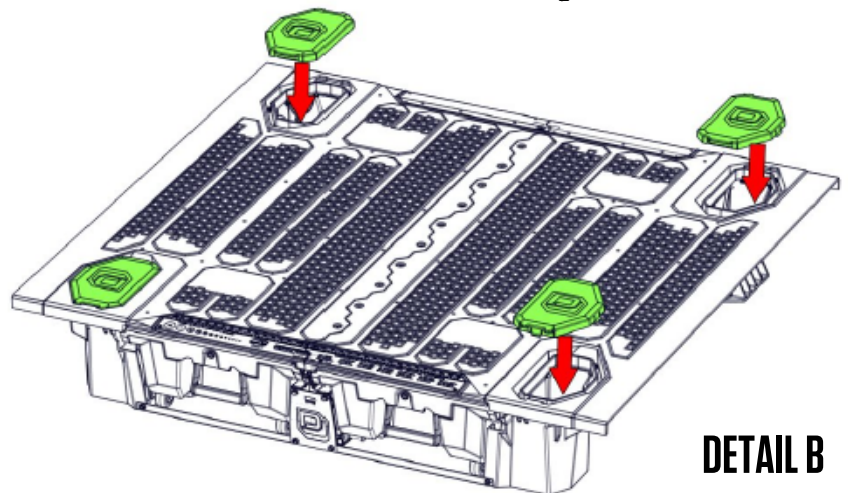

DETAIL B

IMPORTANT: Grab your favorite beverage, crack 'er open in the bottle opener and make a toast to your van. You did it. Immediately post a photo of your significant other, child or canine (in no order of significance - please someone show us your pet alligator) appreciating your accomplishment. Add hashtag #DECKEDUSA | @DECKEDUSA.

DECKED Products – Limited Lifetime Warranty

(Valid on DECKED Products purchased on or after 8/1/2021)

DECKED LLC, (the “Manufacturer”) warrants the original purchaser only that DECKED Truck and Van Products (The “DECKED” Product) will be free from defects in material and workmanship from the date of purchase and continuing for the expected lifetime of the DECKED Product. The DECKED Product must be registered by the original purchaser with DECKED, LLC via its website at, www.decked.com/register, and a copy of the original sales receipt must be supplied to the Manufacturer at the time a warranty claim is made. This warranty terminates if the original purchaser transfers the DECKED Product to any other person or vehicle.

WHAT IS COVERED

All DECKED Products identified above on or after August 1, 2021

DECKED's Limited Lifetime Warranty applies to US and Canadian customers only. International shipments are covered by DECKED's 3 Year Limited Warranty.

WHAT WE WILL DO TO CORRECT PROBLEMS

Subject to the limitations and exclusions described in this limited warranty, the Manufacturer will remedy defects in workmanship or materials by providing one of the following remedies at its option and without charge to the original purchaser for parts: (a) repairing the defective portion of the DECKED Product or (b) replacing the entire DECKED Product. In addition, the Manufacturer may elect at its option not to repair or replace the DECKED Product, but rather issue to the original purchaser a refund equal to the purchase price paid for the DECKED Product or a credit to be used towards the purchase of a new DECKED Product.

WHAT IS NOT COVERED

This limited warranty expressly excludes:

- Damage or defects caused by normal wear and tear, cosmetic rust, scratches, accidents, unlawful vehicle operation, installation in a non-supported vehicle or installed in a vehicle which does not match the DECKED Product's SKU-intended fitment or use, or modification of the product, or any types of repair of a DECKED Product other than those authorized or provided by the Manufacturer.
- Damage or defects resulting from conditions beyond the Manufacturer's control and specifications including, but not limited to modification, misuse, overloading, or failure to assemble, install or use the DECKED Product in accordance with the Manufacturer's written instructions or guidelines included with the DECKED Product or separately made available to the original purchaser.
- Damage to the contents of the DECKED Product or vehicle.
- TO THE EXTENT PERMITTED BY LAW, IN NO EVENT SHALL THE MANUFACTURER BE LIABLE FOR ANY INCIDENTAL, SPECIAL, INDIRECT, OR CONSEQUENTIAL DAMAGES, INCLUDING ECONOMIC LOSS, WHETHER RESULTING FROM NONPERFORMANCE, USE, MISUSE, OR INABILITY TO USE THE DECKED PRODUCT OR THE MANUFACTURER'S NEGLIGENCE.

NO OTHER EXPRESS WARRANTY APPLIES

This Limited Lifetime Warranty is the sole and exclusive warranty for DECKED Products. No employee, agent, dealer, or other person is authorized to alter this warranty or make any other warranty on behalf of DECKED LLC.

NOTIFICATION PROCEDURES

If the DECKED Product does not conform with the terms of this limited warranty, the original purchaser must promptly notify the Manufacturer in writing upon discovery of the nonconformity. In order to receive remedies under this limited warranty, a warranty claim must have been registered with DECKED LLC by the original purchaser, must describe the nature of the products nonconformity, include a copy of the original sales receipt, invoice, or other proof of purchase and be accompanied with photos or video. Repairs or modifications made to the DECKED Product by other than the Manufacturer or its authorized agent will nullify this limited warranty. Coverage under this limited warranty is conditioned at all times upon the owner's compliance with these required registration, notification, and repair procedures.

Product registration may be performed at: <https://decked.com/register>

Warranty claims must include reciprocal contact information and may be made via certified mail or email to:

DECKED Warranty and Claims

Contact info:

DECKED LLC

PO Box 885

Ketchum, ID 83340

warranty@decked.com

208-806-0251

DR6 / DR7 | v.10 | RC347

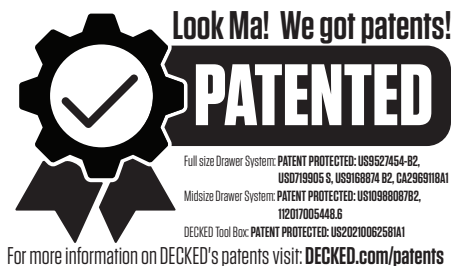

K68622704