



Installation Instructions:

MV1 2010-2017 ANZ / 2010-2016 EUR

MV3 2018-CURRENT ANZ / 2017-CURRENT EUR

VW AMAROK DUAL 1555mm BED LENGTH

TOOLS REQUIRED



REGISTER YOUR SYSTEM

- 7/16" socket
- T40 Torx driver
- 1/4" drive ratchet
- 1/8" hex wrench
- electric drill
- 11mm drill bit
- 13mm drill bit
- drill stop
- Depending on truck year, you will need a 12 point M10 socket -or- a 12 point M10 bit



INSTRUCTION VIDEOS

Watch short installation videos at www.decked.com/video | Register your system at www.decked.com/warranty

FOLLOW US:      @DECKEDUSA | #DECKEDUSA

VERSION 8

DECKED.COM | 208.806.0251

RC249

CONTENTS

DECKED carton

- LEFT DECK HALF - 1
- RIGHT DECK HALF - 1
- CENTER VERT - 1
- CABSIDE VERT - 1
- DRAWER - 2
- LEFT AMMO CAN - 1
- RIGHT AMMO CAN - 1
- LEFT STUD - 1
- RIGHT STUD - 1
- AMMO CAN LID - 2
- C-CHANNEL - 2
- RULER - 1
- HARDWARE BOX - 1
- TORSION BRACE - 1
- BOTTLE OPENER - 1

Hardware box - unbagged components

(inside DECKED carton):



HARDWARE box - bagged components

- PREP MV1/MV3 - 1
- S1 - 1
- S2 - 1
- N1 - 1
- J8 - 2
- DRAWER 1 - 1
- DRAWER 2 - 1
- WHEELS - 1
- FINAL MID - 1
- PREP-EXTRA - 1
- WASHERS - 1

ASSEMBLY OVERVIEW

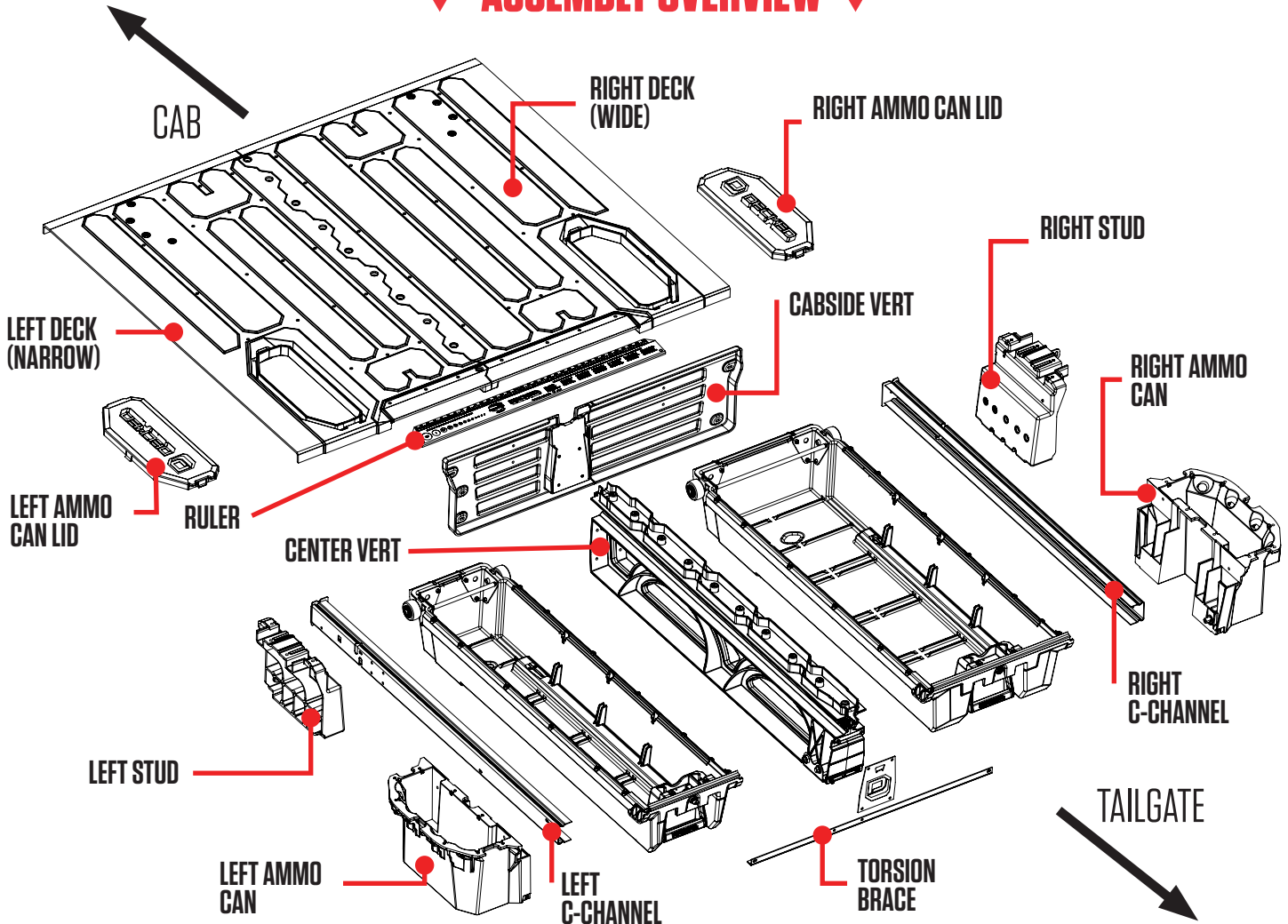

▼ HEY! TORQUE BOY: READ BEFORE YOU INSTALL DECKED ▼

1. **DON'T** go rogue on us, please read the instructions.
2. **DON'T** over tighten bolts, get em' hand-tight.
3. **DON'T** use power tools.
4. If you don't follow directions and do use power tools:
 - 1). Set clutch at a very low setting.
 - 2). If you blow it: Two extra threaded inserts are included in **BAG PREP-EXTRA**. That's all you get, unless you call us and ask for more. The inserts will replace any stripped inserts in the tailgate ammo cans and studs or front face of the center vert at the bottle opener, but **NOT THE TOP OF THE CENTER VERT**, so hand tighten until snug only! You can also screw the inserts back in if dislocated. There is a straight screwdriver slot on the underside of the threaded insert.
5. Start all bolts with fingers to avoid cross-threading.
6. **DON'T** over tighten J-hooks during installation. Just get 'em good and snug; enough to keep the system from moving in the bed.
7. You will have leftover washers – you're welcome.
8. Nice job if you're still reading .

Prevent embarrassing, expletive-filled language, watch our detailed installation video or give us a call. We're happy to help!

208.806.0251 | [DECKED.COM/INSTALLVIDEO](https://www.decked.com/installvideo)

AMMO CAN DRAIN HOLES

(TO DRILL OR NOT TO DRILL.)

• Do you use a tonneau or shell over your DECKED system?

There is no need to drill holes, unless you leave your tonneau open in a deluge.

• Does your DECKED system live outside?

The ammo cans will get water in them. You'll need to drill holes in the ammo cans.

There are two dimples in the bottom of each ammo can. Drill a 1/2" hole at each dimple. A smaller hole will get clogged.

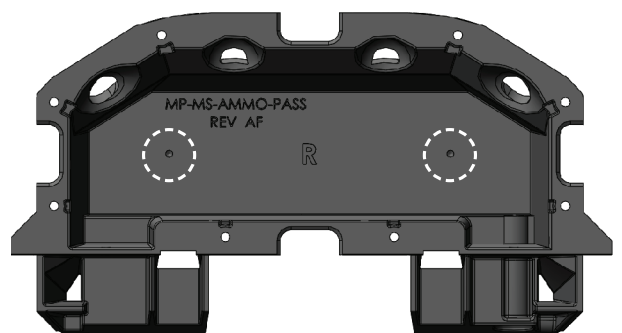
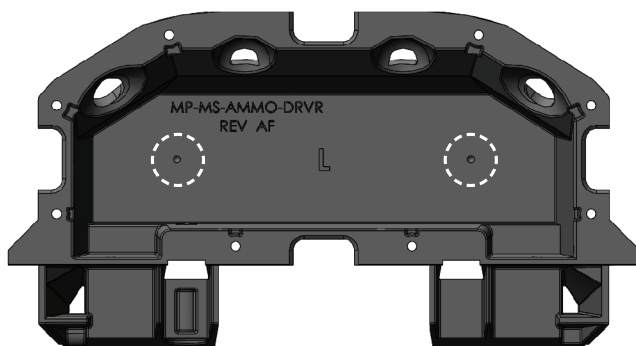

PREP BED: MARK CENTER OF BED

- Use a marking pen or wax pencil to mark a centerline (blue) on the raised center bead.

DETAIL A

MAKE SURE MARK SITS AT LEAST
36cm HIGH (SO YOU CAN SEE IT)

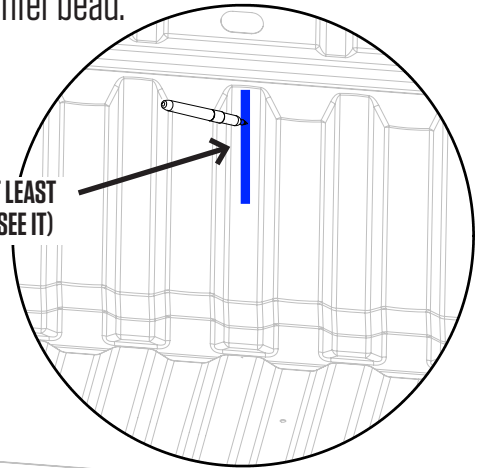

↑ CAB

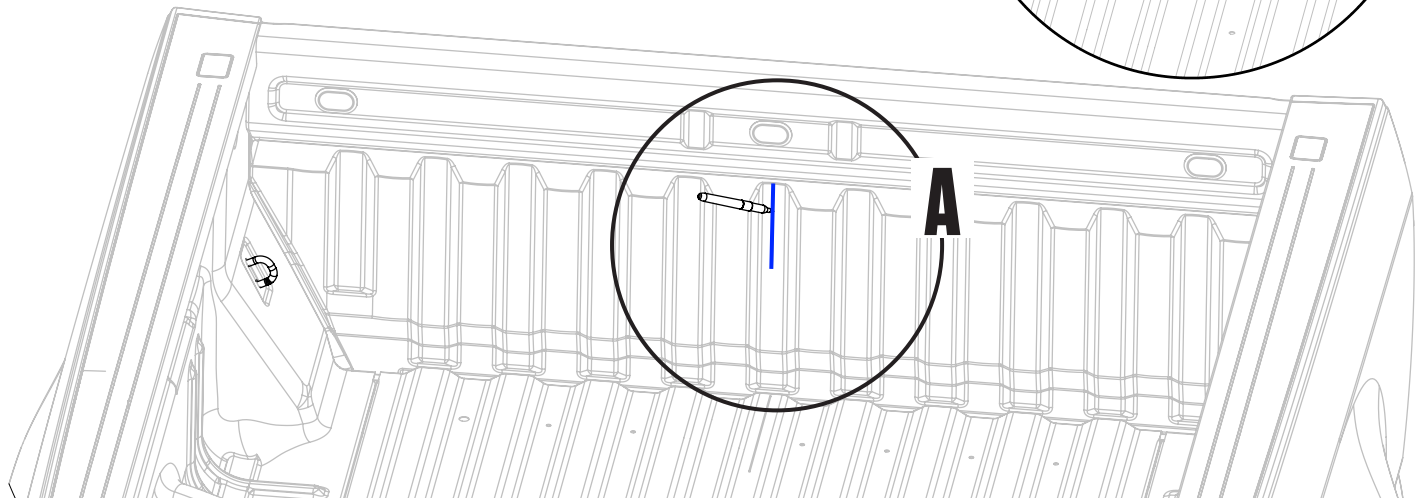

PREP BED: SHIMS

- **2 WIDE SHIMS** and **6 NARROW SHIMS** loose in your hardware kit.
- Using the information below:
 - 1) Clean the bed surface where the shims will be located. Isopropyl alcohol is recommended.
 - 2) Remove tape film and apply shim and apply with pressure.

DETAIL A

Align wide shim to channel in floor as shown 165mm from rear edge of bed (red).
Repeat on the right side of bed.

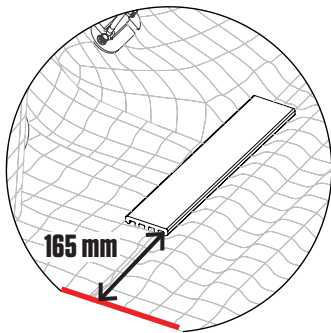

DETAIL C

Align narrow shim to channel in floor as shown 89mm from cabside panel of bed (red).
Repeat on the right side of bed.

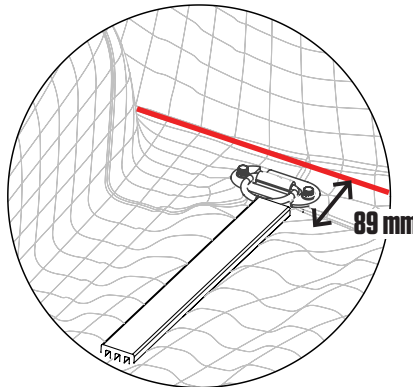

DETAIL D

Align two narrow shim to channels in floor as shown 83mm from cabside panel of bed (red).

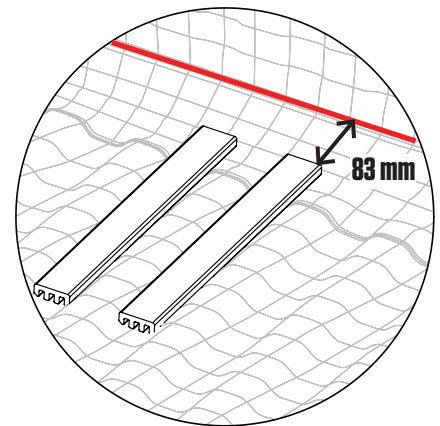

DETAIL B

Align two narrow shims to channels in floor as shown 146mm from rear edge of bed (red).

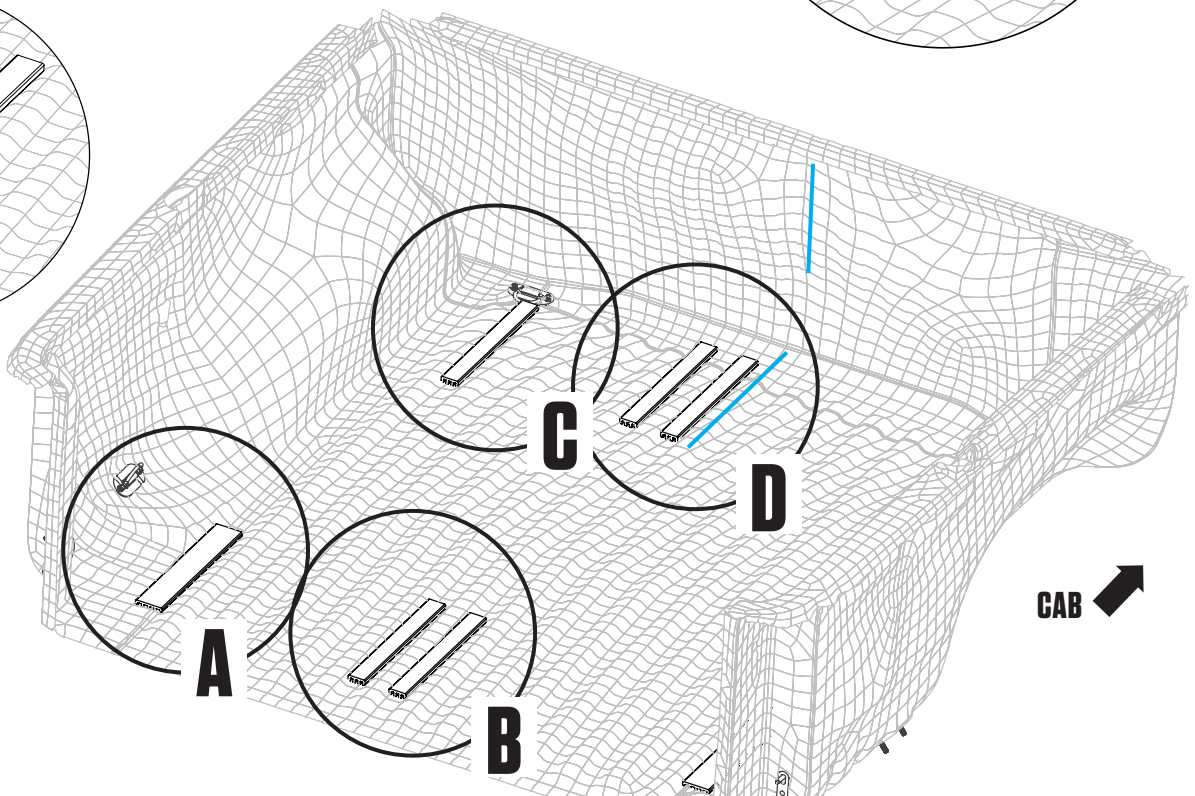
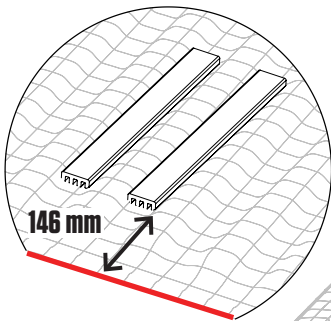

PREP BED: TAILGATE BRACKET

- Install tailgate bracket into existing factory holes with two 1" Torx 40 bolts; BAG PREP MV1/MV3.

NOTE: Bracket must be orientated as shown.

- Tighten securely.
- Repeat other side.

RECOMMENDED TORQUE:

Bolts in labeled bag PREP MV1/MV3 - 19Nm.

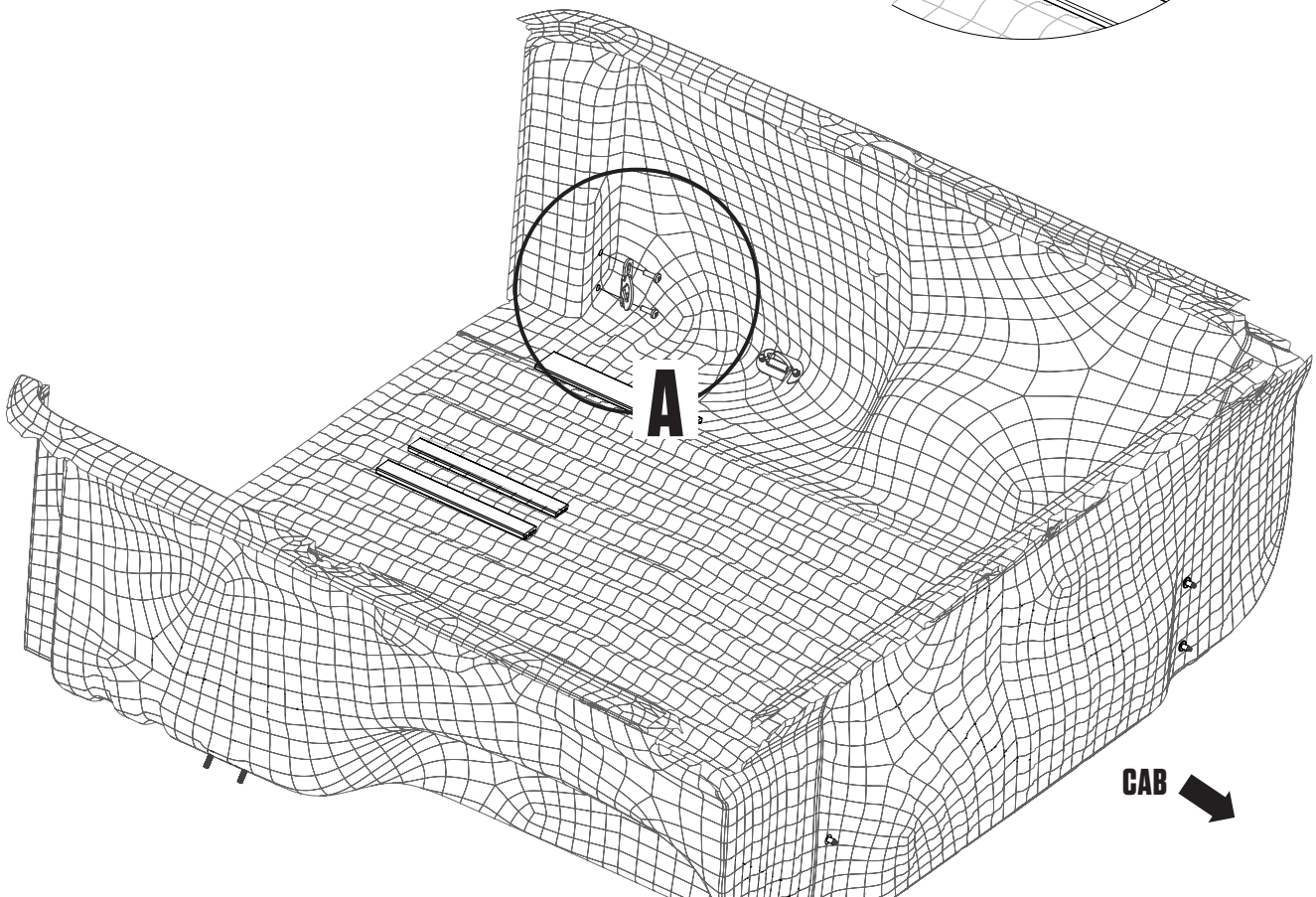
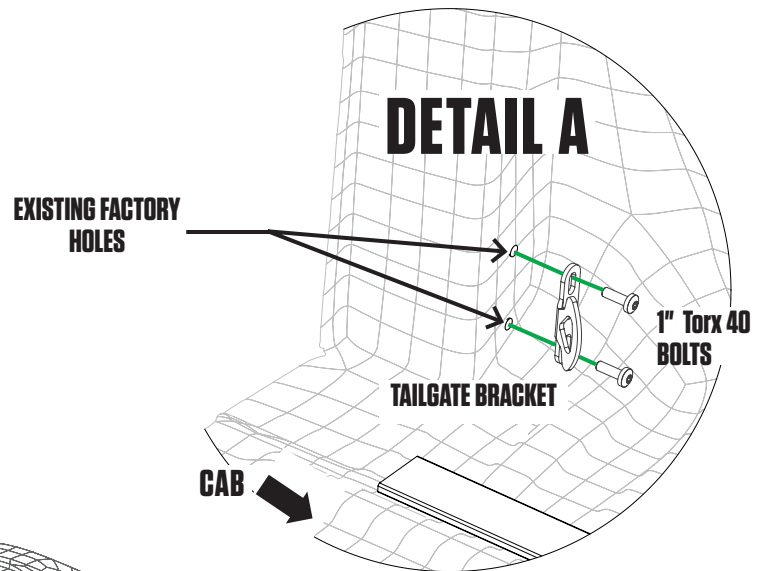

PREP BED: MARK CABSIDE HOLES

- Remove cabside factory tie downs. Save factory bolts. **NOTE: Depending on truck year, you will need a 12 point M10 socket -or- a 12 point M10 bit to remove factory tie downs.**
- **DETAIL A:** Place left mounting bracket in slot cabside of the shim, over the factory holes and loosely install with factory bolts in factory holes. **NOTE: The L-R cabside brackets are NOT the same. The threaded holes must be oriented towards the bed interior. Refer to DETAIL A, DETAIL B.**
- **DETAIL A:** Push cabside bracket against cabside wall and mark two hole locations as shown.
- **DETAIL B:** Repeat steps.
- Remove both left and right cabside brackets and save factory bolts.

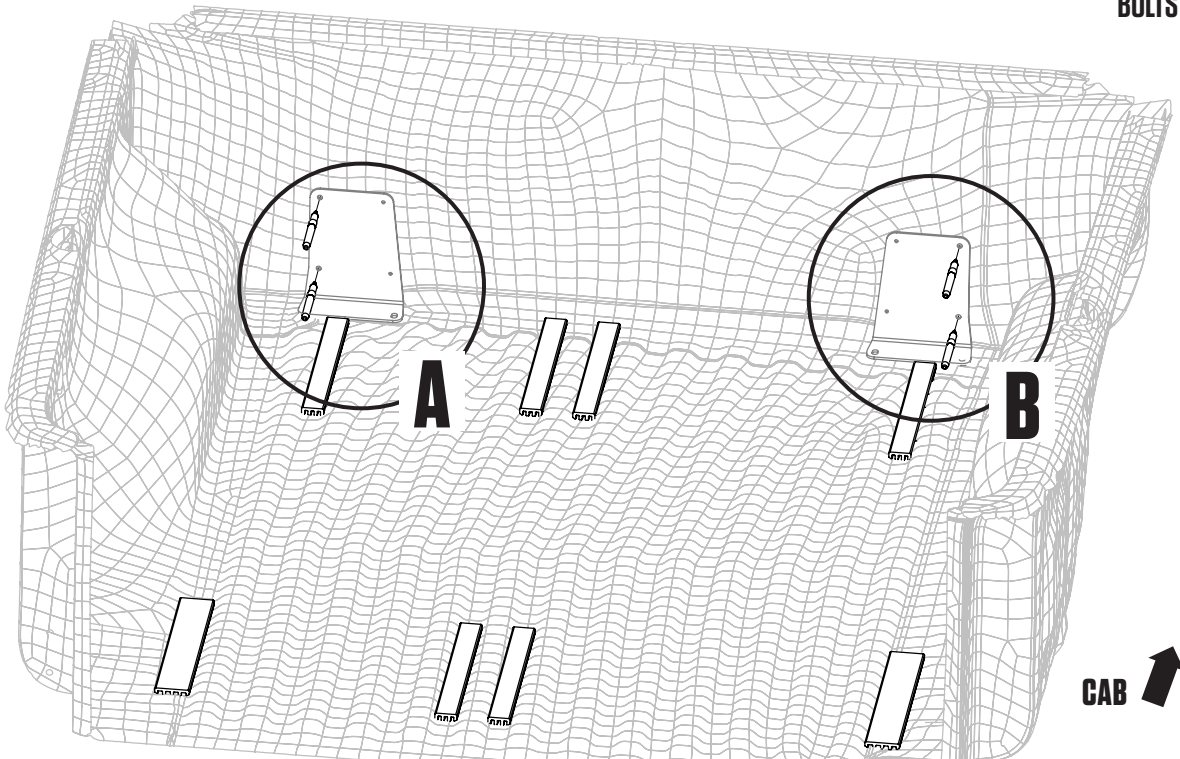
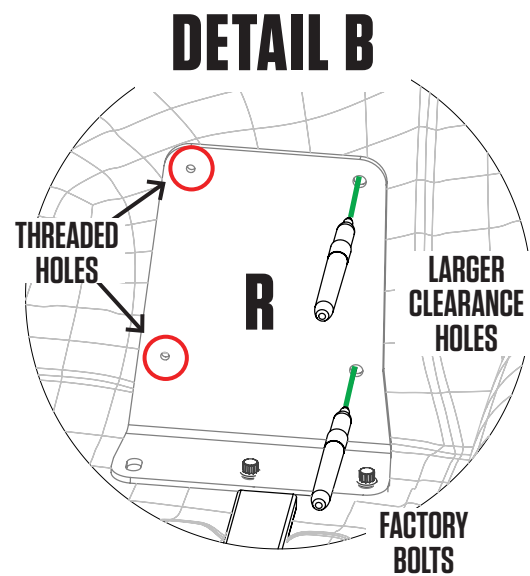
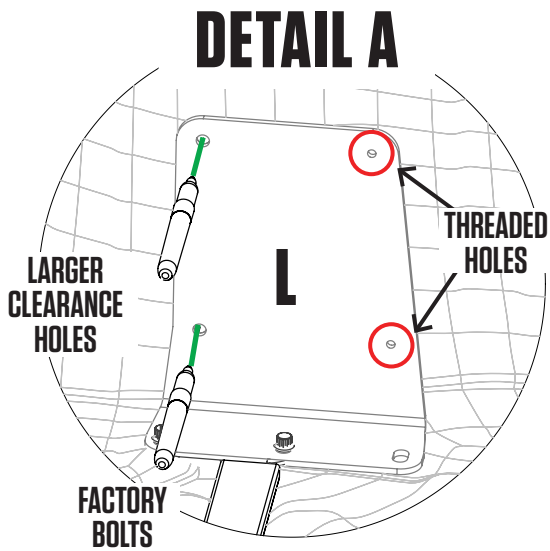

PREP BED: DRILL CABSIDE HOLES

- Drill four 11mm holes at marked locations using a drill stop set to 6mm.

NOTE: To resist corrosion, seal the raw metal edges of the drilled holes with the self-etching primer; BAG PRIMER.

- Install jacknut (yellow) onto jacknut wrench (orange) with 1" placement bolt; BAG PREP MV1/MV3. **NOTE:** Do not use the slightly shorter dogpoint bolts also found in your PREP BAG.
- **DETAIL A:** Insert jacknut into hole. While holding jacknut wrench, tighten bolt with 3/8" socket until jacknut is fully crimped. Remove placement bolt. We've included a 3/8" socket in BAG PREP MV1/MV3.
- Repeat on the remaining three holes.

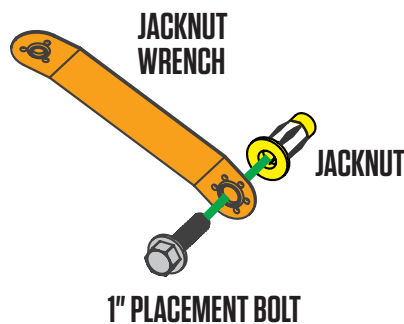

DETAIL A

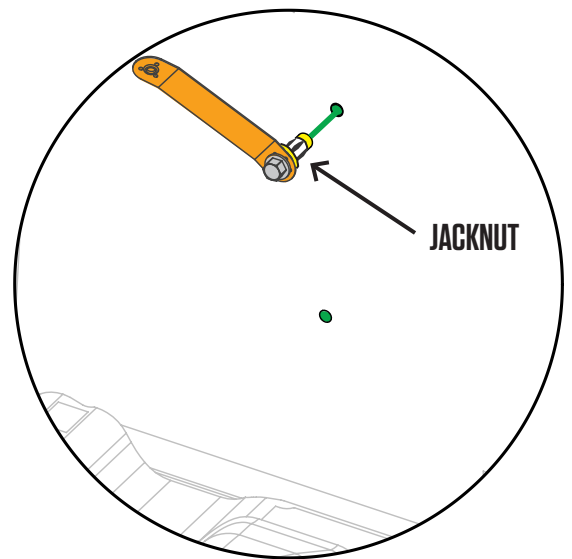

RECOMMENDED TORQUE:
To crimp jacknut - 3Nm.

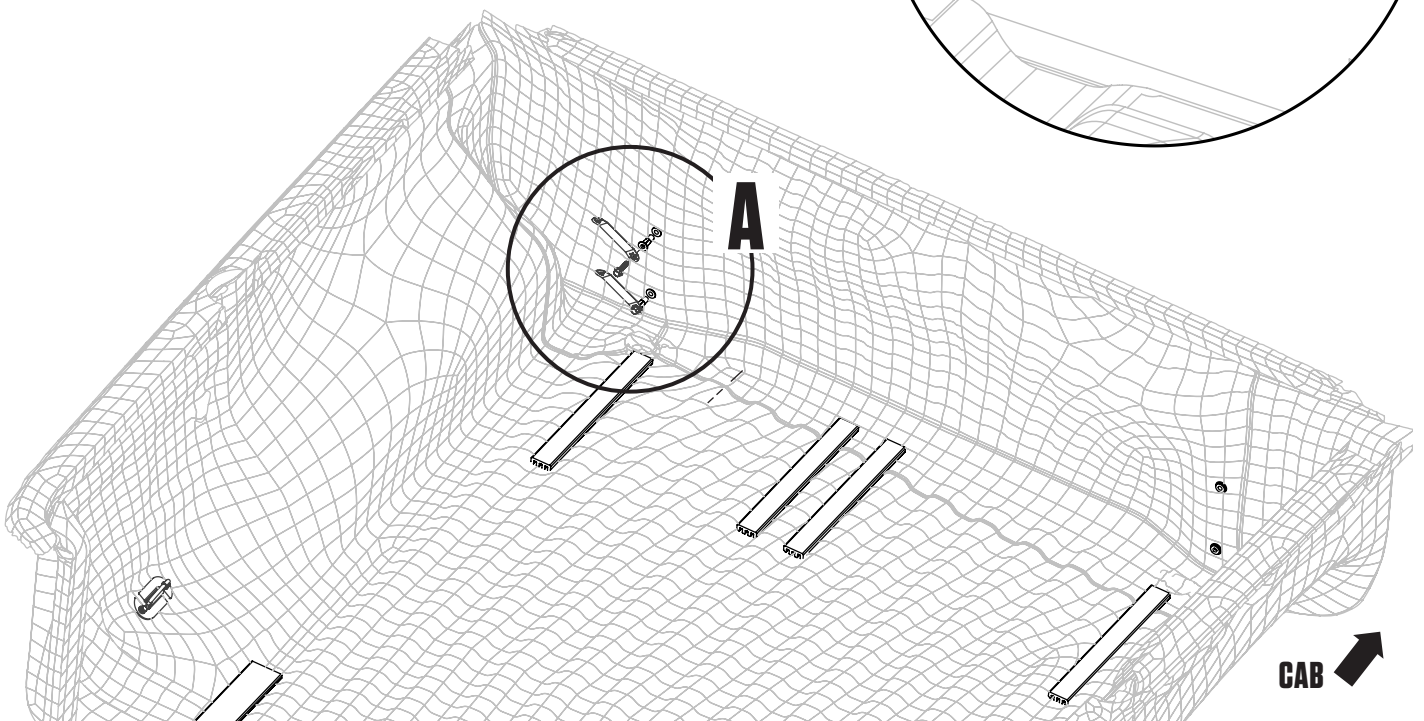

PREP BED: CABSIDE BRACKETS

- **DETAIL A:** Place left mounting bracket in slot cabside of the shim, over the factory holes and loosely install with factory bolts.
- **DETAIL A:** Push mounting brackets up against cabside wall of bed and install two 9/10" bolts with nylon washers into plusnuts; **BAG PREP MV1/MV3, BAG WASHERS.**

NOTE: These are the same bolts as the dogpoint bolts in your S1 BAG.

- Tighten all bolts.
- **DETAIL B:** Repeat steps in DETAIL A.



DETAIL A

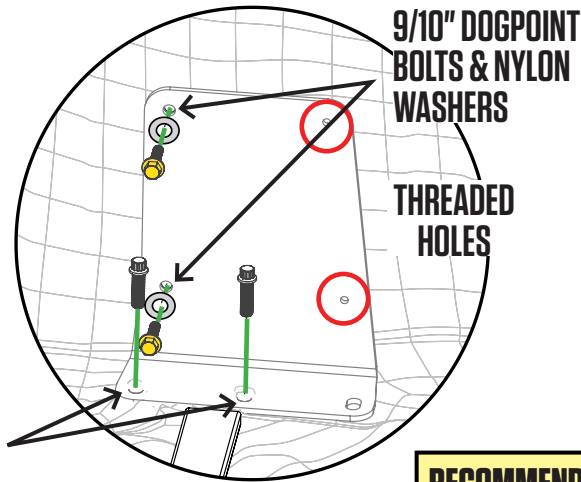

9/10" DOGPOINT BOLTS & NYLON WASHERS

DETAIL B

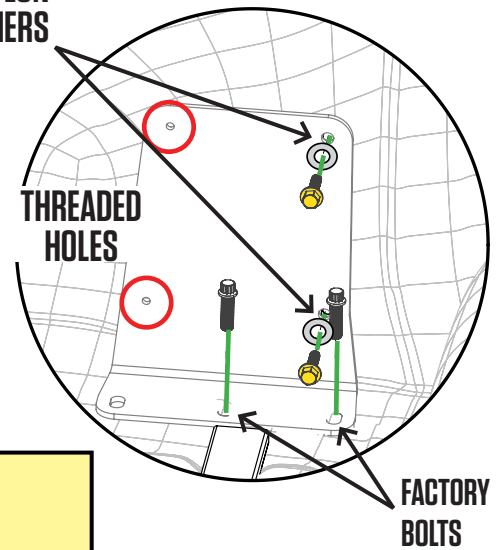

RECOMMENDED TORQUE:
Factory bolts - 19Nm.
23mm dogpoint screws - 3Nm.

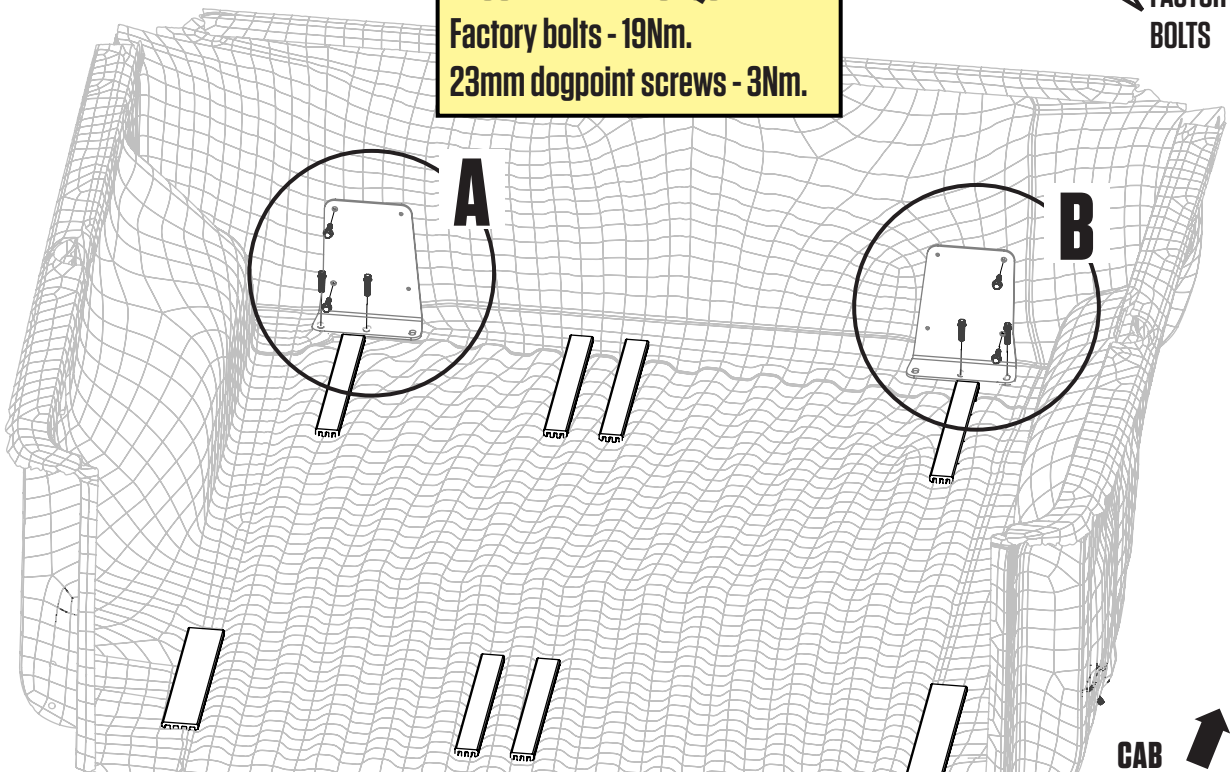

CAB ↑

ASSEMBLY: CENTER VERT + CABSIDE VERT

NOTE: Perform the next few steps on a flat surface like a garage floor.

- Attach center vert to cabside vert with four bolts. Alternate to tighten; BAG S1.

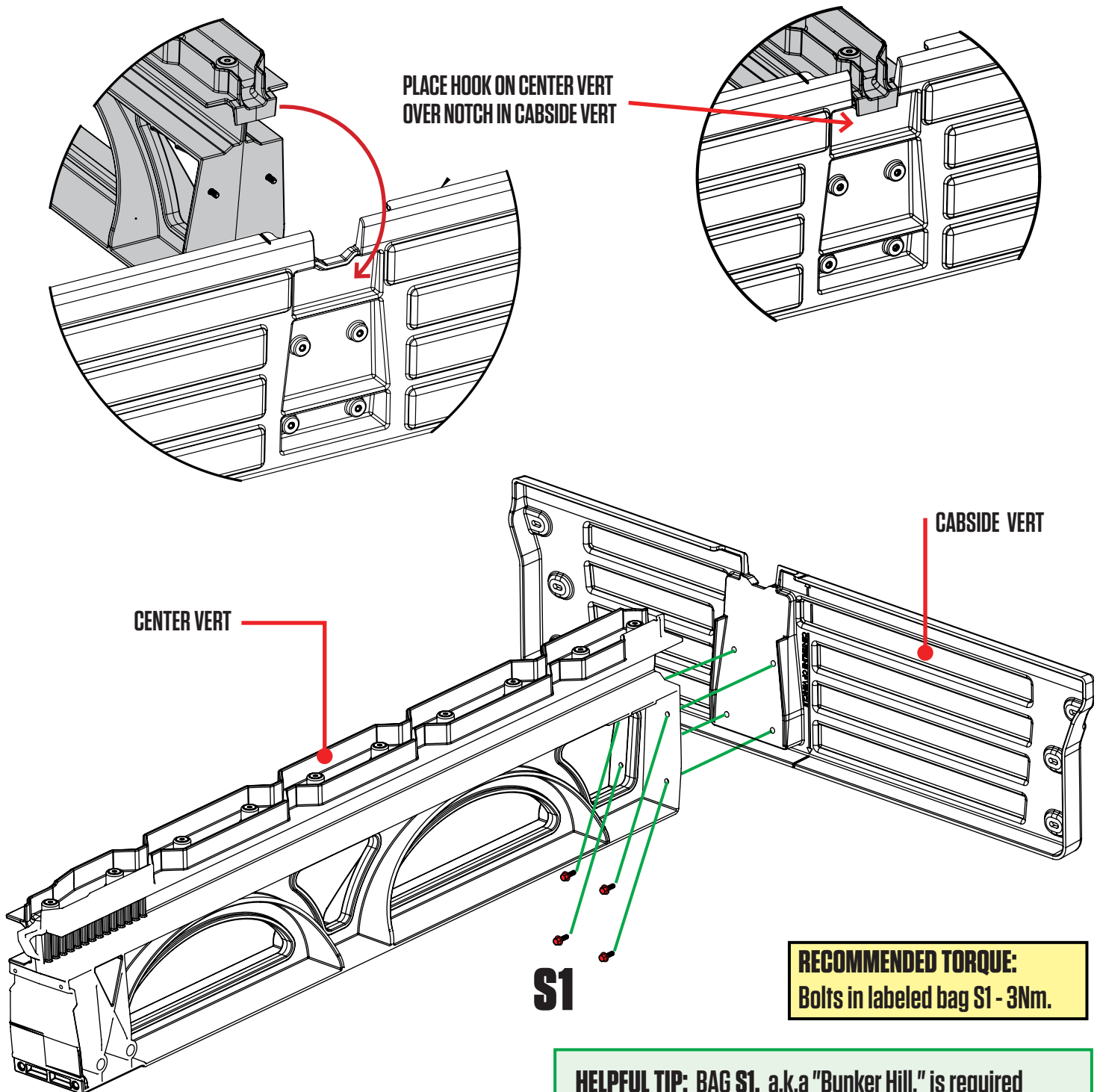

ASSEMBLY: LOOSELY ATTACH STUDS (YUP)

- **LOOSELY** attach studs to cabside vert with six bolts; BAG S1.

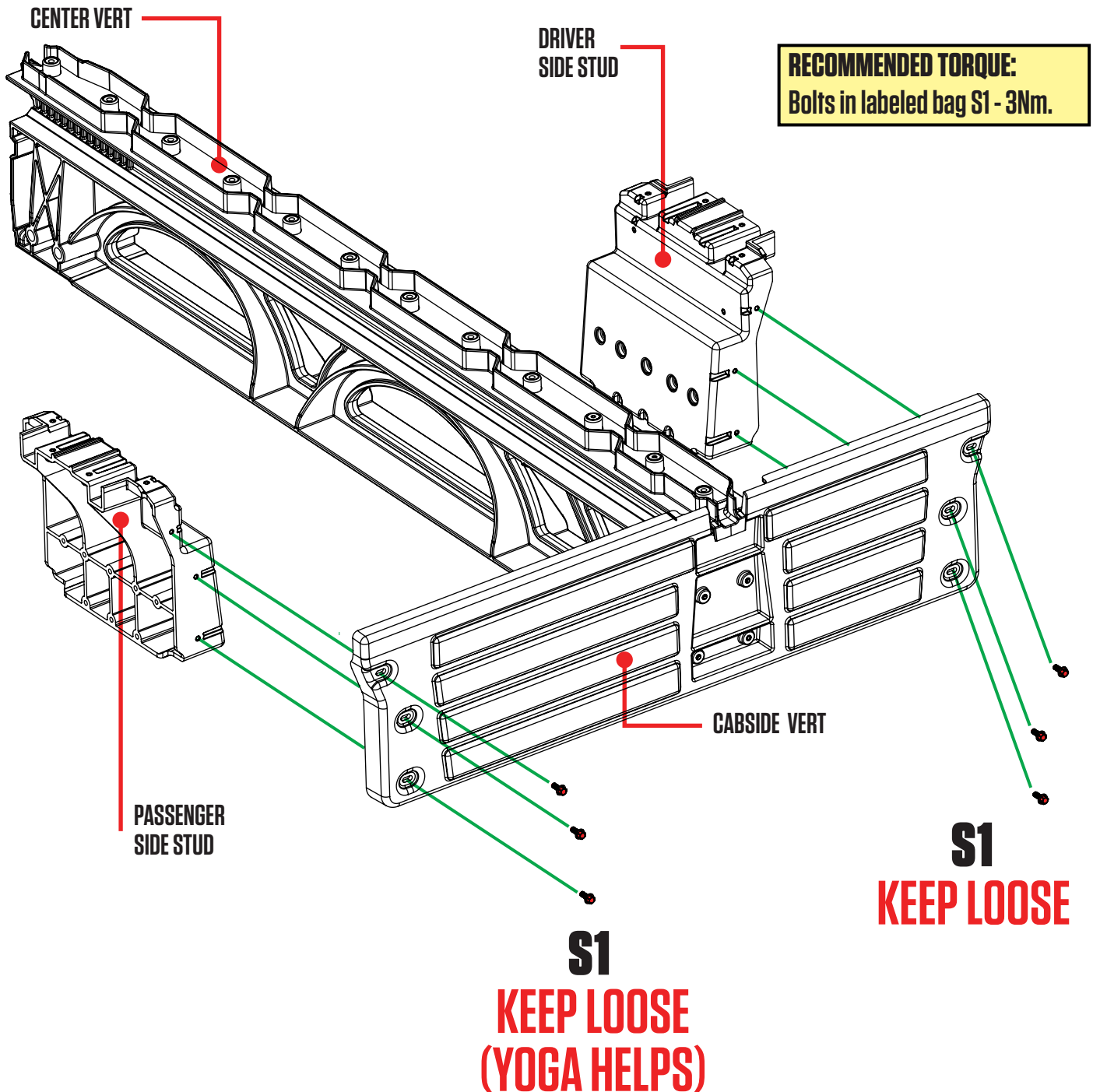

ASSEMBLY: ALIGN & TIGHTEN STUDS (YUP)

NOTE: This step ensures the studs are properly located before tightening bolts. It's important.

- Place ammo cans to support tailgate end of deck panels.
- Lift deck panels on center vert + stud + cabside vert assembly.
- Slide studs around L-R until deck panels are seated.
- **DETAIL A:** Loosely secure four bolts to hold decks onto studs; **BAG S1**.
- Now you can securely tighten the bolts that hold the studs to the cabside vert.
- Unbolt deck from studs, remove deck panels, save bolts, remove ammo cans and set aside for later assembly.

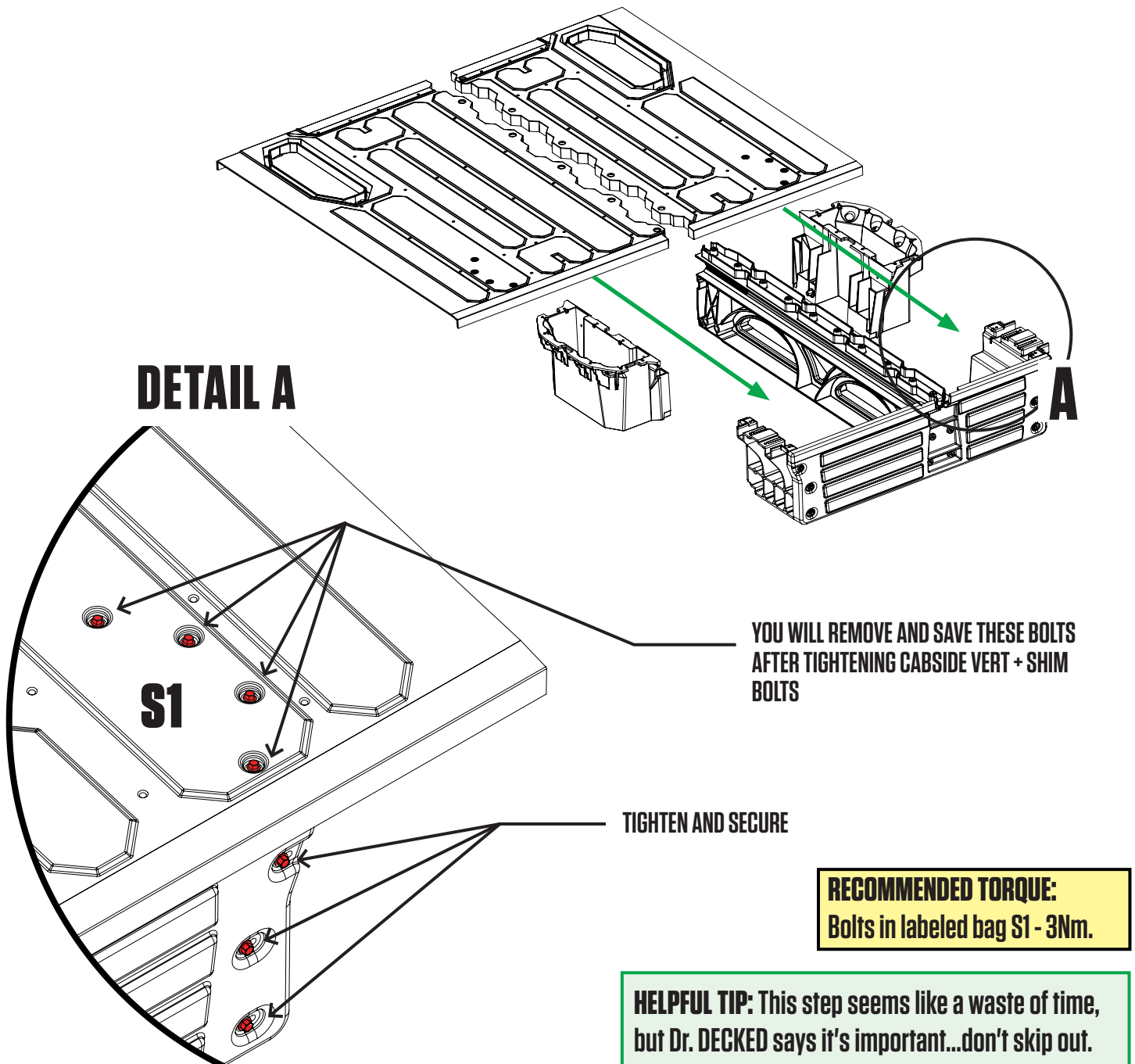

INSTALL: MOUNT ASSEMBLY

IMPORTANT: Prior to placing installation in vehicle, enlarge the four factory holes in the cabside vert with a 13mm drill bit. DO NOT ENLARGE HOLES IN CABSIDE BED WALL.

- Place cabside vert + center vert + stud assembly in truck bed.
- **DETAIL A:** Secure assembly using two 9/10" bolts and two washers; BAG PREP MV1/MV3. Make sure to start with the lower bolt to ensure proper alignment. **NOTE:** These are the same bolts as the dogpoint bolts in your S1 BAG.
- Repeat other side.

DETAIL A

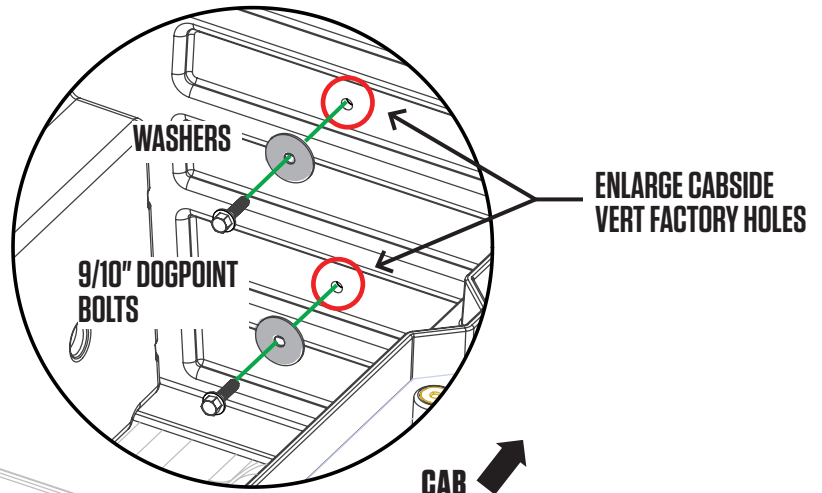

HELPFUL TIP:

Enlargement of cabside vert holes must be done **BEFORE** assembly is placed into the truck bed. **DO NOT** enlarge the holes you drilled into truck bed wall.

RECOMMENDED TORQUE:

Bolts from BAG PREP MV1/MV3 - 3Nm.

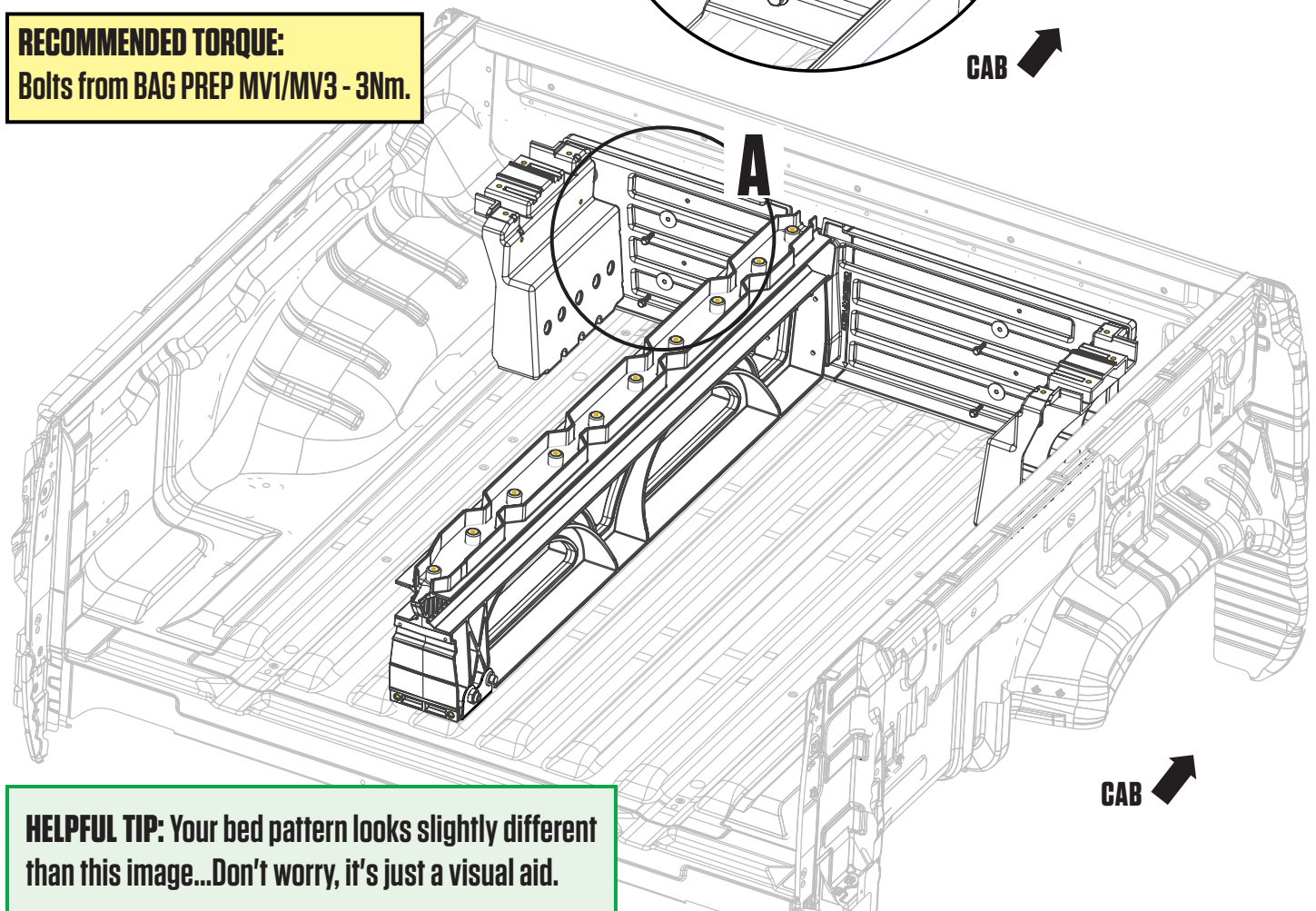

HELPFUL TIP: Your bed pattern looks slightly different than this image...Don't worry, it's just a visual aid.

INSTALL: C-CHANNELS

IMPORTANT: There is a left and right ammo can. The inside of each ammo can is marked L or R.

- Loosely place left side ammo can at tailgate corner of bed. The axle will be closest to you.
- Place C-channel on ledge of stud and ammo can with end plate on the stud (cabside).
- **DETAIL A:** Place nylon washer on eight .905" bolts. Insert two bolts through C-channel into ammo can and loosely fasten with flanged nuts. Make sure the bolt head is on the C-channel side, not inside the ammo can; **BAG S1, BAG WASHERS, BAG N1. KEEP LOOSE.**
- **DETAIL B:** Attach C-channel to stud with same bolts; **BAG S1.**
- Repeat right side.

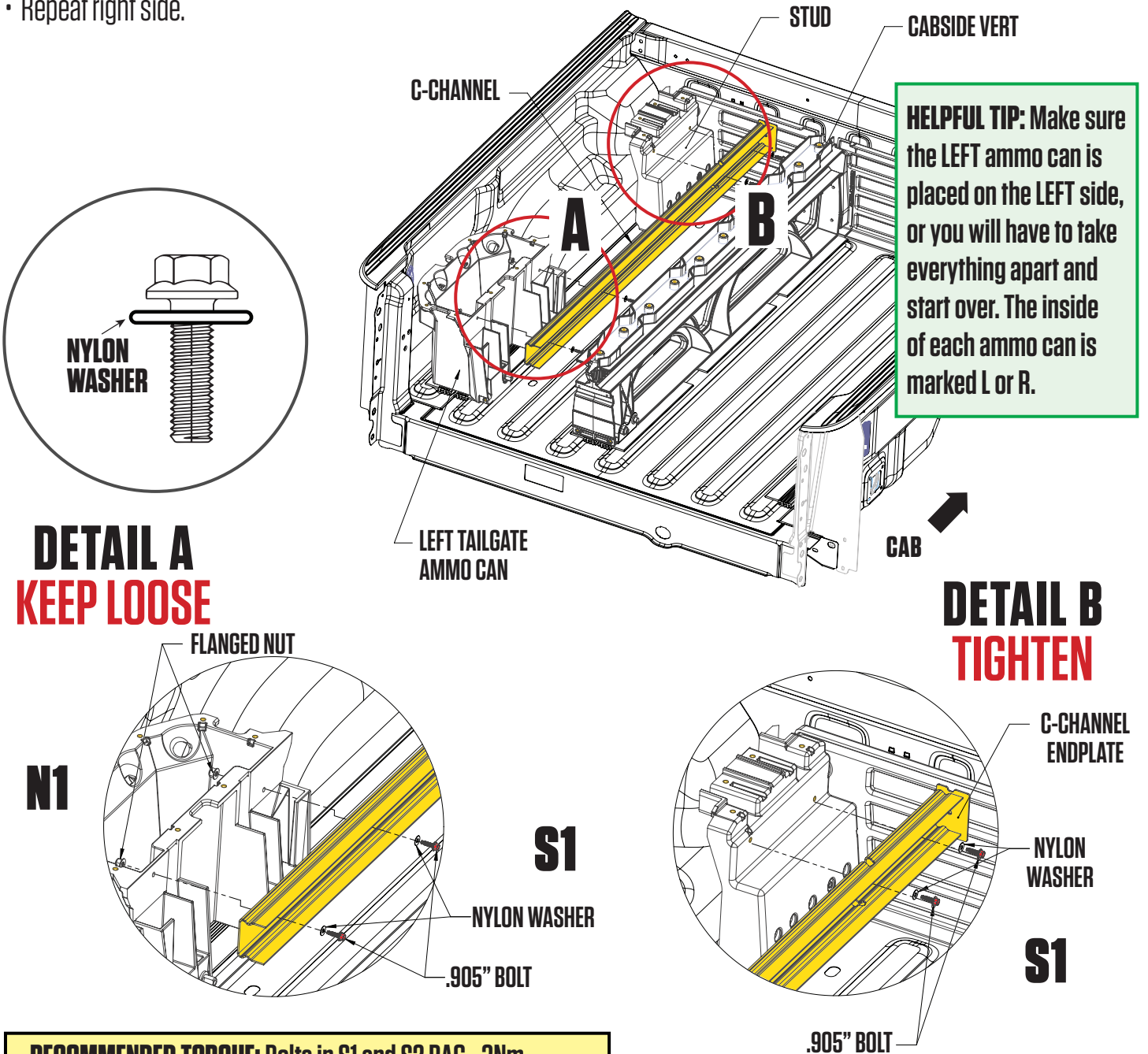

HELPFUL TIP: Make sure the LEFT ammo can is placed on the LEFT side, or you will have to take everything apart and start over. The inside of each ammo can is marked L or R.

DETAIL A
KEEP LOOSE

DETAIL B
TIGHTEN

RECOMMENDED TORQUE: Bolts in S1 and S2 BAG - 3Nm.

INSTALL: DECK HALVES

- Loosely place deck panel on side stud, center vert and ammo can.
- Shift ammo can forward, rearward, L-R, as necessary to align with fully seated deck panel.
- Loosely assemble:
 - Five or six bolts (depends on bed length - NO WASHERS) through deck panel into center vert; **BAG S1**.
 - Four bolts with nylon and rubber washers installed as shown through deck panel into stud; **BAG S1, BAG WASHERS**.
 - Eight bolts with nylon and rubber washers installed as shown through deck panel into ammo can; **BAG S1, BAG WASHERS**.
 - Tighten all **S1** bolts.
 - **Securely tighten C-channel/ammo can nuts and bolts.**
- Repeat other side (making sure you don't forget to securely tighten C-channel/ammo can nuts and bolts).
- We have included extra washers - don't worry if you have leftovers.

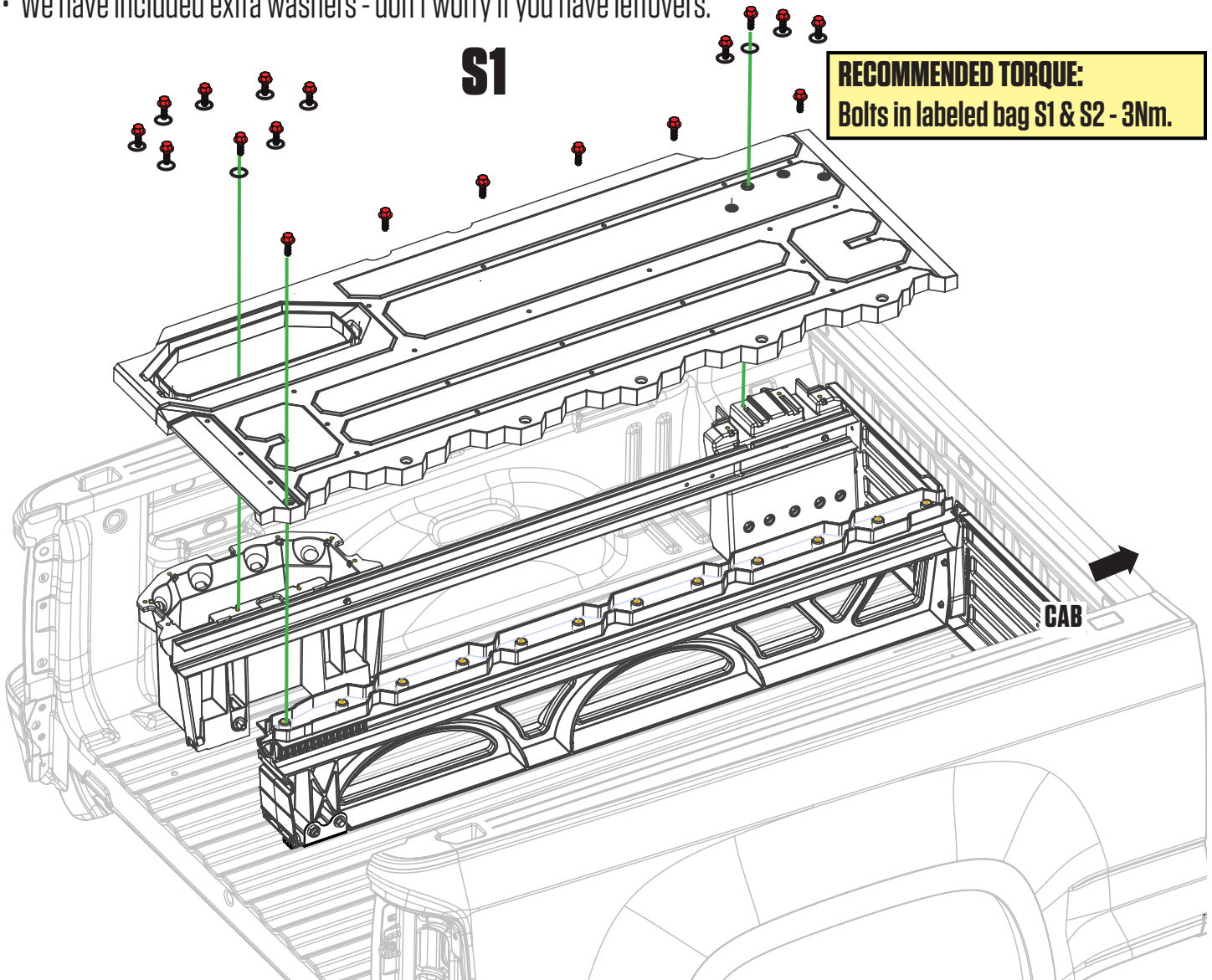
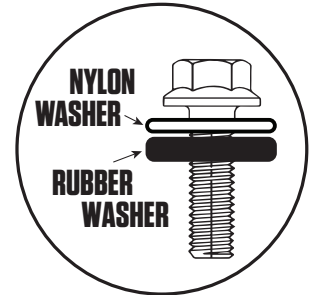

DRAWERS: BRACKETS + WHEELS

- Each drawer has a left and a right bracket. Bolt brackets into place via bottom two holes in bracket with 3/4" length bolts. Use the 2" length bolt for the upper cabside wall hole in bracket; **BAG DRAWER 1**.
- Install a tube brace in each drawer with two 3/4" length bolts; **BAG DRAWER 1, BAG DRAWER 2**.
- Attach wheels onto drawer brackets with a 7/32" hex wrench; **BAG WHEELS**.

NOTE: We've provided a hex wrench in your **BAG PREP MV1/MV3**.

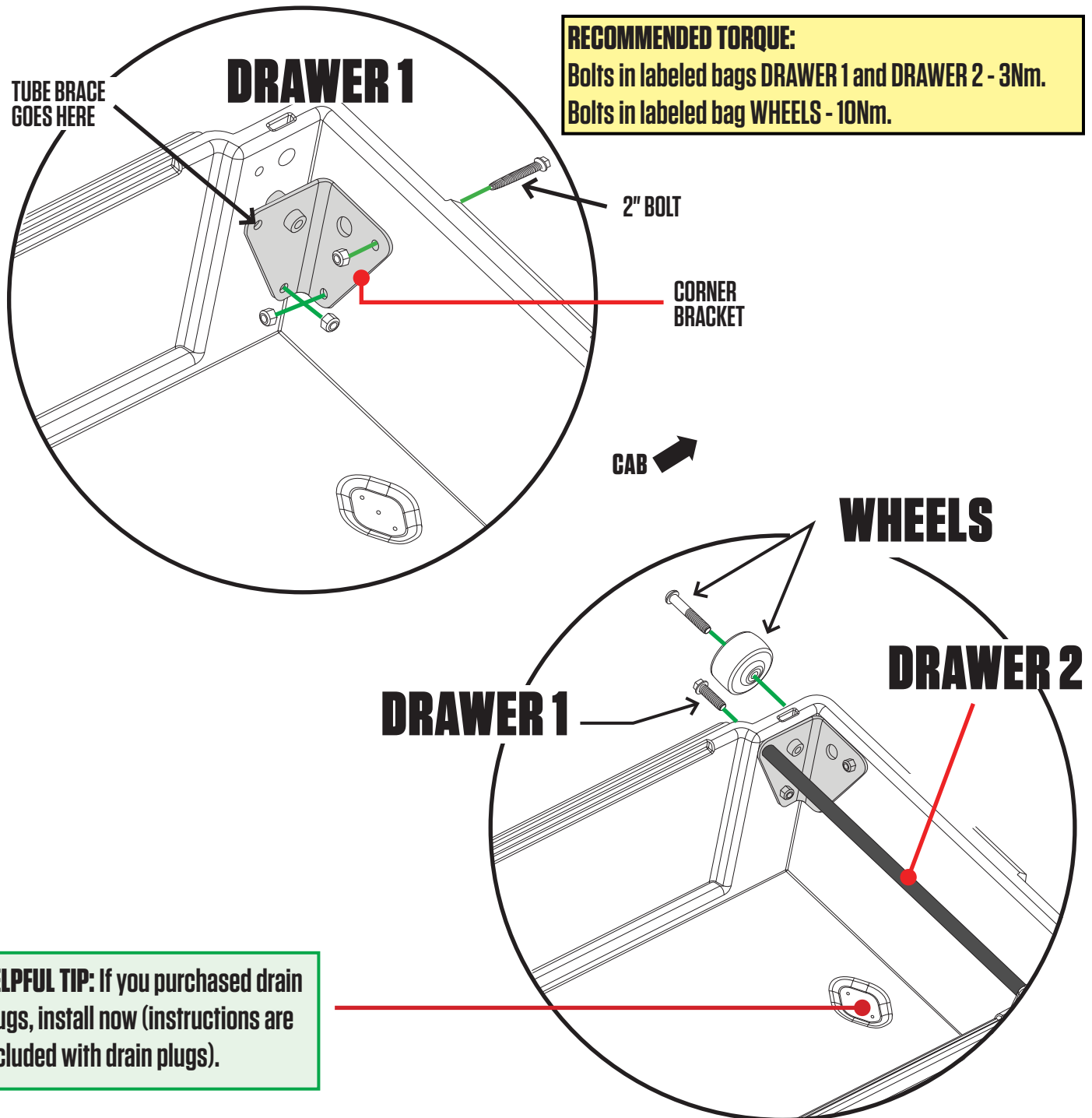

DRAWERS: AXLE WHEELS + WEATHERSTRIPS

- Slide narrow drawer into driver side drawer cavity. **NOTE: It is easier to fully install narrow drawer first.**
- **DETAIL A:** Install two tailgate wheels onto narrow drawer axles with a 7/32" hex wrench; **BAG WHEELS.**
- Repeat with wide drawer.
- **DETAIL B:** Install weatherstrips on top of drawer edges **WITH WIPER BLADE POINTING TOWARD DRIVER.**
IMPORTANT: Facing the weatherstrip the wrong way will funnel water into drawer: DUH!

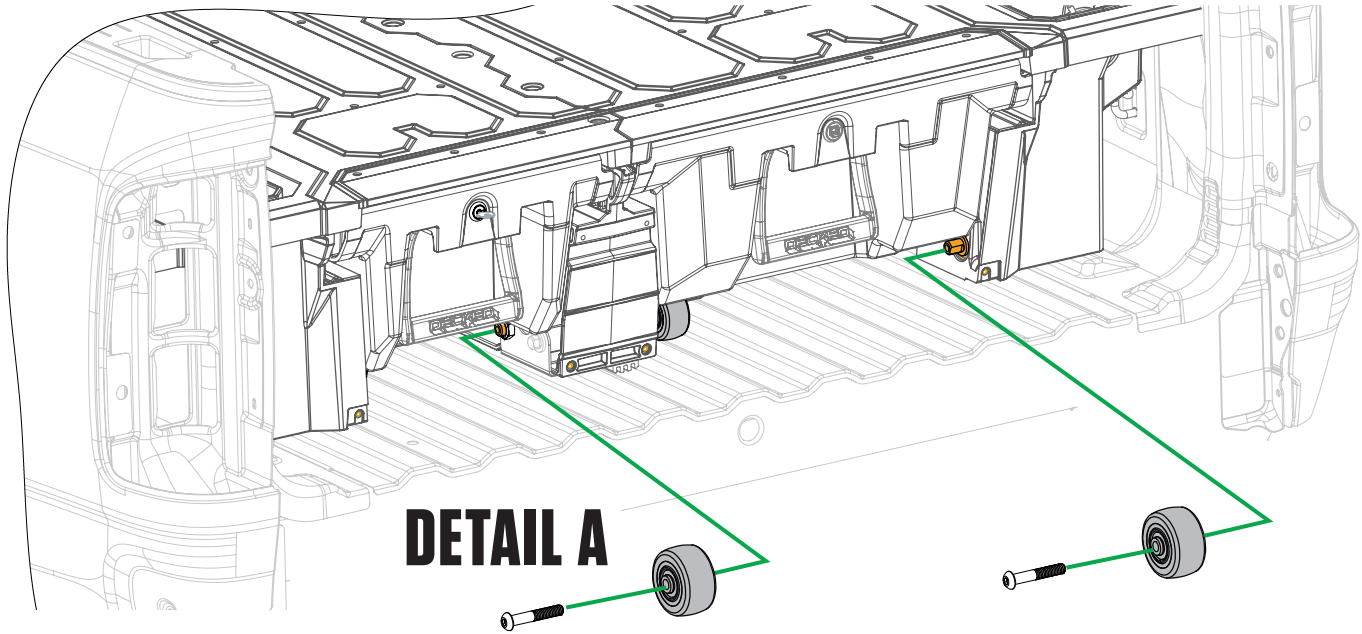

RECOMMENDED TORQUE:
Wheel bolts - 10Nm.

HELPFUL TIP: To make this step easier, jam a 2" piece of material under drawer, or get your pal to pinch the drawer up to the deck to give you better leverage.

HELPFUL TIP: Cut weatherstrips if they overhang.

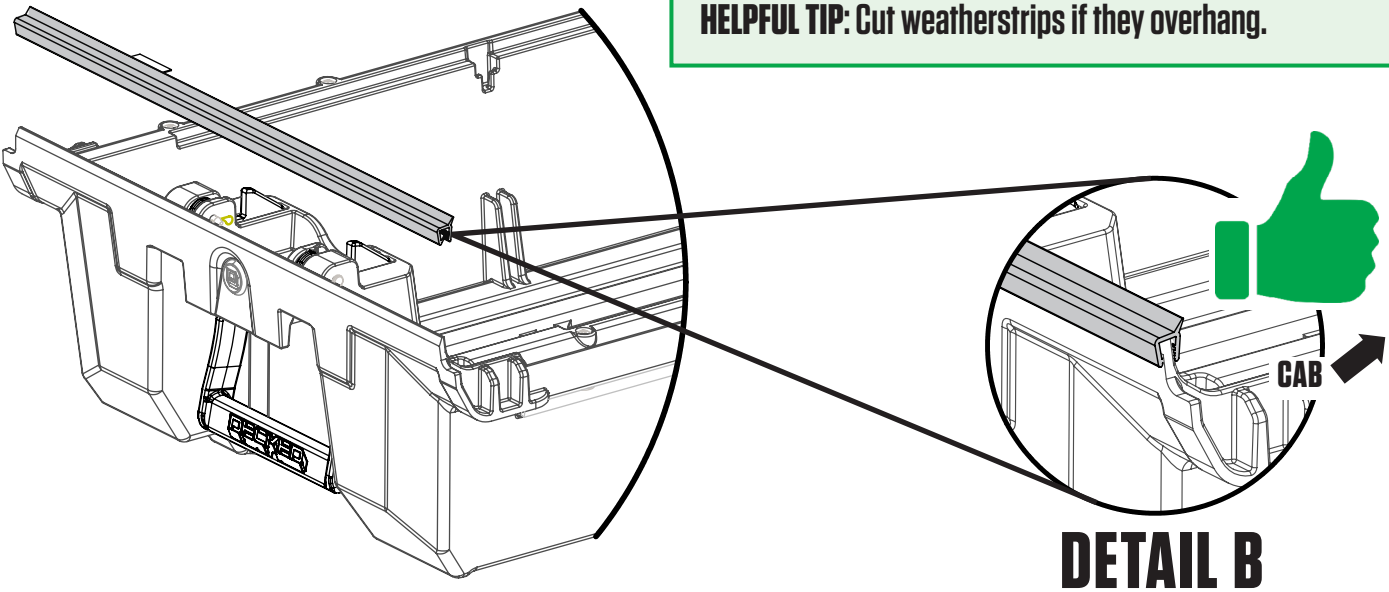

THE FUN STUFF: TORSION BRACE + BOTTLE OPENER

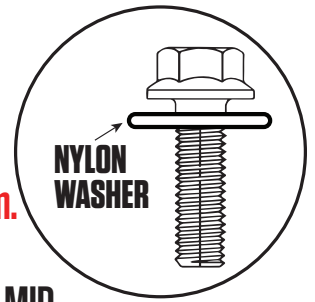

- Slide torsion brace under center vert and tailgate ammo cans.
NOTE: If you jumped the gun and tightened the J-hooks when installing, loosen them.
- Loosely install:
 - Two 1/2" length bolts through upper holes in bottle opener into center vert; **BAG FINAL MID.**
 - Two bolts with nylon washers through the end holes in torsion brace into ammo cans; **BAG S1.**
 - Two bolts with nylon washers through the bottom bottle opener holes and torsion brace into center vert; **BAG S1.**
- Align bottle opener to edges of center vert and tighten four bottle opener bolts.
- Tighten end bolts into tailgate ammo cans.
- **Finally...Tighten the J-hooks! DO NOT OVER TIGHTEN, just make snug. Make sure the gap between the sidewall of the bed and the deck is equal on both sides.**
- Install bolt thread protectors on J-hook ends if provided.

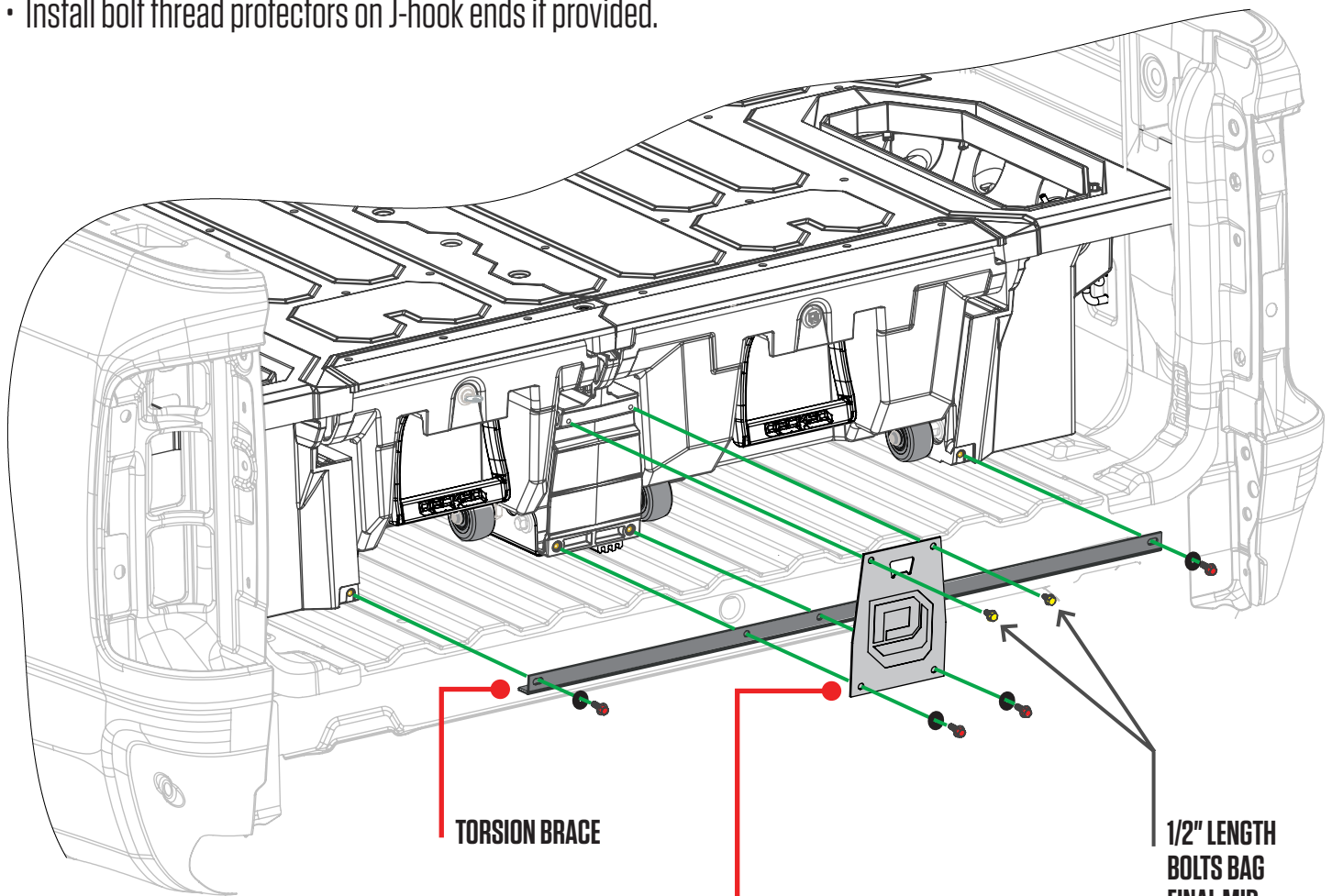

HELPFUL TIP: Bottle opener goes outside of torsion brace.

RECOMMENDED TORQUE:
Bolts in labeled bag S1 - 3Nm.
J-hooks - 1Nm.

INSTALL: J-HOOKS

- Install J-hook onto tie down bracket and through hole closest to the **tailgate** in ammo can; **BAG J8**.
- Install winged-spherical nut-washer, round side down, onto J-hook and partially tighten using your fingers only.
- IMPORTANT: Keep J-hook assembly loose.**
- Repeat other side.
- Tighten the J-hooks, but **DO NOT OVERTIGHTEN!** Make sure the gap between the side wall of the bed and the deck is equal on both sides.
- Install bolt thread protectors on J-hook ends; **BAG FINAL MID.**

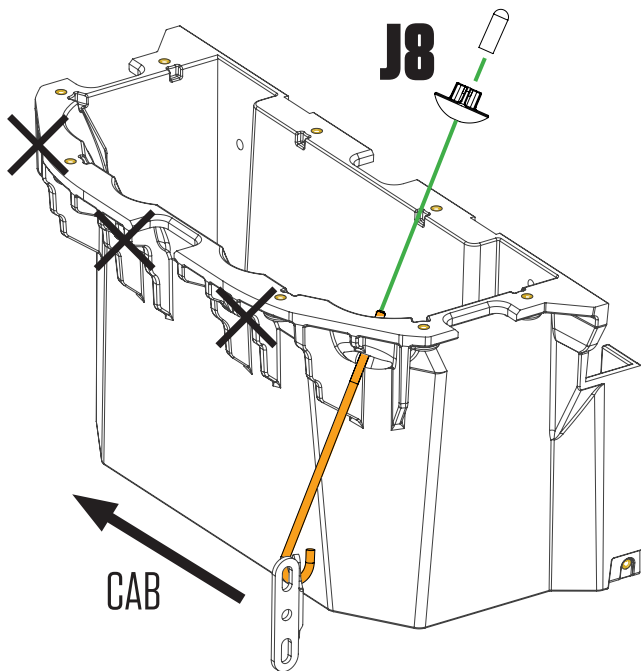

LEFT AMMO CAN
KEEP LOOSE

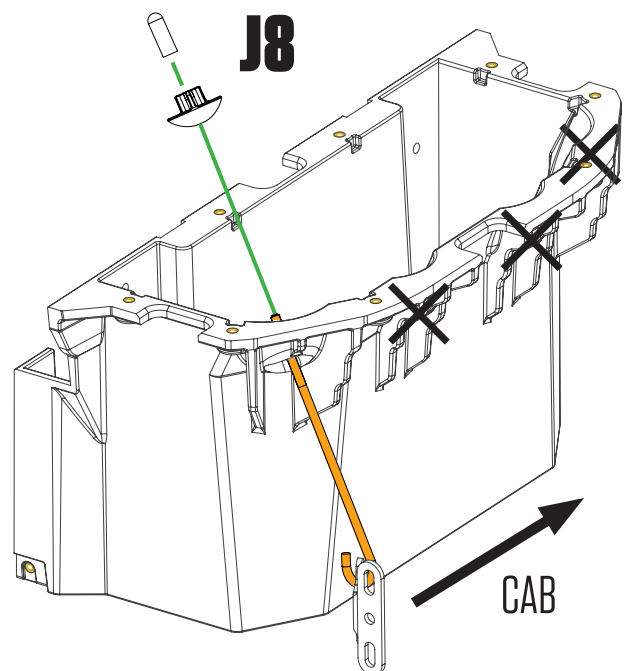

RIGHT AMMO CAN
KEEP LOOSE

HELPFUL TIP: Make sure the hooks open toward tailgate.

IMPORTANT: You're almost there, so get your favorite beverage ready to crack open in the bottle opener and make a toast to your truck. When finished, immediately post a photo of your significant other, child or canine (in no order of significance - please someone show us your pet alligator) appreciating your accomplishment. Add hashtag #DECKEDUSA | @DECKEDUSA.

FINAL STEPS: THE RULER

- Install ruler with six 1/8" hex screws; **BAG FINAL MID**. Start screws with fingers to avoid cross-threading. Tighten just until snug. Overtightening will strip the inserts.

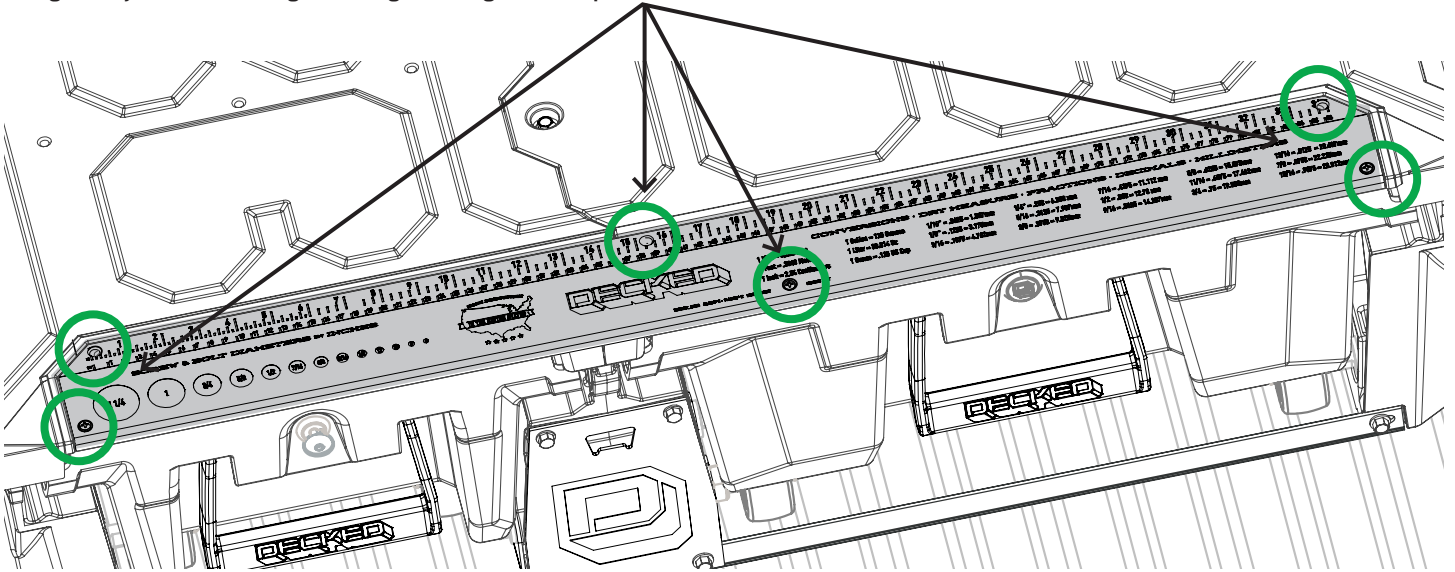

FINAL STEPS: AMMO CAN LIDS

- **DETAIL A:** Ammo can lids are left (marked L) and right (marked R) side specific.
- **DETAIL B:** Holding lid in orientation shown, insert tab on tailgate end of ammo can lid and push the cabside end of lid down to secure. Don't be afraid to push down hard.
- Insert lock hole plugs, unless you are fitting the optional drawer locks, in which case install drawer locks now (instructions with locks); **BAG FINAL MID**.

DETAIL A

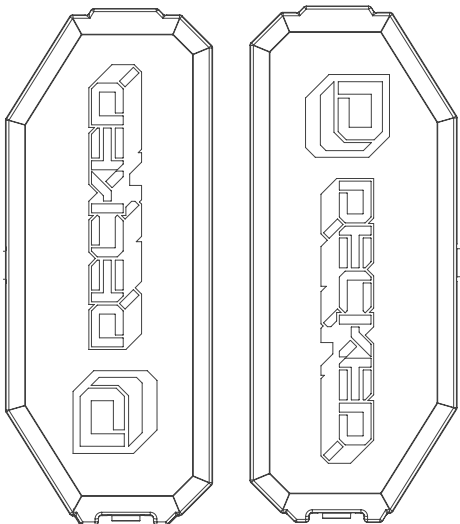

LEFT AMMO
CAN LID

RIGHT AMMO
CAN LID

DETAIL B

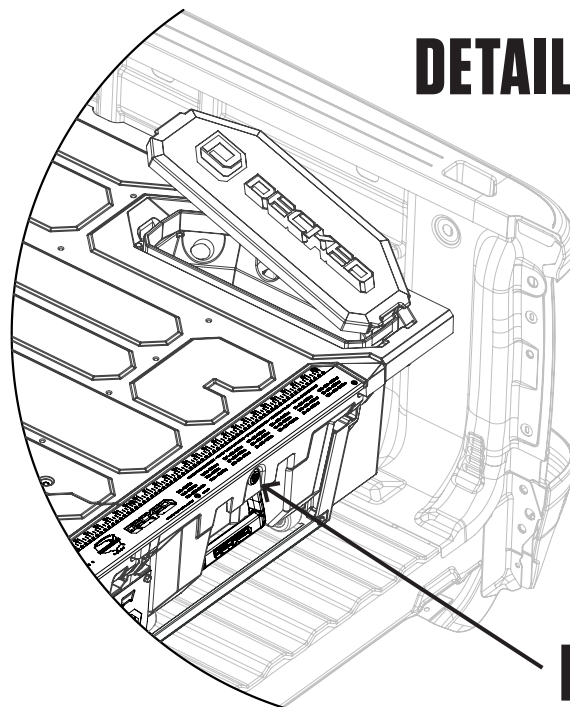

FINAL MID

DECKED Products – Limited Lifetime Warranty

(Valid on DECKED Products purchased on or after 8/1/2021)

DECKED LLC, (the “Manufacturer”) warrants the original purchaser only that DECKED Truck and Van Products (The “DECKED” Product) will be free from defects in material and workmanship from the date of purchase and continuing for the expected lifetime of the DECKED Product. The DECKED Product must be registered by the original purchaser with DECKED, LLC via its website at, www.decked.com/register, and a copy of the original sales receipt must be supplied to the Manufacturer at the time a warranty claim is made. This warranty terminates if the original purchaser transfers the DECKED Product to any other person or vehicle.

WHAT IS COVERED

All DECKED Products identified above on or after August 1, 2021

DECKED's Limited Lifetime Warranty applies to US and Canadian customers only. International shipments are covered by DECKED's 3 Year Limited Warranty.

WHAT WE WILL DO TO CORRECT PROBLEMS

Subject to the limitations and exclusions described in this limited warranty, the Manufacturer will remedy defects in workmanship or materials by providing one of the following remedies at its option and without charge to the original purchaser for parts: (a) repairing the defective portion of the DECKED Product or (b) replacing the entire DECKED Product. In addition, the Manufacturer may elect at its option not to repair or replace the DECKED Product, but rather issue to the original purchaser a refund equal to the purchase price paid for the DECKED Product or a credit to be used towards the purchase of a new DECKED Product.

WHAT IS NOT COVERED

This limited warranty expressly excludes:

- Damage or defects caused by normal wear and tear, cosmetic rust, scratches, accidents, unlawful vehicle operation, installation in a non-supported vehicle or installed in a vehicle which does not match the DECKED Product's SKU-intended fitment or use, or modification of the product, or any types of repair of a DECKED Product other than those authorized or provided by the Manufacturer.
- Damage or defects resulting from conditions beyond the Manufacturer's control and specifications including, but not limited to modification, misuse, overloading, or failure to assemble, install or use the DECKED Product in accordance with the Manufacturer's written instructions or guidelines included with the DECKED Product or separately made available to the original purchaser.
- Damage to the contents of the DECKED Product or vehicle.
- TO THE EXTENT PERMITTED BY LAW, IN NO EVENT SHALL THE MANUFACTURER BE LIABLE FOR ANY INCIDENTAL, SPECIAL, INDIRECT, OR CONSEQUENTIAL DAMAGES, INCLUDING ECONOMIC LOSS, WHETHER RESULTING FROM NONPERFORMANCE, USE, MISUSE, OR INABILITY TO USE THE DECKED PRODUCT OR THE MANUFACTURER'S NEGLIGENCE.

NO OTHER EXPRESS WARRANTY APPLIES

This Limited Lifetime Warranty is the sole and exclusive warranty for DECKED Products. No employee, agent, dealer, or other person is authorized to alter this warranty or make any other warranty on behalf of DECKED LLC.

NOTIFICATION PROCEDURES

If the DECKED Product does not conform with the terms of this limited warranty, the original purchaser must promptly notify the Manufacturer in writing upon discovery of the nonconformity. In order to receive remedies under this limited warranty, a warranty claim must have been registered with DECKED LLC by the original purchaser, must describe the nature of the products nonconformity, include a copy of the original sales receipt, invoice, or other proof of purchase and be accompanied with photos or video. Repairs or modifications made to the DECKED Product by other than the Manufacturer or its authorized agent will nullify this limited warranty. Coverage under this limited warranty is conditioned at all times upon the owner's compliance with these required registration, notification, and repair procedures.

Product registration may be performed at: <https://decked.com/register>

Warranty claims must include reciprocal contact information and may be made via certified mail or email to:

DECKED Warranty and Claims

Contact info:

DECKED LLC

PO Box 885

Ketchum, ID 83340

warranty@decked.com

208-806-0251

DECKED.COM | #DECKEDUSA | @DECKEDUSA

