



Installation Instructions: MN5

NISSAN NAVARRA / NP300 1503mm BED LENGTH 2015-CURRENT

IMPORTANT: If installing a **CargoGlide** on top of this drawer system,
DO NOT install the drawer system into your truck yet - SEE INSTRUCTIONS.



SCAN ME

REGISTER YOUR SYSTEM

TOOLS REQUIRED

- 1/4" drive ratchet
- 11mm deep socket
- 1/8" hex wrench
- electric drill
- 11mm drill bit
- 8mm drill bit
- drill stop



SCAN ME

INSTRUCTION VIDEOS

Watch installation videos at DECKED.com/installvideo | Register your system at DECKED.com/register

FOLLOW US:      @DECKEDUSA | #DECKEDUSA

VERSION 8

DECKED.COM | 208.806.0251

RC245

CONTENTS

DECKED carton

- LEFT DECK HALF - 1
- RIGHT DECK HALF - 1
- CENTER VERT - 1
- CABSIDE VERT - 1
- DRAWER - 2
- LEFT AMMO CAN - 1
- RIGHT AMMO CAN - 1
- LEFT STUD - 1
- RIGHT STUD - 1
- AMMO CAN LID - 2
- C-CHANNEL - 2
- RULER - 1
- HARDWARE BOX - 1
- TORSION BRACE - 1
- BOTTLE OPENER - 1

Hardware box - unbagged components

(inside DECKED carton):



HARDWARE box - bagged components

- PREP MN5 - 1
- S1 - 1
- S2 - 1
- N1 - 1
- J8 - 2
- DRAWER 1 - 1
- DRAWER 2 - 1
- WHEELS - 1
- FINAL MID - 1
- PREP-EXTRA - 1
- WASHERS - 1

ASSEMBLY OVERVIEW

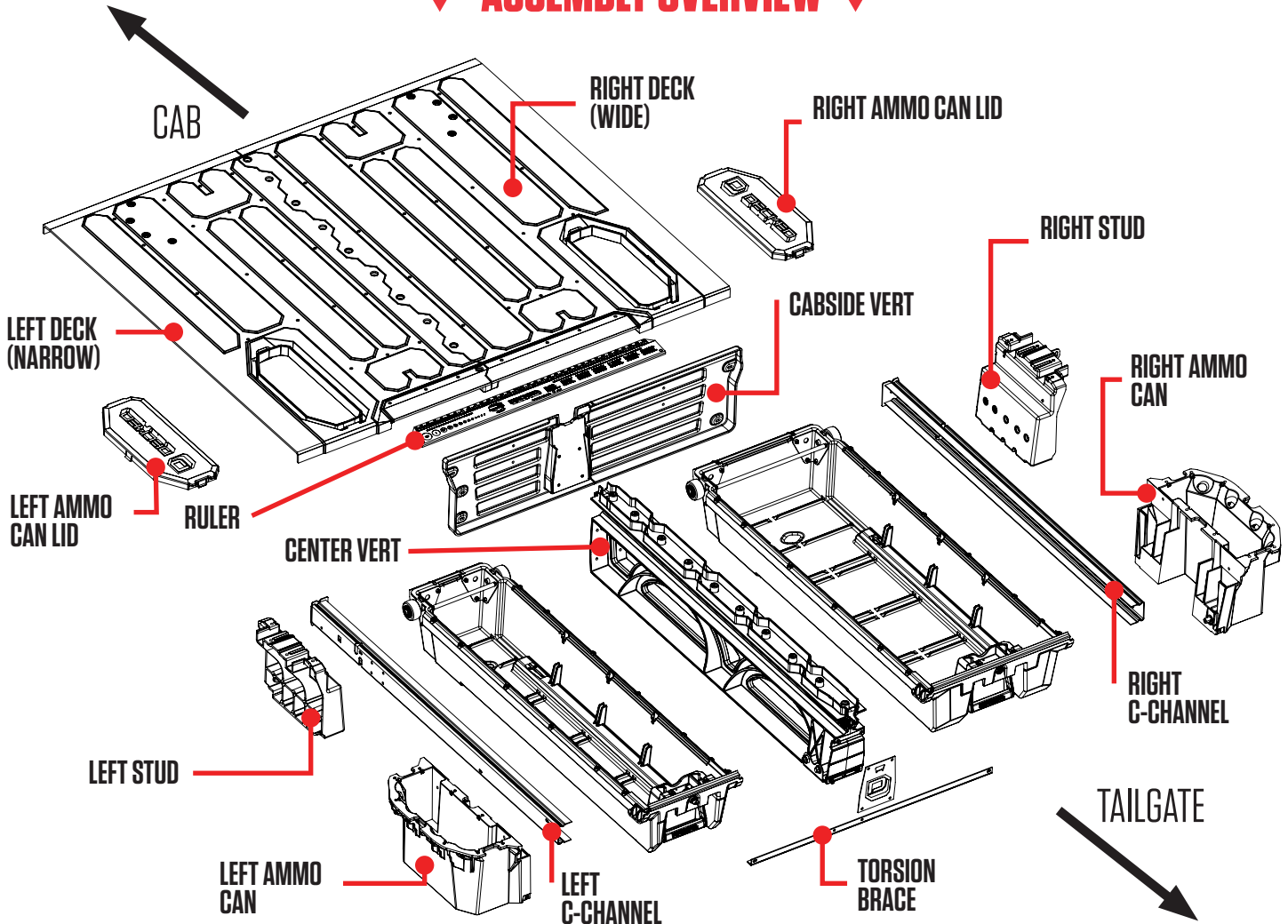

IMPORTANT: If installing a CargoGlide along with this drawer system, DO NOT install the drawer system into your truck yet - SEE INSTRUCTIONS.

▼ HEY! TORQUE BOY: READ BEFORE YOU INSTALL THE DECKED DRAWER SYSTEM ▼

- **DON'T** go rogue on us, please read the instructions.
- Start all bolts with your fingers to avoid cross-threading - you don't want to spin out any inserts.
- **DON'T** over tighten bolts, get em' hand-tight...or you will spin out the inserts.
- **DON'T** use power tools.
- If you don't follow directions and do use power tools, please set the clutch at a very low setting.
- Over-torquing or using an impact wrench will spin out the inserts - we're warning you!
- If you blow it, you can screw the inserts back in from the opposite side with a slotted screwdriver.
- If you really blow it, we've included some repair inserts in the PREP-EXTRA bag - install with a 7/32" hex wrench. Call us if you need more.
- Torque ratings are suggestions - tighten all fasteners until snug.
- Prevent expletive-filled language, watch our detailed installation video or give us a call. We're happy to help!

AMMO CAN DRAIN HOLES

(TO DRILL OR NOT TO DRILL.)

- **Do you use a tonneau or shell over your DECKED system?**
There is no need to drill holes, unless you leave your tonneau open in a deluge.
- **Does your DECKED system live outside?**
The ammo cans will get water in them. You'll need to drill holes in the ammo cans. There are two dimples in the bottom of each ammo can. Drill a 1/2" hole at each dimple. A smaller hole will get clogged. Depending on the system, we may have drilled these for you already.

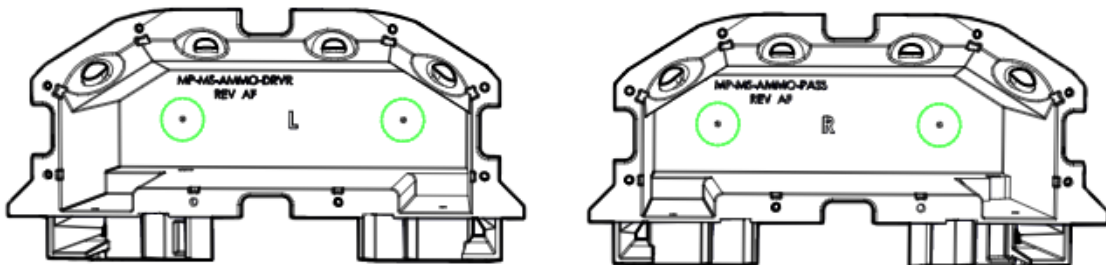

PREP BED: MARK CENTER OF BED

- Use a marking pen or wax pencil to mark a centerline (blue) on the raised center bead.

DETAIL A

MAKE SURE MARK SITS AT LEAST
14" HIGH (SO YOU CAN SEE IT)

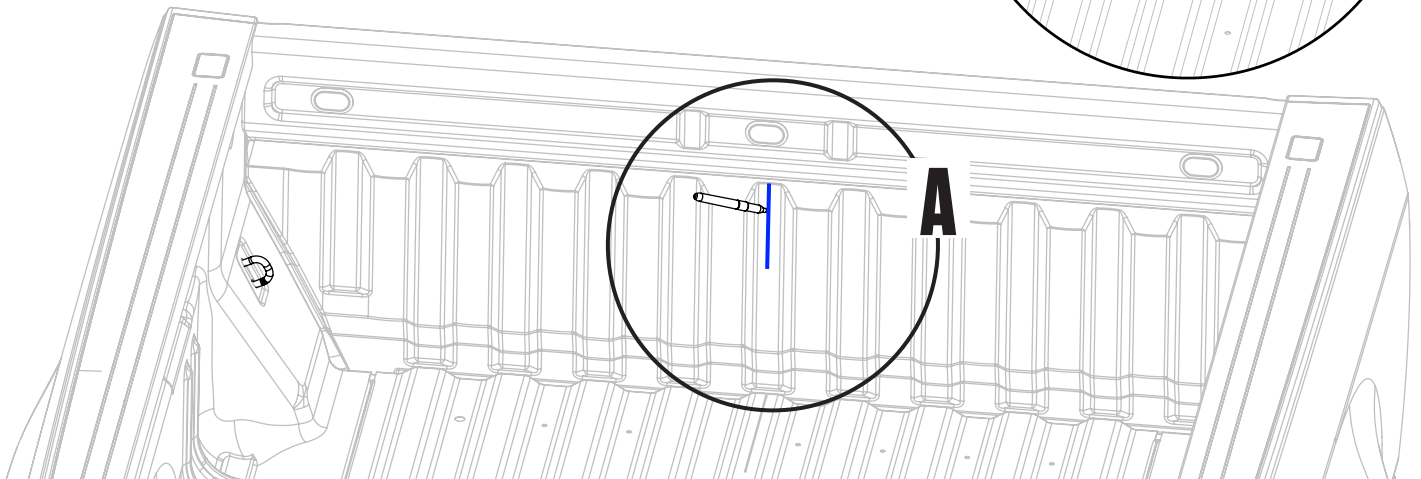
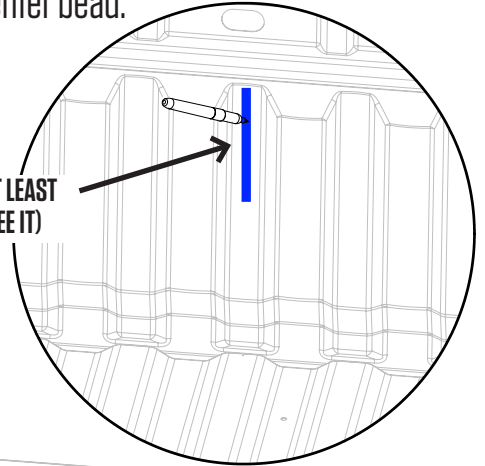

PREP BED: SHIMS

- **2 WIDE SHIMS** and **4 NARROW SHIMS** loose in your hardware kit.
- Using the information below:
 - 1) Clean the bed surface where the shims will be located. Isopropyl alcohol is recommended.
 - 2) Remove tape film and apply shim and apply with pressure.

DETAIL A

Align narrow shim to channel in floor as shown 149mm from rear of bed (red).
Repeat on the right side of bed.

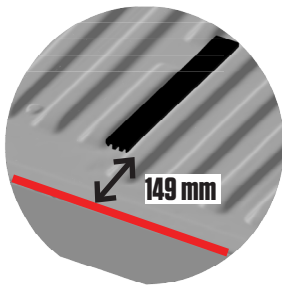

DETAIL C

Align wide shim to channel in floor as shown 60mm from cabside panel of bed (red).
Repeat on the right side of bed.

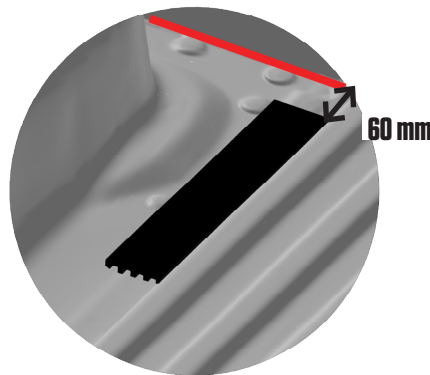

DETAIL D

Align narrow shim to channel in floor as shown 60mm from cabside panel of bed (red).

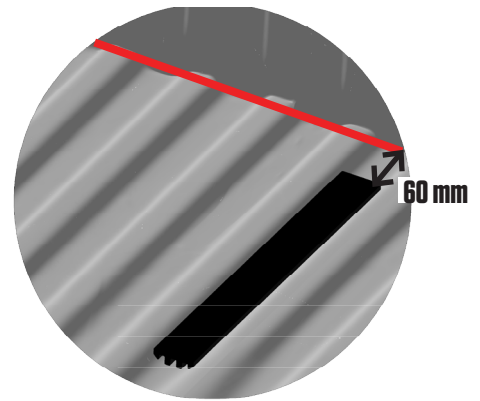

DETAIL B

Align shim to channel in floor as shown 149mm from rear of bed (red).

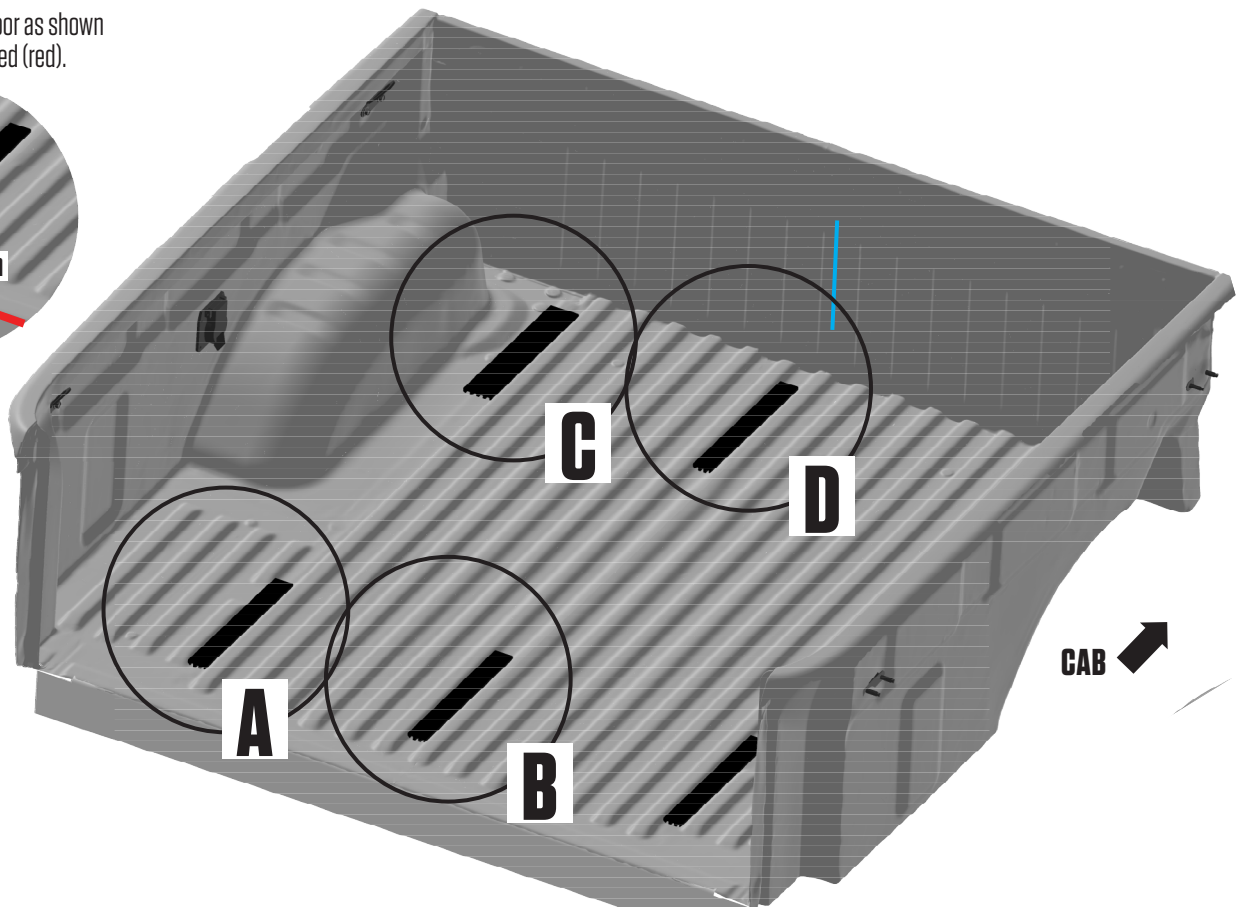
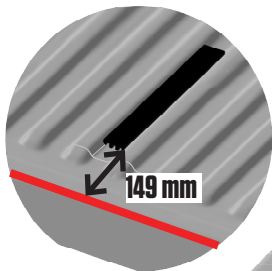

PREP BED: TAILGATE BRACKET

NOTE: You will need to grab a pal for this step (or have incredibly long and flexible arms).

- **STEP 1:** Mark holes as shown.
- **STEP 2:** At both mark locations, drill two 8mm holes. Seal with self-etching primer; **BAG PRIMER.**
- **STEP 3:** Install tailgate bracket; **BAG PREP MN5, BAG WASHERS. IMPORTANT:** Orient bracket hook side towards cab as shown.

NOTE: Bracket must be oriented as shown.

- Repeat other side.

STEP 1

Mark bottom hole location at 150 mm from back of truck bed and 51 mm up from floor. Mark center of top hole location 71 mm from bottom hole center.

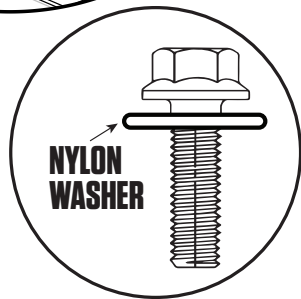
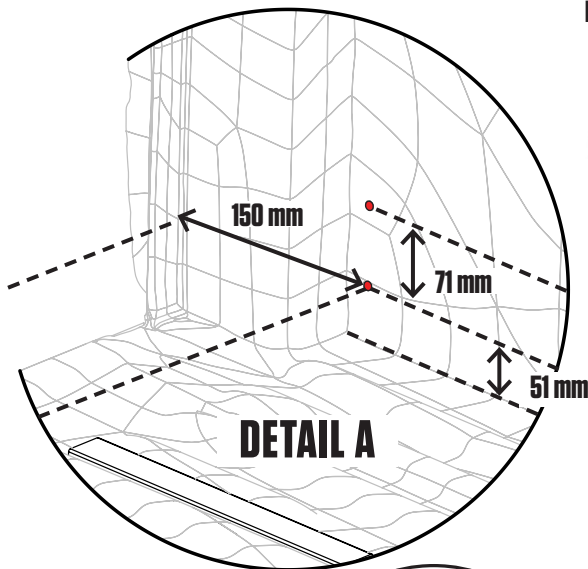

STEP 2

At both mark locations, drill a 8mm hole using a drill stop set to 6mm.



RECOMMENDED TORQUE:
Bolts in labeled bag PREP
MN5 - 6Nm.

STEP 3

Install tailgate bracket and backing plate as shown with two 1" bolts, nylon washers and flanged nuts. Securely tighten.

NOTE: You will need a buddy for this step. **DO NOT** use the slightly shorter dogpoint screws (same as S1 screws).

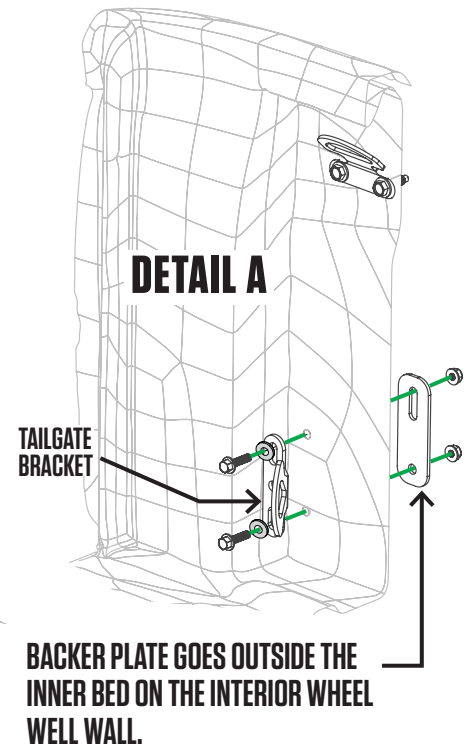

ASSEMBLY: CENTER VERT + CABSIDE VERT

NOTE: Perform the next few steps on a flat surface like a garage floor.

• Attach center vert to cabside vert with four bolts. Alternate to tighten; BAG S1.

NOTE: We've provided a 3/8" socket for the S1 bolts in your bag; BAG PREP MN5.

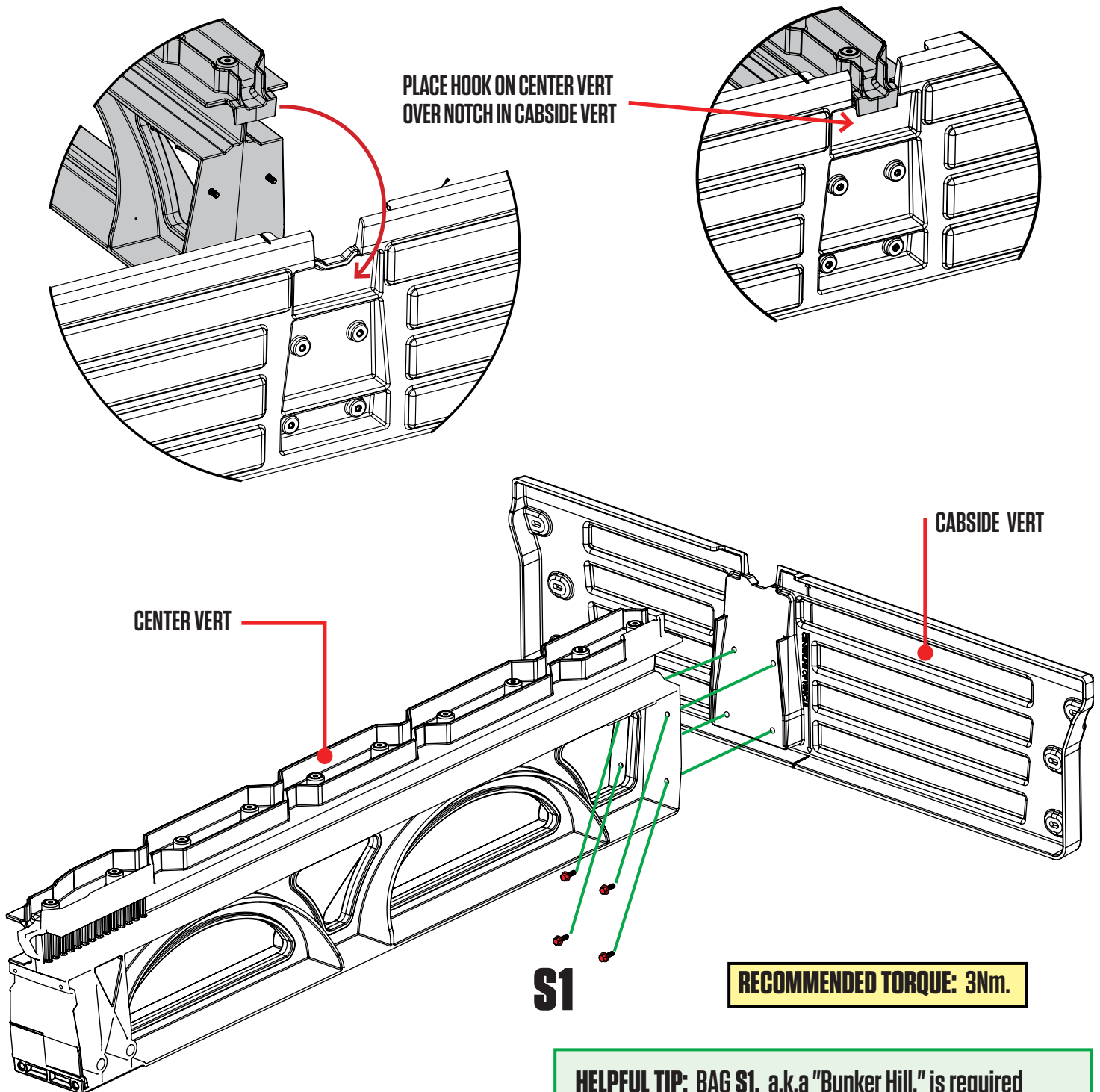

HELPFUL TIP: BAG S1, a.k.a "Bunker Hill," is required for most of the steps, so keep it close! These bolts are highlighted throughout instructions in **RED**.

ASSEMBLY: LOOSELY ATTACH STUDS (YUP)

- **LOOSELY** attach studs to cabside vert with six bolts; BAG S1.

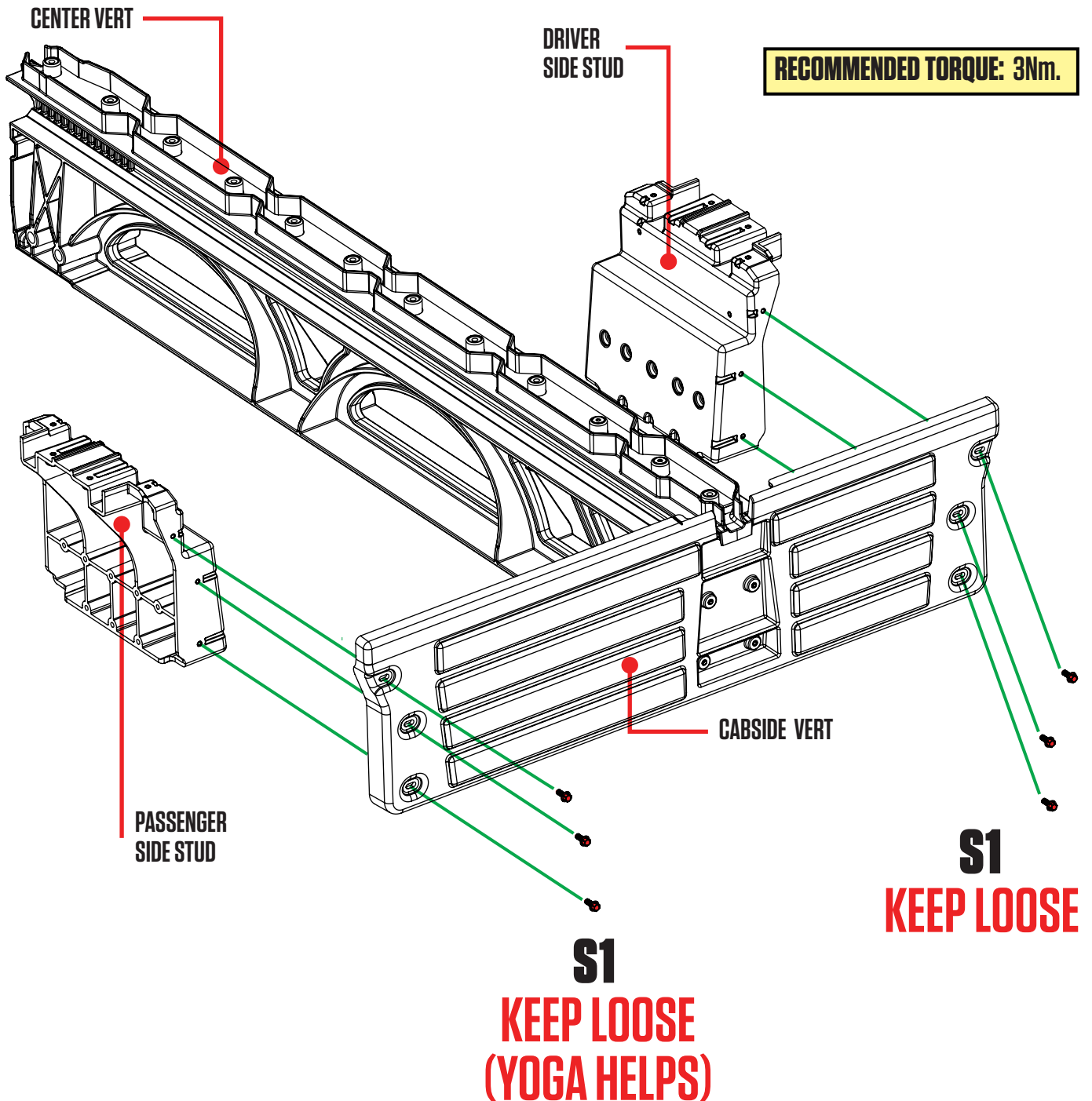

ASSEMBLY: ALIGN & TIGHTEN STUDS (YUP)

NOTE: This step ensures the studs are properly located before tightening bolts. It's important.

- Place ammo cans to support tailgate end of deck panels.
- Lift deck panels on center vert + stud + cabside vert assembly.
- Slide studs around L-R until deck panels are seated.
- **DETAIL A:** Loosely secure four bolts to hold decks onto studs; **BAG S1.**
- Now you can securely tighten the bolts that hold the studs to the cabside vert.



If you will be installing a CargoGlide onto the DECKED drawer system, now is the time to grab your CargoGlide instructions - do not put the drawer system in your truck.

- Unbolt deck from studs, remove deck panels, save bolts, remove ammo cans and set aside for later assembly.

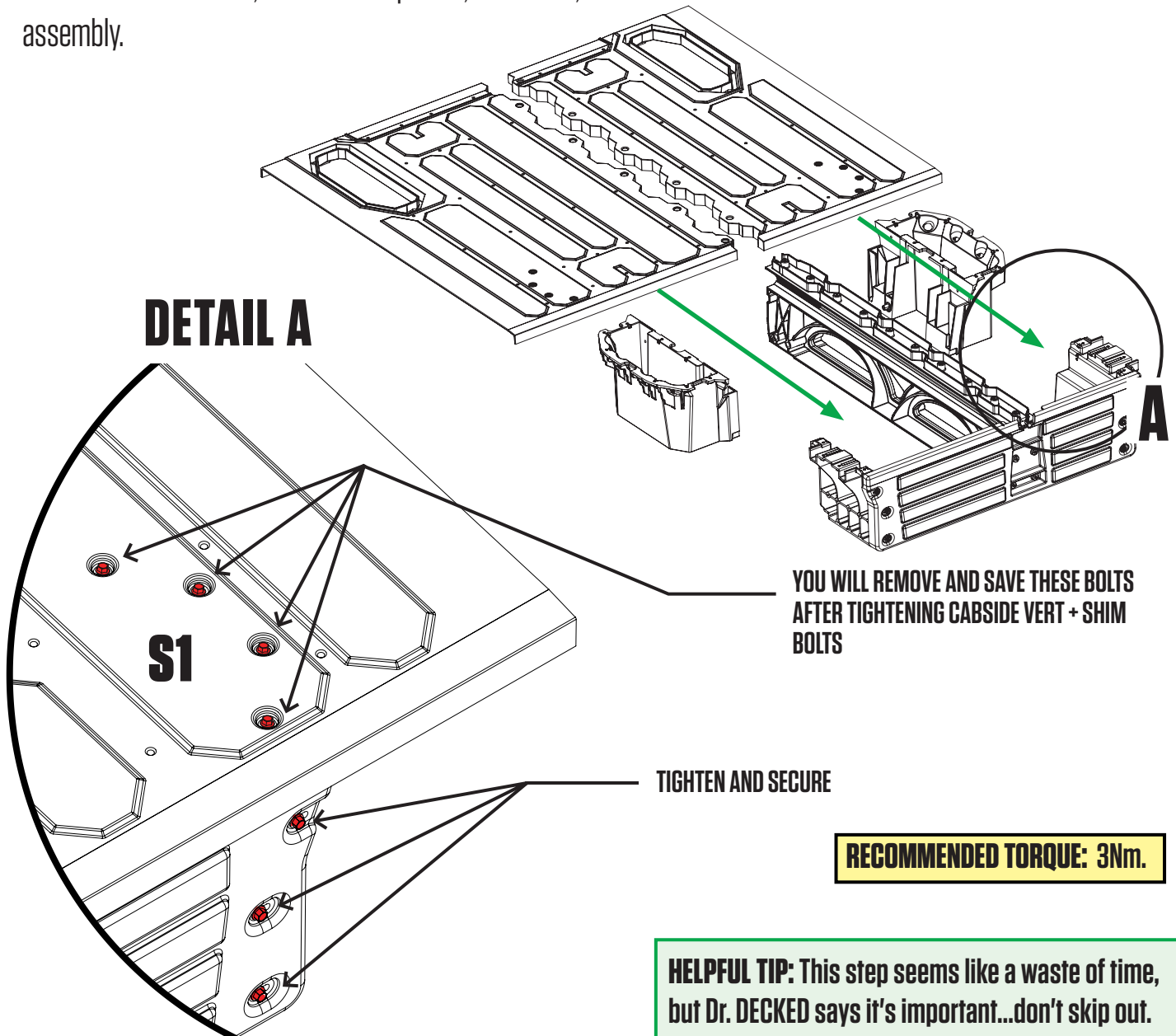

PREP BED: MARK CABSIDE HOLES

- Temporarily place cabside vert + center vert + stud assembly in truck bed.
- **DETAIL B:** Make sure centerline arrow on cabside vert is aligned with your centerline mark (blue).
- **DETAIL A, DETAIL C:** Mark the truck bed via the pre-drilled holes in cabside vert.
- Remove assembly from truck bed.

DETAIL A

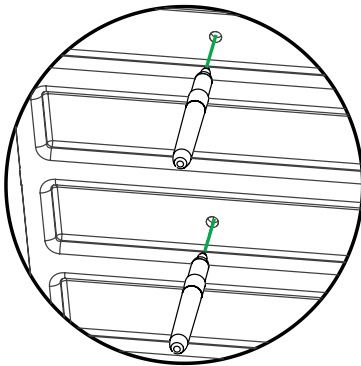

DETAIL B

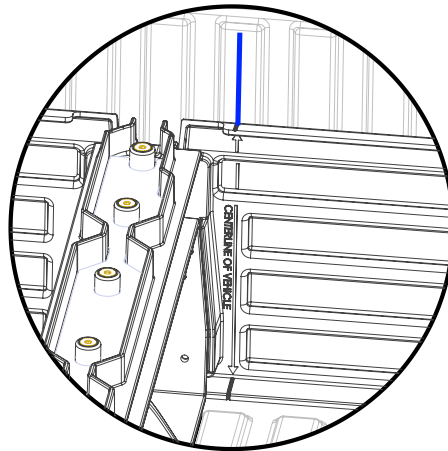

DETAIL C

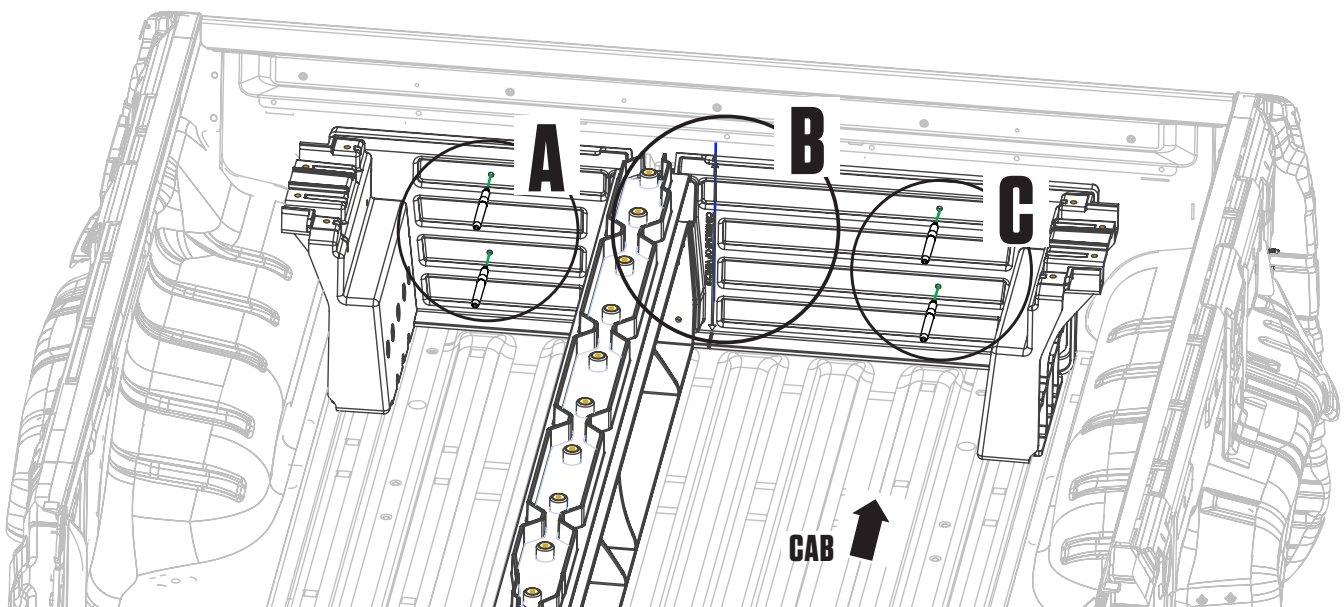
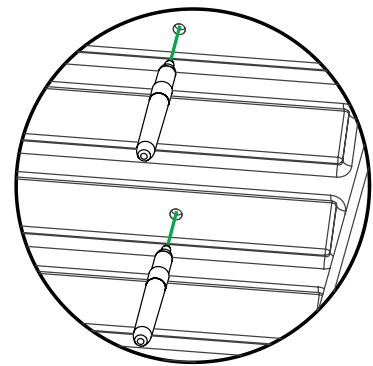

PREP BED: DRILL CABSIDE HOLES

- Drill four 11mm holes at marked locations using a drill stop set to 6mm.

NOTE: To resist corrosion, seal the raw metal edges of the drilled holes with the self-etching primer; BAG PRIMER.

- Install jacknut (yellow) onto jacknut wrench (orange) with 1" placement bolt; BAG PREP MN5.

NOTE: Do not use the slightly shorter dogpoint bolts also found in your PREP BAG.

- **DETAIL A:** Insert jacknut into hole. While holding jacknut wrench, tighten bolt with 3/8" socket until jacknut is fully crimped. Remove placement bolt.
- Repeat on the remaining three holes.

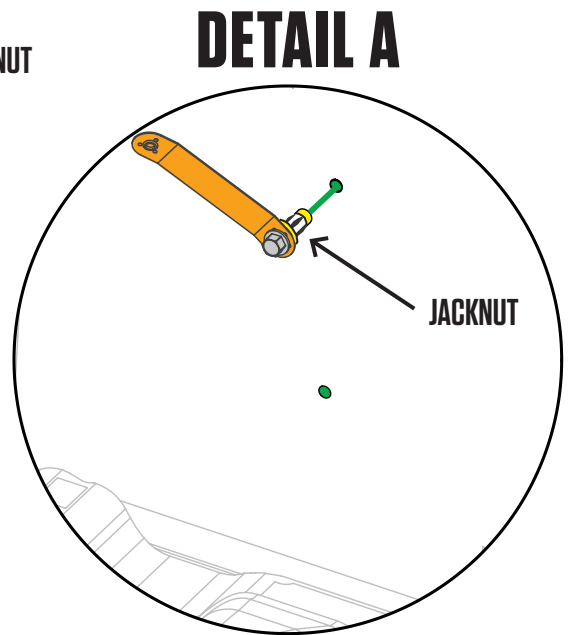
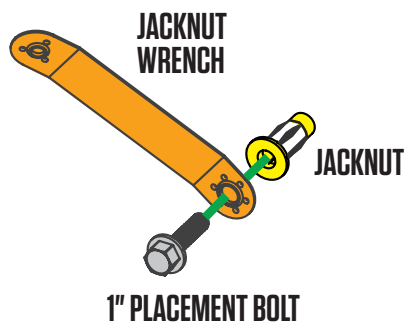

RECOMMENDED TORQUE:
To compress jacknut - 3Nm.

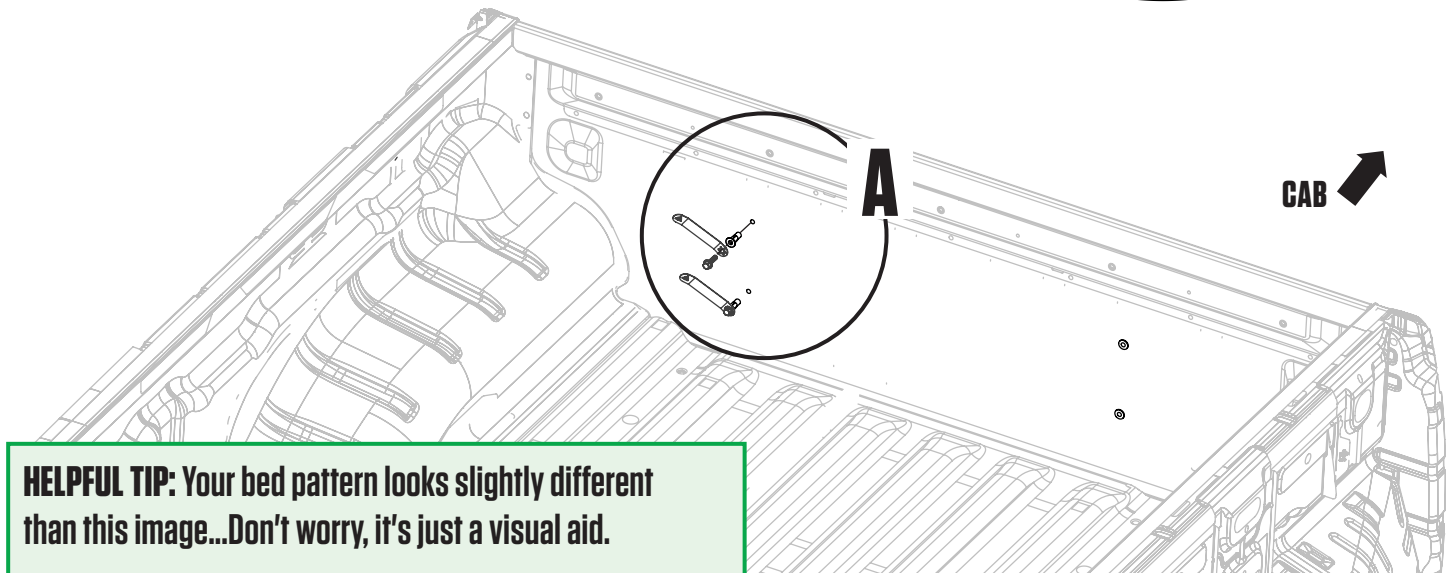

HELPFUL TIP: Your bed pattern looks slightly different than this image...Don't worry, it's just a visual aid.

INSTALL: MOUNT ASSEMBLY

- Place cabside vert + center vert + stud assembly in truck bed.
- Secure assembly using two 22mm screws and two washers; BAG PREP MN5.

NOTE: These are the same bolts as the dogpoint bolts in your S1 BAG.

- Repeat other side.

DETAIL A

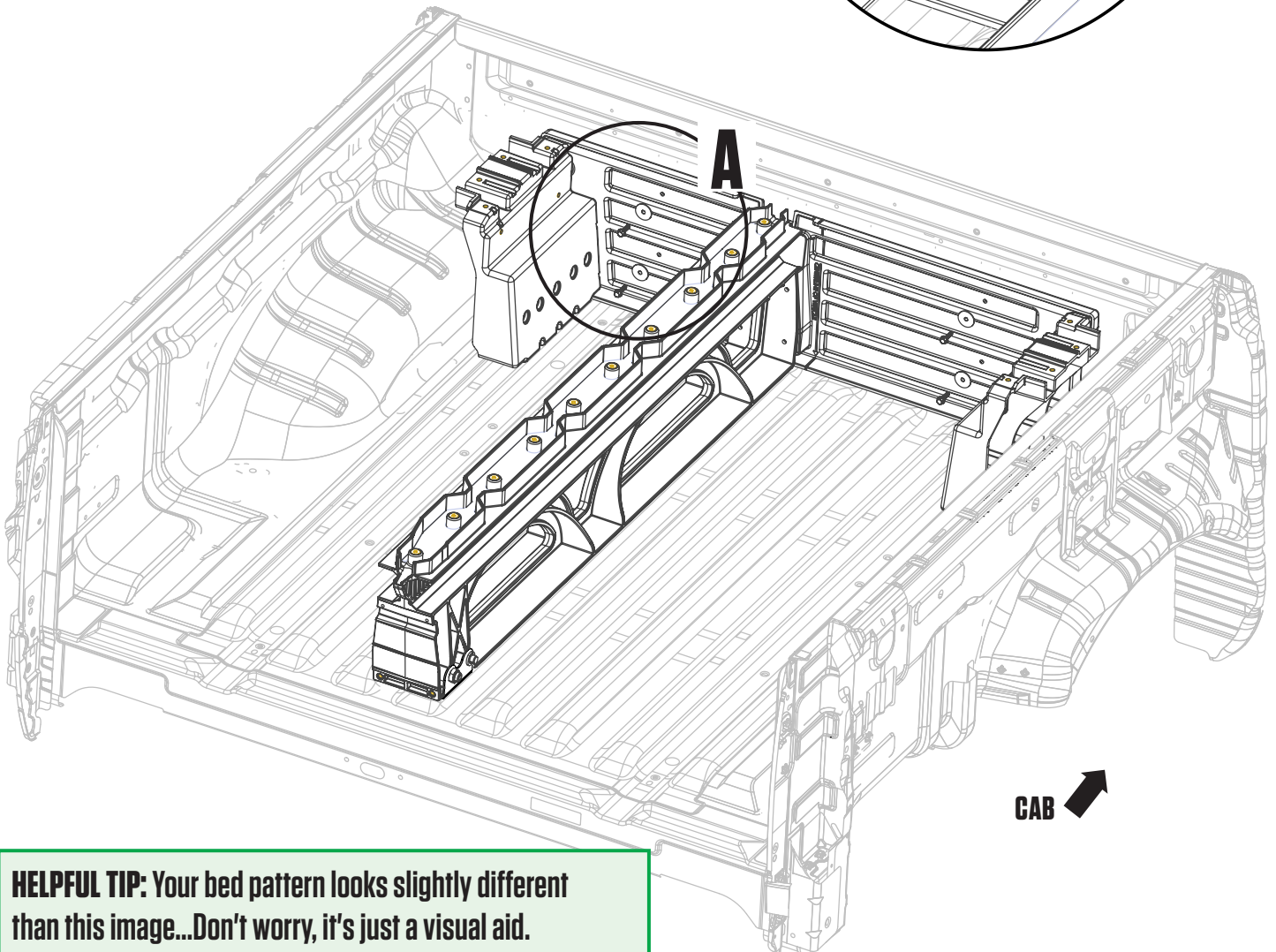
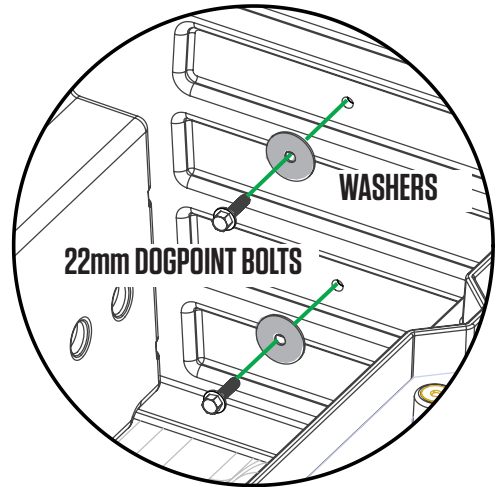

HELPFUL TIP: Your bed pattern looks slightly different than this image...Don't worry, it's just a visual aid.

INSTALL: C-CHANNELS

IMPORTANT: There is a left and right ammo can. The inside of each ammo can is marked L or R.

- Loosely place left side ammo can at tailgate corner of bed.
- Place left side C-channel on ledge of stud and ammo can with end plate cabside.
- Install nylon washer only onto 4 S1 bolts and all S2 bolts; **BAG WASHERS**.
- **DETAIL A:** Insert two bolts through C-channel into ammo can and loosely fasten with nut; **BAG S2, BAG N1**.
- **DETAIL B:** Tightly attach C-channel to stud; **BAG S1**.
- Repeat on right side.

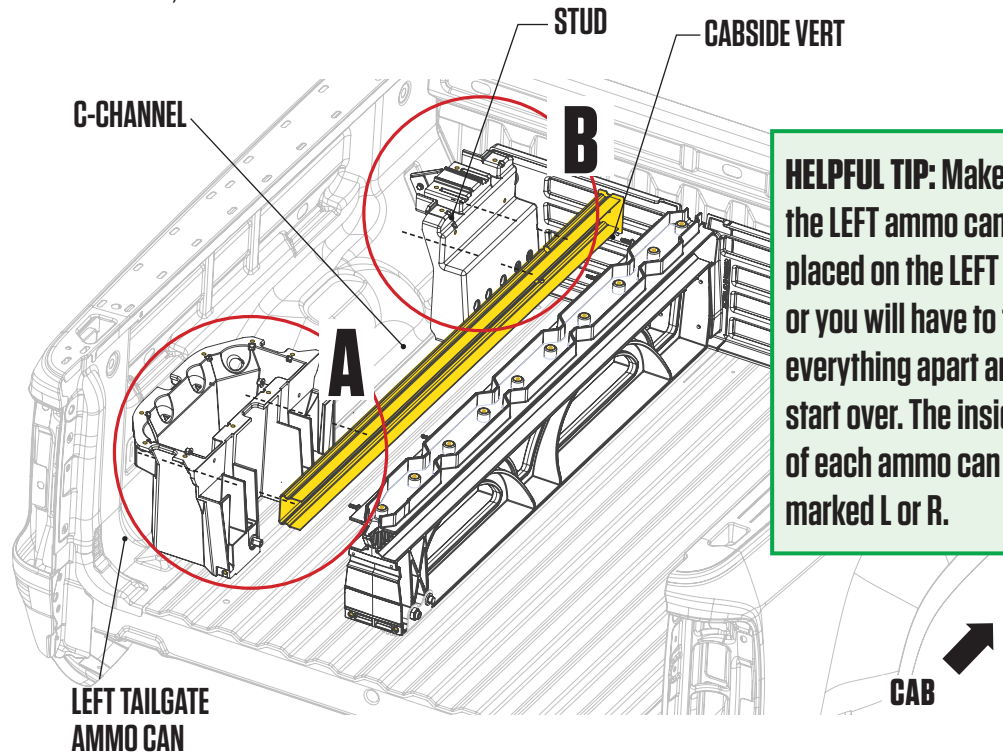

HELPFUL TIP: Make sure the LEFT ammo can is placed on the LEFT side, or you will have to take everything apart and start over. The inside of each ammo can is marked L or R.

DETAIL A KEEP LOOSE

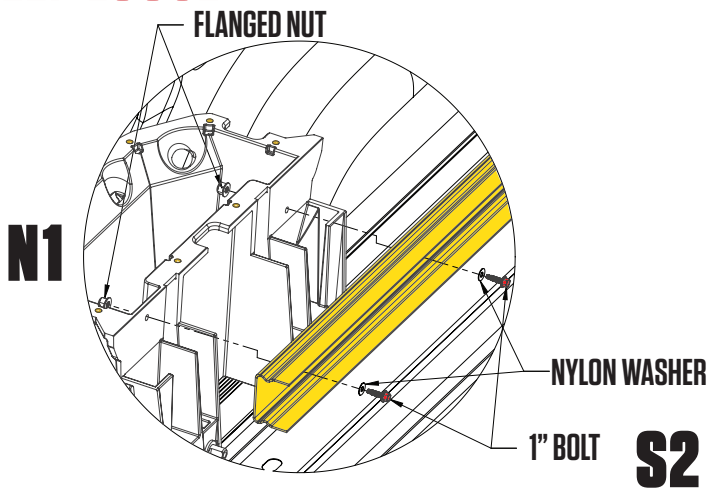

DETAIL B TIGHTEN

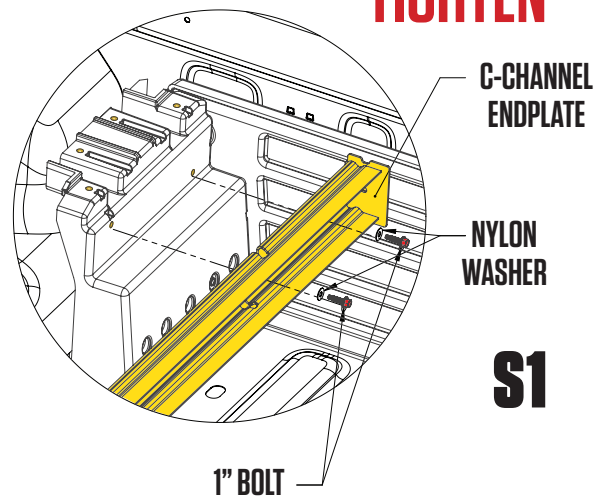

RECOMMENDED TORQUE: Bolts in S1 and S2 BAG - 3Nm.

INSTALL: DECK HALVES

- Loosely place deck panel on side stud, center vert and ammo can.
- Shift ammo can forward, rearward, L-R, as necessary to align with fully seated deck panel.
- Loosely assemble:
 - Five or six bolts (depends on bed length - NO WASHERS) through deck panel into center vert; **BAG S1**.
 - Four bolts with nylon and rubber washers installed as shown through deck panel into stud; **BAG S1, BAG WASHERS**.
 - Eight bolts with nylon and rubber washers installed as shown through deck panel into ammo can; **BAG S1, BAG WASHERS**.
 - Tighten all **S1** bolts.
 - **Securely tighten C-channel/ammo can nuts and bolts.**
- Repeat other side (making sure you don't forget to securely tighten C-channel/ammo can nuts and bolts).
- We have included extra washers - don't worry if you have leftovers.

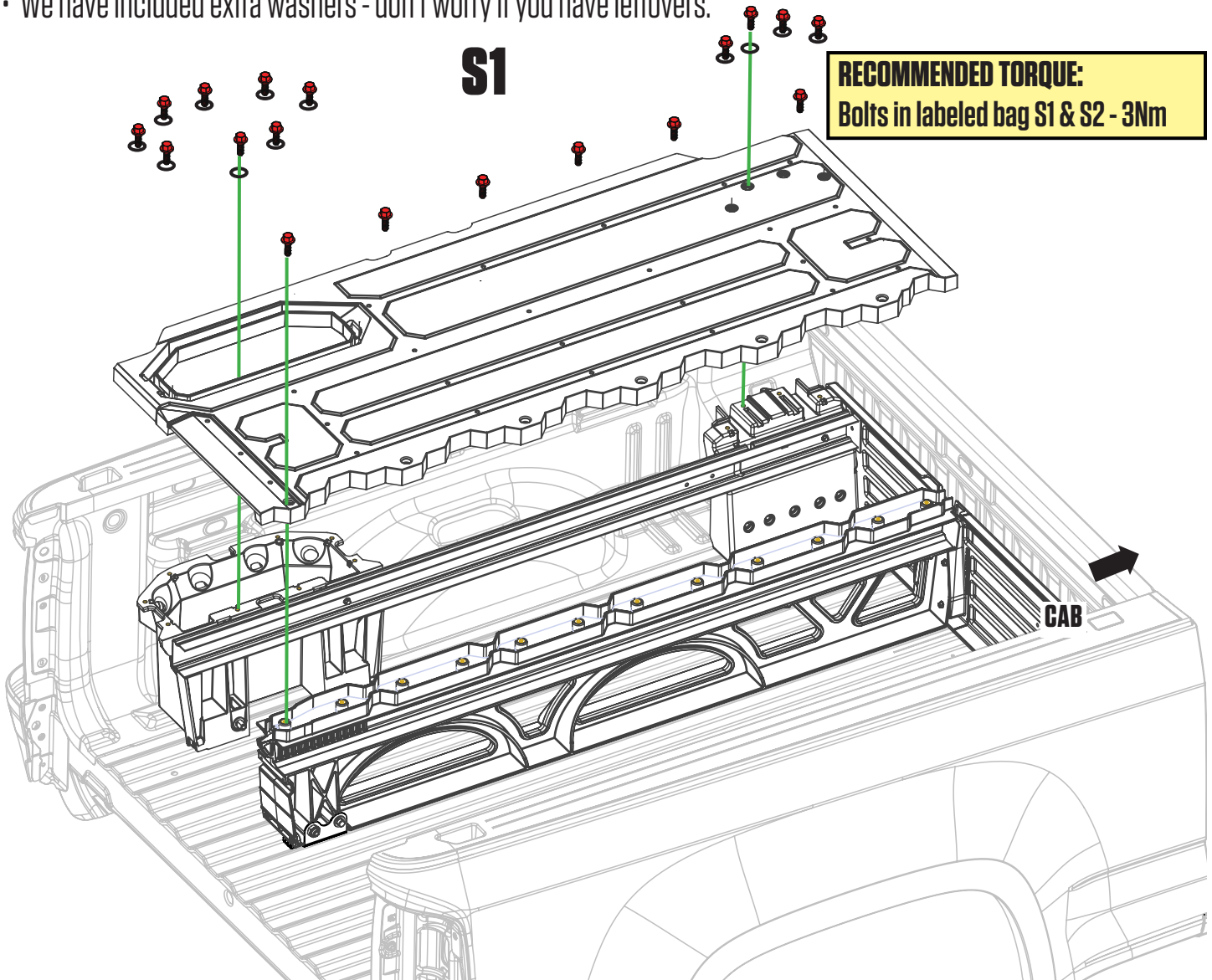
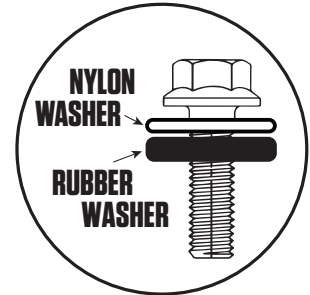

DRAWERS: BRACKETS + WHEELS

- Each drawer has a left and a right bracket. Bolt brackets into place via bottom two holes in bracket with 19mm length screws. Use the 50mm length screws for the upper cabside wall hole in bracket; **BAG DRAWER 1**.
- Install a tube brace in each drawer with two 19mm length screws; **BAG DRAWER 1**, **BAG DRAWER 2**.
- Attach wheels onto drawer brackets with a 7/32" hex wrench; **BAG WHEELS**

NOTE: We've provided a hex wrench in your BAG PREP MN5.

RECOMMENDED TORQUE:
Bolts in labeled bags DRAWER 1 and DRAWER 2 - 3Nm.
Bolts in labeled bag WHEELS - 10Nm.

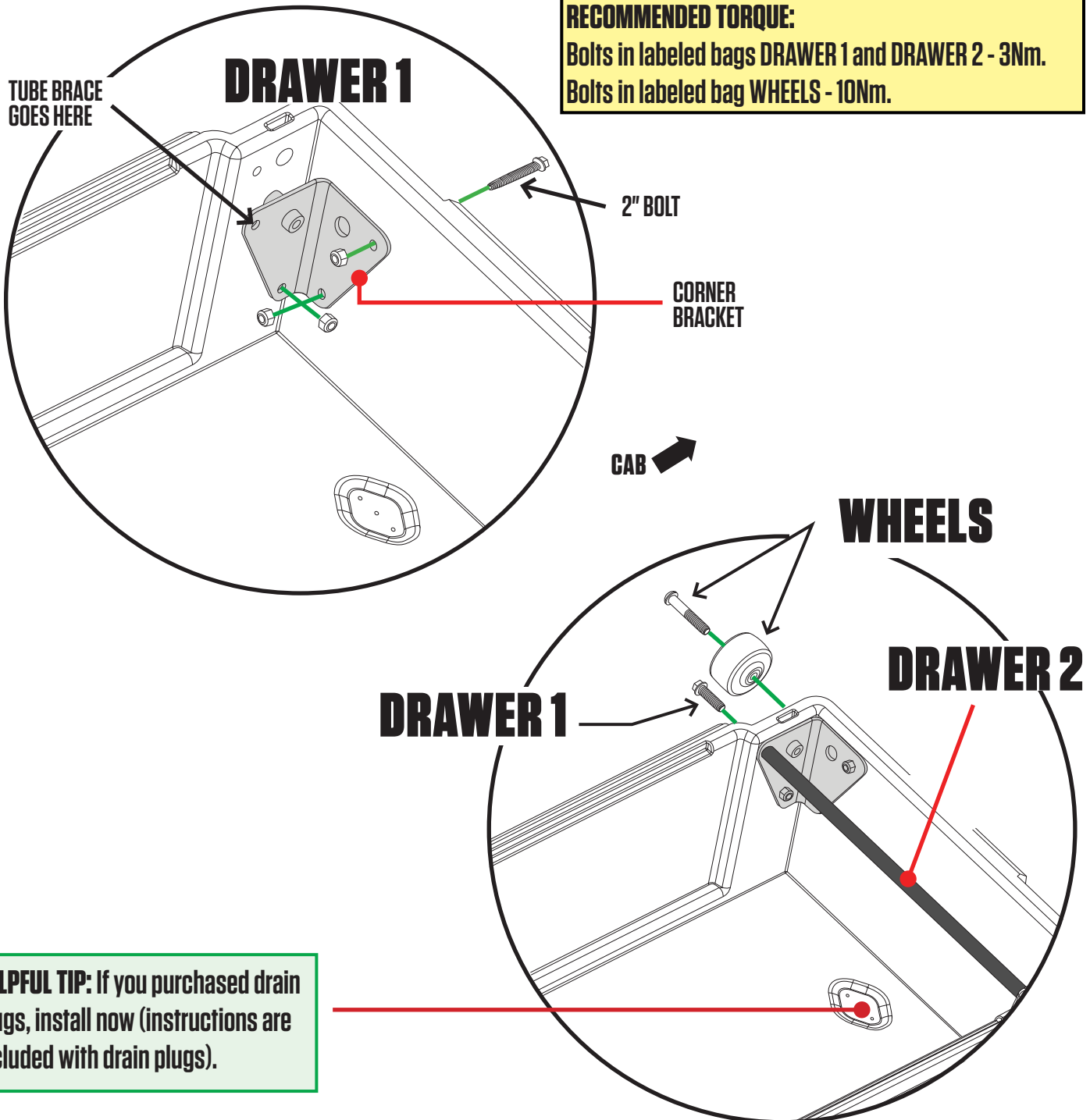

DRAWERS: AXLE WHEELS + WEATHERSTRIPS

- Slide narrow drawer into driver side drawer cavity. **NOTE: It is easier to fully install narrow drawer first.**
- **DETAIL A:** Install two tailgate wheels onto narrow drawer axles with a 7/32" hex wrench; **BAG WHEELS.**
- Repeat with wide drawer.
- **DETAIL B:** Install weatherstrips on top of drawer edges **WITH WIPER BLADE POINTING TOWARD DRIVER.**
IMPORTANT: Facing the weatherstrip the wrong way will funnel water into drawer: DUH!

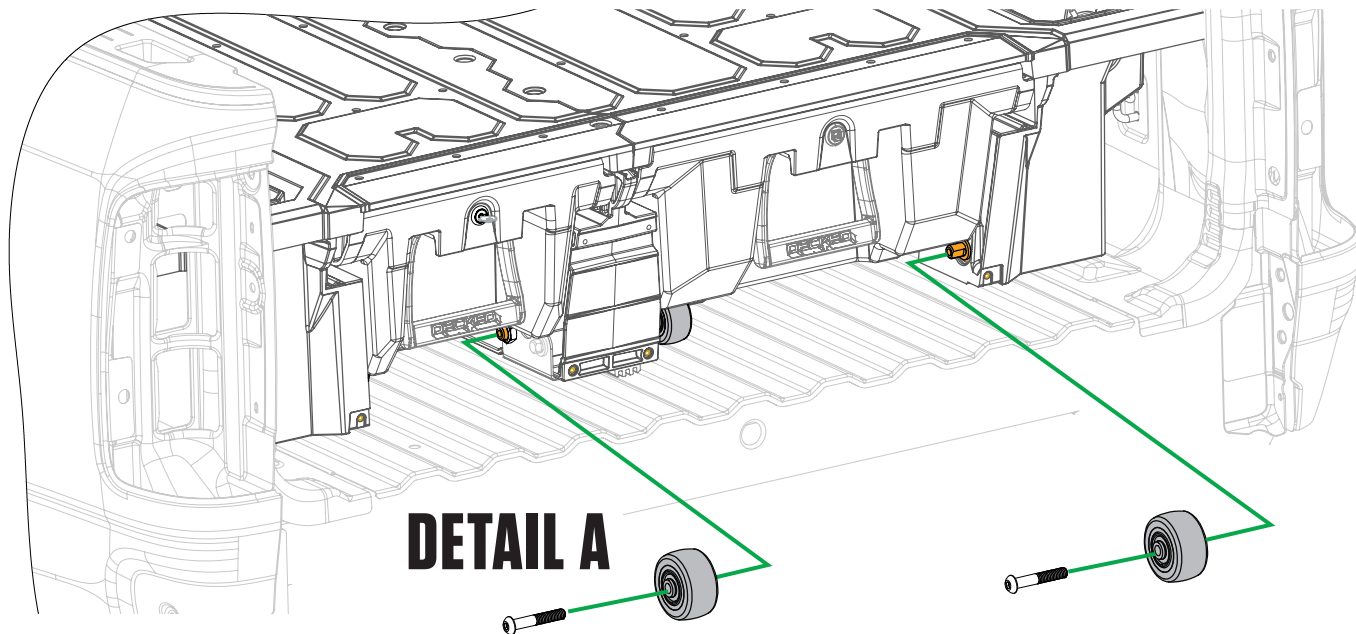

RECOMMENDED TORQUE:
Wheel bolts - 10Nm.

HELPFUL TIP: To make this step easier, jam a 2" piece of material under drawer, or get your pal to pinch the drawer up to the deck to give you better leverage.

HELPFUL TIP: Cut weatherstrips if they overhang.

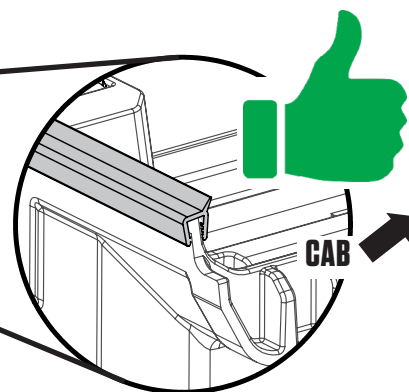
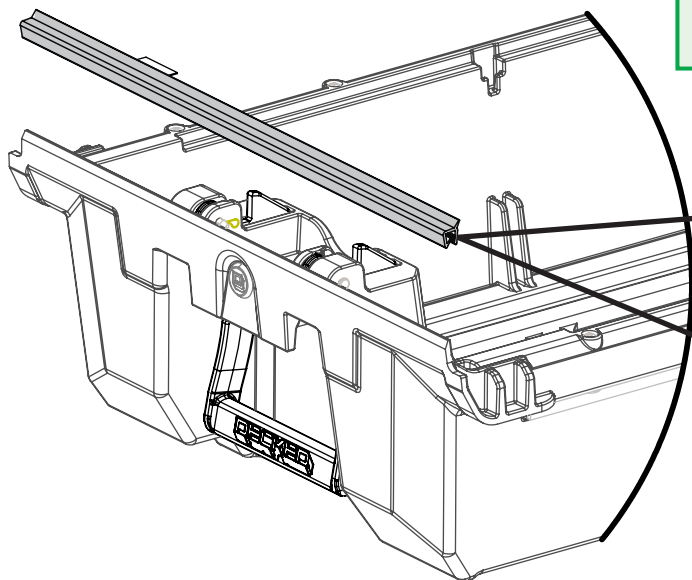

DETAIL B

THE FUN STUFF: TORSION BRACE + BOTTLE OPENER



- Slide torsion brace under center vert and tailgate ammo cans.
- Loosely install:
 - Two 1/2" length bolts through upper holes in bottle opener into center vert; **BAG FINAL MID.**
 - Two bolts with nylon washers through the end holes in torsion brace into ammo cans; **BAG S1.**
 - Two bolts with nylon washers through the bottom bottle opener holes and torsion brace into center vert; **BAG S1.**
- Align bottle opener to edges of center vert and tighten four bottle opener bolts.
- Tighten end bolts into tailgate ammo cans.

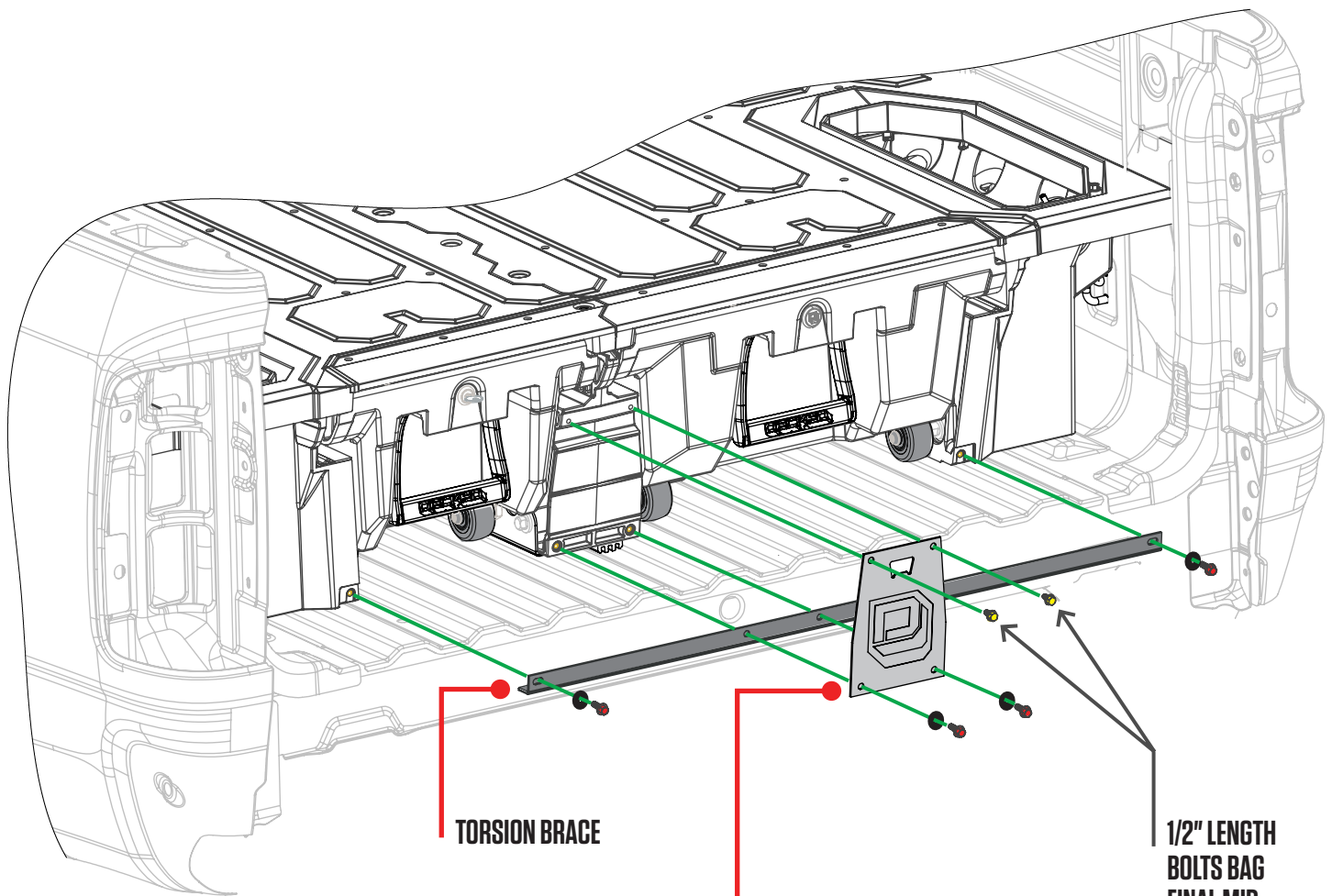

HELPFUL TIP: Bottle opener goes outside of torsion brace.

RECOMMENDED TORQUE:
Bolts in labeled bag S1 - 10Nm.

INSTALL: J-HOOKS

- Install J-hook onto tie down bracket and through the hole closest to the **tailgate** in ammo can; **BAG J8**.
- Install winged-spherical nut-washer, round side down, onto J-hook and partially tighten using your fingers only.
IMPORTANT: Keep J-hook assembly loose.
- Repeat other side.
- Tighten the J-hooks, but **DO NOT OVER TIGHTEN!** Make sure the gap between the side wall of the bed and the deck is equal on both sides.
- Install bolt thread protectors on J-hook ends; **BAG FINAL MID.**

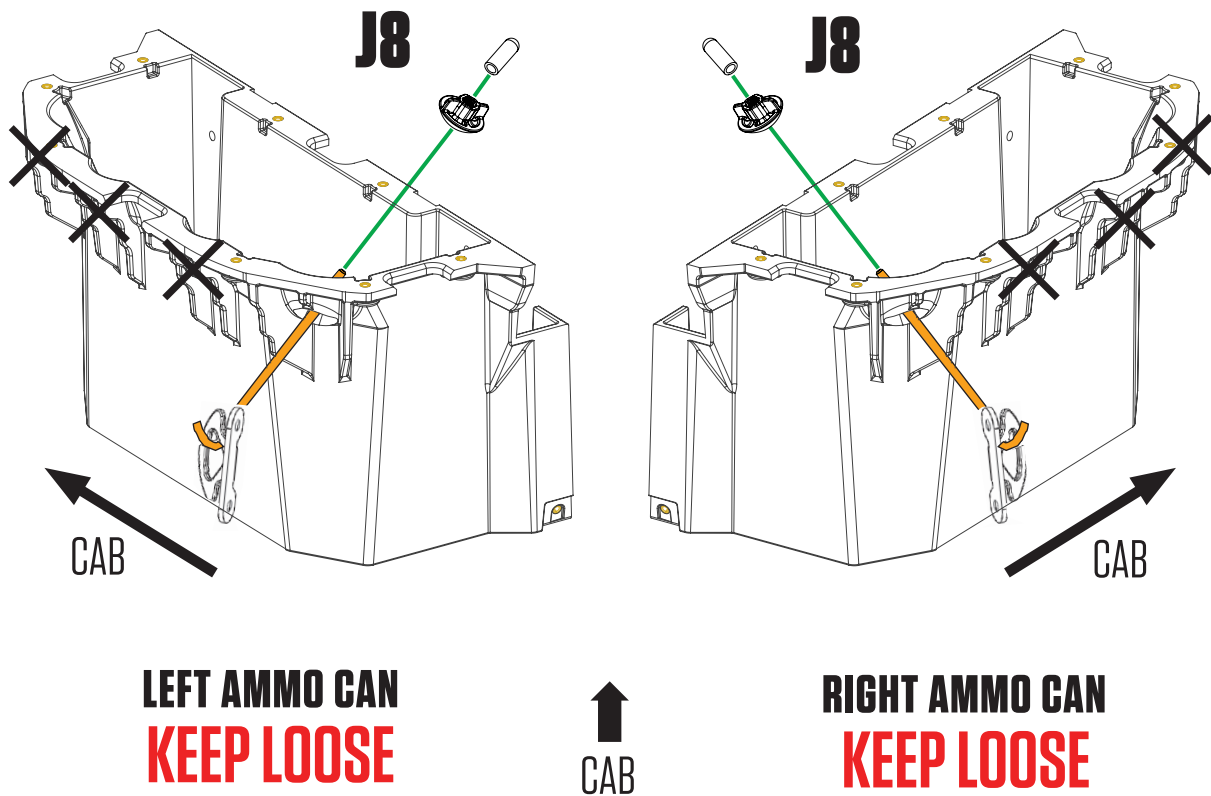

HELPFUL TIP: Make sure the hooks open toward tailgate.

IMPORTANT: You're almost there, so get your favorite beverage ready to crack open in the bottle opener and make a toast to your truck. When finished, immediately post a photo of your significant other, child or canine (in no order of significance - please someone show us your pet alligator) appreciating your accomplishment. Add hashtag #DECKEDUSA | @DECKEDUSA.

FINAL STEPS: THE RULER

- Install ruler with six 1/8" hex screws; **BAG FINAL MID**. Start screws with fingers to avoid cross-threading. Tighten just until snug. Overtightening will strip the inserts.

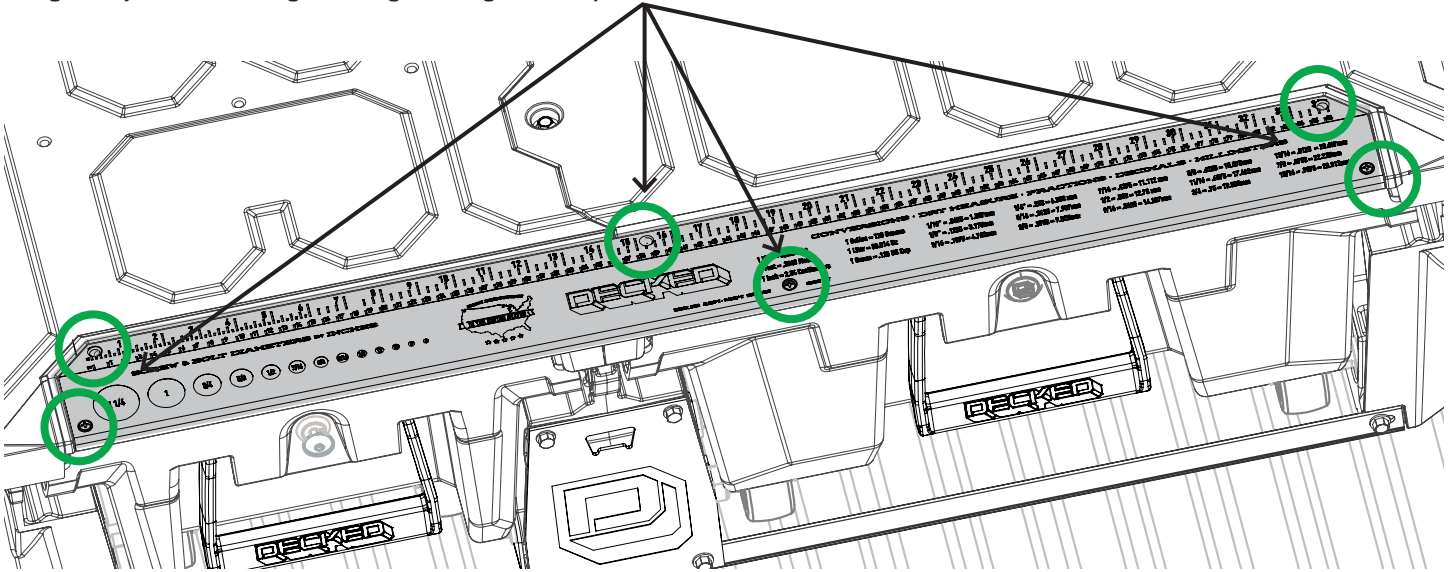

FINAL STEPS: AMMO CAN LIDS

- **DETAIL A:** Ammo can lids are left (marked L) and right (marked R) side specific.
- **DETAIL B:** Holding lid in orientation shown, insert tab on tailgate end of ammo can lid and push the cabside end of lid down to secure. Don't be afraid to push down hard.
- Insert lock hole plugs, unless you are fitting the optional drawer locks, in which case install drawer locks now (instructions with locks); **BAG FINAL MID**.

DETAIL A

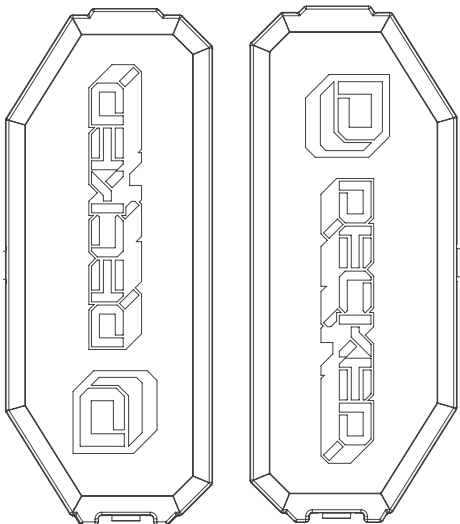

LEFT AMMO
CAN LID

RIGHT AMMO
CAN LID

DETAIL B

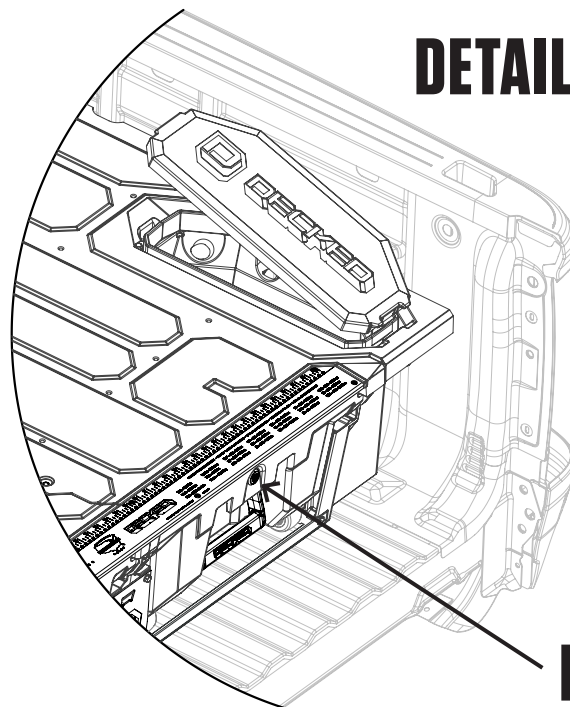

FINAL MID

DECKED Products – Limited Lifetime Warranty

(Valid on DECKED Products purchased on or after 8/1/2021)

DECKED LLC, (the “Manufacturer”) warrants the original purchaser only that DECKED Truck and Van Products (The “DECKED” Product) will be free from defects in material and workmanship from the date of purchase and continuing for the expected lifetime of the DECKED Product. The DECKED Product must be registered by the original purchaser with DECKED, LLC via its website at, www.decked.com/register, and a copy of the original sales receipt must be supplied to the Manufacturer at the time a warranty claim is made. This warranty terminates if the original purchaser transfers the DECKED Product to any other person or vehicle.

WHAT IS COVERED

All DECKED Products identified above on or after August 1, 2021

DECKED’s Limited Lifetime Warranty applies to US and Canadian customers only. International shipments are covered by DECKED’s 3 Year Limited Warranty.

WHAT WE WILL DO TO CORRECT PROBLEMS

Subject to the limitations and exclusions described in this limited warranty, the Manufacturer will remedy defects in workmanship or materials by providing one of the following remedies at its option and without charge to the original purchaser for parts: (a) repairing the defective portion of the DECKED Product or (b) replacing the entire DECKED Product. In addition, the Manufacturer may elect at its option not to repair or replace the DECKED Product, but rather issue to the original purchaser a refund equal to the purchase price paid for the DECKED Product or a credit to be used towards the purchase of a new DECKED Product.

WHAT IS NOT COVERED

This limited warranty expressly excludes:

- Damage or defects caused by normal wear and tear, cosmetic rust, scratches, accidents, unlawful vehicle operation, installation in a non-supported vehicle or installed in a vehicle which does not match the DECKED Product’s SKU-intended fitment or use, or modification of the product, or any types of repair of a DECKED Product other than those authorized or provided by the Manufacturer.
- Damage or defects resulting from conditions beyond the Manufacturer’s control and specifications including, but not limited to modification, misuse, overloading, or failure to assemble, install or use the DECKED Product in accordance with the Manufacturer’s written instructions or guidelines included with the DECKED Product or separately made available to the original purchaser.
- Damage to the contents of the DECKED Product or vehicle.
- TO THE EXTENT PERMITTED BY LAW, IN NO EVENT SHALL THE MANUFACTURER BE LIABLE FOR ANY INCIDENTAL, SPECIAL, INDIRECT, OR CONSEQUENTIAL DAMAGES, INCLUDING ECONOMIC LOSS, WHETHER RESULTING FROM NONPERFORMANCE, USE, MISUSE, OR INABILITY TO USE THE DECKED PRODUCT OR THE MANUFACTURER’S NEGLIGENCE.

NO OTHER EXPRESS WARRANTY APPLIES

This Limited Lifetime Warranty is the sole and exclusive warranty for DECKED Products. No employee, agent, dealer, or other person is authorized to alter this warranty or make any other warranty on behalf of DECKED LLC.

NOTIFICATION PROCEDURES

If the DECKED Product does not conform with the terms of this limited warranty, the original purchaser must promptly notify the Manufacturer in writing upon discovery of the nonconformity. In order to receive remedies under this limited warranty, a warranty claim must have been registered with DECKED LLC by the original purchaser, must describe the nature of the products nonconformity, include a copy of the original sales receipt, invoice, or other proof of purchase and be accompanied with photos or video. Repairs or modifications made to the DECKED Product by other than the Manufacturer or its authorized agent will nullify this limited warranty. Coverage under this limited warranty is conditioned at all times upon the owner’s compliance with these required registration, notification, and repair procedures.

Product registration may be performed at: <https://decked.com/register>

Warranty claims must include reciprocal contact information and may be made via certified mail or email to:

DECKED Warranty and Claims

Contact info:

DECKED LLC

PO Box 885

Ketchum, ID 83340

warranty@decked.com

208-806-0251

DECKED.COM | #DECKEDUSA | @DECKEDUSA

