



Installation Instructions:

MH1/MH2

HOLDEN / ISUZU

COLORADO CREW / D-MAX CREW

1530mm BED LENGTH

COLORADO KING / D-MAX KING

1795mm BED LENGTH

HOLDEN: 2012-2020 / ISUZU: 2012-2019

**IMPORTANT:** If installing a **CargoGlide** on top of this drawer system, **DO NOT** install the drawer system into your truck yet - **SEE INSTRUCTIONS.**



SCAN ME

REGISTER YOUR SYSTEM

TOOLS REQUIRED

- 1/4" drive ratchet
- 7/16" socket
- 1/8" hex wrench
- electric drill
- 11mm drill bit
- drill stop



SCAN ME

INSTRUCTION VIDEOS

Watch short installation videos at [www.decked.com/video](http://www.decked.com/video) | Register your system at [www.decked.com/register](http://www.decked.com/register)

FOLLOW US:      @DECKEDUSA | #DECKEDUSA

VERSION 10

DECKED.COM | 208.806.0251

RC241

# CONTENTS



DECKED carton contents:



HARDWARE box contents:

PREP MH1/MH2 - 1
SHIMS - 6
SL1 - 1
B2 - 1
N1 - 1
J8 - 2
DRAWER 1 - 1
DRAWER 2 - 1
WHEELS - 1
FINAL MS - 1
PREP-EXTRA - 1
PRIMER - 1
WEATHERSTRIPS - 2
BOTTLE OPENER - 1

## ASSEMBLY OVERVIEW

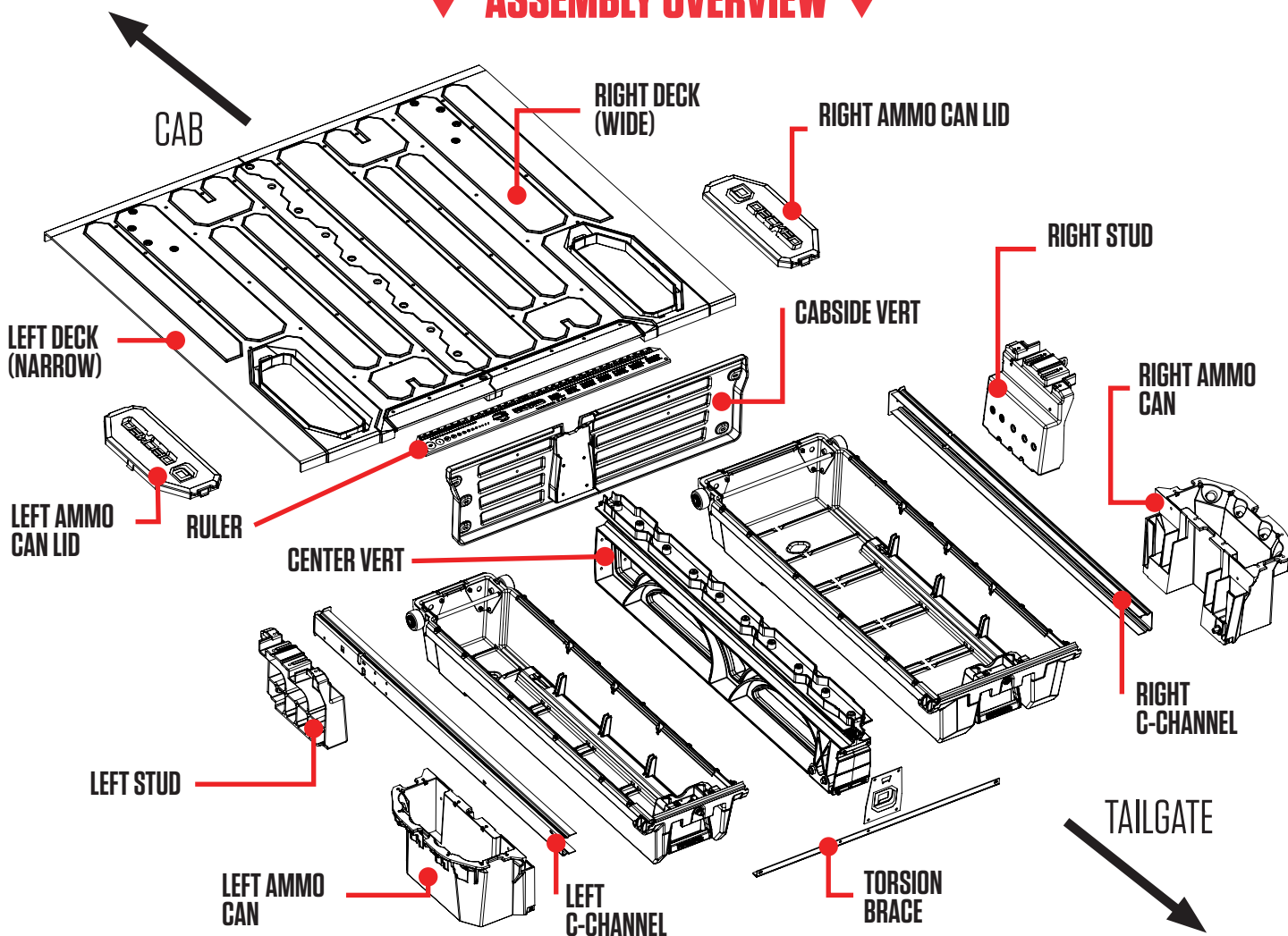

**IMPORTANT: If installing a CargoGlide along with this drawer system, DO NOT install the drawer system into your truck yet - SEE INSTRUCTIONS.**

**▼ HEY! TORQUE BOY: READ BEFORE YOU INSTALL THE DECKED DRAWER SYSTEM ▼**

- **DON'T** go rogue on us, please read the instructions.
- Start all bolts with your fingers to avoid cross-threading - you don't want to spin out any inserts.
- **DON'T** over tighten bolts, get em' hand-tight...or you will spin out the inserts.
- **DON'T** use power tools.
- If you don't follow directions and do use power tools, please set the clutch at a very low setting.
- Over-torquing or using an impact wrench will spin out the inserts - we're warning you!
- If you blow it, you can screw the inserts back in from the opposite side with a slotted screwdriver.
- If you really blow it, we've included some repair inserts in the PREP-EXTRA bag - install with a 7/32" hex wrench. Call us if you need more.
- Torque ratings are suggestions - tighten all fasteners until snug.
- Prevent expletive-filled language, watch our detailed installation video or give us a call. We're happy to help!

## AMMO CAN DRAIN HOLES

(TO DRILL OR NOT TO DRILL.)

- **Do you use a tonneau or shell over your DECKED system?**  
There is no need to drill holes, unless you leave your tonneau open in a deluge.
- **Does your DECKED system live outside?**  
The ammo cans will get water in them. You'll need to drill holes in the ammo cans. There are two dimples in the bottom of each ammo can. Drill a 1/2" hole at each dimple. A smaller hole will get clogged. Depending on the system, we may have drilled these for you already.

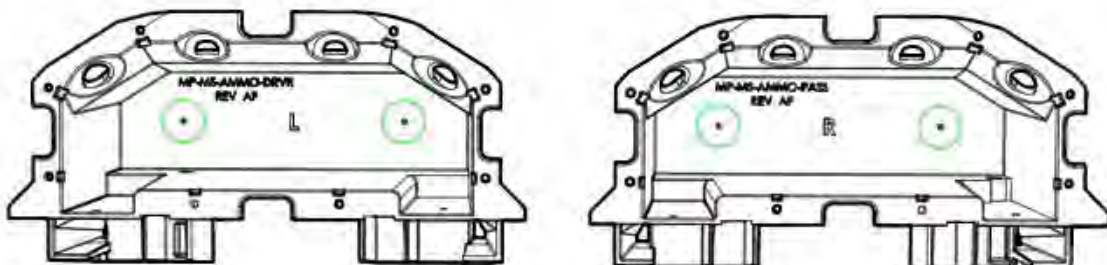



# Follow correct instructions for your bed length.

## PREP BED: SHIMS - MH1

- Mark the center of the bed.
- There are 4 wide and 2 narrow shims in your hardware kit.
- Referencing the drawing below, clean the surfaces where the shims will be installed. Isopropyl alcohol is recommended.
- Remove adhesive backing from shim and apply with firm pressure.

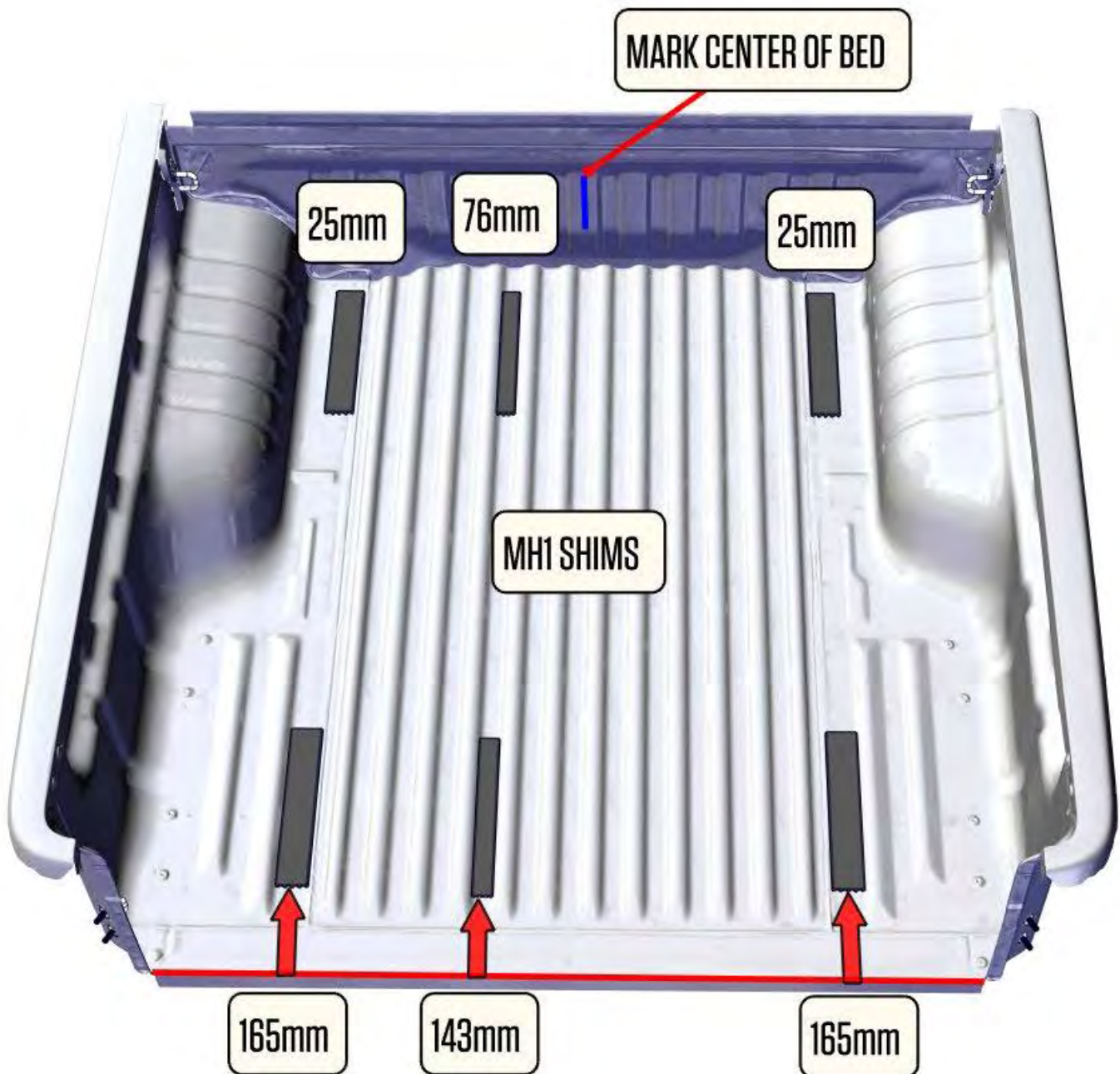



# Follow correct instructions for your bed length.

## PREP BED: SHIMS - MH2

- Mark the center of the bed.
- There are 4 wide and 2 narrow shims in your hardware kit.
- Referencing the drawing below, clean the surfaces where the shims will be installed. Isopropyl alcohol is recommended.
- Remove adhesive backing from shim and apply with firm pressure.

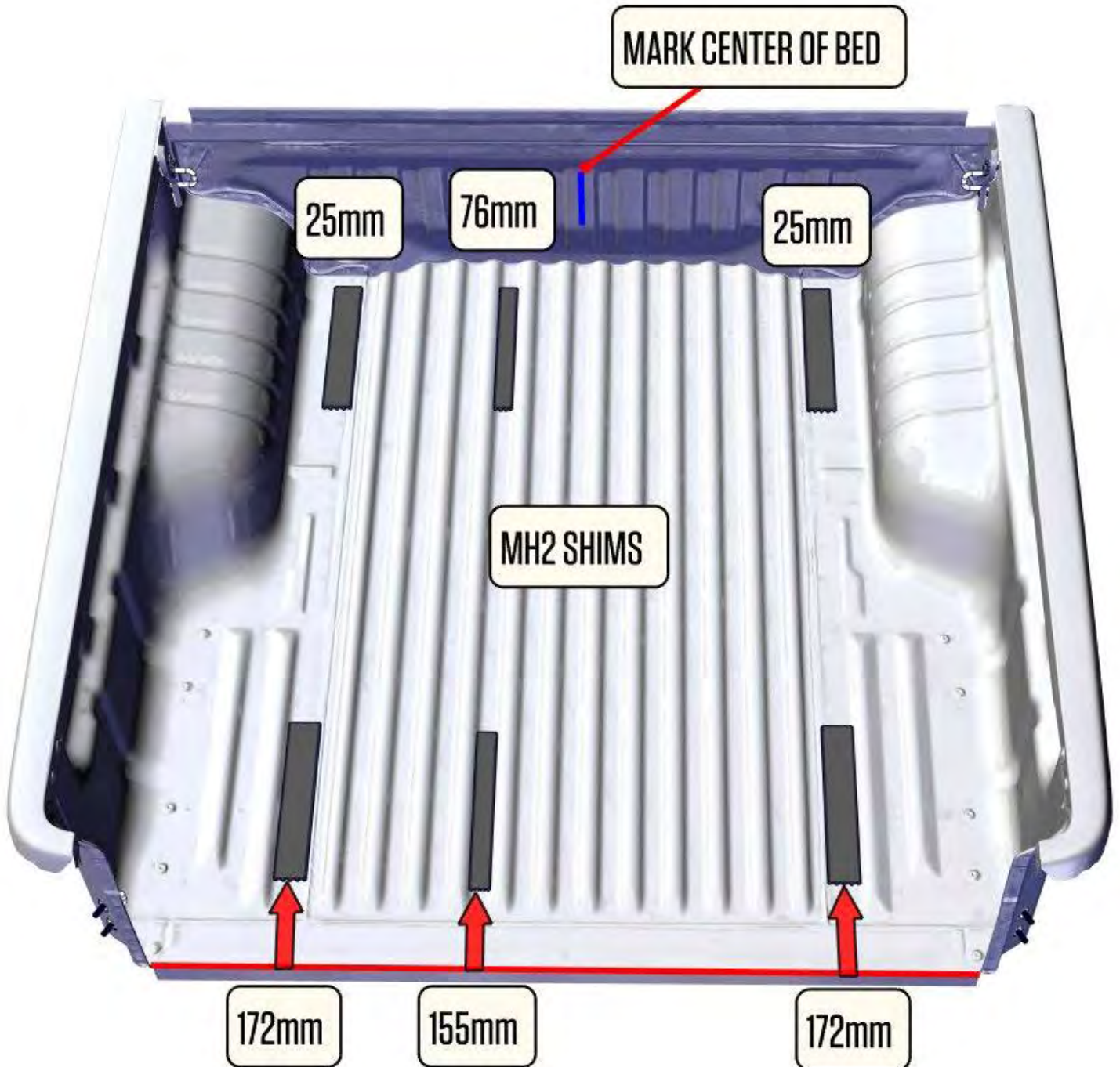

# ASSEMBLY: CENTER VERT + CABSIDE VERT

Grab your bag: **SL1, PREP MH1-MH2**

- **NOTE:** Perform the next few steps on a flat surface.
- Place hook on center vert over notch in cabside vert. **DETAIL A.**
- There are three types of bolts in the SL1 bag. Use the plain, stainless steel bolts for the steps on this page.
- Attach the center vert to the cabside vert with four plain bolts from the SL1 bag. Tighten just until snug. 3 Nm. **DETAIL B.**
- We included a 3/8" socket in the PREP MH1-MH2 bag.

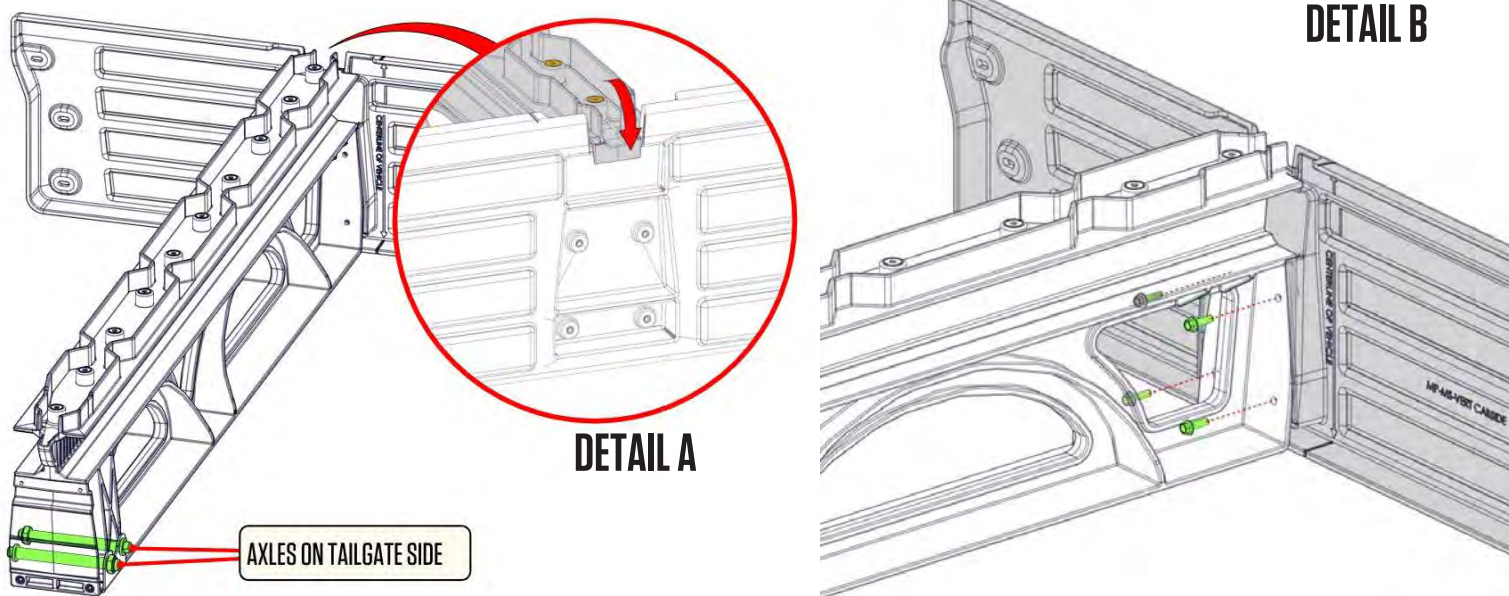

# ASSEMBLY: LOOSELY ATTACH STUDS (YUP)

Grab your bag: **SL1**

- **LOOSELY** attach the studs to the cabside vert with the plain stainless steel bolts.
- Leave all of these loose for now.

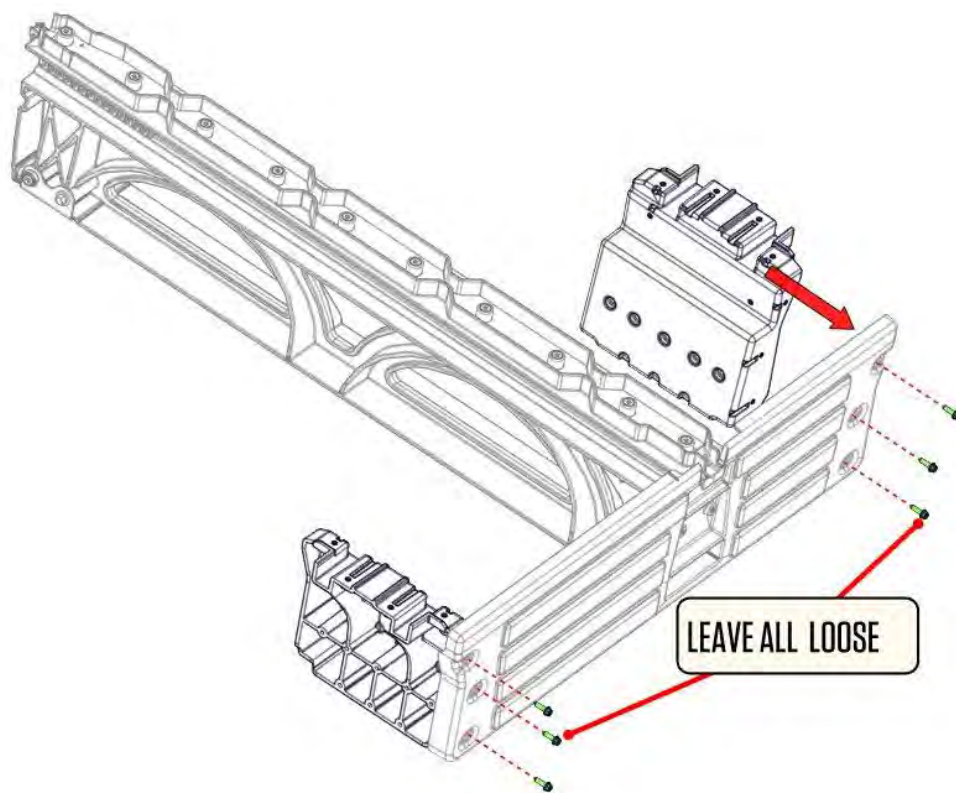

# ASSEMBLY: ALIGN STUDS AND PANELS

**NOTE:** The next two steps ensure the studs are properly located before tightening bolts. It's important. Don't skip it.

Grab your bag: **SL1**

- Place ammo cans to support tailgate end of deck panels.
- Place deck panels on center vert + stud + cabside vert assembly.
- Slide studs around L- R until deck panels are seated.
- Move ammo cans around to seat the panels onto the ammo cans.
- **DETAIL A:** There are three types of bolts in the SL1 bag -use the plain stainless bolts for all steps on this page.
- Loosely secure each panel to the cabside stud supports. Don't tighten these. **DETAIL A**
- Now you can securely tighten the bolts that hold the studs to the cabside vert. 3 Nm. **DETAIL B.**

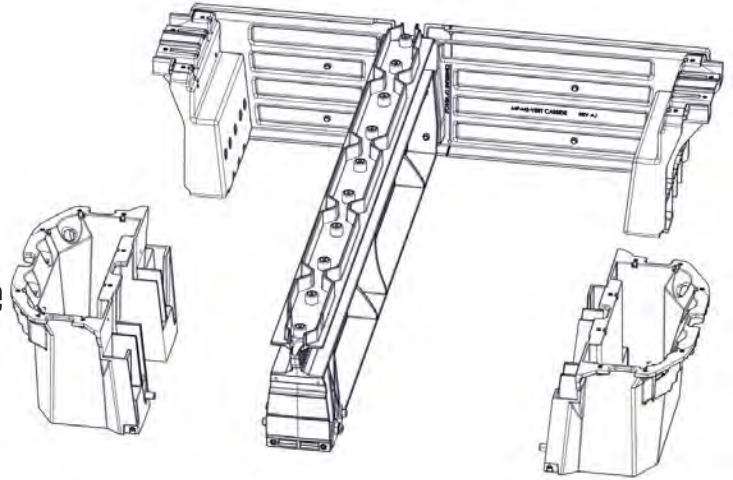

If you will be installing a CargoGlide onto the DECKED drawer system, now is the time to grab your CargoGlide instructions and prepare the panels - do not put the drawer system in your truck.

- Unbolt deck from studs (DETAIL A bolts), remove deck panels, save bolts, remove ammo cans and set aside for later assembly.

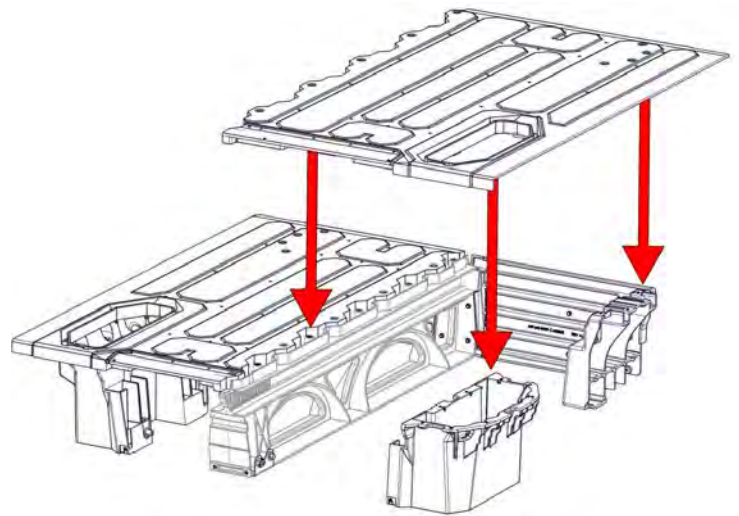
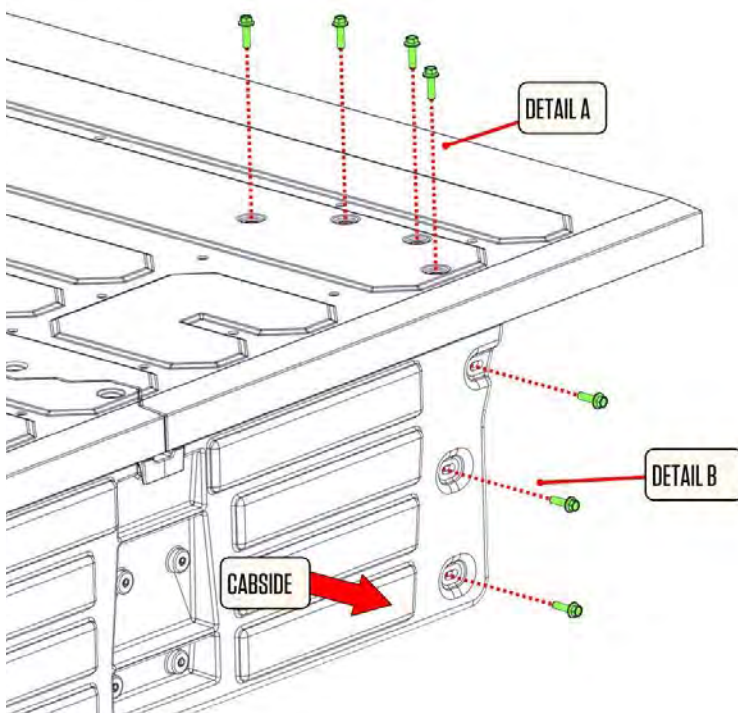

**HELPFUL TIP:** This step seems like a waste of time, but Dr. DECKED says it's important...don't skip out.

# PREP BED: MARK CABSIDE HOLES and ASSEMBLE JACK NUT TOOL

Grab your bag: **PREP MH1/MH2**

- Temporarily place cabside vert + center vert + stud assembly in truck bed.
- Make sure centerline arrow on cabside vert is aligned with your centerline mark (blue).
- Mark the truck bed via the pre-drilled holes in cabside vert.
- Remove assembly from truck bed.
- Drill four 11mm holes at marked locations using a drill stop set to 6mm.
- NOTE: To resist corrosion, seal the raw metal edges of the drilled holes with the self-etching primer included in the hardware kit. Allow to dry before proceeding.

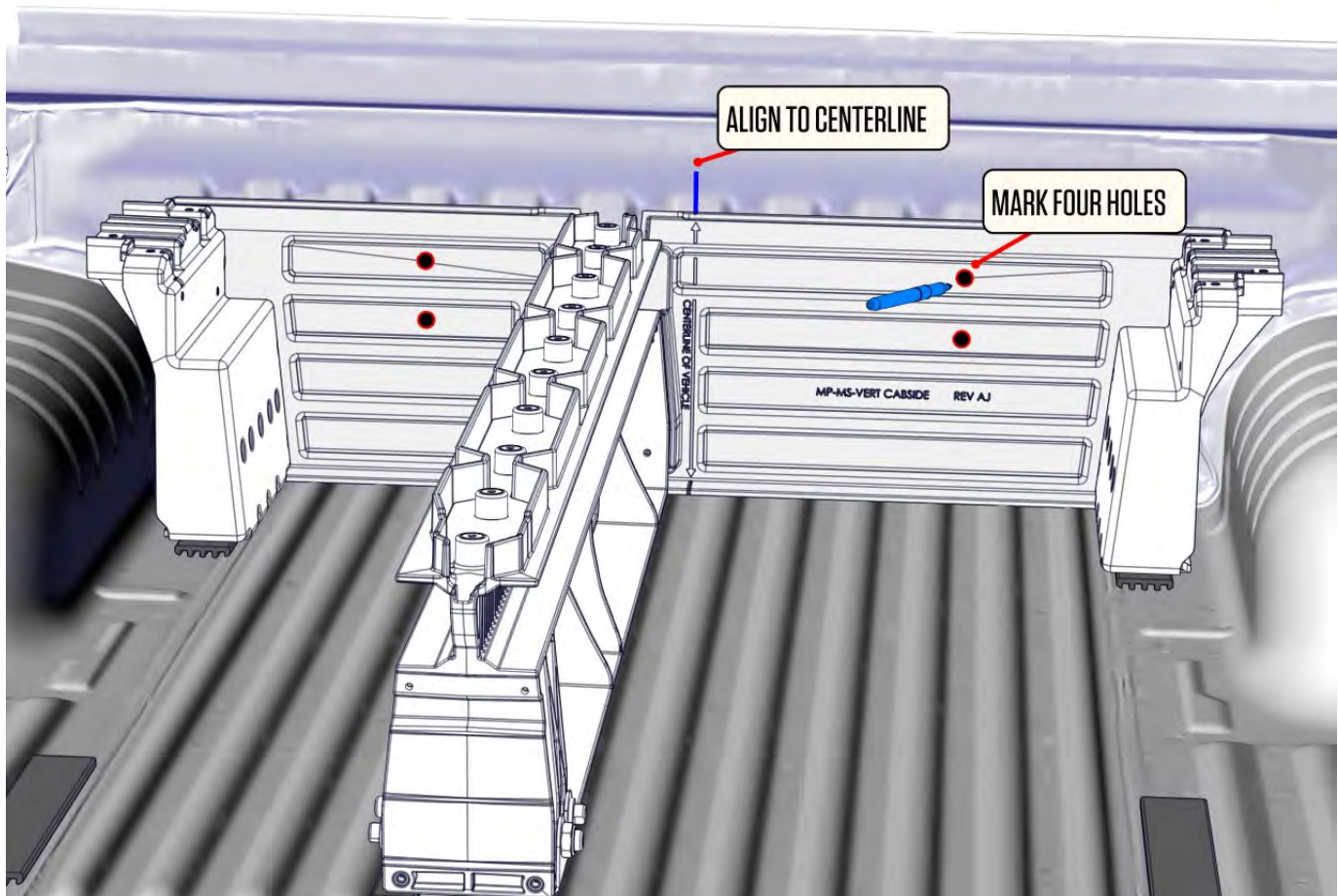

- Assemble jacknut tool with items from the PREP MH1/MH2 bag - install the washer onto the 2" bolt.
- Install the jacknut tool, narrow side first. Screw on the jacknut, wide side first. **DETAIL C.**

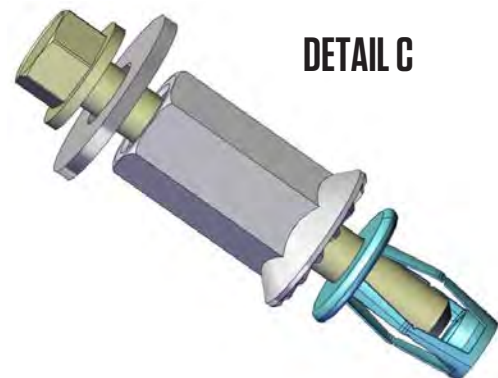



# INSTALL: INSTALL JACKNUTS and BASE ASSEMBLY

Grab your bag: **PREP MH1/MH2**

- Using the jacknut assembly, insert the jacknut end into one of the drilled holes.
- You may have to tap it in lightly with a hammer.
- Holding the jacknut tool with a 14mm wrench, use the 3/8" socket to screw the bolt and crimp the jacknut. 3 Nm.
- Do not overtighten.
- Remove bolt, washer and jacknut tool.
- Repeat for the other three holes.
- Save the jacknut tool for your tool box!

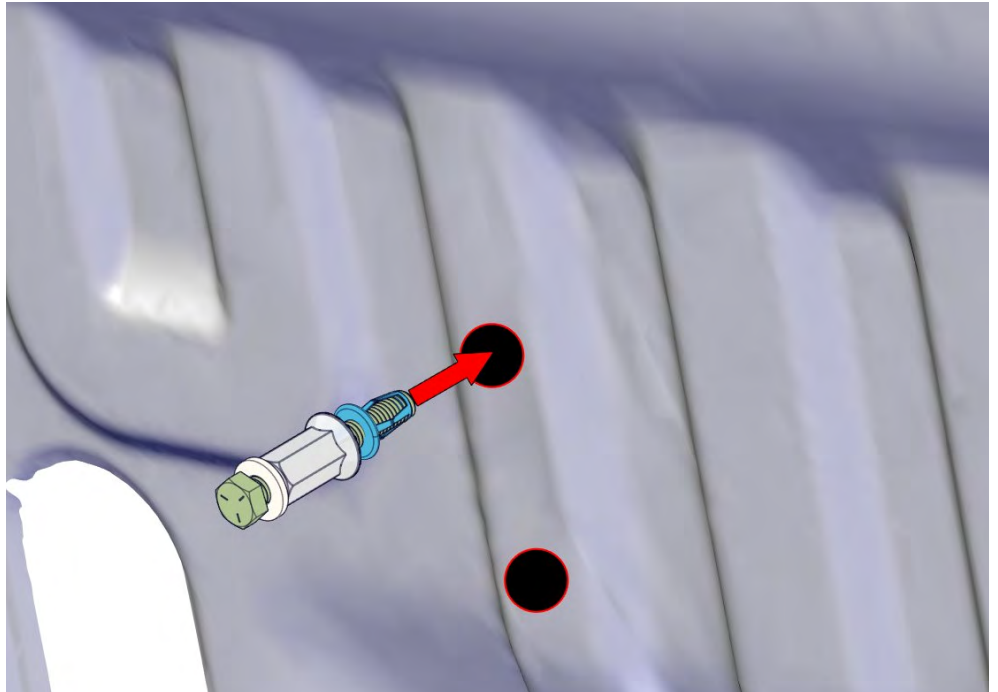

- Replace the base assembly in your truck.
- Install the assembly with four stainless steel bolts and washers as shown. Tighten until snug, 3Nm.

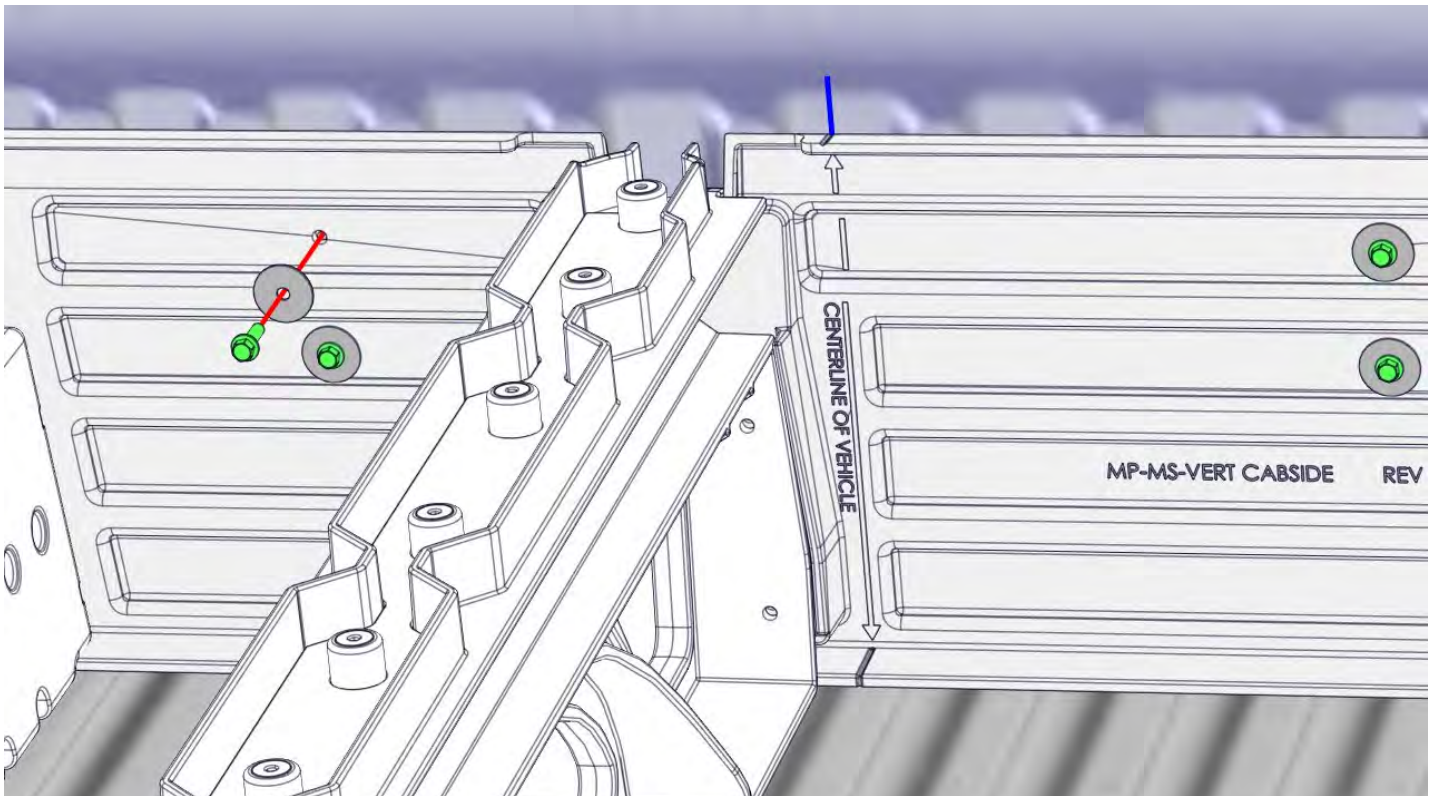

# INSTALL: C-CHANNELS

Grab your bag: **SL1, B2, N1**

**IMPORTANT:** The ammo can axles must be on the tailgate side of the assembly. The bolt heads must be on the inside of the C-channel.

- Loosely place the left side ammo can at tailgate corner of bed. The axle will be closest to you. There is an "L" on the inside of the can. The left can must be on the left side. Don't get this wrong.
- Place a C-channel on the ledge of the stud and ammo can with the end plate on the stud (cabside).
- Use two of the BLACK SL1 bolts to install the C-channel to the cabside stud. No nuts needed here.
- Tighten until snug. 3 Nm.
- Use two B2 bolts and two N1 nuts to LOOSELY install the C-channel to the ammo can. KEEP LOOSE.
- Repeat on the right side.

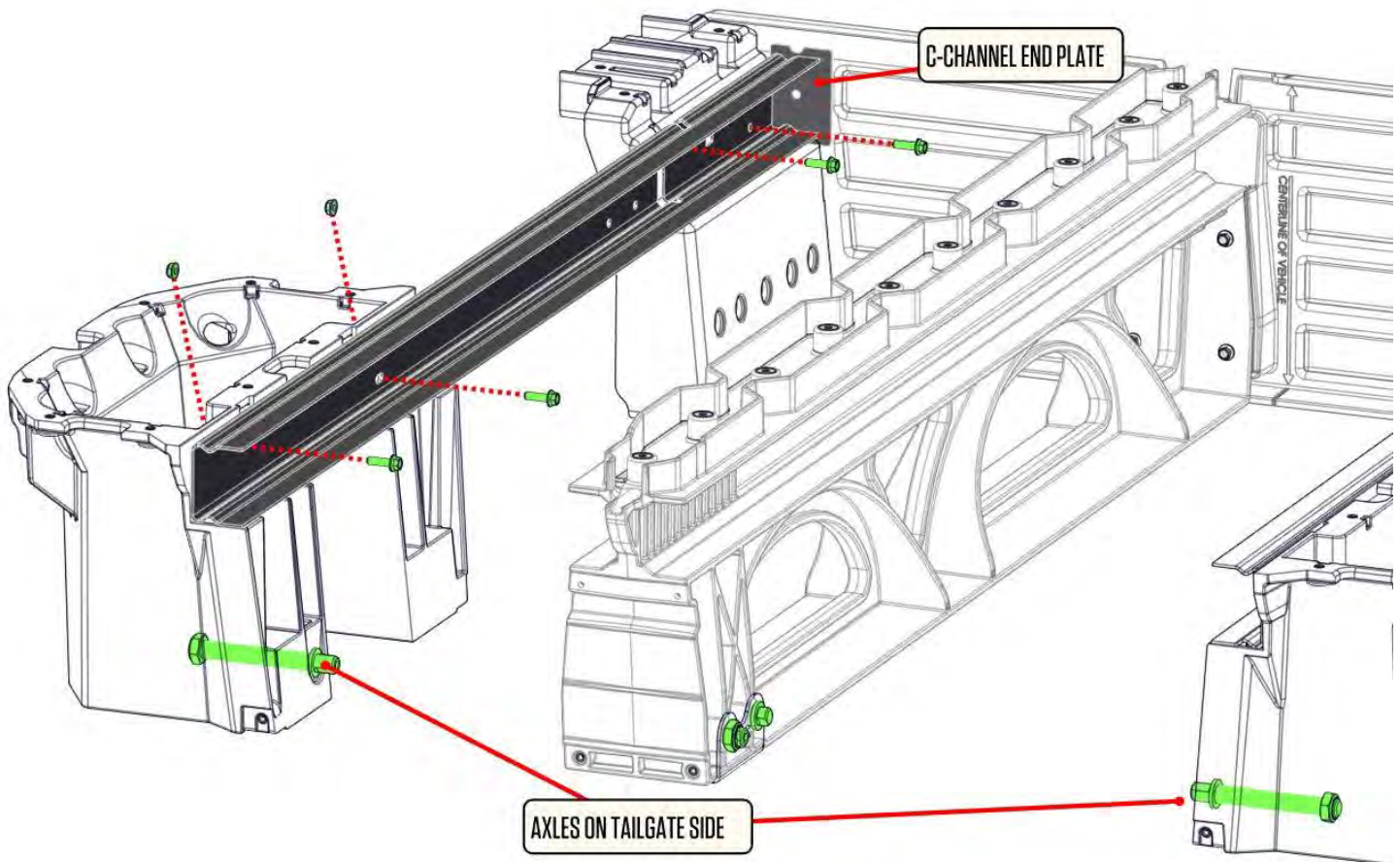

# INSTALL: DECK HALVES

*Grab your bag: SL1*

- Place the left deck panel on cabside stud, center vert and ammo can.
- Shift ammo can forward, rearward, L-R, as necessary to align with deck panel.
- Start all bolts with your fingers to avoid cross-threading.
- Use the plain stainless SL1 bolts to attach the deck panel to the center vert (blue lines). Tighten until snug. 3 Nm.
- Use the plain stainless SL1 bolts to attach the deck panel to the cabside stud (red lines). Tighten just until snug. 3 Nm
- Use the SL1 bolts with the blue Rimlex sealant applied under the bolt head to attach the deck panel to the ammo can (orange lines). Tighten until snug. 3 Nm.
- Now tighten the C-channel to ammo can bolts. Don't forget unless you like rattles.
- Repeat on the right side **(making sure you remember to securely tighten C-channel/ammo can nuts and bolts).**

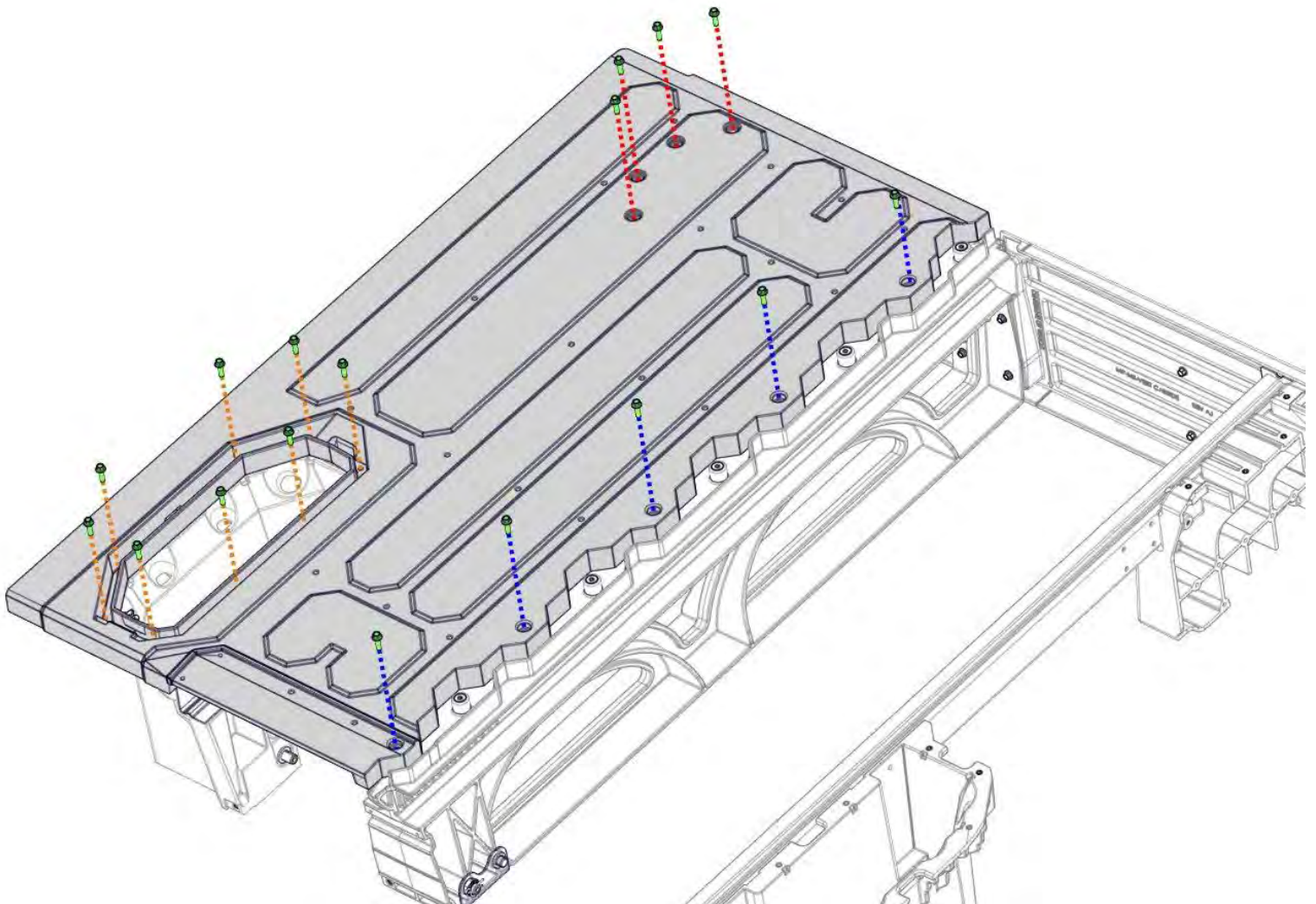

# DRAWERS: BRACKETS + WHEELS

Grab your bag: **DRAWER 1/DRAWER2/WHEELS**

- Each drawer has a left and a right wheel bracket. Place the brackets into the drawers as shown.
- Install two 3/4" bolts into the bottom two bracket holes. Secure with nuts but leave loose. **DETAIL A.**
- Install the 2" bolts through the back mounting hole where shown. Secure with a nut. 3 Nm. **DETAIL A.** Tighten above nuts until snug. 3 Nm.
- Use two 3/4" bolts to install the tube brace from the **DRAWER 3** bag. 3 Nm. **DETAIL B.**
- Install the wheels with the 7/32" hex wrench we included in the hardware kit. **DETAIL C.**

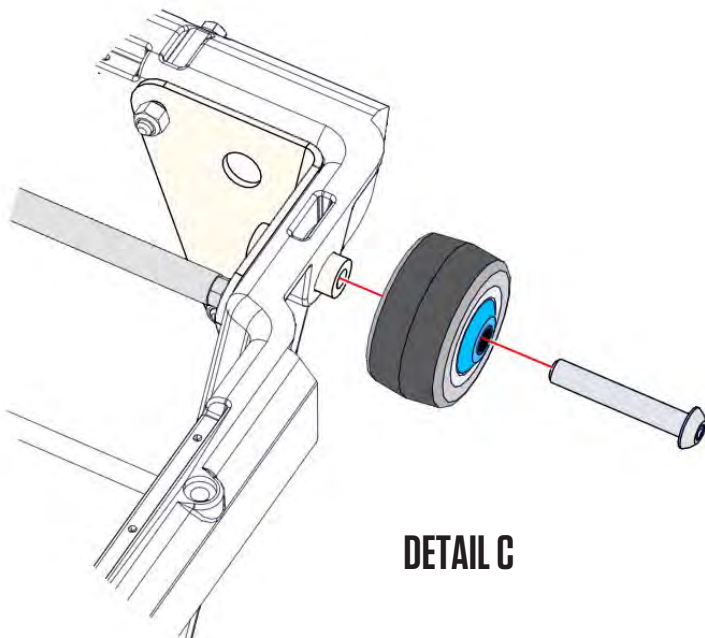
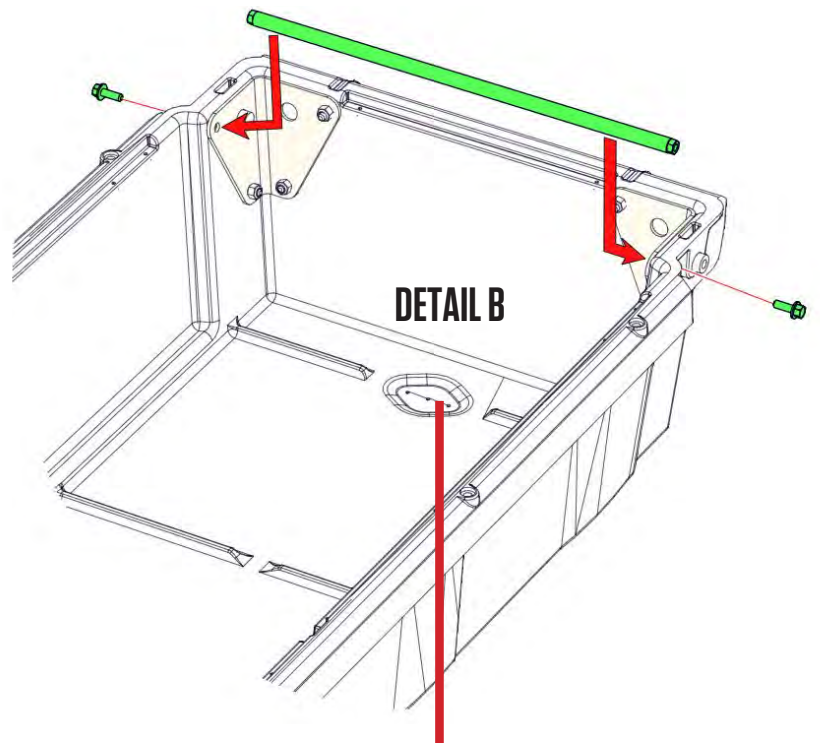
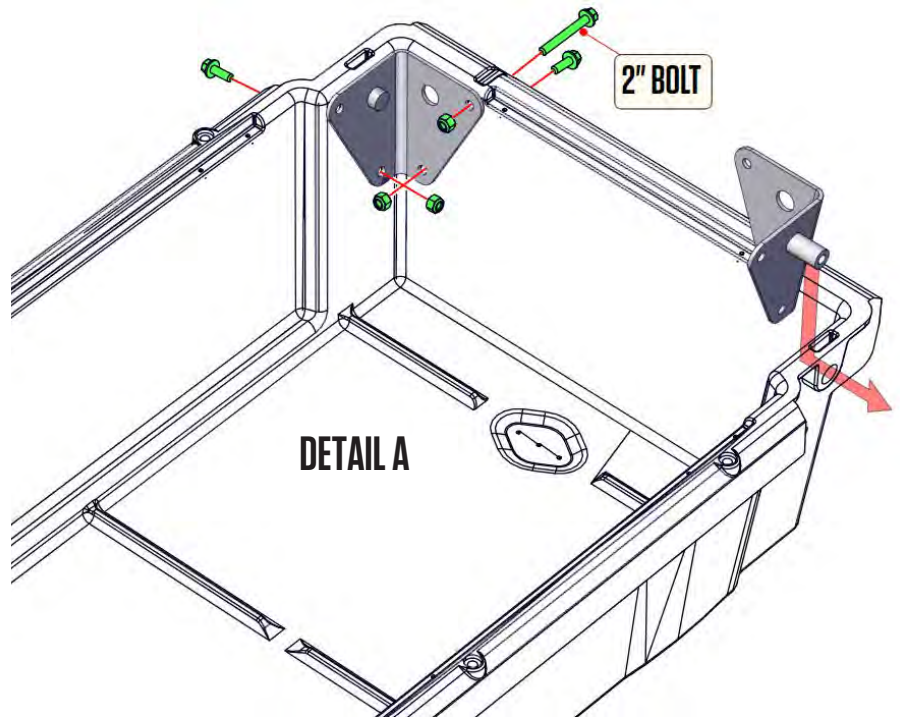

**HELPFUL TIP:** If you purchased drain plugs, install now (instructions are included with drain plugs).

# DRAWERS: WHEELS + WEATHERSTRIPS

Grab your bag: **WHEELS**

- Slide narrow drawer into driver side drawer cavity. **NOTE: It is easier to fully install the narrow drawer first.**
- **DETAIL A:** Install two tailgate wheels onto narrow drawer axles with a 7/32" hex wrench.
- Repeat with wide drawer.

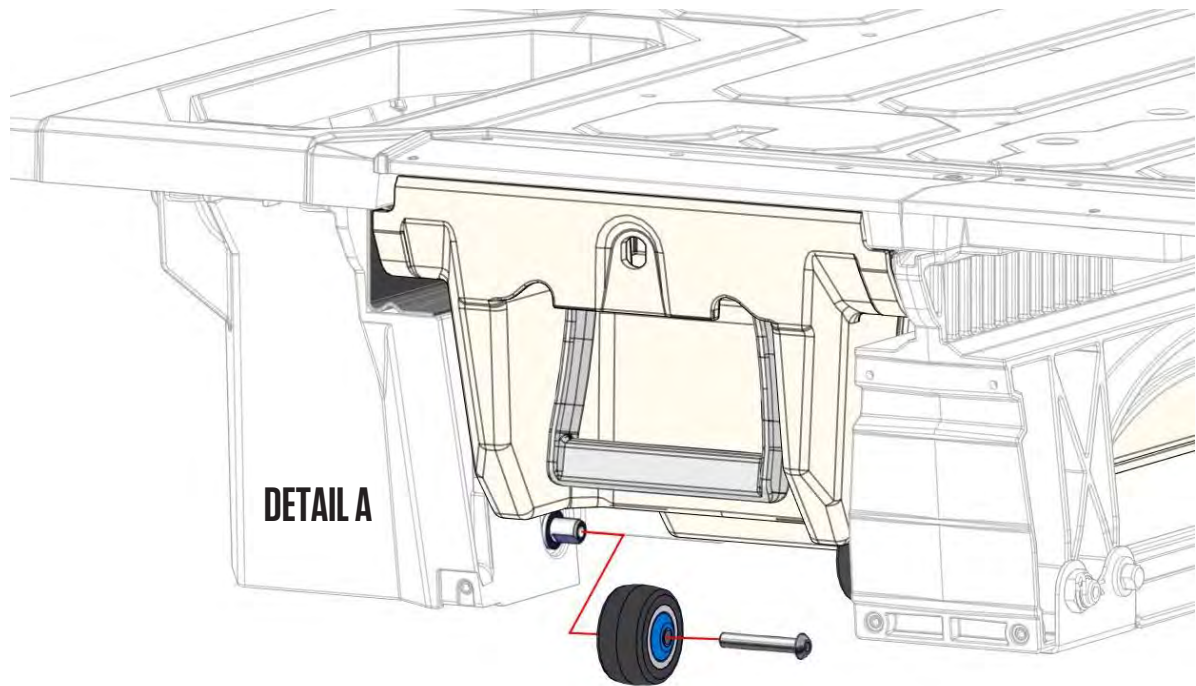

- Install weatherstrips on top of drawer edges WITH WIPER BLADE POINTING TOWARD DRIVER. **IMPORTANT: Facing the weatherstrip the wrong way will funnel water into drawer: BAD!**

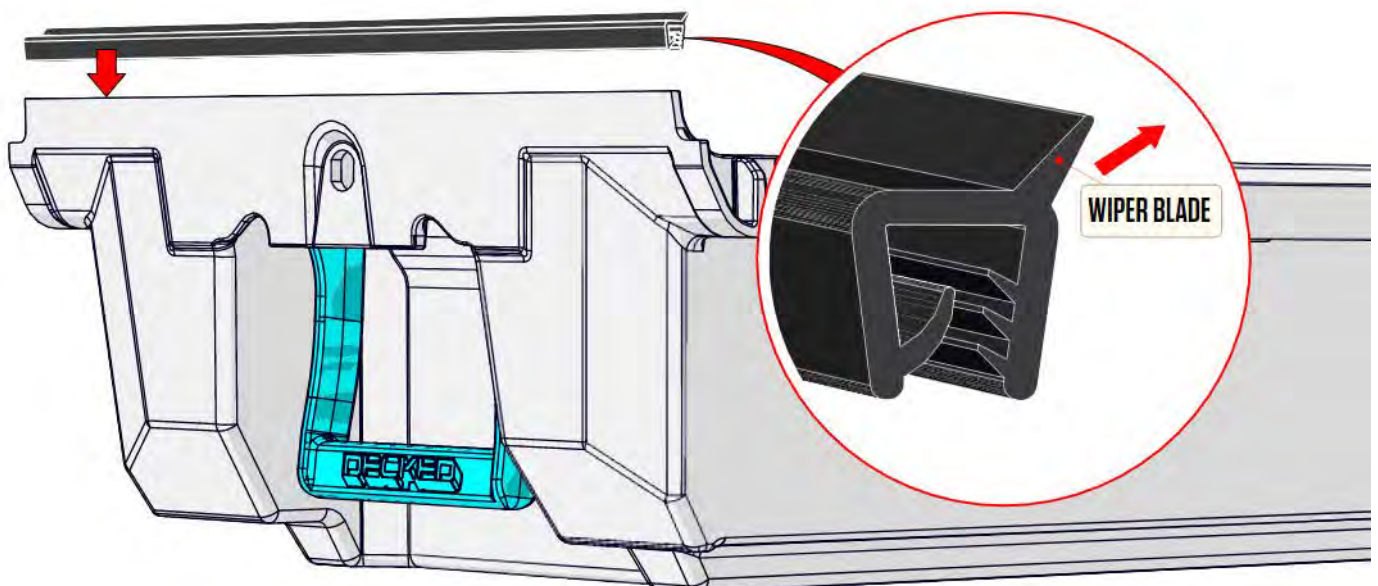

# THE FUN STUFF: TORSION BRACE + BOTTLE OPENER + RULER

Grab your bag: **SL1, FINAL MS**

- Slide torsion brace under center vert and tailgate ammo cans. The side without the holes slides UNDER the center vert and tailgate ammo cans.
- Place bottle opener on the outside of the torsion brace.
- Loosely install (start with your fingers to avoid cross-threading):
  - Two black 1/2" bolts through the upper holes in the bottle opener into the center vert - leave loose.
  - Two black SL1 bolts through the bottom bottle opener holes and torsion brace into the center vert inserts - leave loose.
  - Two black SL1 bolts through the end holes in torsion brace into the tailgate ammo can inserts - leave loose.
- Align bottle opener to edges of center vert and tighten the four bottle opener bolts just until snug.
- Tighten the torsion brace end bolts into tailgate ammo cans just until snug. 3 Nm.
- Install lock core plugs into the drawer lock holes or install locks if purchased. (Instructions included with locks)
- Align the ruler plate on the tailgate end of the panels. Use an 1/8" hex wrench to install the six ruler screws into the panel inserts - do not overtighten these.

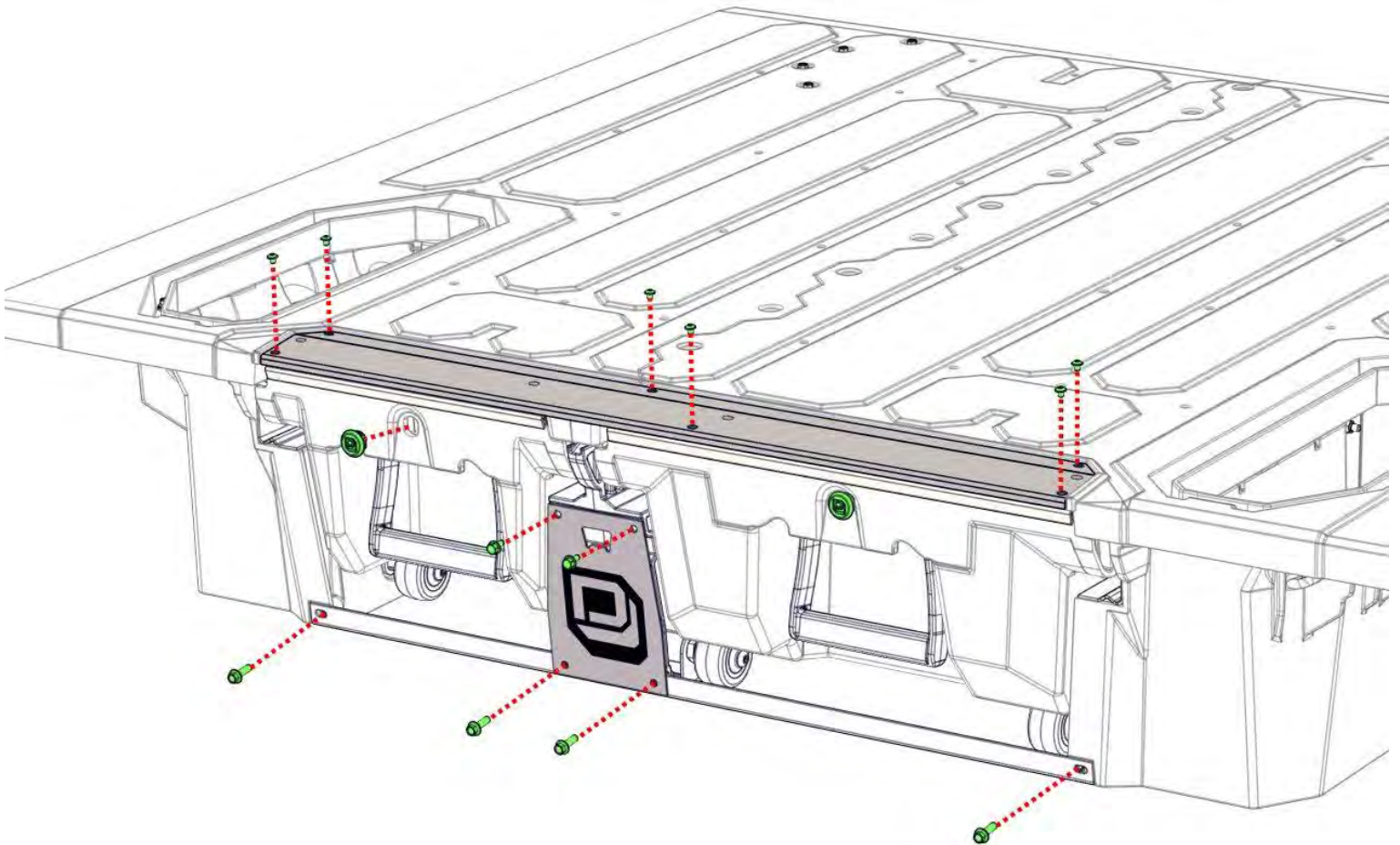

Grab your bag: JB, FINAL MS

## INSTALL: J-HOOKS

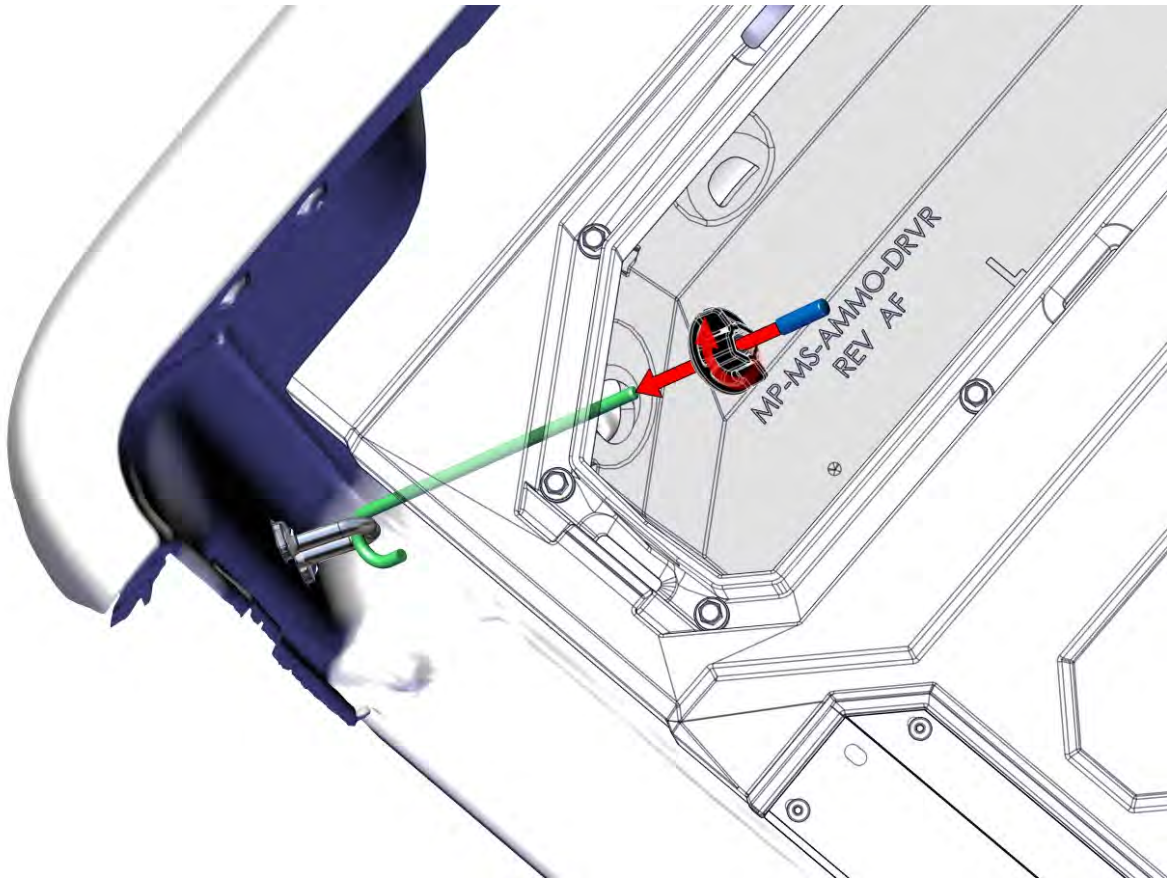

- Install J-hook onto tie down bracket and through the hole closest to the **tailgate** in ammo can.
- Make sure the hook opens towards the tailgate.
- Install winged-spherical nut-washer, round side down, onto J-hook and partially tighten using your fingers only. **IMPORTANT: Keep J-hook assembly loose.**
- Repeat other side.
- Tighten the J-hooks, but **DO NOT OVER TIGHTEN!** Make sure the gap between the side wall of the bed and the deck is equal on both sides.
- Install bolt thread protectors on J-hook ends.
- Install ammo can lids.

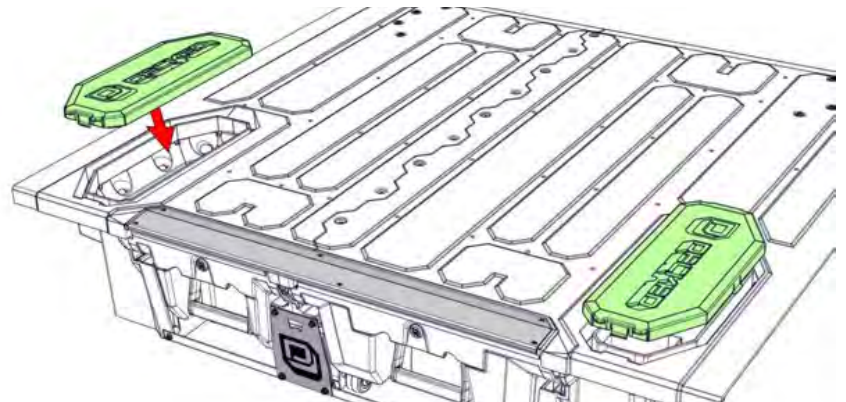

**IMPORTANT:** You did it! Get your favorite beverage ready to crack open in the bottle opener and make a toast to your truck. When finished, immediately post a photo of your significant other, child or canine (in no order of significance - please someone show us your pet alligator) appreciating your accomplishment. Add hashtag #DECKEDUSA | @DECKEDUSA.

# DECKED Products – Limited Lifetime Warranty

(Valid on DECKED Products purchased on or after 8/1/2021)

DECKED LLC, (the “Manufacturer”) warrants the original purchaser only that DECKED Truck and Van Products (The “DECKED” Product) will be free from defects in material and workmanship from the date of purchase and continuing for the expected lifetime of the DECKED Product. The DECKED Product must be registered by the original purchaser with DECKED, LLC via its website at, [www.decked.com/register](http://www.decked.com/register), and a copy of the original sales receipt must be supplied to the Manufacturer at the time a warranty claim is made. This warranty terminates if the original purchaser transfers the DECKED Product to any other person or vehicle.

## WHAT IS COVERED

All DECKED Products identified above on or after August 1, 2021

**DECKED's Limited Lifetime Warranty applies to US and Canadian customers only. International shipments are covered by DECKED's 3 Year Limited Warranty.**

## WHAT WE WILL DO TO CORRECT PROBLEMS

Subject to the limitations and exclusions described in this limited warranty, the Manufacturer will remedy defects in workmanship or materials by providing one of the following remedies at its option and without charge to the original purchaser for parts: (a) repairing the defective portion of the DECKED Product or (b) replacing the entire DECKED Product. In addition, the Manufacturer may elect at its option not to repair or replace the DECKED Product, but rather issue to the original purchaser a refund equal to the purchase price paid for the DECKED Product or a credit to be used towards the purchase of a new DECKED Product.

## WHAT IS NOT COVERED

This limited warranty expressly excludes:

- Damage or defects caused by normal wear and tear, cosmetic rust, scratches, accidents, unlawful vehicle operation, installation in a non-supported vehicle or installed in a vehicle which does not match the DECKED Product's SKU-intended fitment or use, or modification of the product, or any types of repair of a DECKED Product other than those authorized or provided by the Manufacturer.
- Damage or defects resulting from conditions beyond the Manufacturer's control and specifications including, but not limited to modification, misuse, overloading, or failure to assemble, install or use the DECKED Product in accordance with the Manufacturer's written instructions or guidelines included with the DECKED Product or separately made available to the original purchaser.
- Damage to the contents of the DECKED Product or vehicle.
- TO THE EXTENT PERMITTED BY LAW, IN NO EVENT SHALL THE MANUFACTURER BE LIABLE FOR ANY INCIDENTAL, SPECIAL, INDIRECT, OR CONSEQUENTIAL DAMAGES, INCLUDING ECONOMIC LOSS, WHETHER RESULTING FROM NONPERFORMANCE, USE, MISUSE, OR INABILITY TO USE THE DECKED PRODUCT OR THE MANUFACTURER'S NEGLIGENCE.

## NO OTHER EXPRESS WARRANTY APPLIES

This Limited Lifetime Warranty is the sole and exclusive warranty for DECKED Products. No employee, agent, dealer, or other person is authorized to alter this warranty or make any other warranty on behalf of DECKED LLC.

## NOTIFICATION PROCEDURES

If the DECKED Product does not conform with the terms of this limited warranty, the original purchaser must promptly notify the Manufacturer in writing upon discovery of the nonconformity. In order to receive remedies under this limited warranty, a warranty claim must have been registered with DECKED LLC by the original purchaser, must describe the nature of the products nonconformity, include a copy of the original sales receipt, invoice, or other proof of purchase and be accompanied with photos or video. Repairs or modifications made to the DECKED Product by other than the Manufacturer or its authorized agent will nullify this limited warranty. Coverage under this limited warranty is conditioned at all times upon the owner's compliance with these required registration, notification, and repair procedures.

Product registration may be performed at: <https://decked.com/register>

Warranty claims must include reciprocal contact information and may be made via certified mail or email to:

**DECKED** Warranty and Claims

Contact info:

**DECKED LLC**

PO Box 885

Ketchum, ID 83340

[warranty@decked.com](mailto:warranty@decked.com)

208-806-0251

DECKED.COM | #DECKEDUSA | @DECKEDUSA

