

METHOD #: 420.2 (Issued 1974)

TITLE: Phenolics (Colorimetric, Automated 4-AAP With Distillation)

ANALYTE: Phenolics

INSTRUMENTATION: Autoanalyzer

STORET No. 32730

1.0 Scope and Application

- 1.1 This method is applicable to the analysis of drinking, surface and saline waters, domestic and industrial wastes.
- 1.2 The method is capable of measuring phenolic materials from 2 to 500 $\mu\text{g/L}$ in the aqueous phase using phenol as a standard. The working ranges are 2 to 200 $\mu\text{g/L}$ and 10 to 500 $\mu\text{g/L}$.

2.0 Summary of Method

- 2.1 This automated method is based on the distillation of phenol and subsequent reaction of the distillate with alkaline ferricyanide and 4-aminoantipyrine to form a red complex which is measured at 505 or 520 nm. The same manifold is used with the AAI or AAI.

3.0 Sample Handling and Preservation

- 3.1 Biological degradation is inhibited by the addition of 1 g/L of copper sulfate to the sample and acidification to a pH of less than 4 with phosphoric acid. The sample should be kept at 4°C and analyzed within 24 hours after collection.

4.0 Interference

- 4.1 Interferences from sulfur compounds are eliminated by acidifying the sample to a pH of less than 4.0 with H_3PO_4 and aerating briefly by stirring and adding CuSO_4 .
- 4.2 Oxidizing agents such as chlorine, detected by the liberation of iodine upon acidification in the presence of potassium iodide, are removed immediately after sampling by the addition of an excess of ferrous ammonium sulfate (6.5). If chlorine is not removed, the phenolic compounds may be partially oxidized and the results may be low.
- 4.3 Background contamination from plastic tubing and sample containers is eliminated by filling the wash receptacle by siphon (using Kel-F tubing) and using glass tubes for the samples and standards.

5.0 Apparatus

- 5.1 Technicon AutoAnalyzer (I or II)
 - 5.1.1 Sampler equipped with continuous mixer.
 - 5.1.2 Manifold.
 - 5.1.3 Proportioning pump II or III.
 - 5.1.4 Heating bath with distillation coil.
 - 5.1.5 Distillation head.
 - 5.1.6 Colorimeter equipped with a 50 mm flow cell and 505 or 520 nm filter.
 - 5.1.7 Recorder.

6.0 Reagents

- 6.1 Distillation reagent: Add 100 mL of conc. phosphoric acid (85% H_3PO_4) to 800 mL of distilled water, cool and dilute to 1 liter.
- 6.2 Buffered potassium ferricyanide: Dissolve 2.0 g potassium ferricyanide, 3.1 g boric acid and 3.75 g potassium chloride in 800 mL of distilled water. Adjust to pH of 10.3 with 1 N sodium hydroxide (6.3) and dilute to 1 liter. Add 0.5 mL of Brij-35. Prepare fresh weekly.
- 6.3 Sodium hydroxide (1N): Dissolve 40 g NaOH in 500 mL of distilled water, cool and dilute to 1 liter.
- 6.4 4-Aminoantipyrine: Dissolve 0.65 g of 4-aminoantipyrine in 800 mL of distilled water and dilute to 1 liter. Prepare fresh each day.
- 6.5 Ferrous ammonium sulfate: Dissolve 1.1 g ferrous ammonium sulfate in 500 mL distilled water containing 1 mL H_2SO_4 and dilute to 1 liter with freshly boiled and cooled distilled water.
- 6.6 Stock phenol: Dissolve 1.00 g phenol in 500 mL of distilled water and dilute to 1000 mL. Add 1 g CuSO_4 and 0.5 mL conc. H_3PO_4 as preservative. 1.0 mL = 1.0 mg phenol.
- 6.7 Standard phenol solution A: Dilute 10.0 mL of stock phenol solution (6.6) to 1000 mL. 1.0 mL = 0.01 mg phenol.
- 6.8 Standard phenol solution B: Dilute 100.0 mL of standard phenol solution A (6.7) to 1000 mL with distilled water. 1.0 mL = 0.001 mg phenol.
- 6.9 Standard solution C: Dilute 100.0 mL of standard phenol solution B (6.8) to 1000 mL with distilled water. 1.0 mL = 0.0001 mg phenol.
- 6.10 Using standard solution A, B or C prepare the following standards in 100 mL volumetric flasks. Each standard should be preserved by adding 0.1 g CuSO_4 and 2 drops of conc. H_3PO_4 to 100.0 mL.

mL of Standard Solution	Conc. $\mu\text{g/L}$
<u>Solution C</u>	
1.0	1.0
2.0	2.0
3.0	3.0
5.0	5.0
<u>Solution B</u>	
1.0	10.0
2.0	20.0
5.0	50.0
10.0	100.0
<u>Solution A</u>	
2	200
3	300
4	500

7.0 Procedure

- 7.1 Set up the manifold as shown in Figures 1 or 2.
- 7.2 Fill the wash receptacle by siphon. Use Kel-F tubing with a fast flow (1 liter/hr).
- 7.3 Allow colorimeter and recorder to warm up for 30 minutes. Run a aseline with all reagents, feeding distilled water through the sample ine. Use polyethylene tubing for sample line. When new tubing is sed, about 2 hours may be required to obtain a stable baseline. This wo hour time period may be necessary to remove the residual phenol rom the tubing.
- 7.4 Place appropriate phenol standards in sampler in order of decreasing oncentration. Complete loading of sampler tray with unknown samples, sing glass tubes.
NOTE 1: If samples have not been preserved as instructed in (3.1), dd 0.1 g CuSO_4 and 2 drops of conc. H_3PQ to 100 mL of sample.
- 7.5 Switch sample line from distilled water to sampler and begin analysis.

8.0 Calculation

- 8.1 Prepare standard curve by plotting peak heights of standards against oncentration values. Compute concentration of samples by comparing ample peak heights with standards.

9.0 Precision and Accuracy

- 9.1 In a single laboratory (EMSL), using sewage samples at concentrations f 3.8, 15, 43 and 89 $\mu\text{g/L}$, the standard deviations were ± 0.5 , $\pm .6$, ± 0.6 and ± 1.0 $\mu\text{g/L}$, respectively. At concentrations of 73, 46, 299 and 447 $\mu\text{g/L}$, the standard deviations were ± 1.0 , ± 1.8 , ± 4.2 and ± 5.3 $\mu\text{g/L}$, respectively.
- 9.2 In a single laboratory (EMSL), using sewage samples at concentrations f 5.3 and 82 $\mu\text{g/L}$, the recoveries were 78% and 98%. At concentrations of 168 and

489 $\mu\text{g/L}$, the recoveries were 97% and 98%, respectively.

Bibliography

1. Technicon AutoAnalyzer II Methodology, Industrial Method No. 127-71W, AAI.
2. Standard Methods for the Examination of Water and Wastewater, 14th Edition, p 574, Method 510 (1975).
3. Gales, M.E. and Booth, R.L., "Automated 4 AAP Phenolic Method", AWWA 68, 540 (1976).

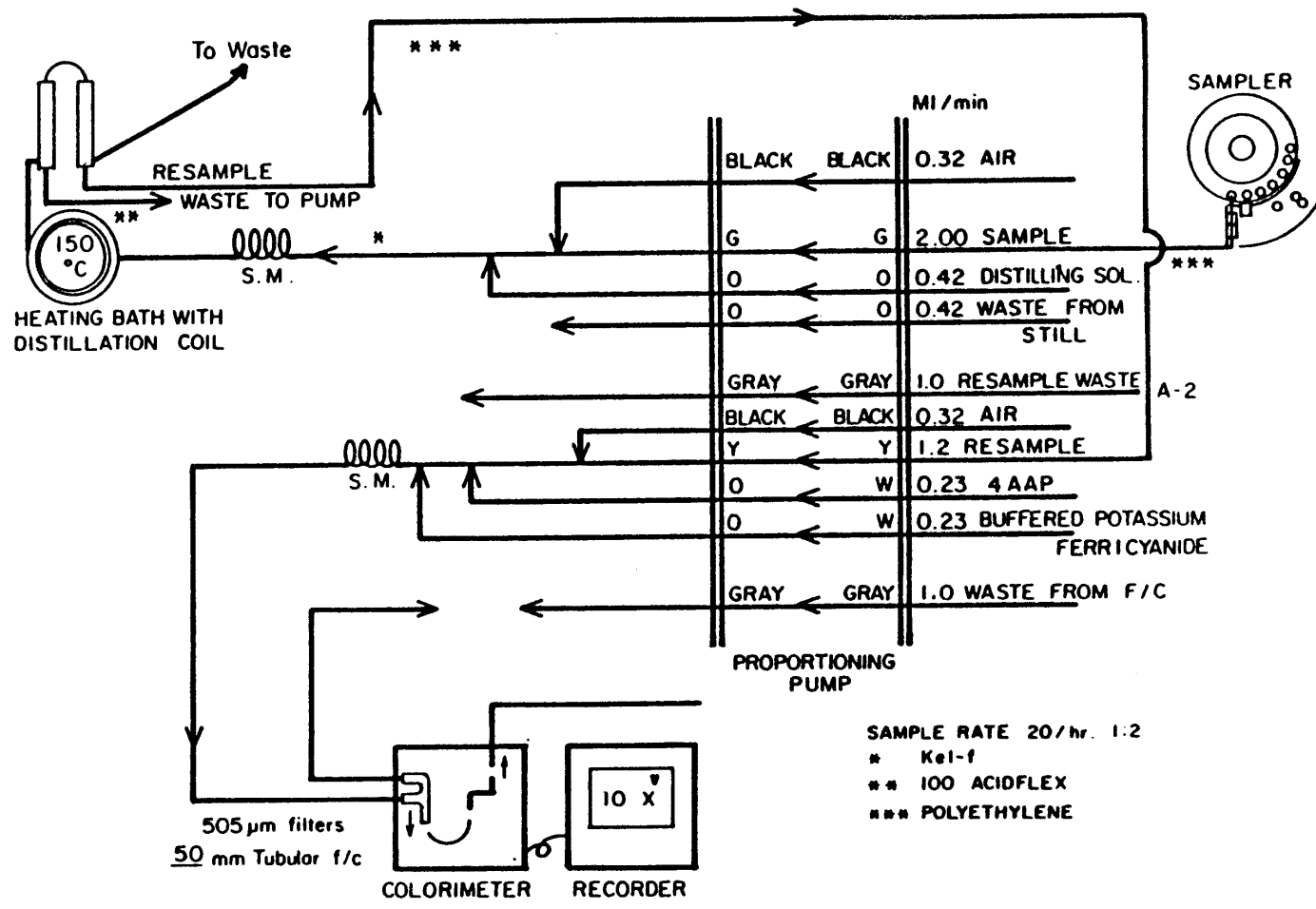

FIGURE 1. PHENOL AUTO ANALYZER I

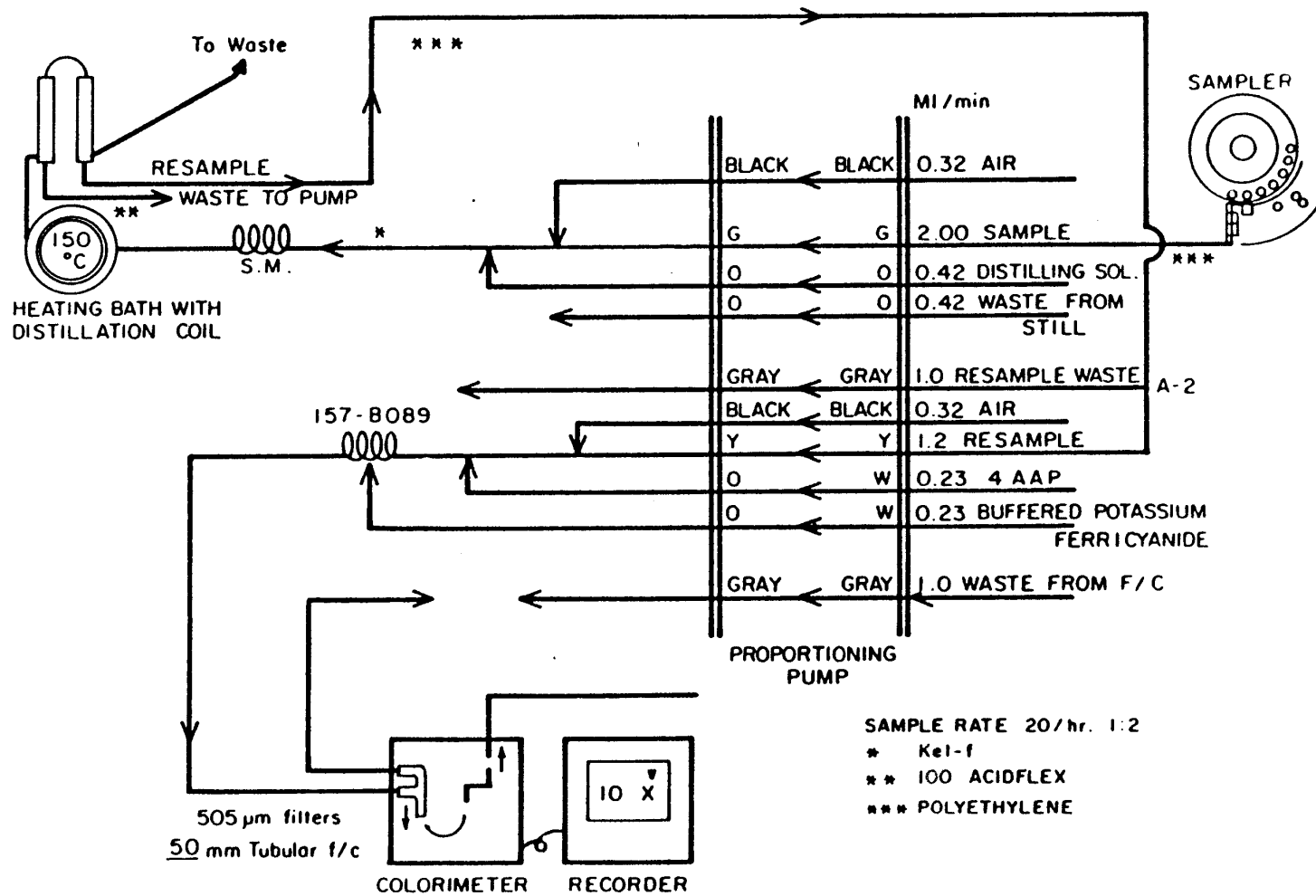

FIGURE 2. PHENOL AUTO ANALYZER II