



Installation Instructions Van:
VNFD13TRAN55

FORD TRANSIT

130" WHEELBASE

2014-CURRENT

TOOLS REQUIRED

- #2 Phillip screwdriver
- 3/8" socket
- 7/16" deep socket
- 7/32" Allen wrench
- 1/8" Allen wrench
- Wire cutters

Watch short installation videos at www.decked.com/video | Register your system at www.decked.com/warranty

FOLLOW US:      @DECKEDUSA | #DECKEDUSA

VERSION 5

DECKED.COM | 208.806.0251

RC376

CONTENTS

DECKED carton

- LEFT/DRIVER DECK HALF - 1
- RIGHT/PASSENGER DECK HALF - 1
- CENTER VERT - 1
- DRAWER - 2
- FRONT AMMO CAN - 2
- REAR AMMO CAN - 2
- AMMO CAN LID - 4
- AMMO CAN WINDOW - 2
- C-CHANNEL - 2
- RULER - 1
- HARDWARE BOX - 1
- SIDEBOARDS - 2
- BOTTLE OPENER - 1
- TORSION BRACE - 1

Hardware box - unbagged components

(inside DECKED carton):

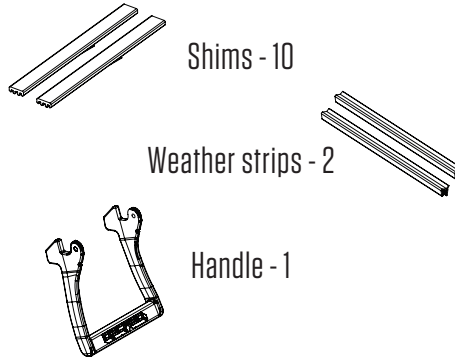

HARDWARE box - bagged components

- C-CHANNEL - 1
- BOLT 1FS (B1) - 1
- CS AMMO CANS - 1
- J7 - 2
- J8 - 2
- DRAWER 1 - 1
- DRAWER 3 - 1
- HANDLE - 1
- WHEELS - 1
- PREP-EXTRA - 1
- PREP TBO - 1
- WASHERS - 1
- SIDEBOARDS - 1

ASSEMBLY OVERVIEW

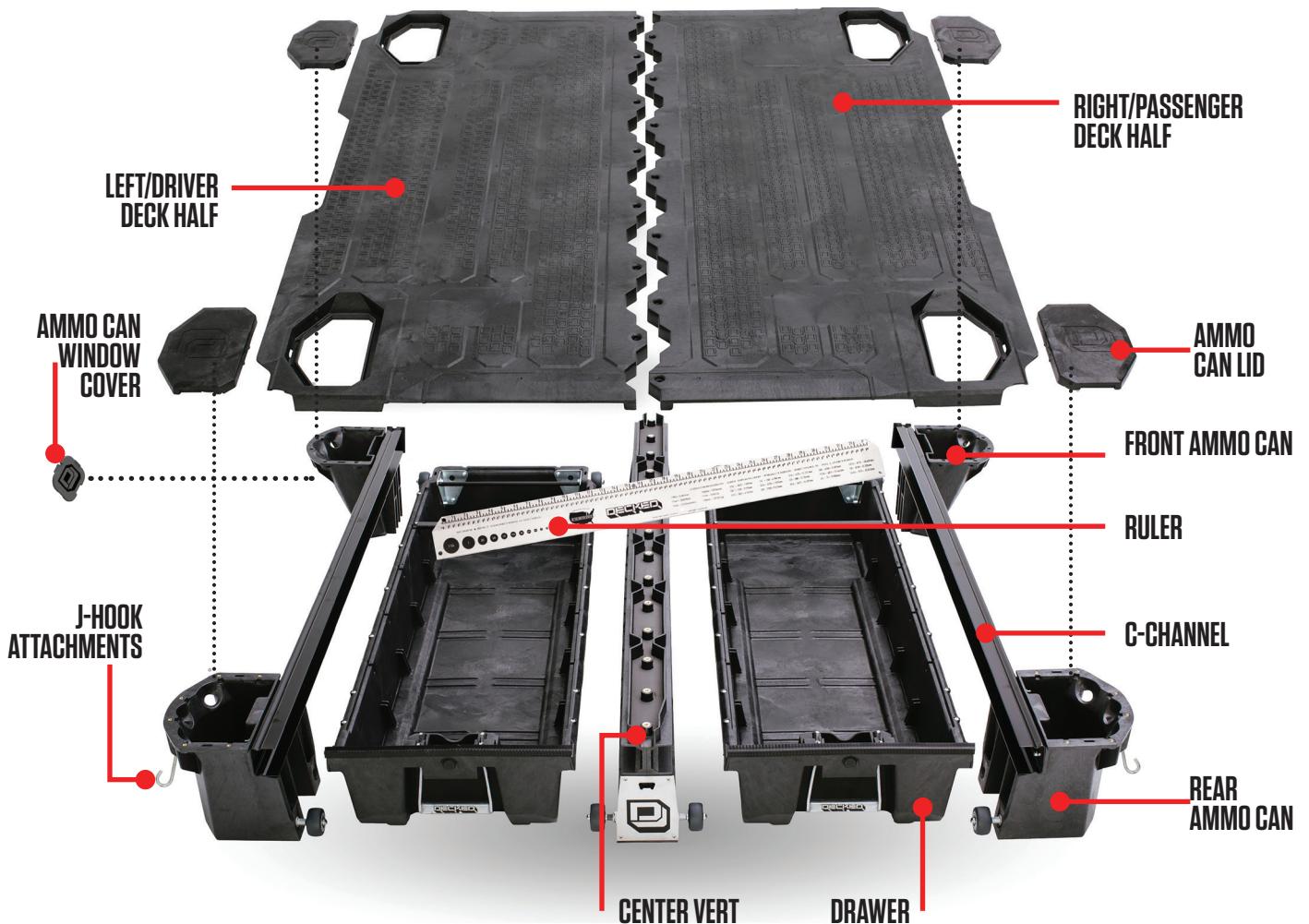

▼ HEY! TORQUE BOY: READ BEFORE YOU INSTALL DECKED ▼

1. **DECKED MUST** be installed in conjunction with a bulkhead wall and/or adequate structural framework to prevent injury as a result of a traffic accident.
2. **DON'T** go rogue on us, read the instructions.
3. **DON'T** over tighten bolts, get em' hand-tight.
4. **DON'T** use power tools.
5. **IF** you don't follow directions and **DO** use power tools:
1). Set clutch at a very low setting. 2). If you blow it, see NOTE.*
6. **DON'T** over tighten J-hooks during installation. Make 'em good and snug enough to keep the system from moving in the bed.
7. **USE** fingers to start all bolts to avoid cross-threading.
8. **REAR** ammo cans have wide bottoms; **FRONT** ammo cans have narrow bottoms.
9. **YOU** will need a buddy to help with exactly two steps.

NOTE* Two extra threaded inserts are included in **BAG PREP-EXTRA**. That's all you get.

The inserts will replace any stripped inserts in the rear ammo cans, but **NOT THE CENTER VERT**, so hand tighten until snug only! You can also screw the inserts back in if dislocated. There is a straight screwdriver slot on the underside of the insert.

You will have extra washers. You're welcome.

Prevent embarrassing, expletive-filled language, watch our detailed installation video or give us a call. We're happy to help!

208.806.0251 | DECKED.COM/INSTALLVIDEO



WARNING!

This product **MUST BE INSTALLED** in conjunction with a **bulkhead wall**, and/or **adequate structural framework** to prevent injury as a result of a traffic accident.

MADE IN THE USA

PREP VAN: INSTALL SHIMS

There are 10 shims provided:

- 1) If your vehicle is equipped with a rubber floor mat in the cargo area, you will need to remove the screws securing the plastic trim pieces at the base of the rear door and side door openings, and remove and set aside the plastic trim pieces. **If no mat is installed, skip to STEP 3 on this page.**
 - 2) At the rear door opening, lift the floor mat and fold it forward so it is clear of the floor area where the shims will be placed.
 - 3) Using the information in the respective circular detail views on the next page:
 - a) Clean the surfaces where the shims will be located. (Isopropyl alcohol is recommended).
 - b) Remove the layer of tape on the bottom of the shim to expose the adhesive surface.
 - c) Place the shim and apply with pressure.
- NOTE: STEPS A and C are to be repeated on the passenger side.**
- 4) When all shims are placed, roll the rubber mat back to cover the floor.
 - 5) Reinstall the plastic side and rear door trim pieces and secure with screws.

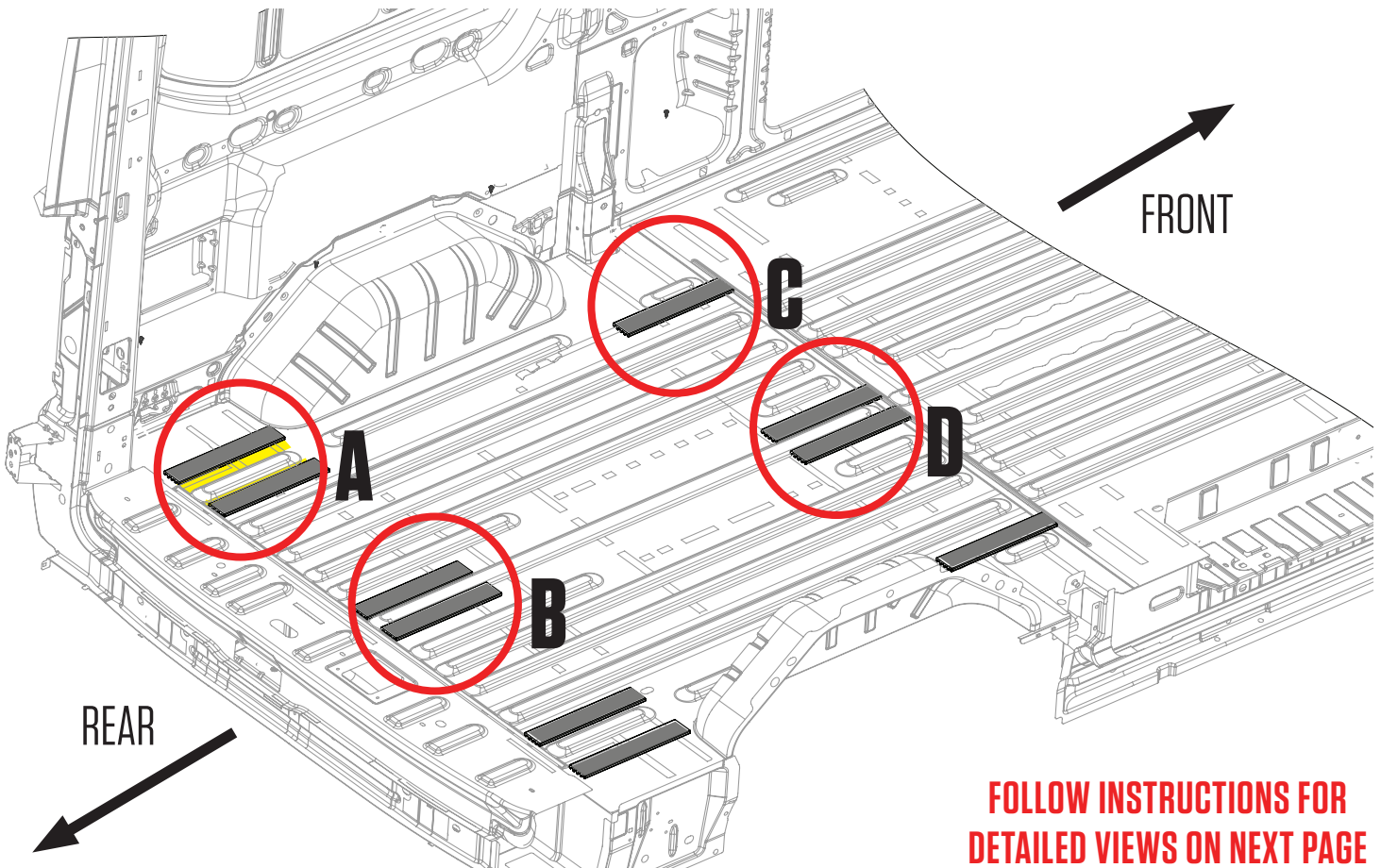

**FOLLOW INSTRUCTIONS FOR
DETAILED VIEWS ON NEXT PAGE**

PREP VAN: INSTALL SHIMS DETAIL

DETAIL A

Align rear of shims adjacent to transverse bead in floor (blue line). Repeat on passenger side.

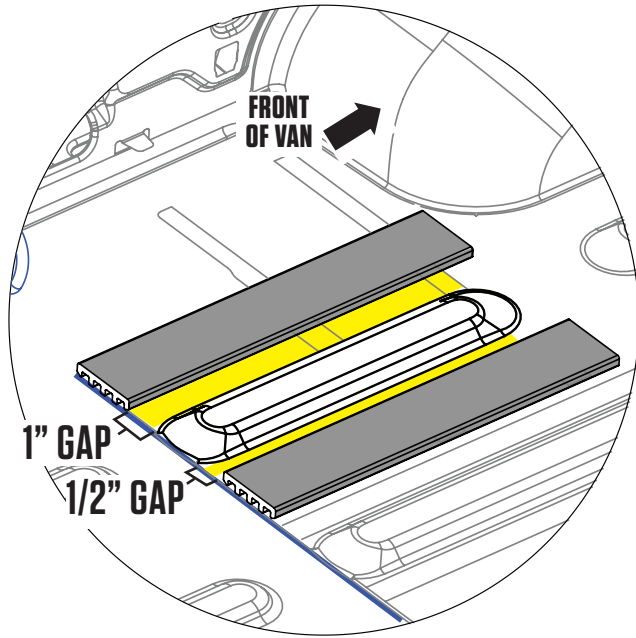

DETAIL C

Align front of shim adjacent to transverse bead in floor (blue line). Repeat on passenger side.

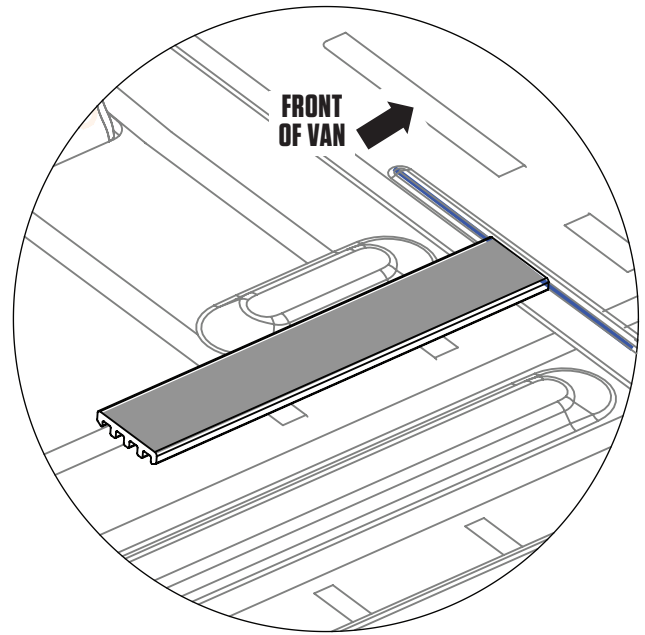

DETAIL B

Align rear of shims adjacent to transverse bead in floor (blue line).

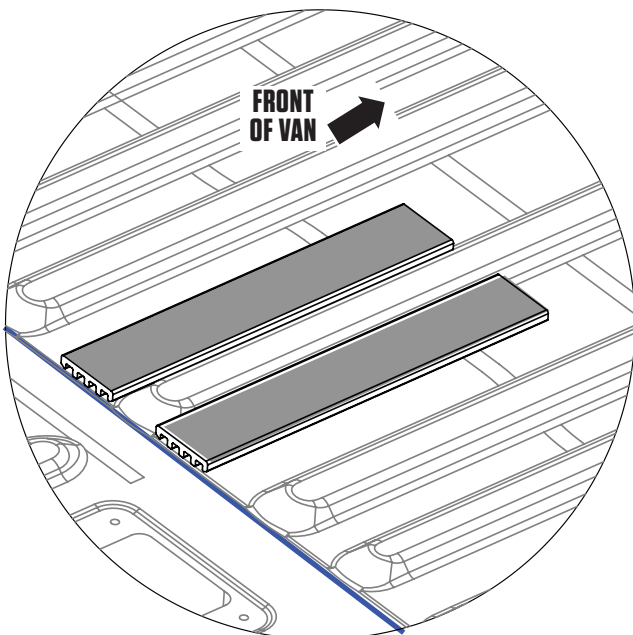

DETAIL D

Align front of shim adjacent to transverse bead in floor (blue line).

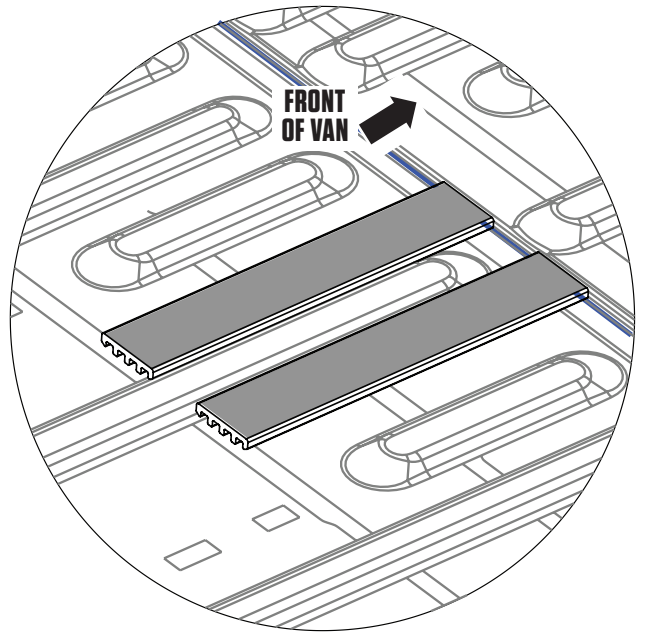

ASSEMBLY: DRIVER'S SIDE DECK

- There are three pre-installed gaskets – one on the center vert, one on each underside of the decks where they rest on the center vert. Do yours look weird? (They should be flat.) See them here: [DECKED.COM/GASKETS](https://www.decked.com/gaskets)
- Place C-channel on the **inside** ledges of a front ammo can and a rear ammo can.
- The end of the C-channel with the endplate must rest on the front ammo can.
- Verify that the rear ammo can's axle is closest to the rear of the van; if not, grab the other rear ammo can.

- Install nylon washers onto all bolts in **BAG C-CHANNEL, WASHERS**.
- Loosely bolt C-channel to the two ammo cans. Make sure the bolt head is in the C-channel, not inside the ammo can; **BAG C-CHANNEL**. Don't tighten yet.



- Line up the driver's side deck (sticker or mark on end of deck panel indicates LEFT/DRIVER) on top of the C-channel/ammo can assembly and the center vert bosses.

Hey Sparky: Rear end of the center vert has an axle installed; the center vert axle and ammo can axles must be on the rear end (not front end) of the assembly.

- Use **WASHERS** bag to install nylon & rubber washers on all **CS AMMO CAN** bolts. Install the same washers on 12 **B1** bolts...
- Use the above bolts to bolt the deck to the ammo cans; **BAG B1** for the rear ammo can, **BAG CS AMMO CAN** for the front ammo can.
- **Now tighten the loose bolts connecting the ammo cans to the C-channel.**
- Bolt the deck to the center vert; **BAG B1** (no washers). **If you must use power tools, use with caution! Set drill clutch to LIGHT.**



RECOMMENDED TORQUE: Bolts in labeled bags **C-CHANNEL, CS AMMO CAN** and **B1** - 27 in.-lb.

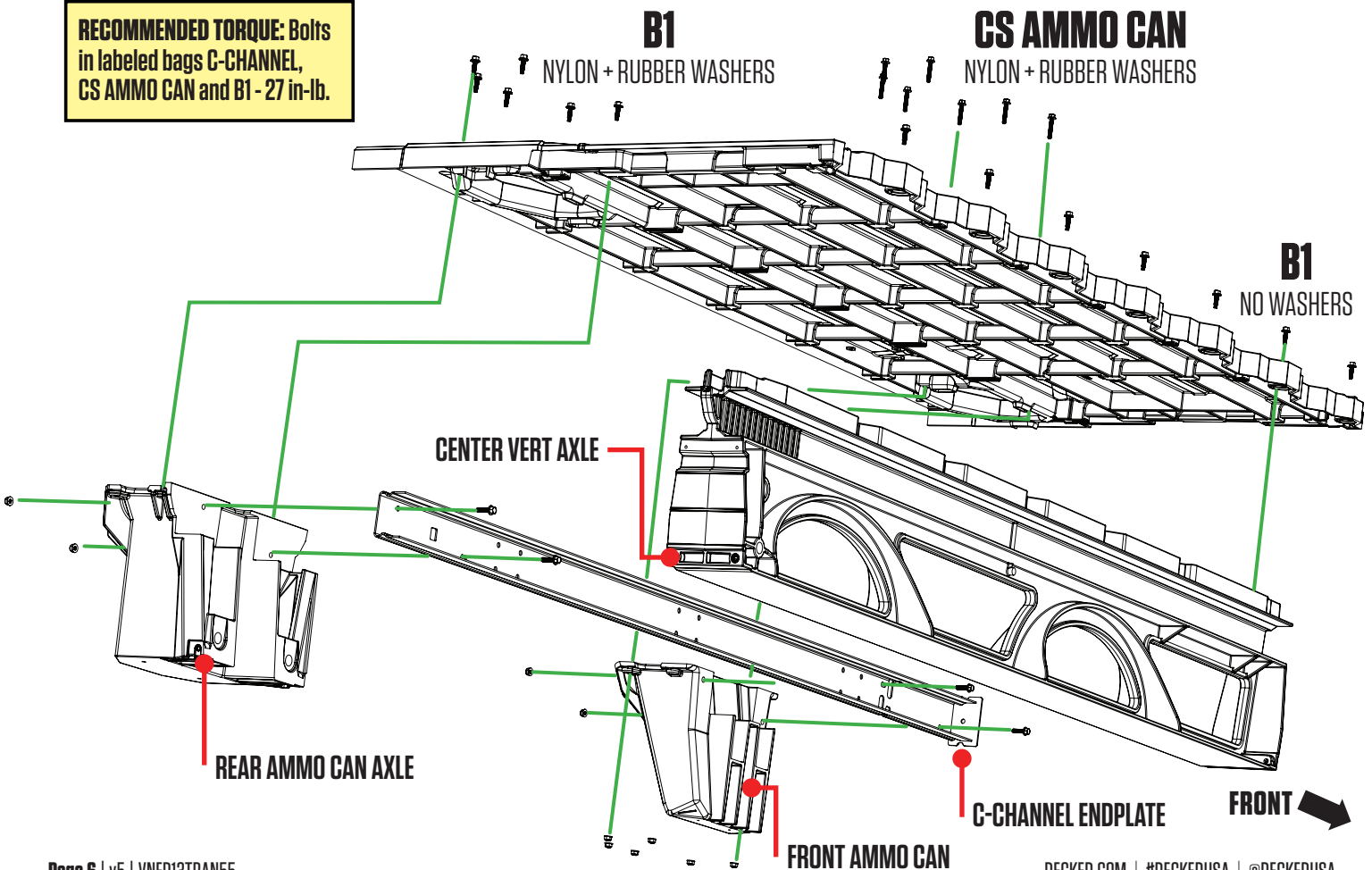

ASSEMBLY: PASSENGER'S SIDE DECK

- Using the assembly just built as a support, assemble the passenger side.
- Place C-channel on the **inside** ledges of a front ammo can and a rear ammo can.
- The C-channel endplate must rest on the front ammo can.
- You should have the correct rear ammo can for this step. The axle will be on the rear side of the system.
If not, swap the rear ammo cans now.
- Loosely bolt C-channel to the two ammo cans. Make sure the bolt head is in the C-channel, not inside the ammo can; **BAG C-CHANNEL** (with nylon washers). Deja vu, **don't** tighten yet.
- Line up the passenger's side deck (sticker or mark on end of deck panel indicates RIGHT/PASSENGER) on top of the C-channel/ammo can assembly.
- Bolt the deck to the ammo cans; **BAG B1** (with nylon and rubber washers) for the rear ammo can, **BAG CS AMMO CAN** (with nylon and rubber washers) for the front ammo can.
- **DO NOT bolt passenger deck to center vert. Do not pass GO! Do not collect \$200...**
- **Now tighten the loose bolts connecting the ammo cans to the C-channel.**
- Grab your buddy to help you lift the driver side assembly into the driver side of the van. Lift the passenger side assembly into the passenger side of the van and seat the passenger side deck on the upstanding, cylindrical vert bosses.
- Bolt the passenger side deck half to the center vert; **BAG B1** (no washers). Make sure all bolts connecting the deck to the center vert are snug.
Remember our warning about power tools?

RECOMMENDED TORQUE: Bolts in labeled bags C-CHANNEL, CS AMMO CAN and B1 - 27 in-lb.

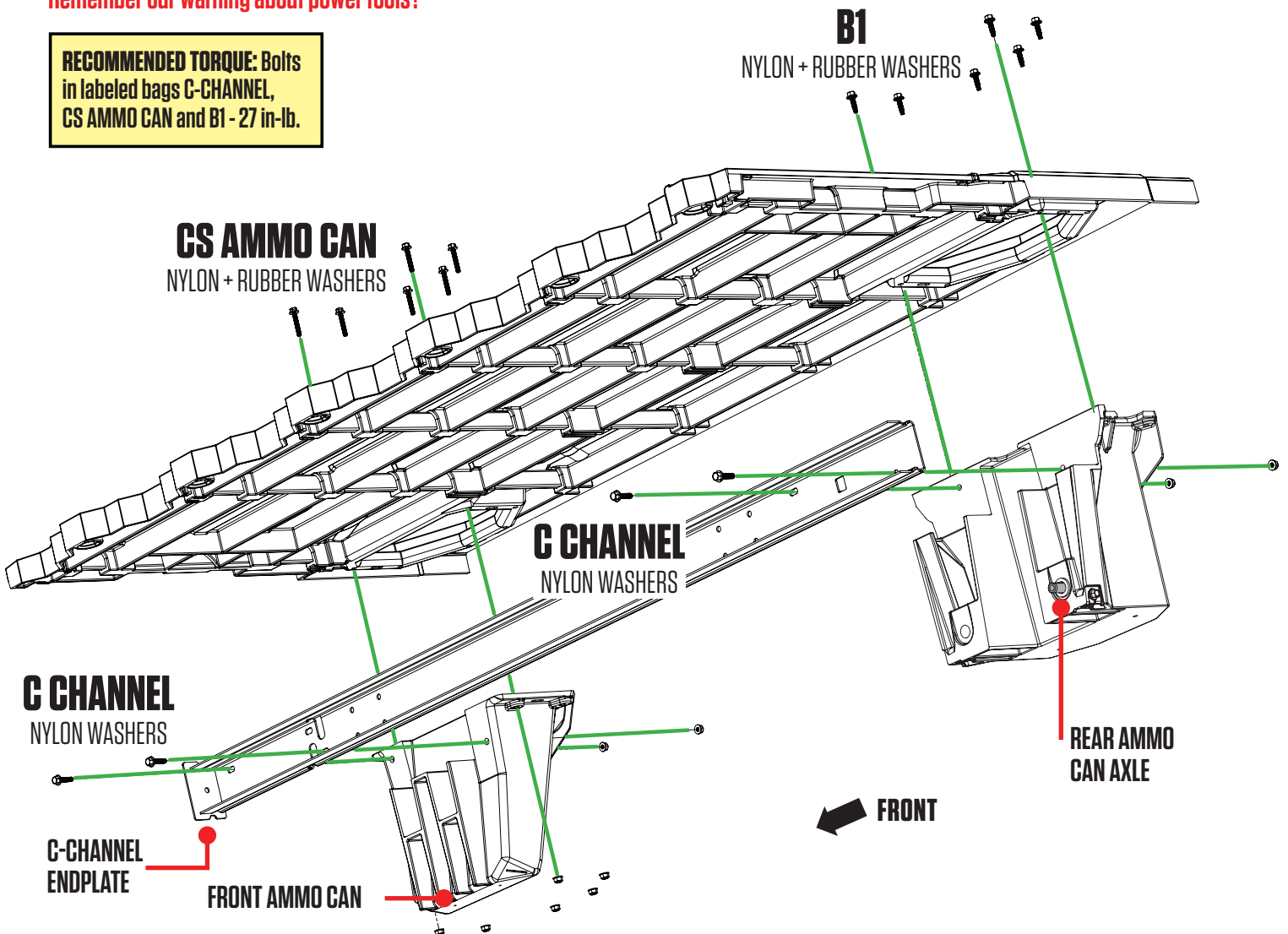

DRAWERS: BRACKETS + WHEELS

(EASIER THAN FALLING OFF A LOG)

- Each drawer has a left and a right bracket. Bolt the brackets into place via bottom two holes in bracket with 3/4" length bolts. Use the 2" length bolt for the upper cabside wall hole in bracket; **BAG DRAWER 1**.
- Install a tube brace in each drawer with two 3/4" length bolts; **BAG DRAWER 1, BAG DRAWER 3**.
- Attach wheels onto the drawer brackets with a 7/32" hex wrench; **BAG WHEELS**.

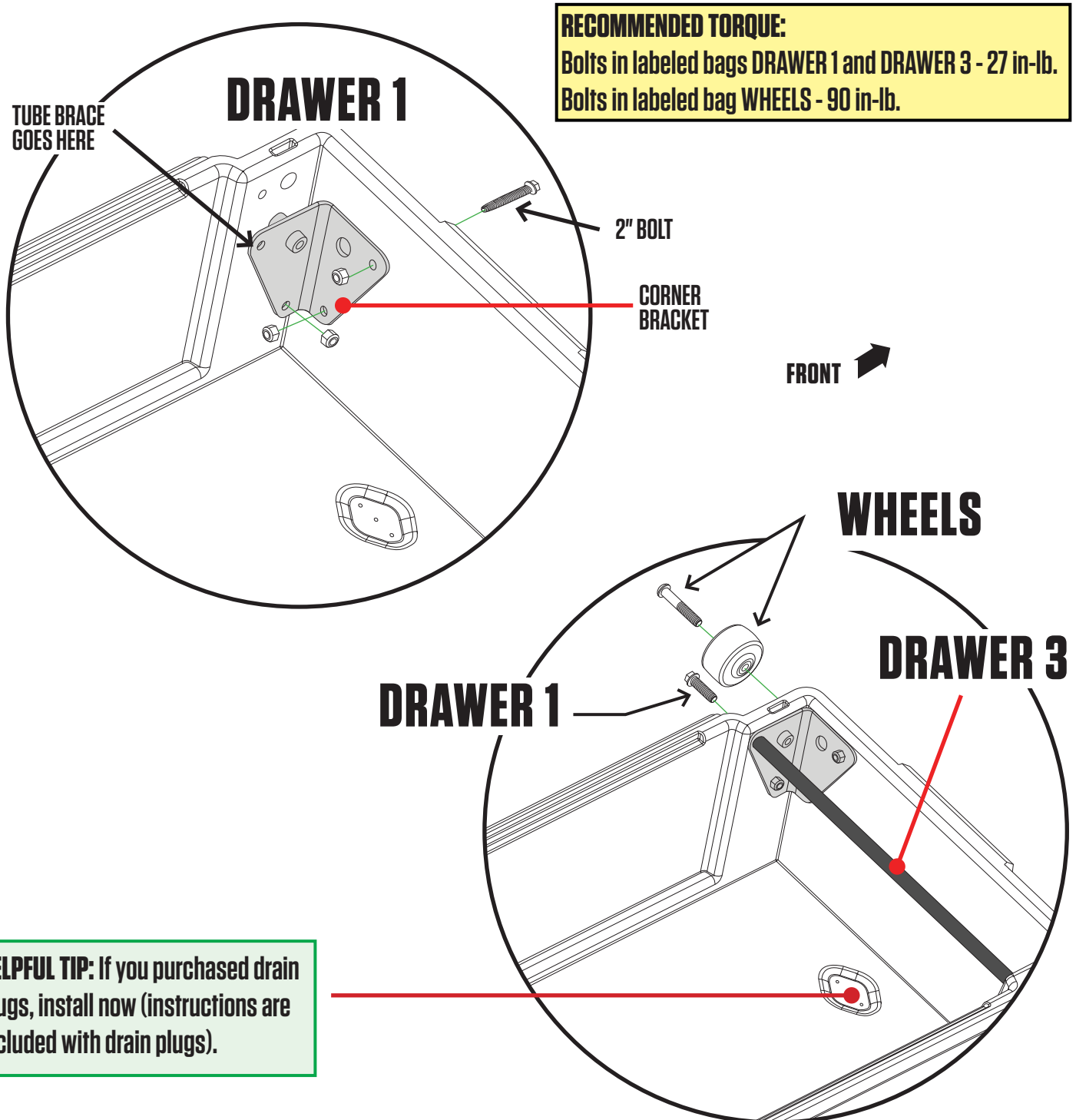

INSTALL: DRAWER HANDLES

- OK, Sparky, one drawer handle assembly needs to be installed by you. We did the other one.
- Save yourself the headache, watch this short installation video: [DECKED.com/videohandle](https://www.decked.com/videohandle).
- From the **underside** of drawer, place the springs into the cavities on either side of the handle slots, red spring=right spring; **BAG HANDLE**. **NOTE: Each spring arm should point inward, not outward.**
- Install a clevis pin through each outside drawer hole and through spring; **BAG HANDLE**.
- With DECKED logo facing outward, insert the handle ends behind the spring arms. Rotate the arms of the handle toward the clevis pins, pulling the spring arm downward. When the handle hole is lined up with the clevis pin, push the pin through the handle hole and through the inside drawer hole. Repeat on the other side of the handle.
- Install a hair pin through the clevis pin; **BAG HANDLE**.

HANDLE OVERVIEW

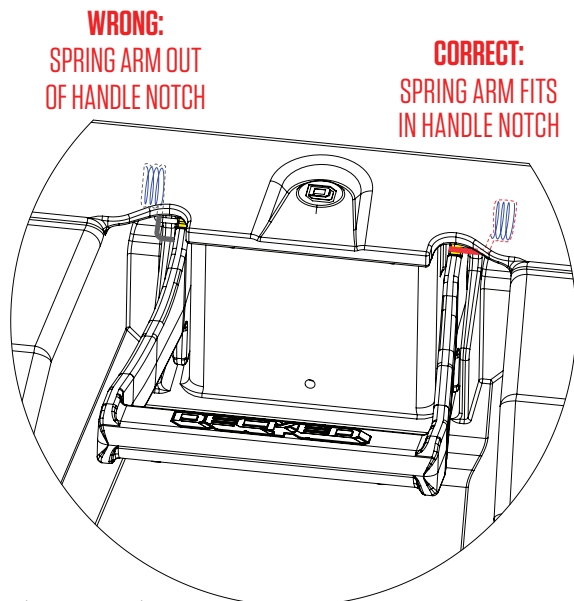
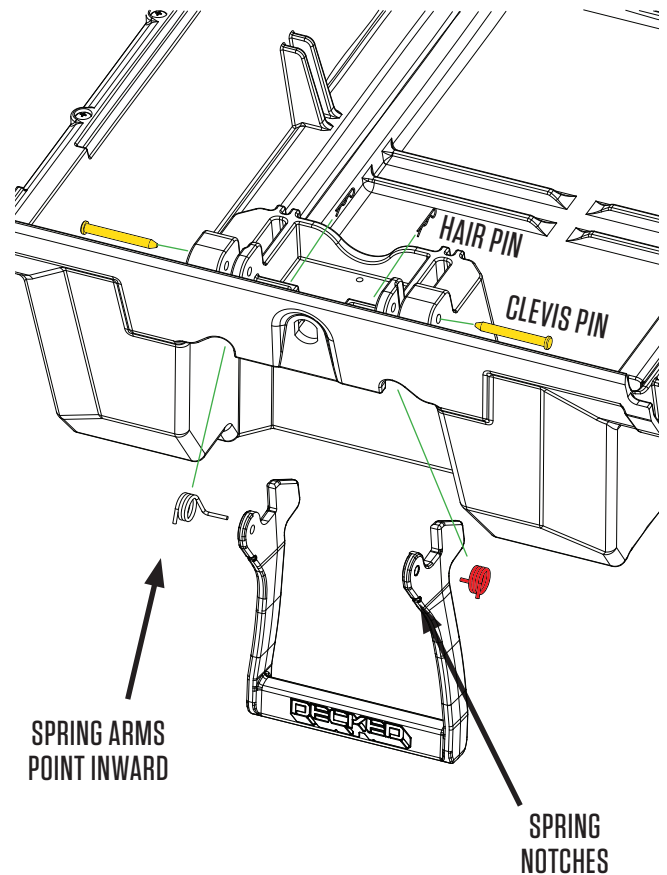
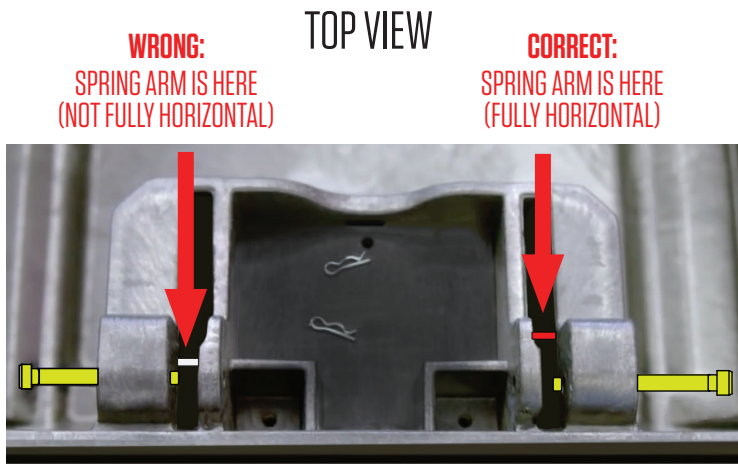

HELPFUL TIP: MAKE SURE SPRINGS HAVE THE LONG ARM HORIZONTAL AND SHORT LEG VERTICAL BEFORE INSERTING HANDLE



INSTALL: DRAWERS

- Prevent acid reflux, watch this short installation video: [DECKED.com/video/tailgatewheels](https://www.decked.com/video/tailgate-wheels).
- Install the drawer by sliding wheels into their two channels (C-channel and center vert), and slide drawer all the way forward until closed.
- Install the remaining tailgate side wheels onto their axles; **BAG WHEELS**.

NOTE: Placing a spacer under the drawer to raise it into position makes this easier (ammo can lids work well, or a small piece of 2x2 or 2x4).

- Install the weather strips on the rear side drawer edge: With the weatherstrip wiper facing towards the front of the van, line up one end with the side of the drawer and place on the top drawer edge, firmly pressing down on the weatherstrip as you move along the drawer edge.

NOTE: Facing the weather stripping the wrong way will funnel water into drawer: BAD!

- When the weatherstrip is fully seated along the top edge, trim off any material that extends beyond the drawer edge with wire cutters. Watch out for the stainless wire coil inside; it's sharp!

**RECOMMENDED TORQUE:
Bolts in labeled bag WHEELS - 90 in-lb.**

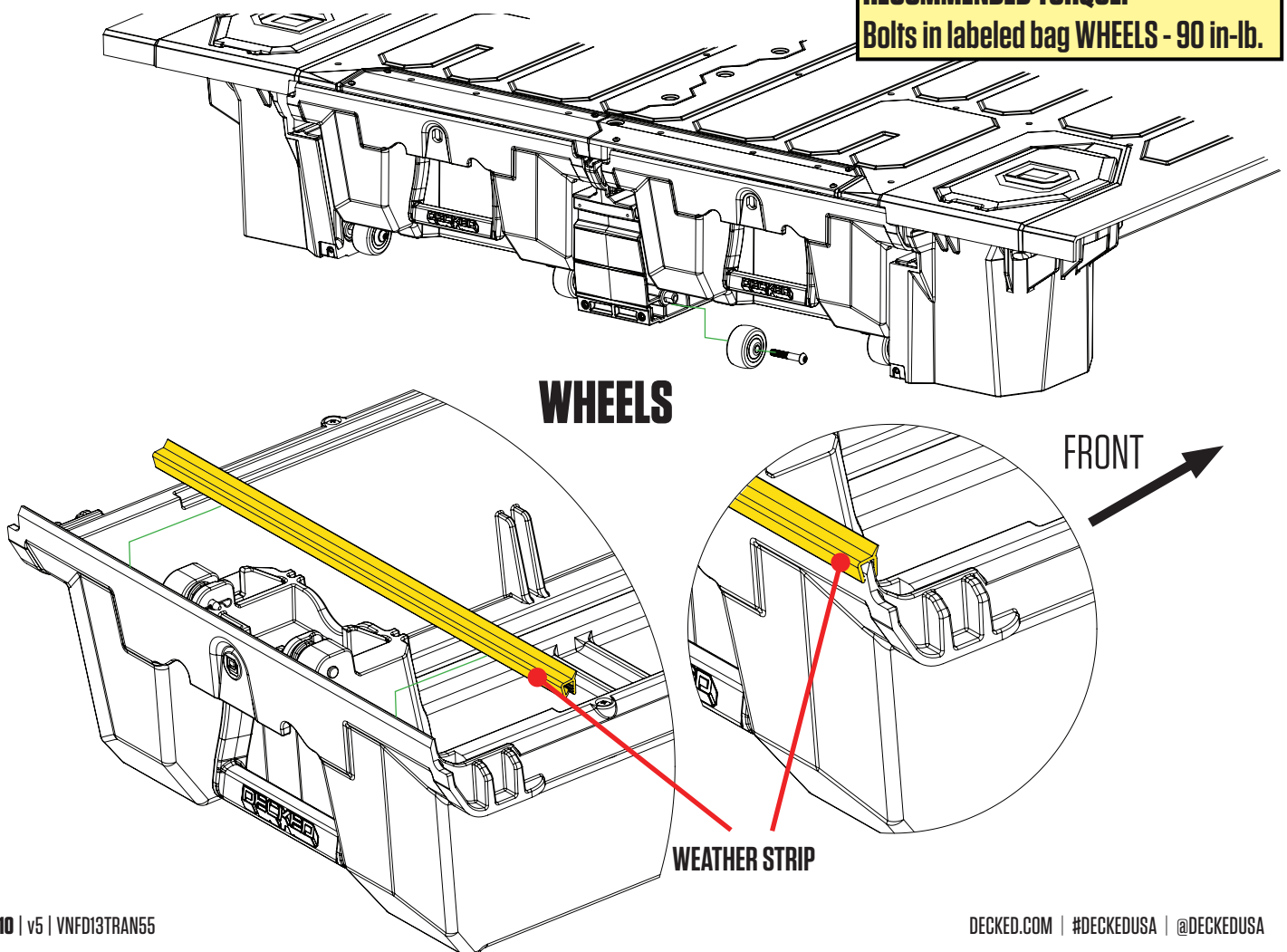

INSTALL: THE FUN STUFF

(WE'RE STILL HAVING FUN RIGHT)

- Use the **WASHERS** bag and **PREP TBO** bag, that is either attached to the torsion brace or in the hardware box, for the following steps.
- Slide torsion brace under center vert and rear ammo cans. Place bottle opener on the outside of the torsion brace.
- Loosely install (start with your fingers to avoid cross-threading):
 - Two 1/2" bolts through upper holes in the bottle opener into the center vert – no washers needed; leave loose.
 - Two 1" bolts with nylon washers through the end holes in torsion brace into rear ammo cans; leave loose.
 - Two 1" bolts with nylon washers through the bottom bottle opener holes and torsion brace into center vert; leave loose.
- Align bottle opener to edges of center vert and tighten four bottle opener bolts.
- Tighten end bolts into rear ammo cans.
- Crack a cold one.

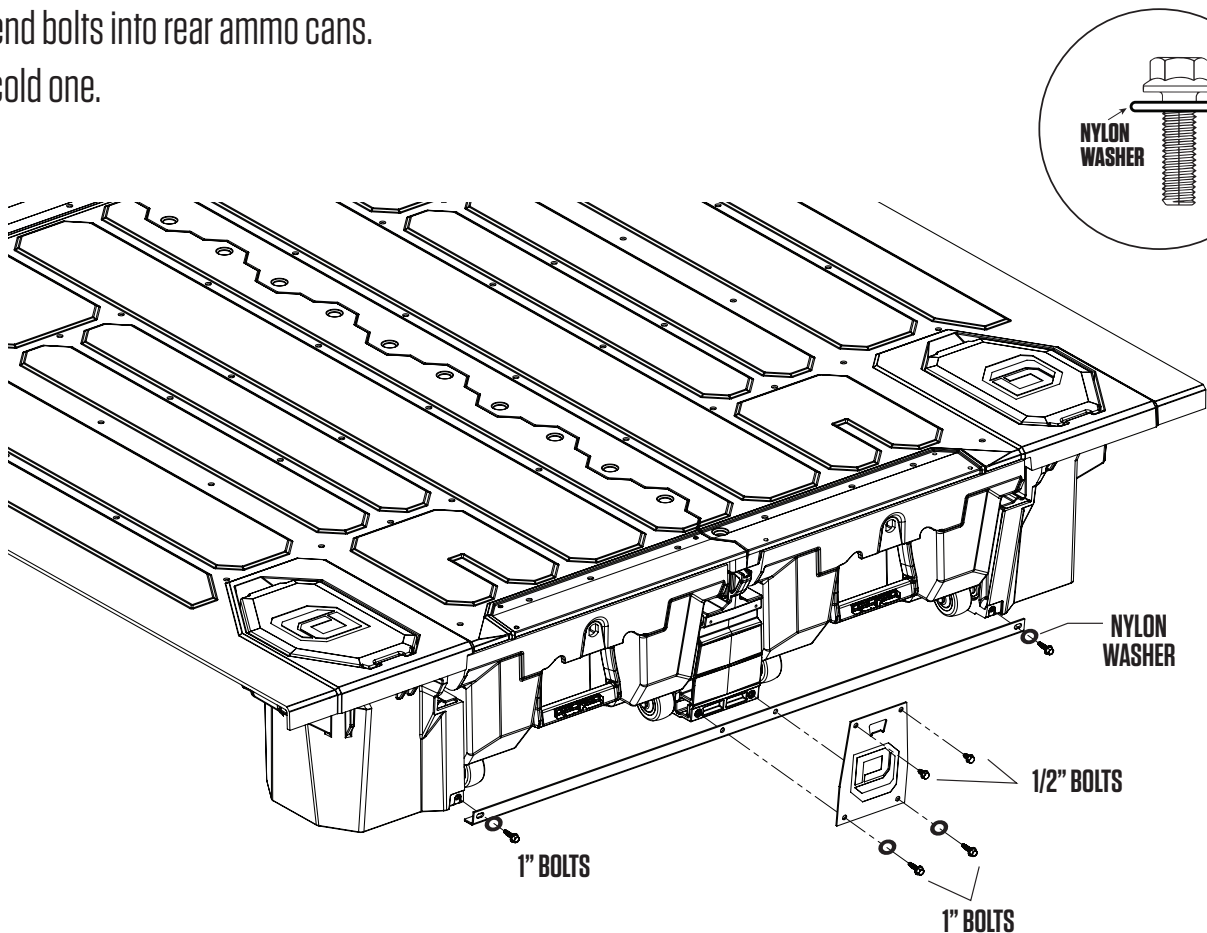

HELPFUL TIP: Bottle opener goes on the **outside** of the torsion brace.

RECOMMENDED TORQUE:
1" Bolts - 27 in-lb. | 1/2" Bolts - 18 in-lb.

INSTALL: J-HOOKS

- Insert the J-hook through the **hole shown** on the passenger side rear ammo can and loop J-hook through tie down or mounting bracket in bed. Assemble with black spherical washer, flat washer and nut; **BAG J8**. Don't tighten yet. If you do, you won't be able to center the system properly in your bed.
- Insert the J-hook through **hole shown** on the passenger side front ammo can and loop J-hook through tie down or mounting bracket in bed. Assemble with black spherical washer, flat washer and nut; **BAG J7**. Don't tighten yet.
- Repeat with J-hooks and ammo cans on drivers side.

IMPORTANT: Leave all J-hook nuts loose.

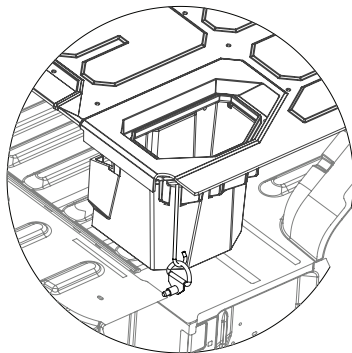
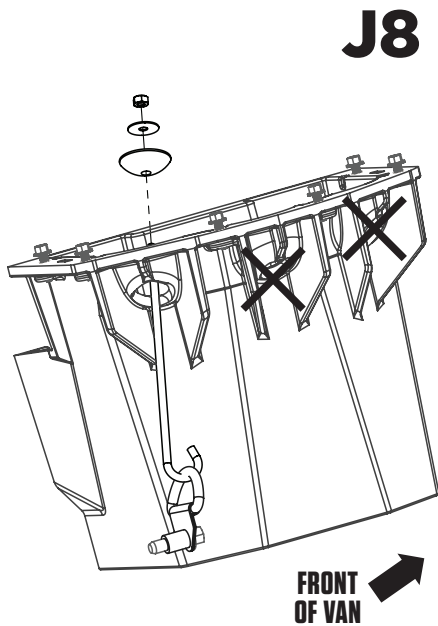

PASSENGER SIDE
REAR AMMO CAN

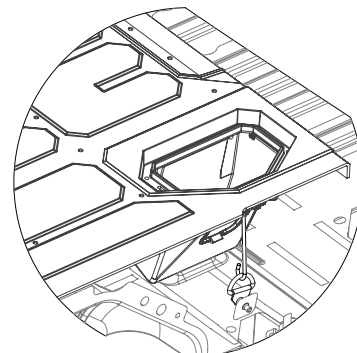
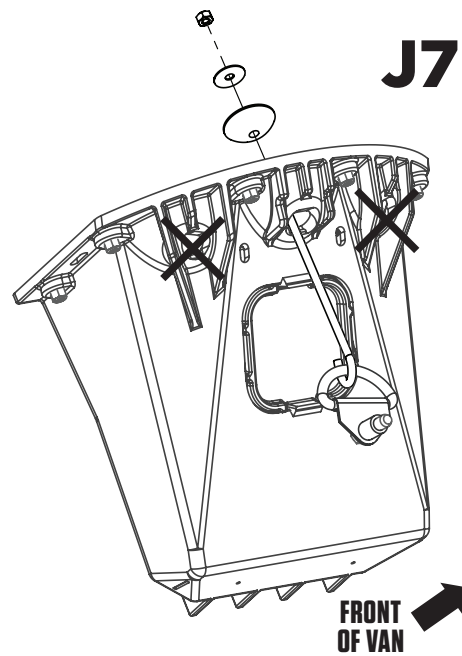

PASSENGER SIDE
FRONT AMMO CAN

TIGHTEN: J-HOOKS

- Finally, tighten the J-hooks, gradually and alternatively. **DO NOT OVER TIGHTEN.**
IMPORTANT: Make sure to center the vert in the center of your bed. Don't worry about side gaps, center the vert on the center rib of the bed.
- Install thread bolt protectors on J-hook ends, if provided.
- Install ruler by aligning the ruler holes with the inserts in the decks. Use your fingers to start the 1/4" screws to avoid cross-threading. Tighten just until snug with a 1/8" Allen wrench.
- Insert lock core plugs, or install locks if purchased.
- Nice job. Your mother and I are very proud of you.

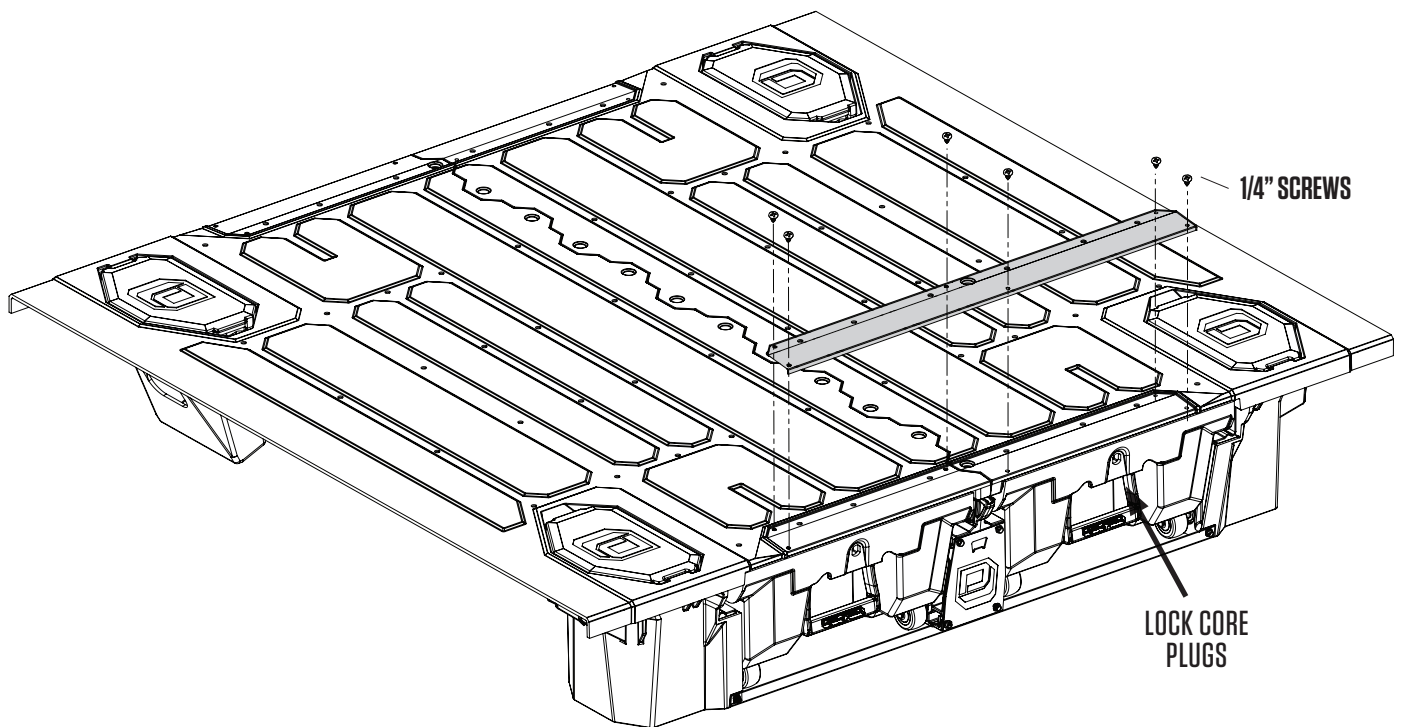

RECOMMENDED TORQUE: J-hooks - 9 in-lb.

INSTALL: SIDEBOARDS

- Identify driver side 'L' shaped plastic sideboard.
- Center the sideboard front to rear on the deck panel.
- Push vertical leg of sideboard up against the interior side panel of van.
- Using the holes in the sideboard as a guide, install self-tapping screws; **BAG SIDEBOARDS**.
- Repeat the process for the passenger side of the system.

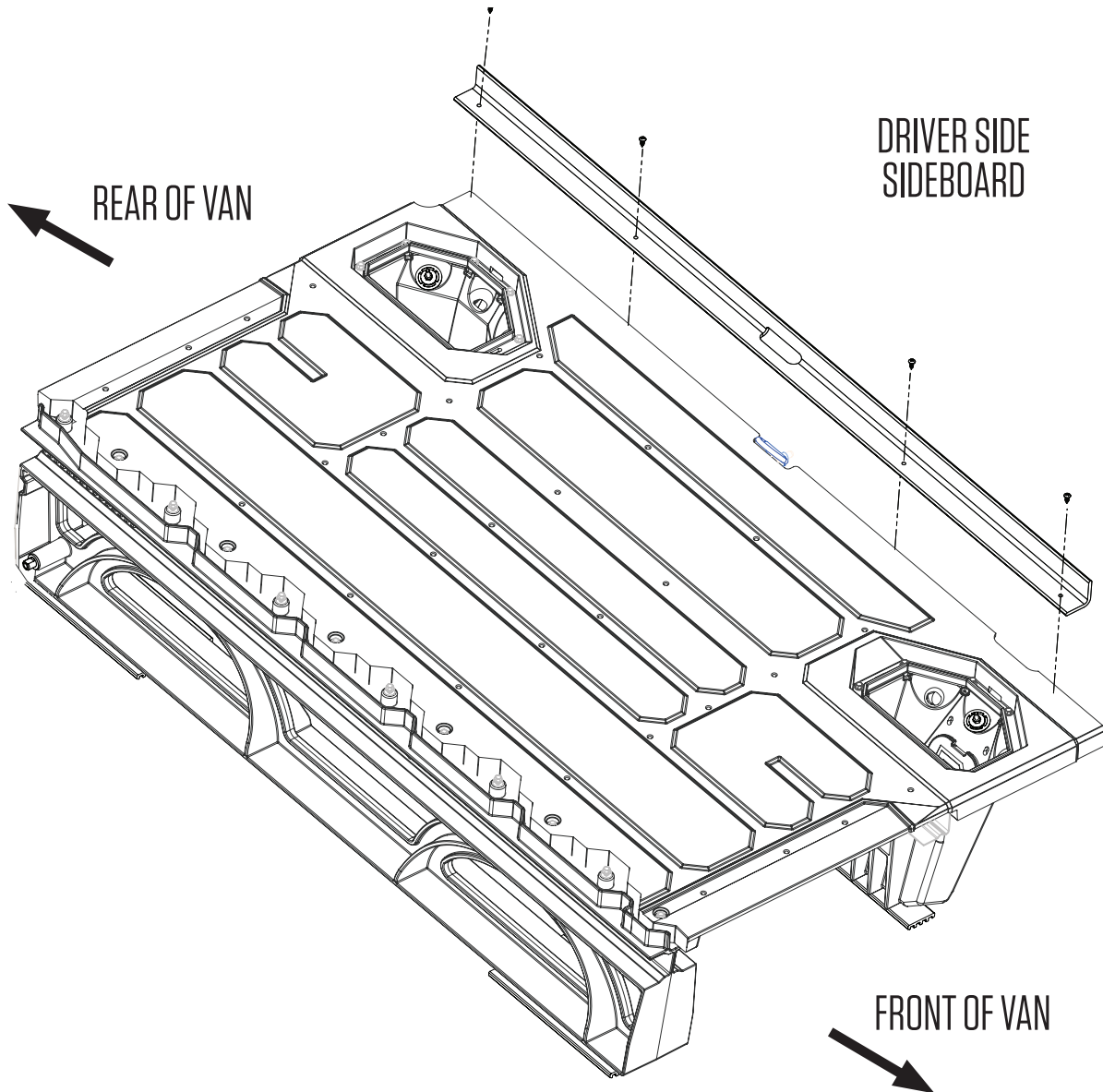

IMPORTANT: Grab your favorite beverage, crack 'er open in the bottle opener and make a toast to your van. You did it. Immediately post a photo of your significant other, child or canine (in no order of significance - please someone show us your pet alligator) appreciating your accomplishment. Add hashtag #DECKEDUSA | @DECKEDUSA.

DECKED 3-YEAR LIMITED WARRANTY

(a.k.a. LEGAL MUMBO JUMBO)

DECKED LLC warrants to the original purchaser of this product that the product will be free from manufacturing defects in workmanship and materials for a period of three (3) years from the date of the original purchase. If within three (3) years from the original date of purchase this product fails due to defect in materials or workmanship, DECKED LLC will replace any defective part at its option.

The original purchaser must contact the DECKED LLC customer service team and provide a description of the defective part, including digital pictures if requested, with the original purchase documentation as validation of warranty coverage or have previously activated their warranty online.

This warranty DOES NOT cover or apply to:

- Damage to the product due to misuse, mishandling and abuse.
- Products not used in accordance with the manufacturer's instructions or recommendations.
- Product not assembled or installed according to manufacturer's instructions.
- Normal wear and tear.
- Undeclared damage to the system during shipping, acts of God. In addition, consequential damage and incidental damages (including lost time) such as damage to persons or property are not covered under this warranty.

REGISTER YOUR PRODUCT FOR ANY FUTURE WARRANTY NEEDS. [DECKED.COM/REGISTER](https://www.decked.com/register)



WARNING!

This product **MUST BE INSTALLED** in conjunction with a **bulkhead wall**, and/or **adequate structural framework** to prevent injury as a result of a traffic accident.

MADE IN THE USA

#DECKEDUSA | @DECKEDUSA