



Installation Instructions: DG5

CHEVY SILVERADO/GMC SIERRA 8' BED LENGTH

1500: (2007-2018)

2500 & 3500: (2007-2019)

1500: (2019 - CURRENT LD/LIMITED: OLD BODY STYLE)

TOOLS REQUIRED

- 3/8" socket
- 7/16" socket
- wire cutters
- 1/8" hex wrench
- 7/32" hex wrench
- 1/2" drill bit
- electric drill
- 5/16" drill bit
- drill stop



SCAN ME

REGISTER YOUR SYSTEM



SCAN ME

INSTRUCTION VIDEOS

Watch short installation videos at www.decked.com/video | Register your system at www.decked.com/warranty

FOLLOW US:      @DECKEDUSA | #DECKEDUSA

VERSION 7

DECKED.COM | 208.806.0251

RC175

CONTENTS

DECKED carton

- LEFT/DRIVER DECK HALF - 1
- RIGHT/PASSENGER DECK HALF - 1
- CENTER VERT - 1
- DRAWER - 2
- CABSIDE AMMO CAN - 2
- TAILGATE SIDE AMMO CAN - 2
- AMMO CAN LID - 4
- AMMO CAN WINDOW - 2
- C-CHANNEL - 2
- RULER - 1
- HARDWARE BOX - 1
- TORSION BRACE - 1
- BOTTLE OPENER - 1
- GUTTER ANGLE - 1

Hardware box - unbagged components

(inside DECKED carton):

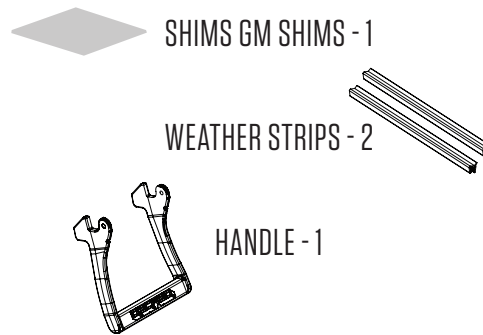

HARDWARE box - bagged components

- PREP 8'S - 1
- PREP TBO - 1
- C-CHANNEL - 1
- BOLT 1 FS (B1) - 1
- CS AMMO CANS - 1
- J5 - 4
- DRAWER 1 - 1
- DRAWER 3 - 1
- HANDLE - 1
- WHEELS - 1
- PREP-EXTRA - 1
- WASHERS - 1
- 8 CLOSEOUT KIT - 1

ASSEMBLY OVERVIEW

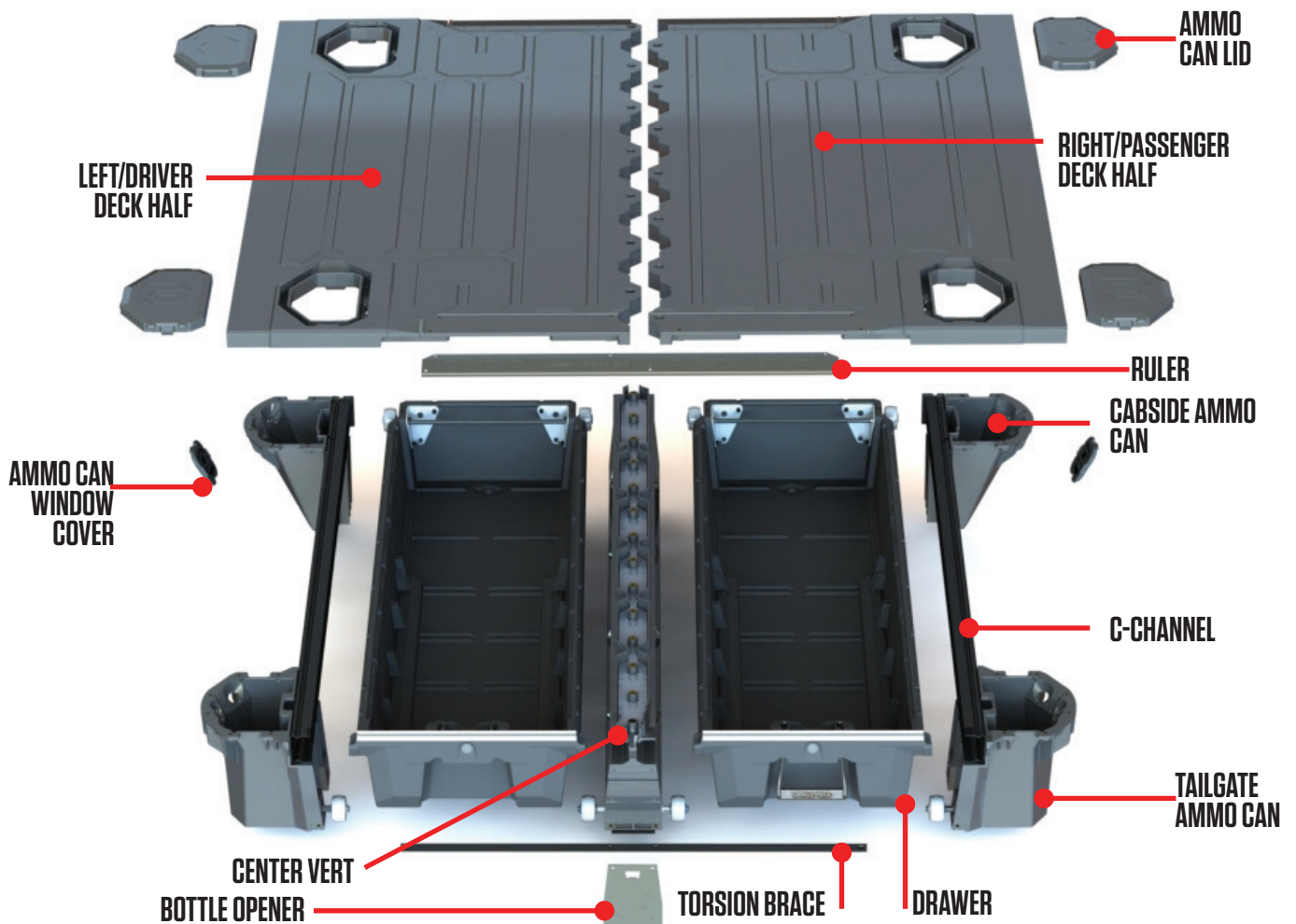

▼ HEY! TORQUE BOY: READ BEFORE YOU INSTALL DECKED ▼

1. **DON'T** go rogue on us, please read the instructions.
2. **DON'T** over tighten bolts, get em' hand-tight.
3. **DON'T** use power tools.
4. If you don't follow directions and *do* use power tools:
 - 1). Set clutch at a very low setting. 2). If you blow it, see NOTE.*
5. Start all bolts with fingers to avoid cross-threading.
6. **DON'T** over tighten J-hooks during installation. Just get 'em good and snug; enough to keep the system from moving in the bed.
7. Nice job if you're still reading.

NOTE* Two extra threaded inserts are included in **BAG PREP-EXTRA**. That's all you get, unless you call us and ask for more. The inserts will replace any stripped inserts in the tailgate ammo cans or front face of the center vert at the bottle opener, but **NOT THE TOP OF THE CENTER VERT**, so hand tighten until snug only! You can also screw the inserts back in if dislocated. There is a straight screwdriver slot on the underside of the threaded insert.

TAILGATE ammo cans have wide bottoms; **CABSIDE** ammo cans have narrow bottoms.

NOTE: You will need a buddy to help with exactly two steps.

*Prevent embarrassing, expletive-filled language,
watch our detailed installation video or give us a call. We're happy to help!*

208.806.0251 | DECKED.COM/INSTALLVIDEO

AMMO CAN DRAIN HOLES

(TO DRILL OR NOT TO DRILL.)

• Do you use a tonneau or shell over your DECKED system?

There is no need to drill holes, unless you leave your tonneau open in a deluge.

• Does your DECKED system live outside?

The ammo cans will get water in them. You'll need to drill holes in the ammo cans.

There are two dimples in the bottom of each ammo can. Drill a 1/2" hole at each dimple. A smaller hole will get clogged.



PREP BED

(JUST LIKE YOUR MOMMA TAUGHT YOU.)

- 1) Using the dimensions in the view below, find the location for the DECKED brackets; **BAG PREP 8'S**; on both sides of the truck, referencing location from existing factory tie-down brackets.
- 2) Use the DECKED bracket as a guide to mark hole locations on the inside bed wall.
- 3) Attach a drill stop to 5/16" drill bit and set depth of drill stop to be 1/4" from tip of drill bit.

NOTE: Extreme caution must be taken when locating and drilling holes. Not using a drill stop could cause damage to fuel lines and hoses, possibly causing a fire or explosion.

- 4) Using drill with drill stop, drill two 5/16" holes at locations marked in step 2.

NOTE: Once you have drilled the holes into the vehicle, the raw metal edges should be sealed using a self-etching primer to resist corrosion and potential fastener point failure.

- 5) Place tie-down bracket up against side panel and place bolts through holes.
- 6) Have a buddy position themselves underneath the vehicle, so they can install the backing plate and nuts over the bolts.
- 7) While holding head of bolts, have your buddy tighten the nuts with a wrench or ratchet.
- 8) **REPEAT** process for opposite side of truck.

16 7/8" from center of factory tie-down bracket to center of DECKED tie-down bracket.

1/4"

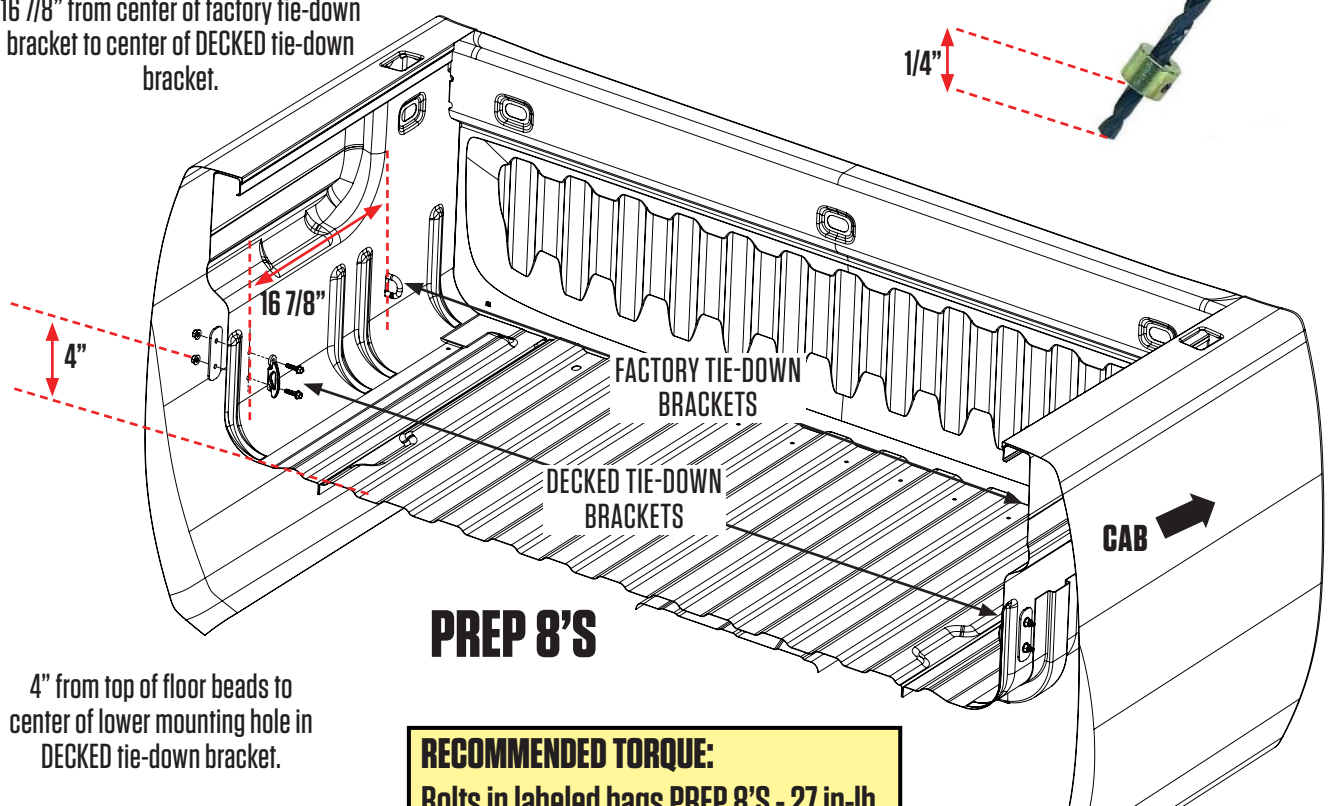

ASSEMBLY: DRIVER'S SIDE DECK

(LET'S DO THIS!)

- There are three pre-installed gaskets – one on the center vert, one on each underside of the decks where they rest on the center vert. Do yours look weird? (They should be flat.) See them here: [DECKED.COM/GASKETS](https://www.decked.com/gaskets)
- Place C-channel on the **inside** ledges of a cabside ammo can and a tailgate ammo can.
- The end of the C-channel with the endplate must rest on the cabside ammo can.
- Verify that the tailgate ammo can's axle is closest to the tailgate; if not, grab the other tailgate ammo can.
- Install nylon washers onto all bolts in **BAG C-CHANNEL, WASHERS**.
- Loosely bolt C-channel to the two ammo cans. Make sure the bolt head is in the C-channel, not inside the ammo can; **BAG C-CHANNEL**. Don't tighten yet. Houston, come in Houston, do you copy? Don't tighten yet.
- Line up the driver's side deck (sticker or mark on end of deck panel indicates LEFT/DRIVER) on top of the C-channel/ammo can assembly and the center vert bosses. **Hey Sparky: Tailgate end of the center vert has an axle installed; the center vert axle and ammo can axles must be on the tailgate end (not cabside end) of the assembly.**
- Use **WASHERS** bag to install nylon & rubber washers on all CS AMMO CAN bolts. Install the same washers on 12 **B1** bolts.
- Use the above bolts to bolt the deck to the ammo cans; **BAG B1** for the tailgate ammo can, **BAG CS AMMO CAN** for the cabside ammo can.
- **Now tighten the loose bolts connecting the ammo cans to the C-channel.**
- Bolt the deck to the center vert; **BAG B1** (no washers). **If you must use power tools, use with caution!**
Set drill clutch to LIGHT.

DRIVER SIDE DECK HALF

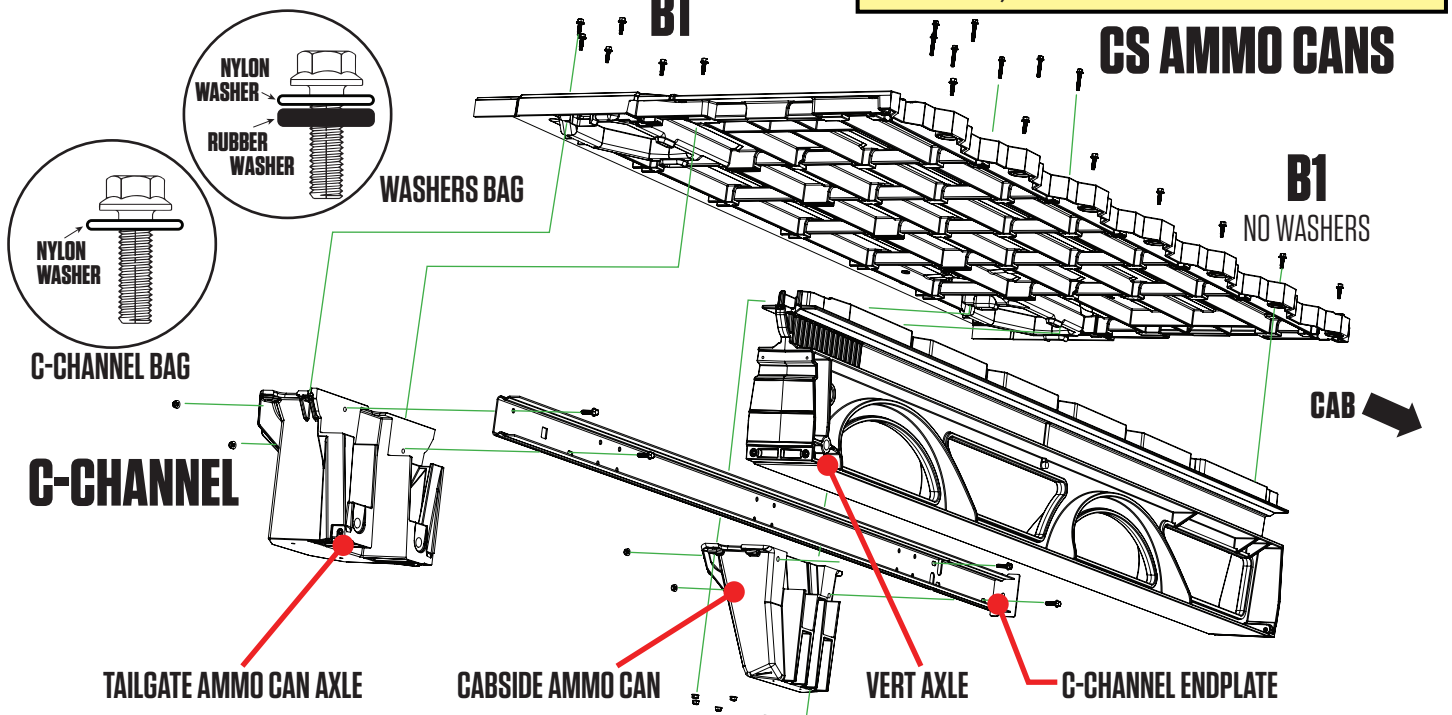

ASSEMBLY: PASSENGER'S SIDE DECK

- Using the assembly just built as a support, assemble the passenger side.
- Place C-channel on the **inside** ledges of a cabside ammo can and a tailgate ammo can.
- The C-channel endplate must rest on the cabside ammo can.
- You should have the correct tailgate ammo can for this step. The axle will be on the tailgate side of the system. If not, swap the tailgate ammo cans now.
- Loosely bolt C-channel to the two ammo cans. Make sure the bolt head is in the C-channel, not inside the ammo can; **BAG C-CHANNEL** (with nylon washers). Deja vu, **don't** tighten yet.
- Line up the passenger's side deck (sticker or mark on end of deck panel indicates RIGHT/PASSENGER) on top of the C-channel/ammo can assembly.
- Bolt the deck to the ammo cans; **BAG B1** (with nylon and rubber washers) for the tailgate ammo can, **BAG CS AMMO CAN** (with nylon and rubber washers) for the cabside ammo can.
- **DO NOT bolt passenger deck to center vert. Do not pass GO! Do not collect \$200...**
- **Now tighten the loose bolts connecting the ammo cans to the C-channel.**
- Grab your buddy to help you lift the driver side assembly into the driver side of the truck bed. Lift the passenger side assembly into the passenger side of the truck bed and seat the passenger side deck on the upstanding, cylindrical vert bosses.
- Bolt the passenger side deck half to the center vert; **BAG B1** (no washers). Make sure all bolts connecting the deck to the center vert are snug. **Remember our warning about power tools?**

PASSENGER SIDE DECK HALF

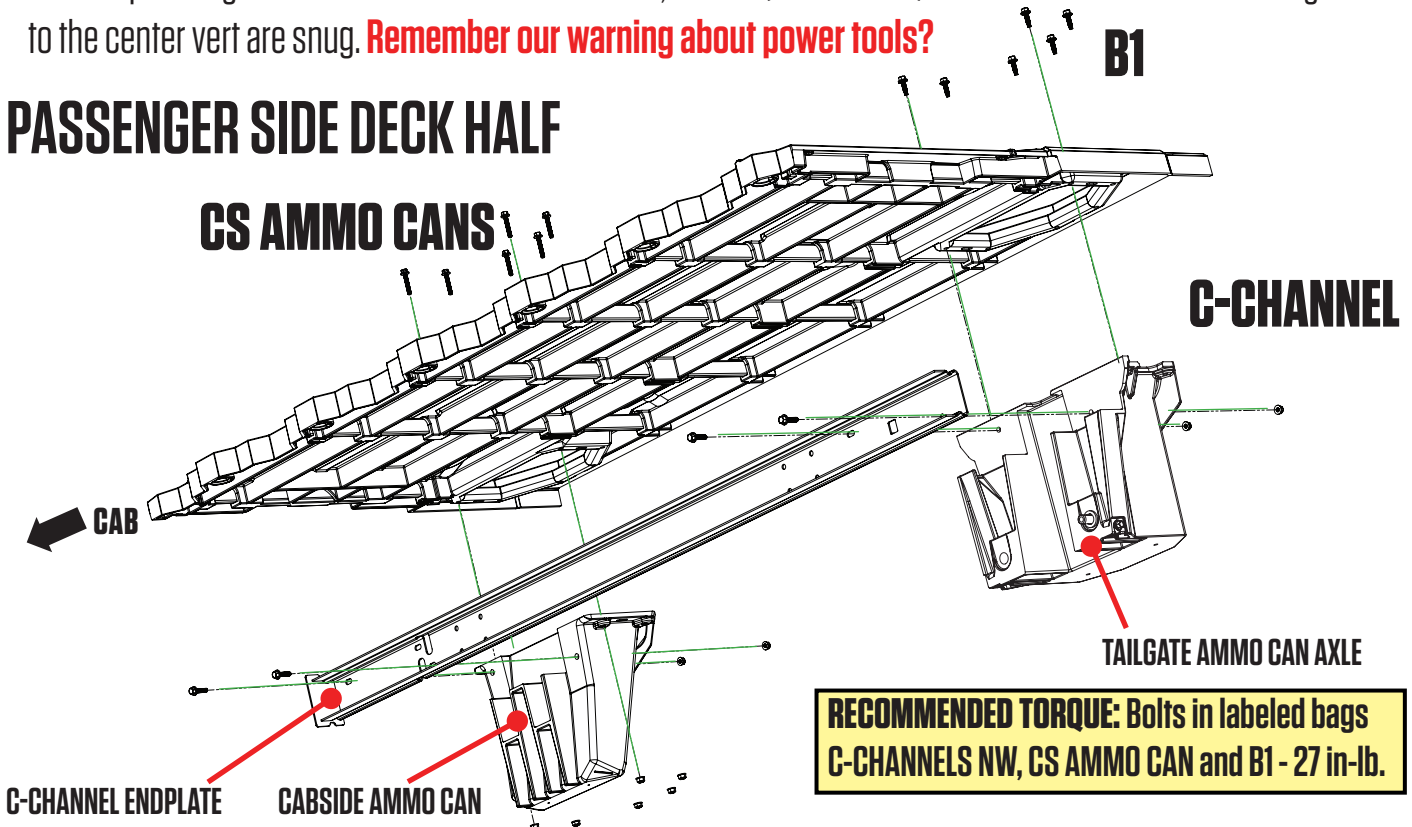

DRAWERS: BRACKETS + WHEELS

(EASIER THAN FALLING OFF A LOG)

- Each drawer has a left and a right bracket. Bolt the brackets into place via bottom two holes in bracket with 3/4" length bolts. Use the 2" length bolt for the upper cabside wall hole in bracket; **BAG DRAWER 1**.
- Install a tube brace in each drawer with two 3/4" length bolts; **BAG DRAWER 1, BAG DRAWER 3**.
- Attach wheels onto the drawer brackets with a 7/32" hex wrench; **BAG WHEELS**.

RECOMMENDED TORQUE:

Bolts in labeled bags DRAWER 1 and DRAWER 3 - 27 in-lb.

Bolts in labeled bag WHEELS - 90 in-lb.

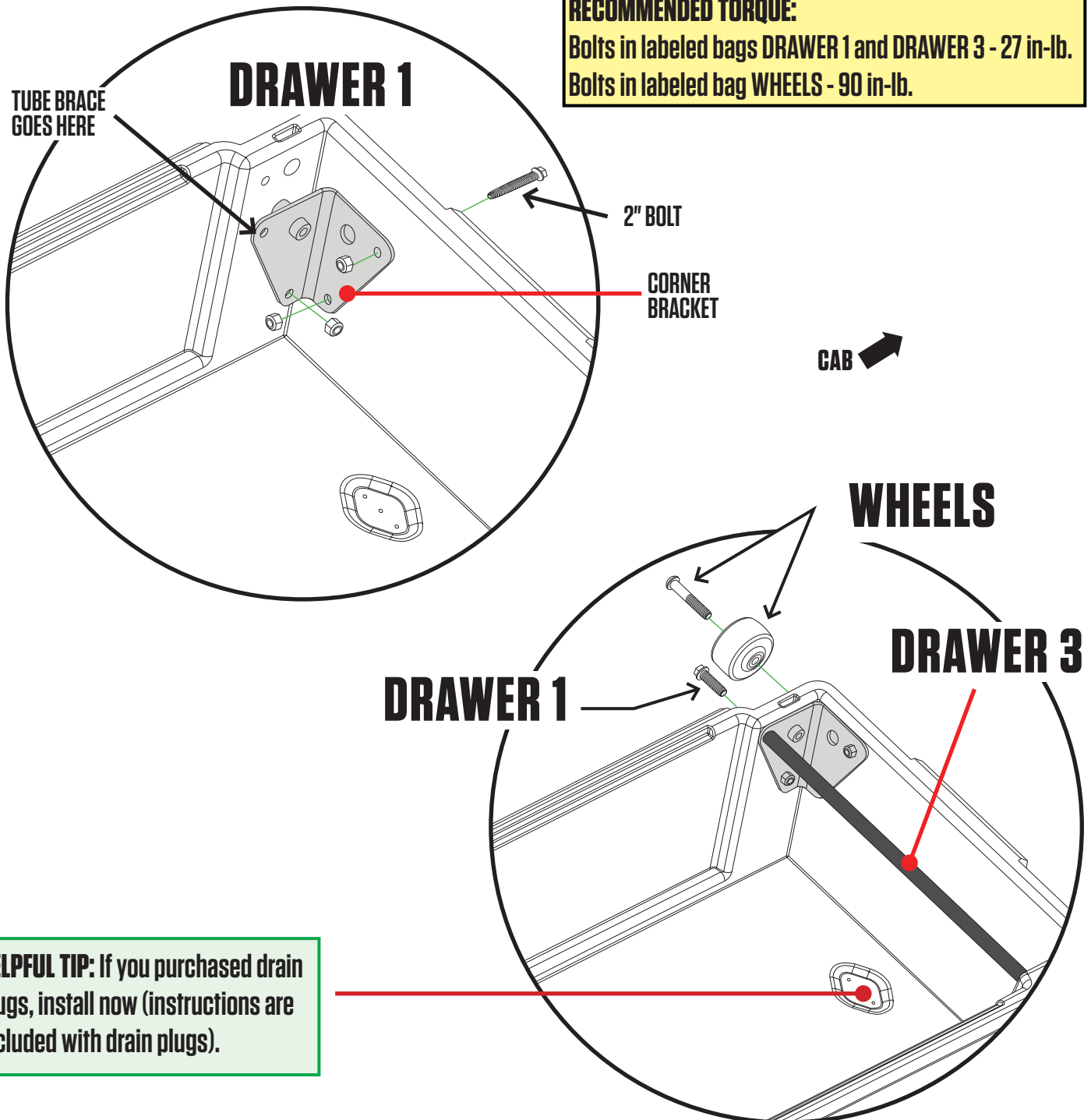

INSTALL: DRAWER HANDLES

- OK, Sparky, one drawer handle assembly needs to be installed by you. We did the other one.
- Save yourself the headache, watch this short installation video: [DECKED.com/videohandle](https://www.decked.com/videohandle).
- From the **underside** of drawer, place the springs into the cavities on either side of the handle slots, red spring=right spring; **BAG HANDLE**. **NOTE: Each spring arm should point inward, not outward.**
- Install a clevis pin through each outside drawer hole and through spring; **BAG HANDLE**.
- With DECKED logo facing outward, insert the handle ends behind the spring arms. Rotate the arms of the handle toward the clevis pins, pulling the spring arm downward. When the handle hole is lined up with the clevis pin, push the pin through the handle hole and through the inside drawer hole. Repeat on the other side of the handle.
- Install a hair pin through the clevis pin; **BAG HANDLE**.

HANDLE OVERVIEW

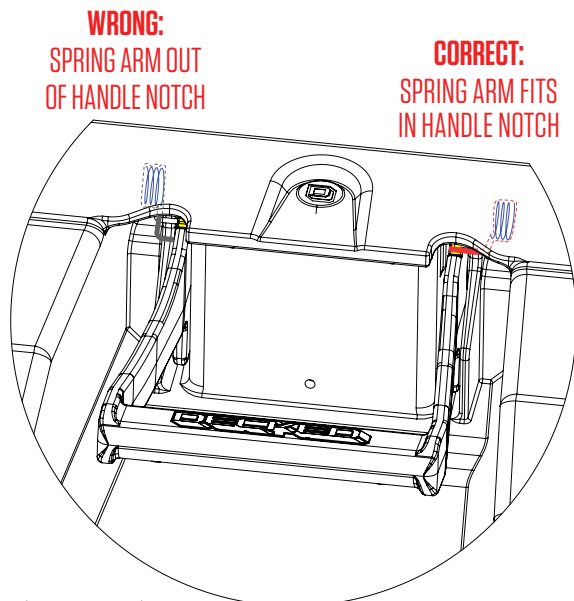
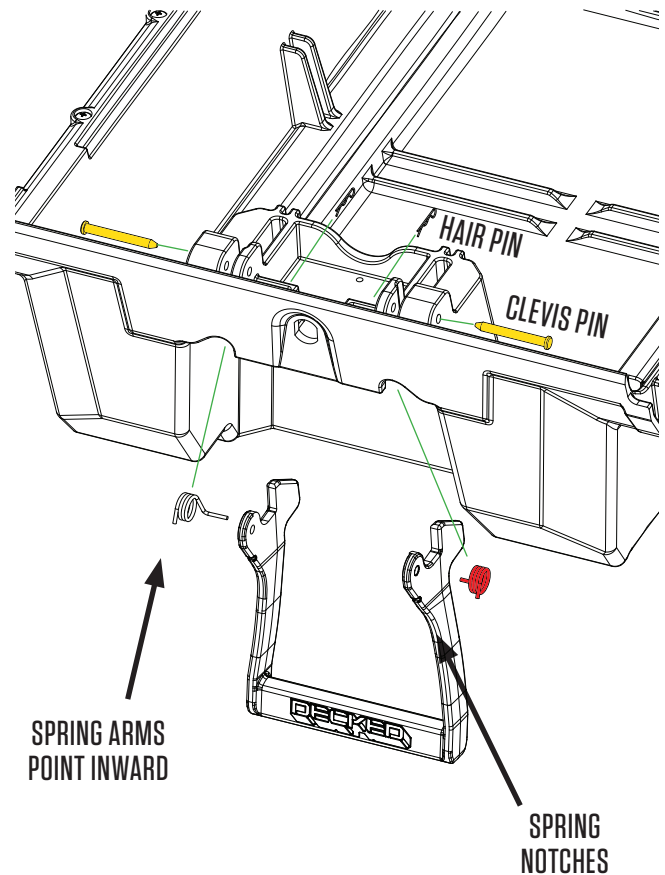
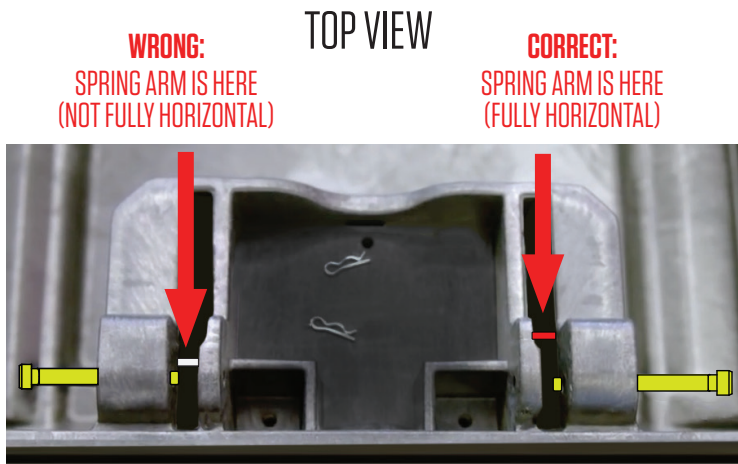

HELPFUL TIP: MAKE SURE SPRINGS HAVE THE LONG ARM HORIZONTAL AND SHORT LEG VERTICAL BEFORE INSERTING HANDLE



INSTALL: DRAWERS

- Save yourself the headache, watch this short installation video: [DECKED.com/videotailgatewheels](https://www.decked.com/video/tailgate-wheels).
- Install the drawer by sliding wheels into their two channels (C-channel and center vert), and slide drawer all the way forward until closed.
- Install the remaining tailgate side wheels onto their axles; **BAG WHEELS**.

NOTE: Placing a spacer under the drawer to raise it into position makes this easier (ammo can lids work well, or a small piece of 2x2 or 2x4).

- Install the weather strips on the tailgate side drawer edge: With the weatherstrip wiper facing cabside, line up one end with the side of the drawer and place on the top drawer edge, firmly pressing down on the weatherstrip as you move along the drawer edge.

NOTE: Facing the weather stripping the wrong way will funnel water into drawer: BAD!

- When the weatherstrip is fully seated along the top edge, trim off any material that extends beyond the drawer edge with wire cutters. Watch out for the stainless wire coil inside; it's sharp!

**RECOMMENDED TORQUE:
Bolts in labeled bag WHEELS - 90 in-lb.**

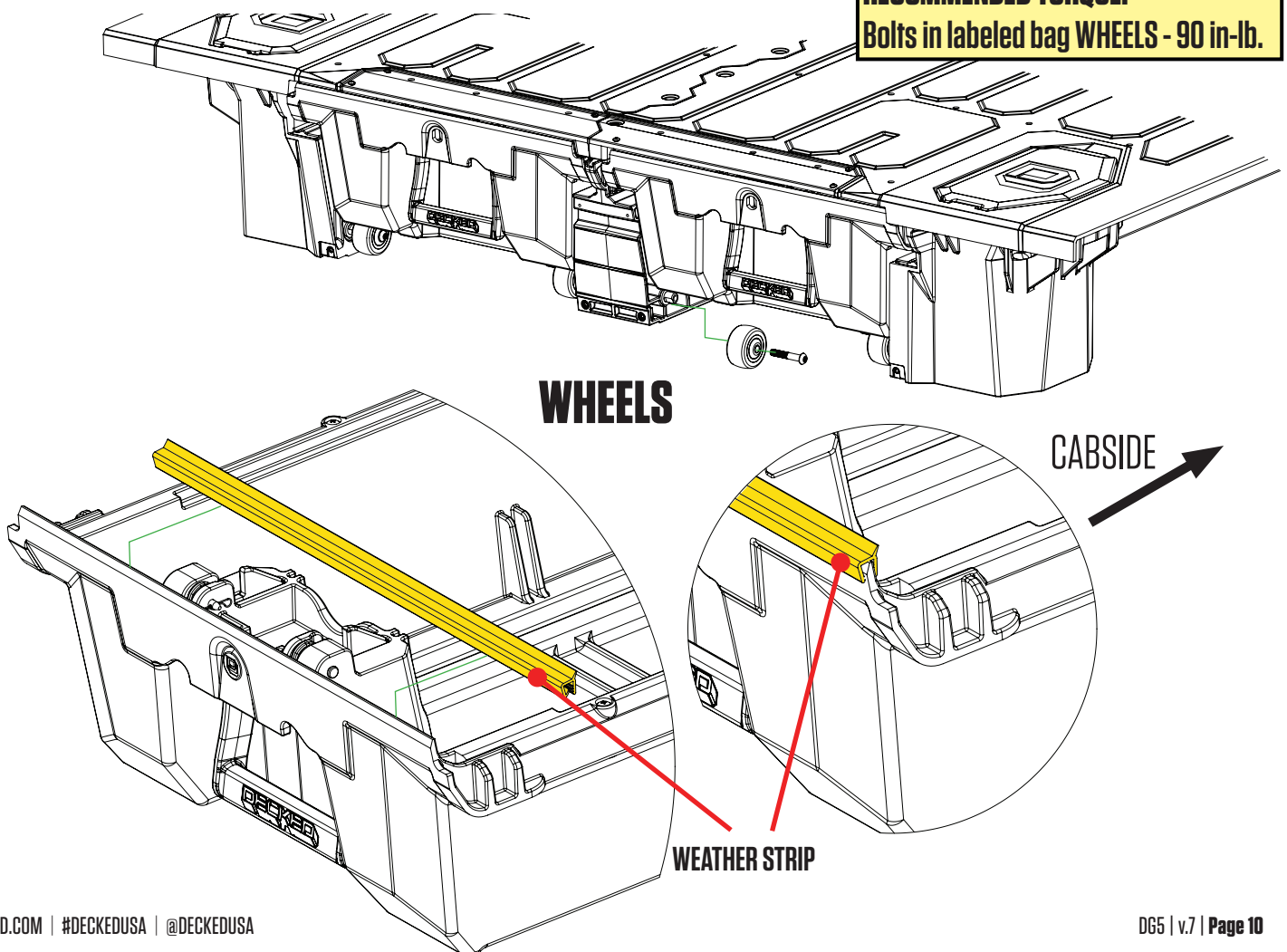

INSTALL: VERT SHIM

- GM truck beds are oftentimes convex front to back. If your truck bed is convex, this Santoprene shim will allow the tailgate end of the vert to rest in full contact with the bed; **BAG GM SHIM.**

NOTE: Not all GM truck beds are convex, only add shim if needed.

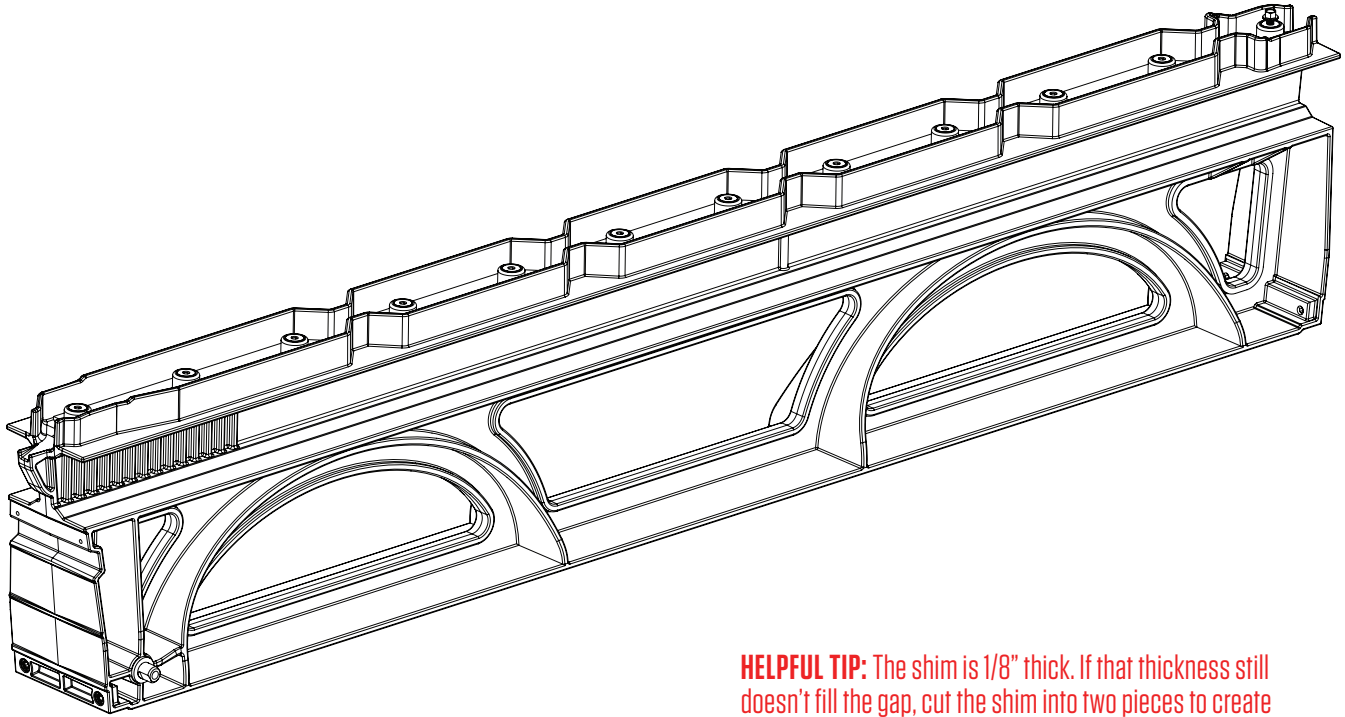

GM SHIM

HELPFUL TIP: The shim is 1/8" thick. If that thickness still doesn't fill the gap, cut the shim into two pieces to create more thickness.

INSTALL: THE FUN STUFF

- Use the **WASHERS** bag and **PREP TBO** bag for the following steps.
- Slide torsion brace under center vert and tailgate ammo cans. Place bottle opener on the outside of the torsion brace.
- Loosely install (start with your fingers to avoid cross-threading):
 - Two 1/2" bolts through upper holes in the bottle opener into the center vert – no washers needed; leave loose.
 - Two 1" bolts with nylon washers through the end holes in torsion brace into tailgate ammo cans; leave loose.
 - Two 1" bolts with nylon washers through the bottom bottle opener holes and torsion brace into center vert; leave loose.
- Align bottle opener to edges of center vert and tighten four bottle opener bolts.
- Tighten end bolts into tailgate ammo cans.

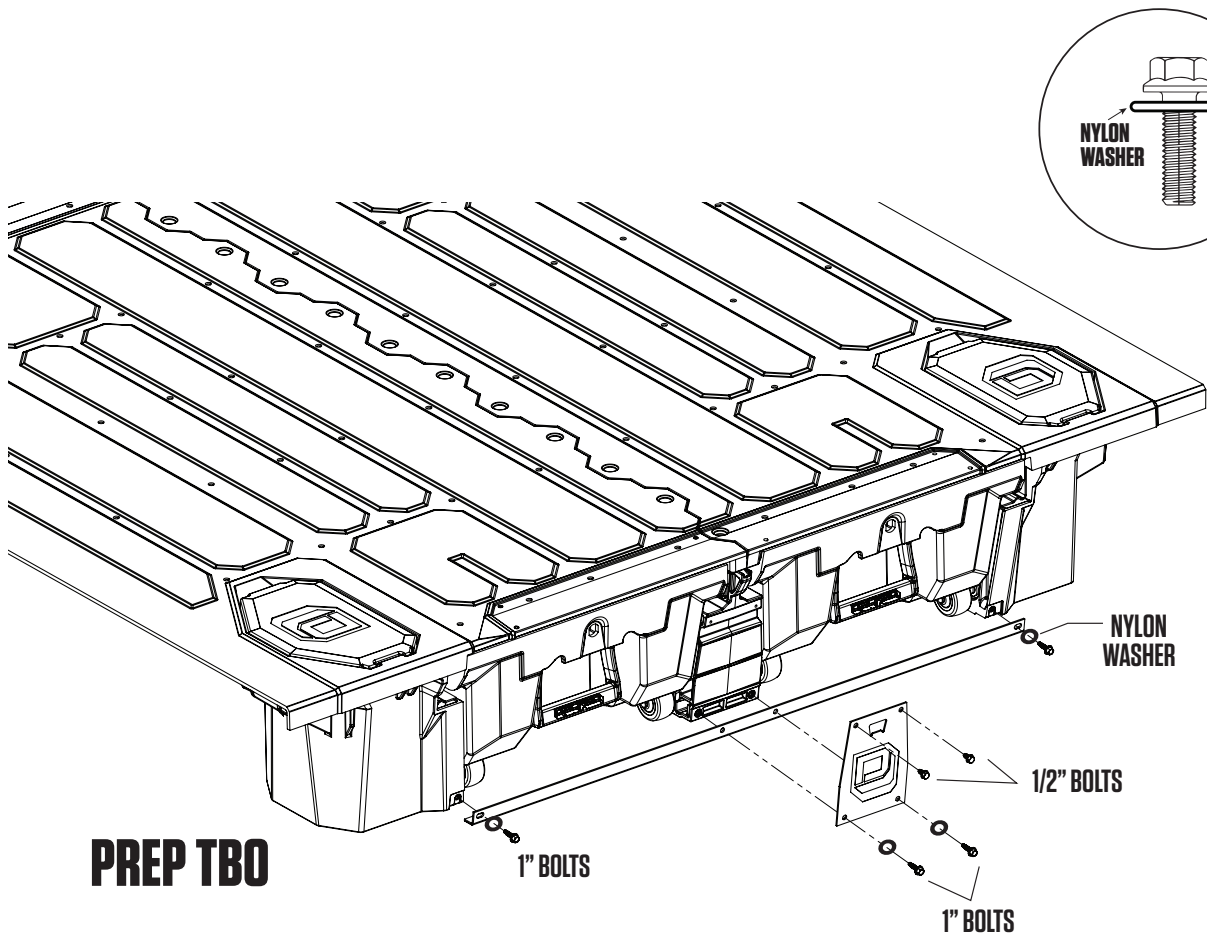

HELPFUL TIP: Bottle opener goes on the **outside** of the torsion brace.

RECOMMENDED TORQUE:
1" Bolts - 27 in-lb. | 1/2" Bolts - 18 in-lb.

INSTALL: J-HOOKS

- Insert the J-hook through the **center** hole on the passenger side tailgate ammo can and loop J-hook through tie down or mounting bracket in bed. Screw on the winged-spherical nut-washer, round side down, on the J-hook and fasten until finger tight; **BAG J5**. Don't tighten yet. If you do, you won't be able to center the system properly in your bed.
- Insert the J-hook through **center** hole on the passenger side cabside ammo can and loop J-hook through tie down or mounting bracket in bed. Screw on the winged-spherical nut-washer, round side down, on the J-hook and fasten until finger tight; **BAG J5**. Don't tighten yet.
- Repeat with J-hooks and ammo cans on drivers side.

IMPORTANT: Leave all J-hook nuts loose.

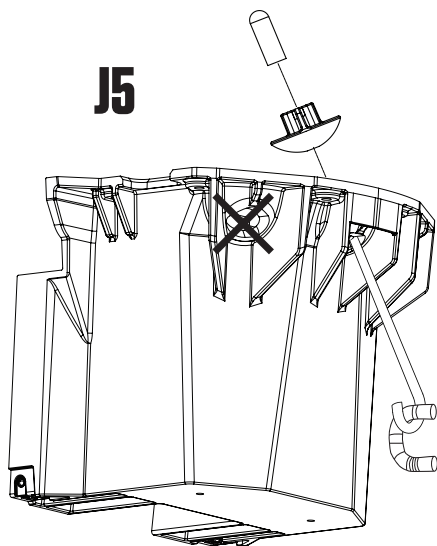

J5

CAB →

PASSENGER SIDE
TAILGATE AMMO CAN

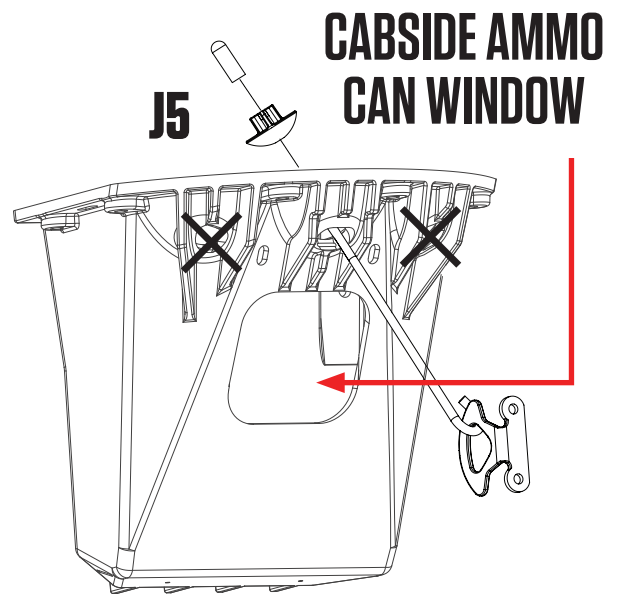

**CABSIDE AMMO
CAN WINDOW**

J5

CAB →

PASSENGER SIDE
CABSIDE AMMO CAN

TIGHTEN: J-HOOKS

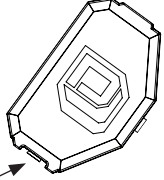
- Tighten the J-hooks, gradually and alternatively. **DO NOT OVER TIGHTEN. IMPORTANT:** Make sure to center the vert in the center of your bed. Don't worry about side gaps, center the vert on the center rib/trough of the bed.
- Place condoms on J-hook ends; **BAG PREP TBO.**
- Install cabside ammo can window covers by engaging bottom tab of the window cover and pushing the top into place (use a screwdriver on the top tab).
- Yo! WAKE UP. Ammo can lids are location specific. Look at your lids. Find the side with two tabs: 
- The tabs point to the outside: **DETAIL A.**
- **If you install the ammo can lids backwards, they will fly off (like the Flying Nun).**
- Install ruler by aligning the ruler holes with the inserts in the decks. Use your fingers to start the 1/4" screws to avoid cross-threading. Tighten just until snug with a 1/8" hex wrench.
- Insert lock core plugs, or install locks if purchased.
- Nice job. Your mother and I are very proud of you.

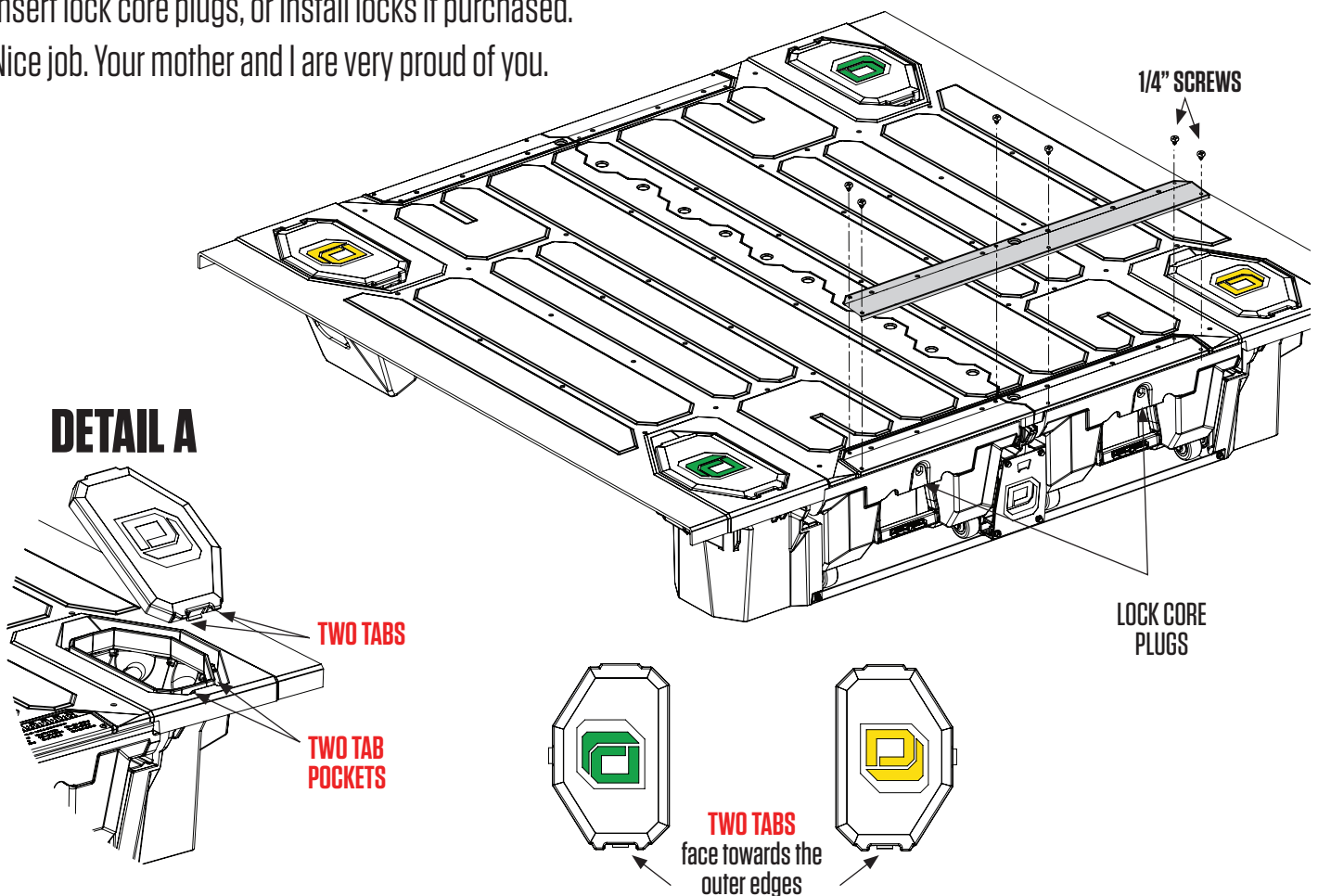

IMPORTANT: Grab your favorite beverage, crack 'er open in the bottle opener and make a toast to your truck. You did it. Immediately post a photo of your significant other, child or canine (in no order of significance - please someone show us your pet alligator) appreciating your accomplishment. Add hashtag #DECKEDUSA | @DECKEDUSA.

INSTALL: DECKED 8' GUTTER ANGLE

The gutter angle is designed to keep water from entering through the exposed cabside of the drawers. The gutter angle must be installed after the DECKED system is installed in your truck.

You may not need this gutter if you have a tool box or auxillary tank in the gap at the cabside.

TOOLS REQUIRED

- **#3 Phillips head screwdriver**
- you'll likely strip out the screws with a #2 - we've done it
- **7/16" wrench**

COMPLETED INSTALLATION:

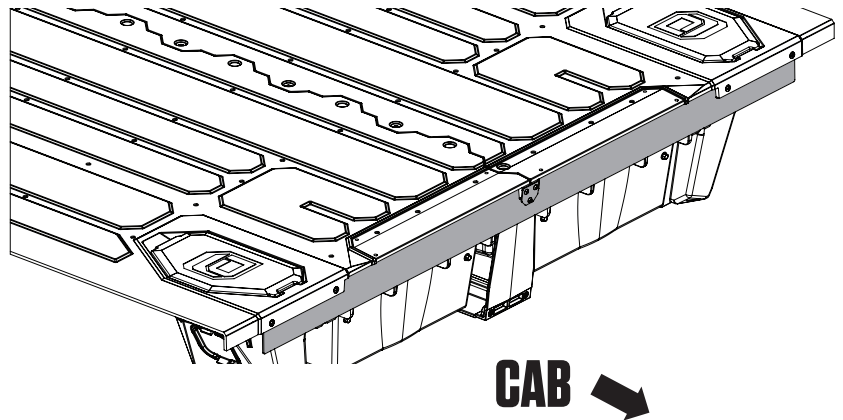

STEP 1

STEP 1: ATTACH CENTER PLATE TO GUTTER ANGLE

Use one of the three, self-tapping screws to install the 'home plate' bracket onto the gutter angle using the existing hole on the gutter angle and the single hole on the bracket. Fasten until snug - there is no nut used here.

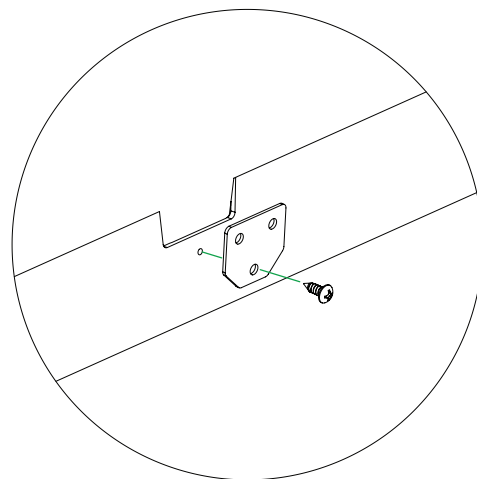

STEP 2: PLACE GUTTER ANGLE

- Align the end holes in the gutter angle with the holes in the deck panel.
- Place the gutter angle behind the overhanging lip on the deck panel.

IMPORTANT; GUTTER ANGLE MUST BE BEHIND LIP!!

- Install the four 1" long screws into the deck panel, gutter angle, and nut.
- **LEAVE LOOSE.**

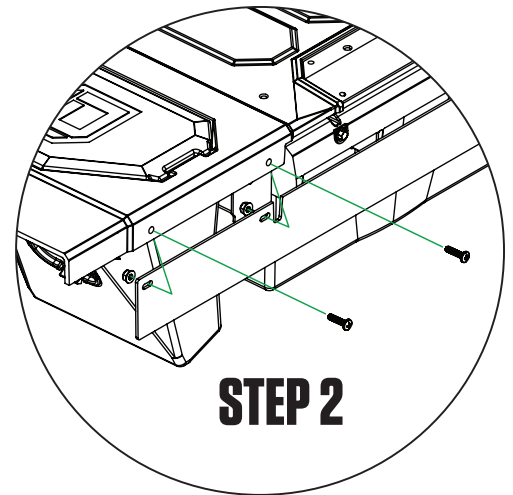

STEP 3: VERIFY POSITION

- This next step is important, so PLEASE pay attention.
- Before securing any fasteners, ensure that the full length of the gutter angle is seated up and under the overhanging lip of the DECKED panel.
- If you see a gap between the DECKED panel and the gutter angle, the gutter angle is not seated high enough in the correct position and water will get into your drawers. **BAD.**

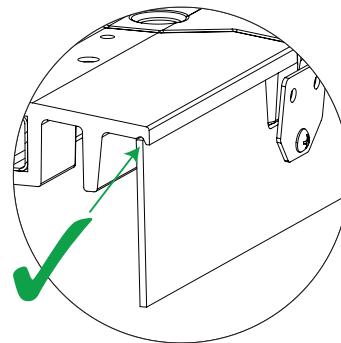
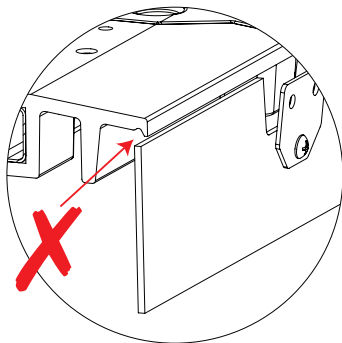

STEP 3

STEP 4: ATTACH GUTTER ANGLE

- Once you have ensured that the gutter angle is seated as high as it can be in the slot **BEHIND** the overhanging lip, use the remaining two screws to fasten the plate bracket to the tabs on the panels. These are self-tapping; no pilot holes are required.
- Tighten the four outbound screws and nuts just until snug.
- Double check for any gaps or bowing.
- You're done!

STEP 4

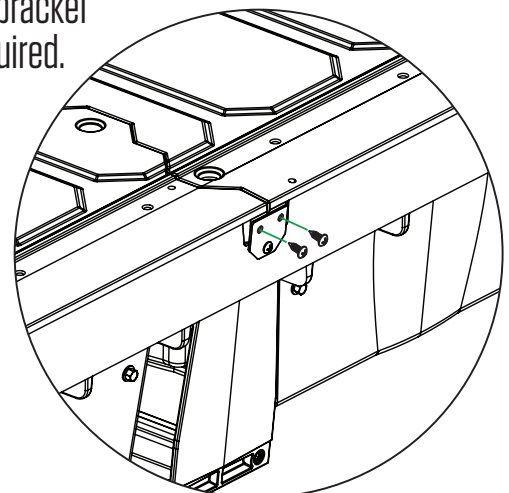

QUESTIONS? CALL US AT 208.806.0251

DECKED 3-YEAR LIMITED WARRANTY

(a.k.a. LEGAL MUMBO JUMBO)

DECKED LLC warrants to the original purchaser of this product that the product will be free from manufacturing defects in workmanship and materials for a period of three (3) years from the date of the original purchase. If within three (3) years from the original date of purchase this product fails due to defect in materials or workmanship, DECKED LLC will replace any defective part at its option.

The original purchaser must contact the DECKED LLC customer service team and provide a description of the defective part, including digital pictures if requested, with the original purchase documentation as validation of warranty coverage or have previously activated their warranty online.

This warranty DOES NOT cover or apply to:

- Damage to the product due to misuse, mishandling and abuse.
- Products not used in accordance with the manufacturer's instructions or recommendations.
- Product not assembled or installed according to manufacturer's instructions.
- Normal wear and tear.
- Undeclared damage to the system during shipping, acts of God. In addition, consequential damage and incidental damages (including lost time) such as damage to persons or property are not covered under this warranty.

REGISTER YOUR PRODUCT FOR ANY FUTURE WARRANTY NEEDS. [**DECKED.COM/REGISTER**](https://www.decked.com/register)