

22mm XW E-Stops

Key features:

- The depth behind the panel is only 48.7 mm for 1 to 4 contacts (with terminal cover) for illuminated and non-illuminated units.
- IDEC's original "Safe break action" ensures that the NC contacts open when the contact block is detached from the operator.
- 1 to 4NC main contacts and 1 or 2NO monitor contacts
- Push-to-lock, Pull or Turn-to-reset operator
- Safety lock mechanism (IEC60947-5-5, 6.2)
- Degree of protection IP65 (IEC60529)
- Fingersafe (IP20) terminals
- Two button sizes: $\phi 40$ and $\phi 60$ mm
- Push-ON illumination type available (40mm mushroom head)
- Direct opening action mechanism (IEC60947-5-5, 5.2, IEC60947-5-1, Annex K)
- RoHS compliant (EU directive 2002/95/EC).
- UL c-UL listed. EN compliant
- UL NISD category emergency stop device (File #E305148)



UL File #E68961



CCC No. 2005010305150897



Specifications

Applicable Standards	IEC60947-5-1, EN60947-5-1, IEC60947-5-5, EN60947-5-5, UL508, CSA C22.2 No. 14
Operating Temperature	Non-illuminated: -25 to +60°C (no freezing), Illuminated: -25 to +55°C (no freezing)
Operating Humidity	45 to 85% RH (no condensation)
Storage Temperature	-45 to +80°C
Operating Force	Push-to-lock: 32N Pull-to-reset: 21N Turn-to-reset: 0.27N·m
Minimum Force Required for Direct Opening Action	80N
Min Operator Stroke Required for Direct Opening Action	4mm
Maximum Operator Stroke	4.5mm
Contact Resistance	50mΩ maximum (initial value)
Contact Material	Gold plated silver
Insulation Resistance	100MΩ minimum (500V DC megger)
Impulse Withstand Voltage	2.5kV
Pollution Degree	3
Operation Frequency	900 operations/hour
Shock Resistance	Operating extremes: 150m/s ² (15G), Damage limits: 1000m/s ² (100G)
Vibration Resistance	Operating extremes: 10 to 500Hz, amplitude 0.35mm acceleration 50m/s ² Damage limits: 10 to 500Hz, amplitude 0.35mm acceleration 50m/s ²
Mechanical Life	250,000 operations minimum
Electrical Life	100,000 operations minimum, (250,000 operations minimum @ 24V AC/DC, 100mA)
Degree of Protection	Operator: IP65 (IEC60529) Terminal: IP20 (when XW9Z-VL2MF is installed)
Terminal Style	M3.0 screw terminal
Recommended Tightening Torque for Locking Ring	2.0N·m
Wire Size	16 AWG max
Weight	$\phi 40$ mm: 72g $\phi 60$ mm: 81g

Part Numbers

Overview



X Series E-Stops

Door Interlock Switches

Enabling Switches

Barriers

AS-Interface Safety at Work

Illumination	Operator Type	Monitor Contact	Main Contact	Part Number	
Non-Illuminated 	40mm Mushroom	1NO	1NC	XW1E-BV411M-R	
		–	2NC	XW1E-BV402M-R	
		2NO	2NC	XW1E-BV422M-R	
		1NO	3NC	XW1E-BV413M-R	
		–	4NC	XW1E-BV404M-R	
		60mm Mushroom	1NO	1NC	XW1E-BV511M-R
			–	2NC	XW1E-BV502M-R
			2NO	2NC	XW1E-BV522M-R
			1NO	3NC	XW1E-BV513M-R
			–	4NC	XW1E-BV504M-R
Illuminated ¹ 	40mm Mushroom LED with built-in 24V AC/DC LED	1NO	1NC	XW1E-LV411Q4M-R	
		–	2NC	XW1E-LV402Q4M-R	
		2NO	2NC	XW1E-LV422Q4M-R	
		1NO	3NC	XW1E-LV413Q4M-R	
		–	4NC	XW1E-LV404Q4M-R	
	40mm Mushroom Push-ON LED ²	1NO	2NC	XW1E-TV412Q4M-R	



1. The light is independent of the position of the switch, except for push-on LED type.
2. The light only operates when the switch is pressed (as it is internally wired).

Contact Ratings

Rated Insulation Voltage (Ui)		250V				
Current (Ith)		5A				
Rated Operating Voltage (Ue)		30V	125V	250V		
Rated Operating Current	Main Contacts (NC)	AC 50/60Hz	Resistive Load (AC-12)	–	5A	3A
			Inductive Load (AC-15)	–	3A	1.5A
	DC	Resistive Load (DC-12)	2A	0.4A	0.2A	
		Inductive Load (DC-13)	1A	0.22A	0.1A	
Monitor Contacts (NO)	AC 50/60Hz	Resistive Load (AC-12)	–	1.2A	0.6A	
		Inductive Load (AC-14)	–	0.6A	0.3A	
	DC	Resistive Load (DC-12)	2A	0.4A	0.2A	
		Inductive Load (DC-13)	1A	0.22A	0.1A	



Minimum applicable load: 5V AC/DC, 1mA (reference value).
The rated operating currents are measured at resistive/inductive load types specified in IEC 60947-5-1.

Mounting Hole Layout

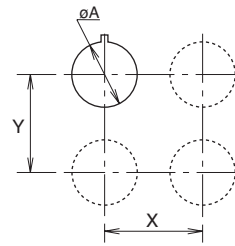

Measurements

Size	øA	X & Y
40mm	22.3 ^{+0.4}	70mm min

Panel Cutout

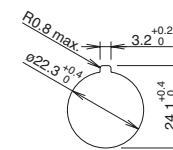

Part Numbers Key

XW1E - L V 4 11 Q4M - R

Illumination

- B: Non-Illuminated
- L: Illuminated LED
- T: Illuminated Push-ON LED

Mushroom Size

- 4: ø40mm
- 5: ø60mm (non-illuminated only)

Contact Configuration

- 11: 1NO - 1NC
- 02: 2NC
- 13: 1NO - 3NC
- 04: 4NC
- 22: 2NO-2NC
- 12: 1NO-2NC (Push-ON LED only)

Voltage Code

- Blank: Non-illuminated
- Q4: Illuminated 24V AC/DC

Illuminated Unit LED Ratings

Operating Voltage	Current
24V AC/DC ±10%	15mA

Depth Behind the Panel

Depth (mm)	Description
48.7	1 - 4 contacts, both illuminated and non-illuminated

Terminal Arrangements (Bottom View)

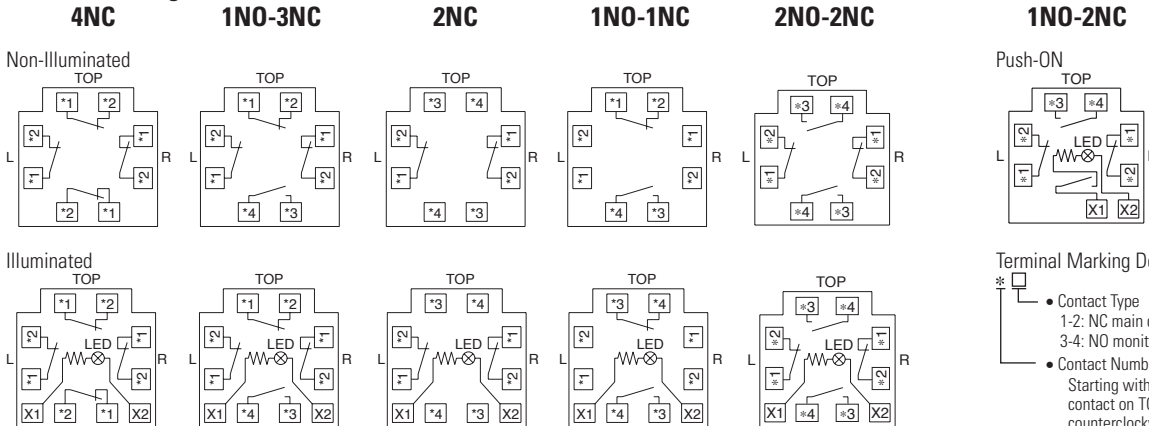

Terminal Marking Description

- Contact Type
 - 1-2: NC main contact
 - 3-4: NO monitor contact
- Contact Number (1-4)
 - Starting with the contact on TOP in a counterclockwise direction.
 - Note:
 - 1: contact on the TOP
 - 2: contact on the Left
 - 3: contact on the Bottom
 - 4: contact on the Right

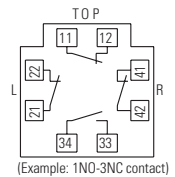

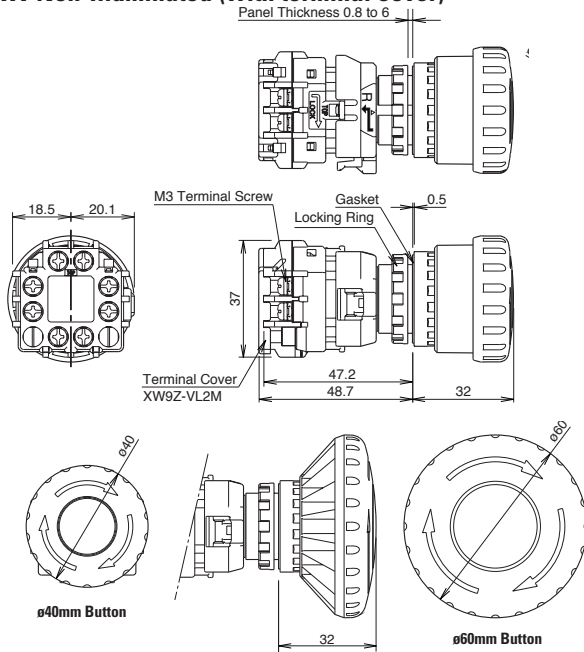
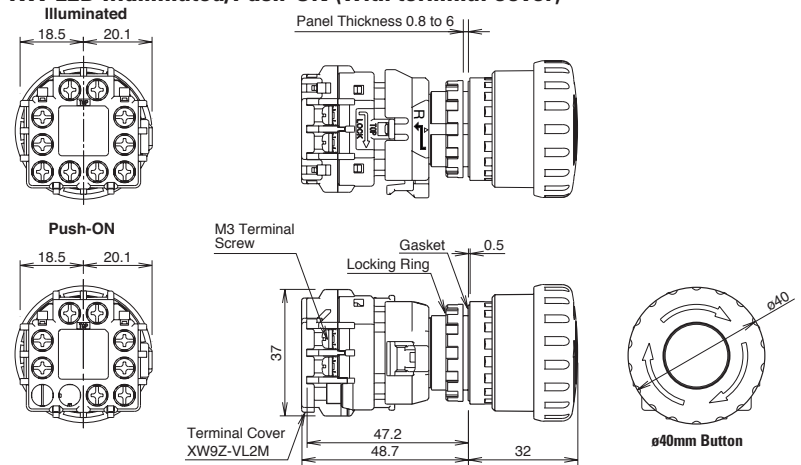
Dimensions (mm)
XW Non-Illuminated (with terminal cover)

XW LED Illuminated/Push-ON (with terminal cover)

Accessories: Terminal Covers

Model	Description	Part Numbers
	Terminal Cover for contact block	XW9Z-VL2M
	IP20 Fingersafe Cover	XW9Z-VL2MF

Accessories: Shrouds

	Part Numbers	E-Stop Types	Applicable Standards
	HW9Z-KG1	40mm Mushroom Head	SEMI S2-0703, 12.5.1 Compliant
	HW9Z-KG2	40mm, and 60mm Mushroom Head	SEMI S2-0703, 12.5.1 & SEMATECH Compliant
	HW9Z-KG3	40mm Mushroom Head	SEMI S2 Compliant (Approved by TUV)
	HW9Z-KG4	40mm Mushroom Head	SEMI S2 Compliant (Approved by TUV) & SEMATECH

Accessories: Nameplates

	Size and Style	Part Number	Inner Ø	Outer Ø
	22mm Blank ø60mm	HWAV-0	22mm	60mm
	22mm "Emergency Stop" ø60mm	HWAV-27	22mm	60mm
	22mm "Emergency Stop" ø80mm	HWAV5-0	22mm	80mm
	22mm blank ø80mm	HWAV5-27	22mm	80mm



Use 60mm nameplates for 40mm mushroom buttons and 80mm nameplates for 60mm mushroom buttons.

Operating Instructions

Removing the Contact Block

First unlock the operator button. Grab the bayonet ring ① and pull back the bayonet ring until the latch pin clicks ②, then turn the contact block counterclockwise and pull out ③.

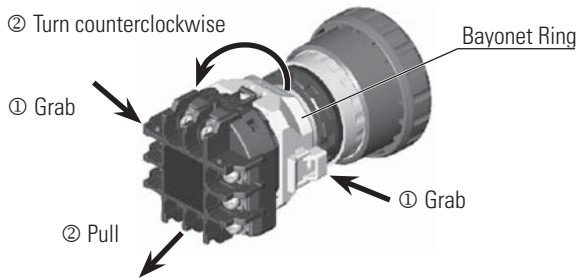

Notes for removing the contact block

1. When the contact block is removed, the monitor contact (NO contact) is closed.
2. While removing the contact block, do not exert excessive force, otherwise the switch may be damaged.
3. An LED lamp is built into the contact block for illuminated pushbuttons. When removing the contact block, pull the contact block straight to prevent damage to the LED lamp. If excessive force is exerted, the LED lamp may be damaged and fail to light.

Panel Mounting

Remove the locking ring from the operator and check that the rubber gasket is in place. Insert the operator from panel front into the panel hole. Face the side without thread on the operator with TOP marking upward, and tighten the locking ring using ring wrench MW9Z-T1 to a torque of 2.0 N·m maximum.

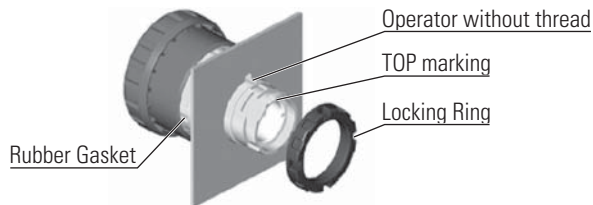

Notes for Panel Mounting

To prevent the XW emergency stop switch from rotating when resetting from the latched position, use of an anti-rotation ring (HW9Z-RL) or a nameplate is recommended.

Installing the Contact Block

First unlock the operator button. Align the small t marking on the edge of the operator with the small s marking on the yellow bayonet ring. Hold the contact block, not the bayonet ring. Press the contact block onto the operator and turn the contact block clockwise until the bayonet ring clicks.

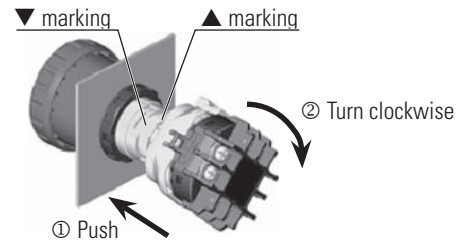

Notes for installing the contact block

Make sure that the bayonet ring is in the locked position. Check that the two projections on the bayonet ring are securely in place.

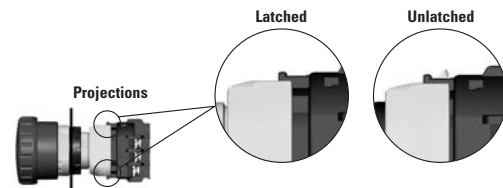

Wiring

The applicable wire size is 16 AWG maximum.

Operating Instructions, continued

Screw Terminal

1. Wire thickness: AWG18 to 16
2. Tighten the M3 terminal screw to a tightening torque of 0.6 to 1.0 N·m.

Installing and Removing Terminal Covers

XW9Z-VL2M

To install the terminal cover, align the TOP marking on the terminal cover with the TOP marking on the contact block. Place the two projections on the bottom side of the contact block into the slots in the terminal cover. Press the terminal cover toward the contact block.

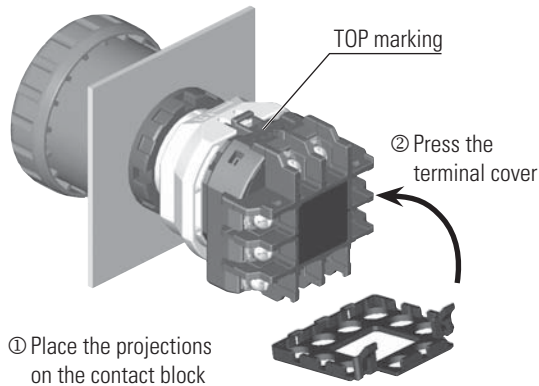

To remove the terminal cover, pull out the two latches on the top side of the terminal cover. Do not exert excessive force to the latches, otherwise the latches may break.

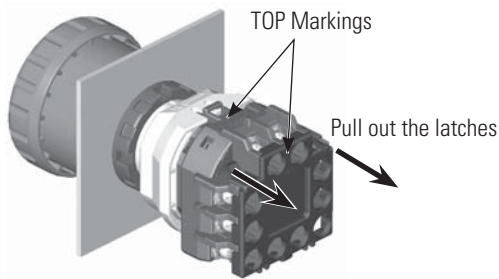

**IP20 Protection Terminal Cover
XW9Z-VL2MF**

To install the IP20 protection cover, align the TOP marking on the cover with the TOP marking on the contact block, and press the cover toward the contact block.

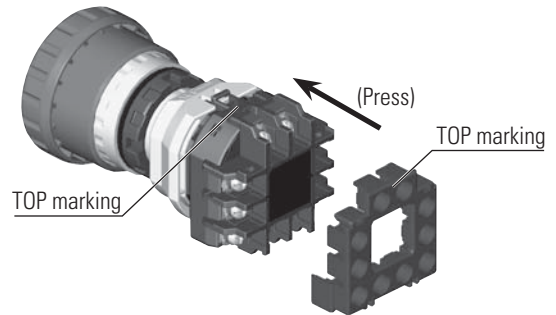

1. Once installed, the XW9Z-VL2MF cannot be removed.
2. The XW9Z-VL2MF cannot be installed after wiring.
3. With the XW9Z-VL2MF installed, crimping terminals cannot be used.
4. Make sure that the XW9Z-VL2MF is securely installed. IP20 protection cannot be achieved when installed loosely, and electric shocks may occur.

Contact Bounce

When the button is reset by pulling or turning, the NC main contacts will bounce. When pressing the button, the NO monitor contacts will bounce.

When designing a control circuit, take the contact bounce time into consideration (reference value: 20 ms).

LED Illuminated Switches

LED lamp is built into the contact block and cannot be replaced.

**Installing the Anti-rotation Ring
HW9Z-RL**

Align the side without thread on the operator with TOP marking, the small s marking on the anti-rotation ring, and the recess on the mounting panel.

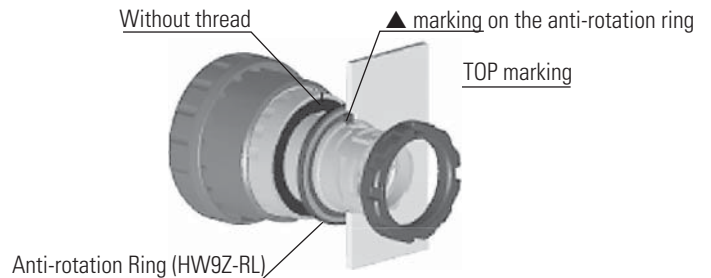

Overview

X Series E-Stops

Door Interlock Switches

Enabling Switches

Barriers

AS-Interface Safety at Work