

# REQUIRED TOOLS

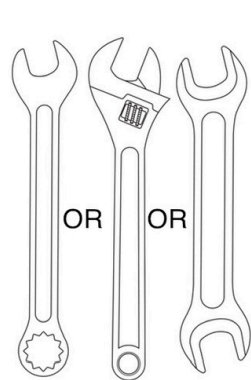

7 MM WRENCH



LONG NOSE PLIERS



2.5MM HEX KEY



3 MM HEX KEY



GLOVES  
NOT NECESSARY,  
WIFE MADE ME ADD IT

# VIDEO REFERENCE

SCAN QR CODE

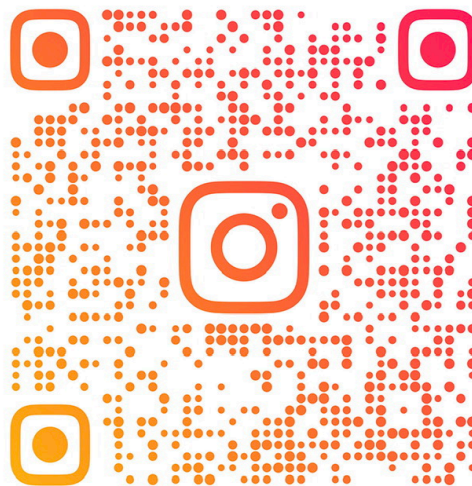

BASKET ASSEMBLY VIDEO

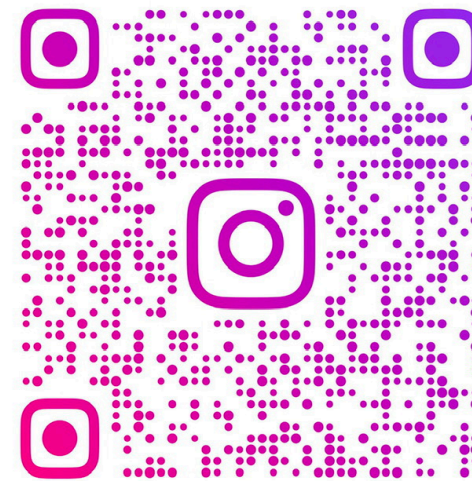

INSTALLATION VIDEO

PERIODICALLY CHECK AND TIGHTEN YOUR HARDWARE.  
PLEASE FOLLOW AND TAG US ON FACEBOOK AND INSTAGRAM  
@IRVLABS



1/4" RUBBER SPACERS

M5 BOLTS

LARGE WASHERS

M4 BOLTS (A)  
(2.5 MM HEX)

SMALL WASHERS (B)

M4 ACORN NUT (C)  
(7MM WRENCH / SOCKET)

# PARTS

# ASSEMBLY DIAGRAM

## LOW VERSION

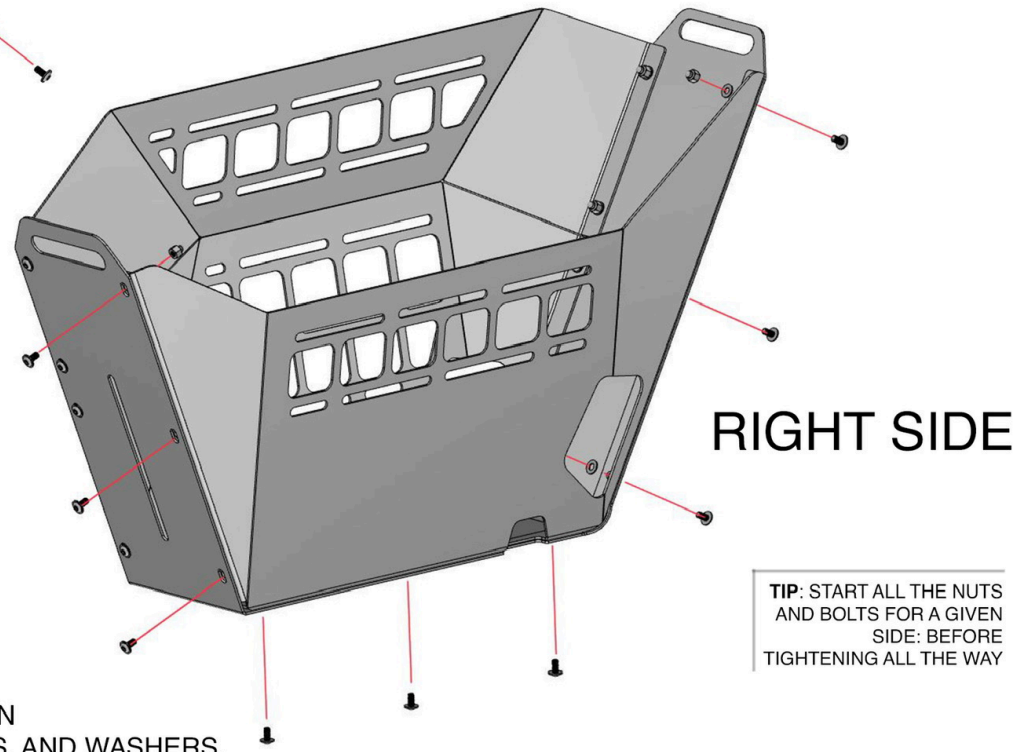
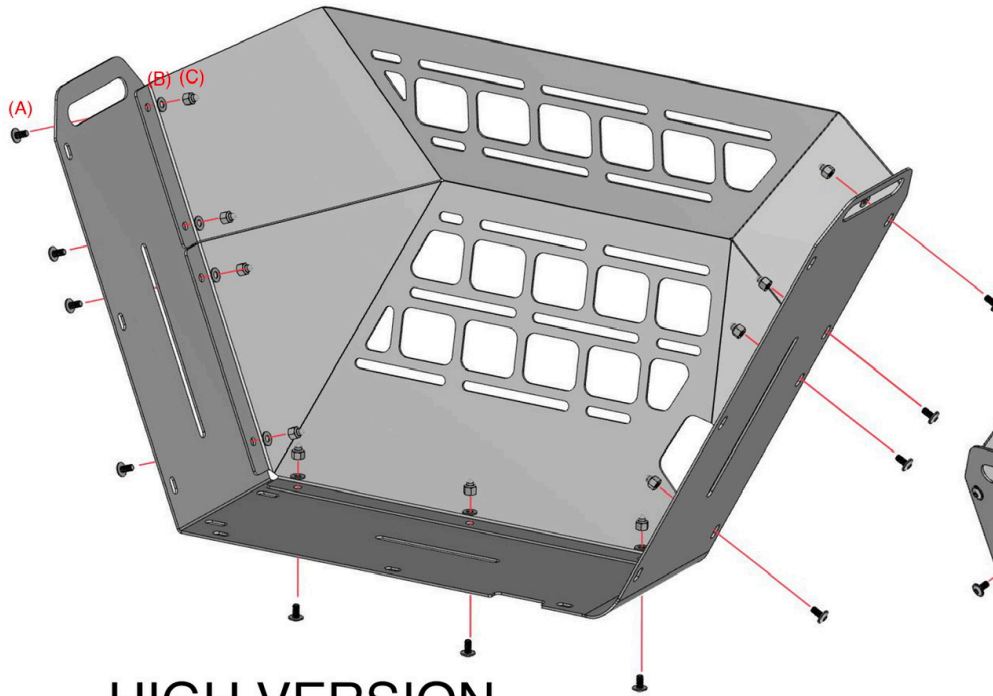
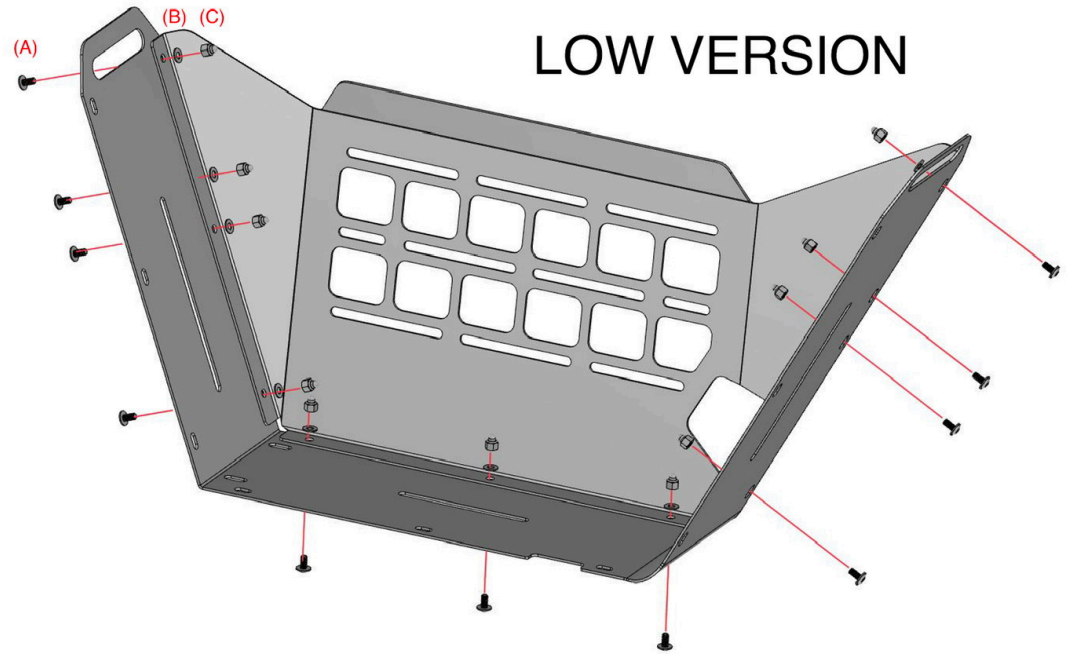

## HIGH VERSION

## RIGHT SIDE

**1** OPEN THE PARTS BAG AND IDENTIFY / GROUP THE HARDWARE. SEE DIAGRAM FOR PROPER INSTALLATION. SOME EXTRA PARTS MAY BE INCLUDED

**2** ASSEMBLE THE BASKET AS SHOWN ON THE DIAGRAM. IT HELPS TO ALIGN THE TOP CORNERS OF THE BASKET THEN WORK YOUR WAY DOWN FASTENING THE SCREWS, BOLTS, AND WASHERS.

**TIP:** START ALL THE NUTS AND BOLTS FOR A GIVEN SIDE: BEFORE TIGHTENING ALL THE WAY

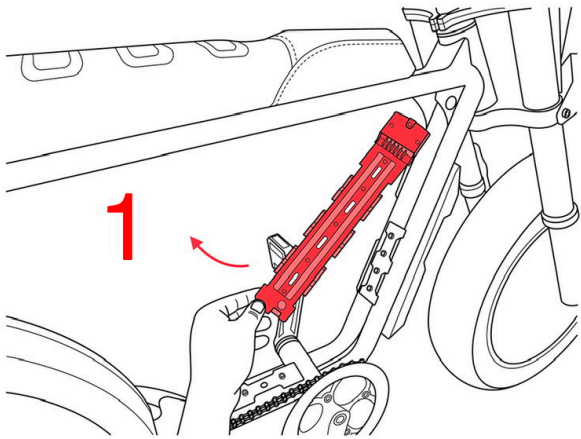

IF THE BIKE IS EQUIPPED WITH A BATTERY TRAY, REMOVE THIS NOW.

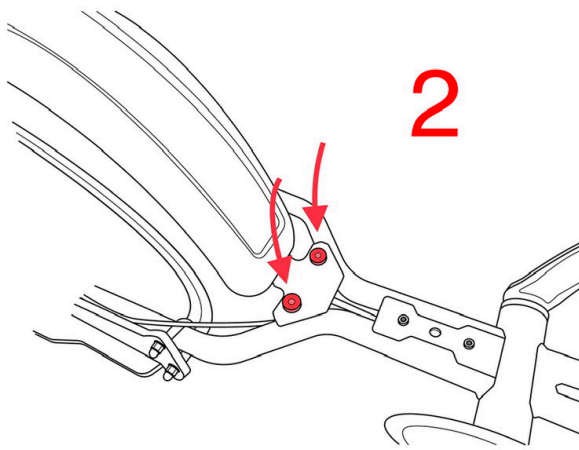

PLACE TWO RUBBER SPACERS ABOVE THE REAR MOUNTING POINTS OF THE FRAME.

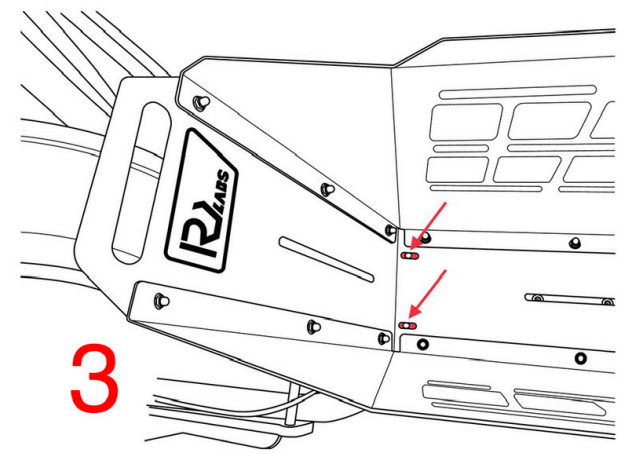

CAREFULLY PLACE THE BASKET ON TOP, LINING UP THE CORRESPONDING MOUNTING POINTS AND RUBBER WASHERS.

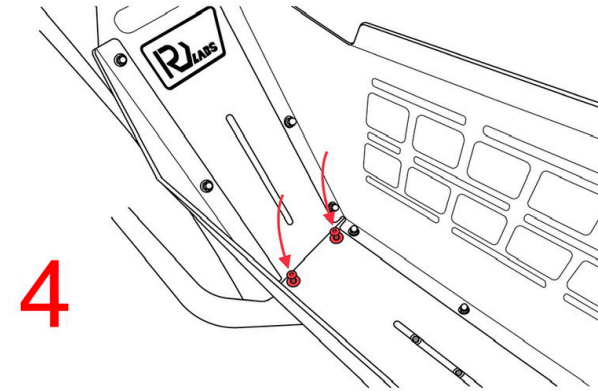

INSERT TWO M5 BOLTS, TWO LARGE WASHERS AND THREAD IN. **DO NOT TIGHTEN ALL THE WAY.**

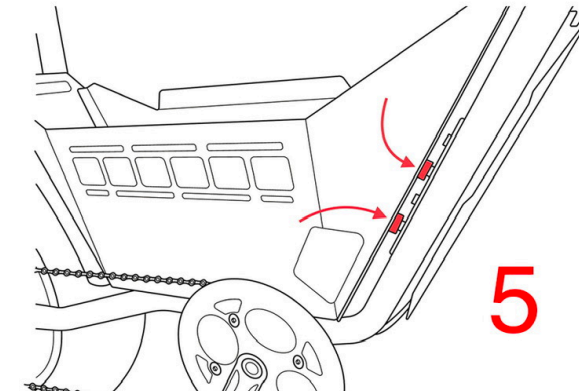

USING THE PLIERS, HOLD TWO RUBBER SPACERS IN BETWEEN THE FRONT OF THE BASKET AND DOWN TUBE.

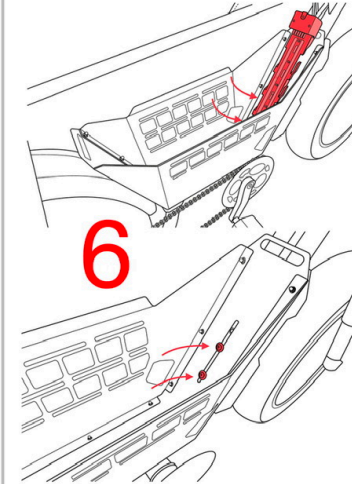

IF EQUIPPED WITH A BATTERY TRAY, RE-INSTALL THE TRAY USING TWO M5 BOLTS.

**OR** ⇕

WITHOUT A BATTERY TRAY; USE TWO M5 BOLTS AND TWO LARGE WASHERS TO SECURE THE FRONT BASKET.

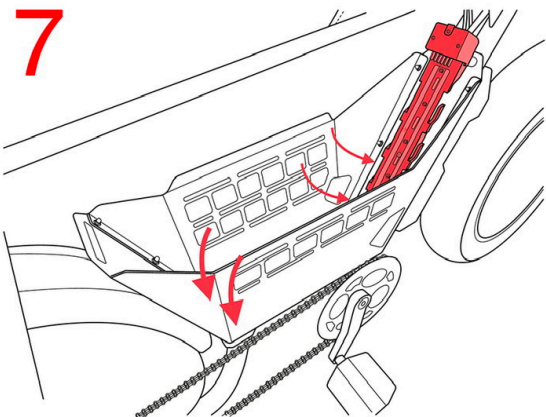

LASTLY, TORQUE DOWN ALL BOLTS AND SECURE THE BASKET.

MAKE SURE THE BATTERY TRAY IS TORQUED DOWN EVENLY TO ENSURE PROPER FUNCTION.

BE SURE THAT THE KEY AREA HAS PLENTY OF ROOM TO FUNCTION PROPERLY BEFORE LOCKING IN YOUR BATTERY.

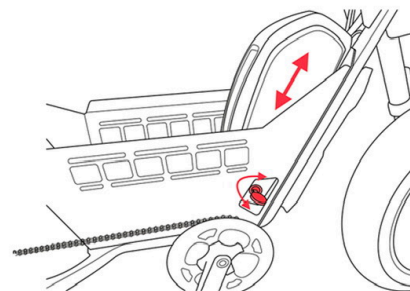

### TIPS

SECURE YOUR CARGO WITH THE INCLUDED SHOCK CORD. DO NOT CARRY LOSE ITEMS IN THE BASKET.

