

2866801COM Bar Cabinet

**NOV
OGR
ATZ**

Date of Purchase ___ / ___ / ___
Lot Number:

B342866801COM00KX

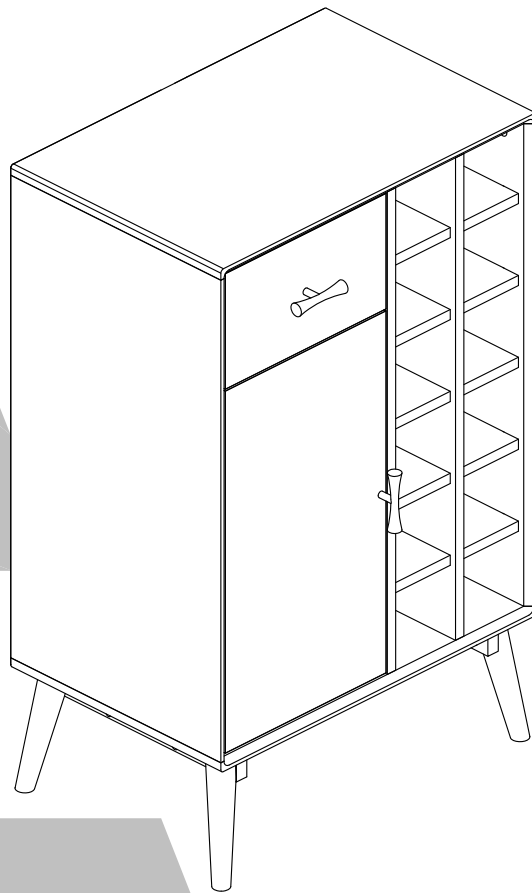

THIS INSTRUCTION BOOKLET CONTAINS **IMPORTANT** SAFETY INFORMATION. PLEASE READ AND KEEP FOR FUTURE REFERENCE.

Do Not Return This Product!

Contact our customer service team for help first.

Call: 1-800-489-3351 (toll free)

Monday-Friday 9am - 5pm CST

Visit: www.ameriwoodhome.com

WARNING

- Unit can tip over causing severe injury or death.
- Anchor unit to stud in wall (if instructed to).
- Do Not allow children to climb on unit.
- Put heavy items on lower shelves or drawers.

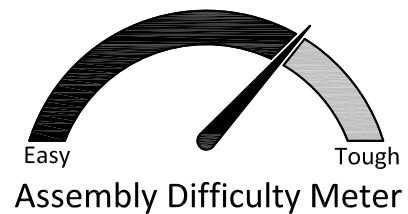

Follow Ameriwood Home



Contact Us!

Do NOT return this product!

Contact our friendly customer service team first for help.

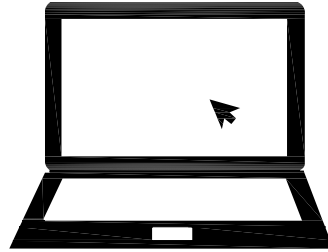
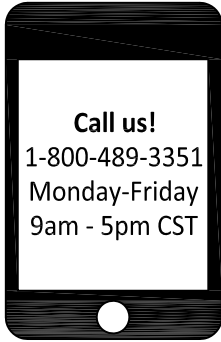

Visit ameriwoodhome.com

Assembly Tips



PEOPLE NEEDED FOR ASSEMBLY: 2
ESTIMATED ASSEMBLY TIME: 1 HOUR

- Open your item in the area you plan to keep it to avoid excessive heavy lifting.
- Identify, sort and count the parts before attempting assembly.
- Compression dowels are lightly tapped in with a hammer.
- Slides are labeled with a **R** (right) and **L** (left) for proper placement.
- Make sure to always face the point on the top of the Cam Lock towards the outer edge.
- Use all the nails provided for the back panel and spread them out equally.
- Back panel must be used to make sure your unit is sturdy.
- Do NOT use harsh chemicals or abrasive cleaners on this item.
- Never push, pull, or drag your furniture.

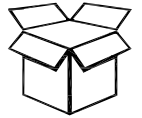

Before You Start

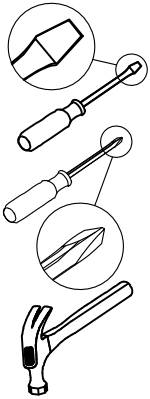
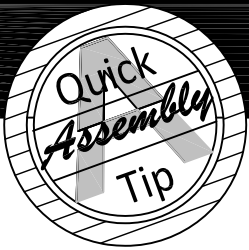

- ✓ Read through each step carefully and follow the proper order
- ✓ Separate and count all your parts and hardware
- ✓ Give yourself enough room for the assembly process
- ✓ Have the following tools: Flat Head Screwdriver, #2 Phillips Head Screwdriver and Hammer
- ✓ Caution: If using a power drill or power screwdriver for screwing, please be aware to slow down and stop when screw is tight. Failure to do so may result in stripping the screw.

Cam Lock Fastening System

This Cam Lock Fastening System will be used throughout the assembly process.

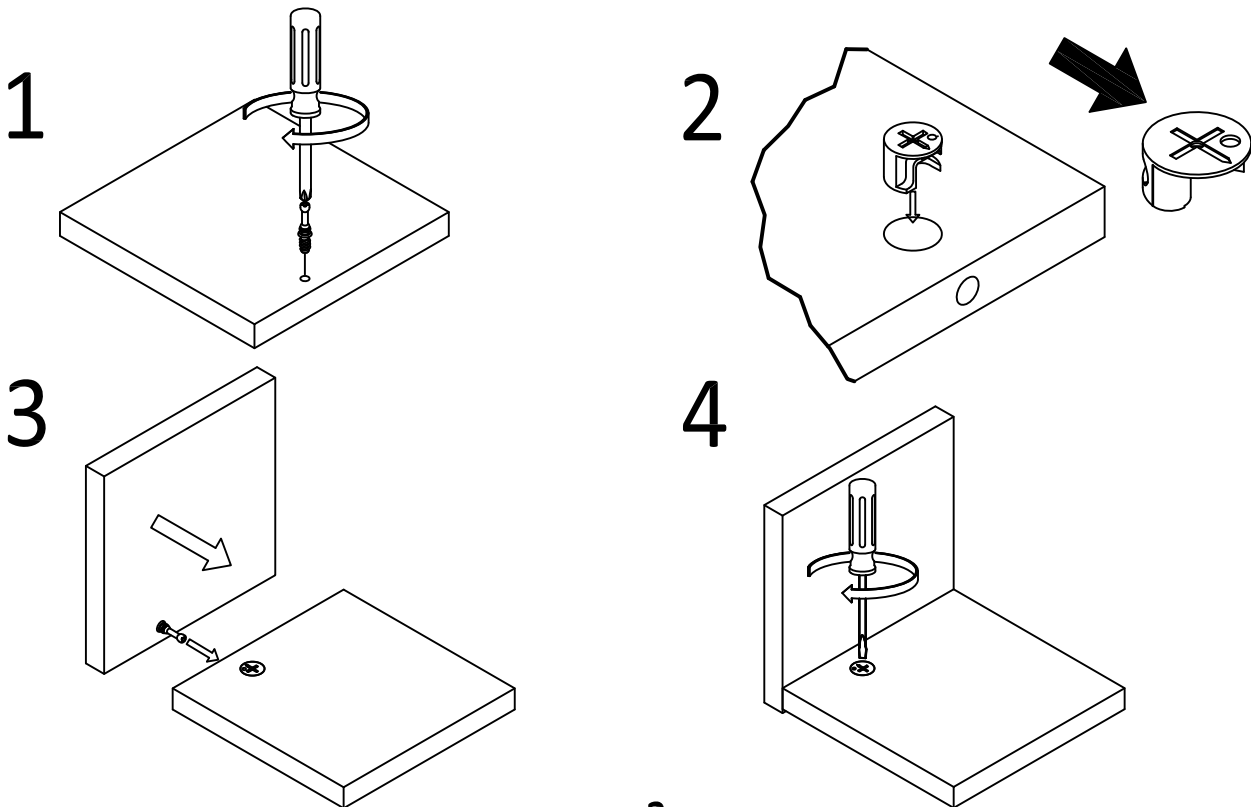

Board Identification

Not Actual Size

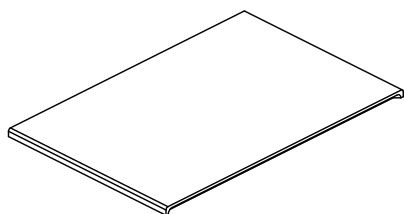

A

Top panel
T2866801010KX

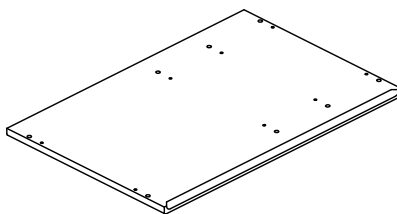

B

Bottom panel
T2866801020KX

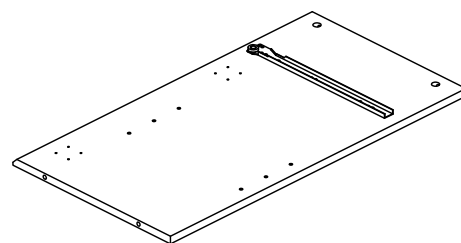

C

Left side panel
T2866801030KX

Preassembled parts	
Left side panel	T2866801031KX
Left slide track	TKX1027-2
Screw Ø3*12 (3)	TKX1016

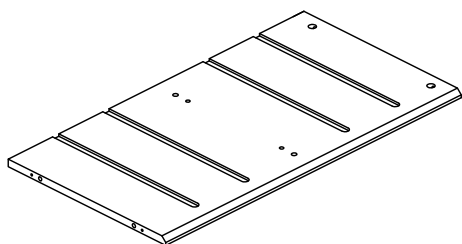

D

Right side panel
T2866801040KX

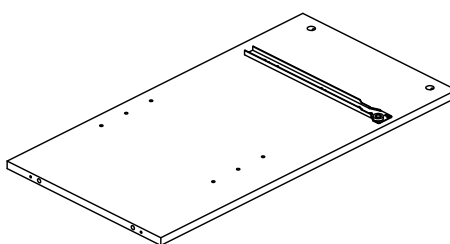

E

Partition
T2866801050KX

Preassembled parts	
Partition	T2866801051KX
Right slide track	TKX1028-2
Screw Ø3*12 (3)	TKX1016

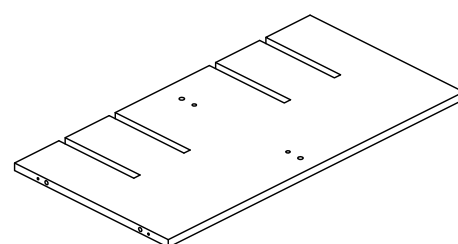

F

Divider
T2866801060KX

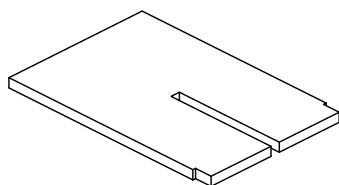

G

Wine shelf
T2866801070KX
QTY:4PCS

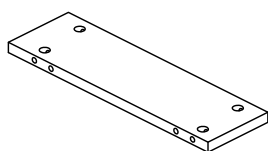

H

Fixed shelf
T2866801080KX

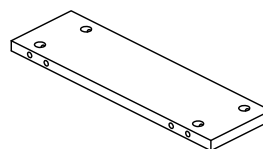

I

Fixed shelf
T2866801090KX

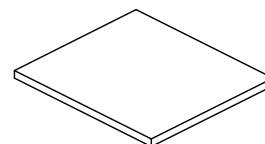

J

Adjustable shelf
T2866801100KX

Board Identification

Not Actual Size

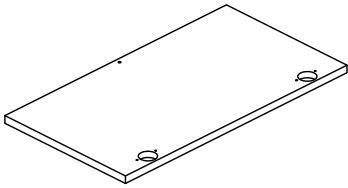

K

Door
T2866801110KX

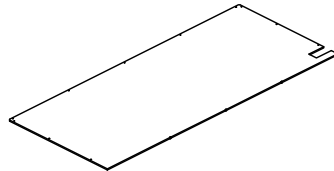

L

Left back panel
T2866801120KX

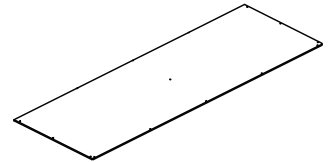

M

Right back panel
T2866801130KX

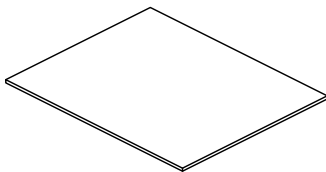

N

Drawer bottom
T2866801140KX

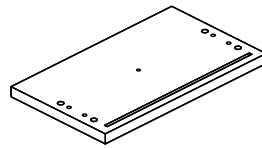

O

Drawer front
T2866801150KX

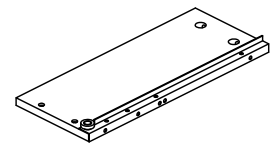

P

Left drawer side
T2866801160KX

Preassembled parts	
Left drawer side	T2866801161KX
Left slide runner	TKX1027-1
Screw Ø3*12 (3)	TKX1016

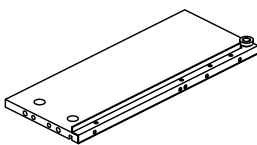

Q

Right drawer side
T2866801170KX

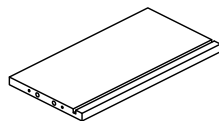

R

Drawer back
T2866801180KX

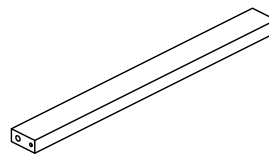

S

Bottom support
T2866801190KX
QTY:2PCS

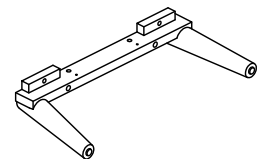

T

Leg frame
T2866801200KX
QTY:2PCS

Preassembled parts	
Right drawer side	T2866801171KX
Right slide runner	TKX1028-1
Screw Ø3*12 (3)	T KX1016

Preassembled parts	
Leg frame (2)	T2866801201KX
Tack glide Ø15 (4)	TKX1179

Board Identification

Not Actual Size

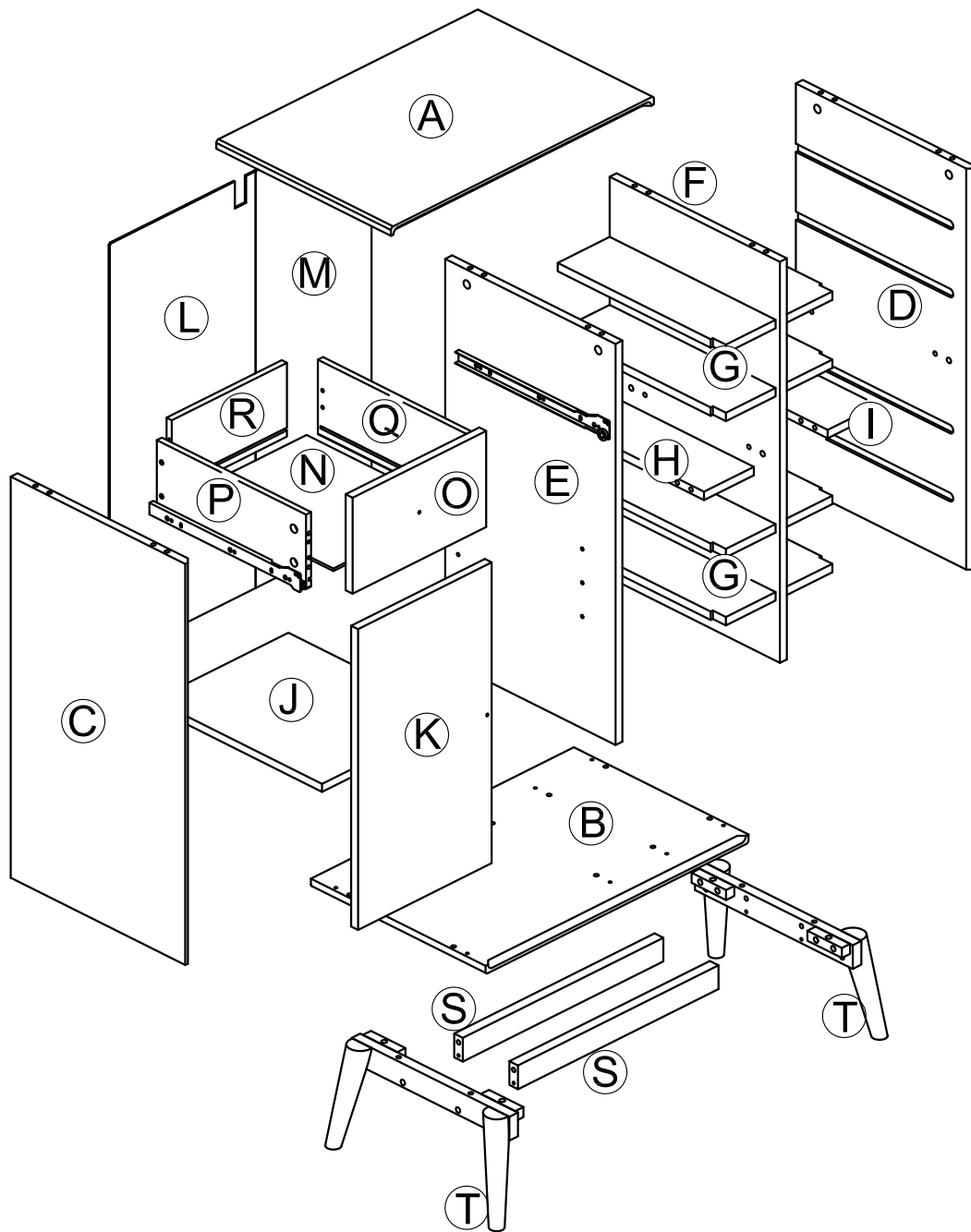

Part List

Actual Size

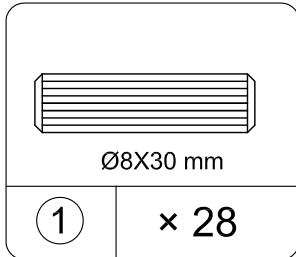

Wood dowel
TKX1005

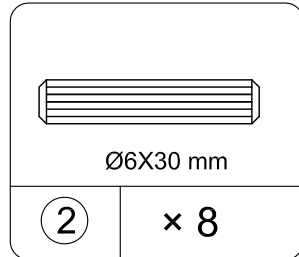

Wood dowel
TKX1006

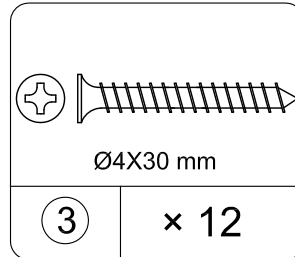

Screw
TKX1104

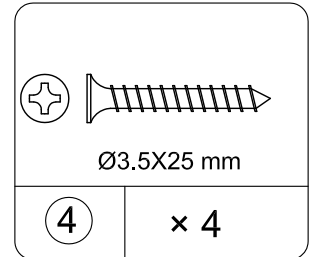

Screw
TKX1145

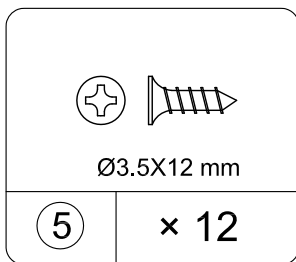

Screw
TKX1021

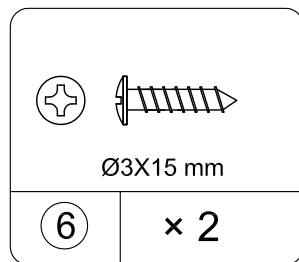

Screw
TKX1017

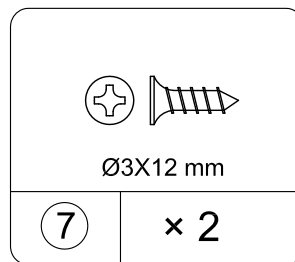

Screw
TKX1146

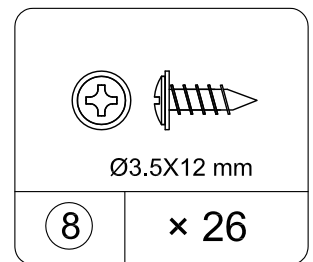

Screw
TKX1141

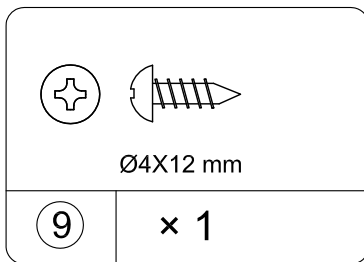

Screw
TKX1037

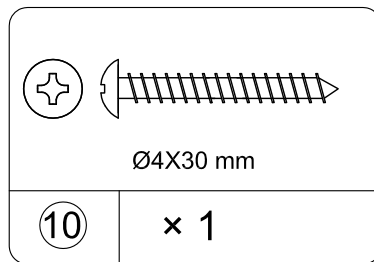

Screw
TKX1039

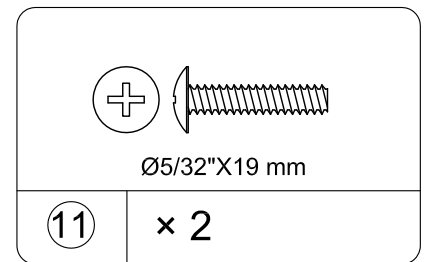

Screw bolt
TKX1049

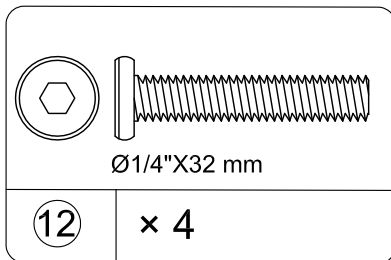

Bolt
TKX1009

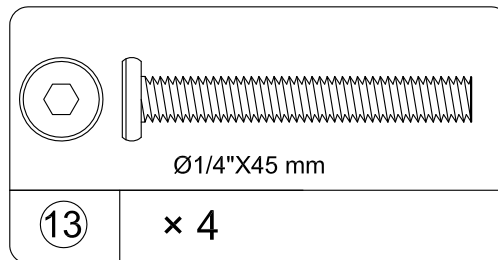

Bolt
TKX1149

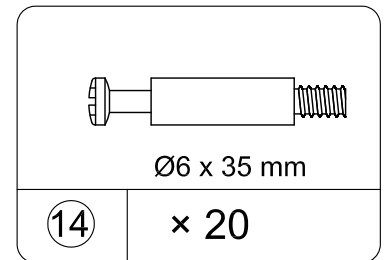

Cam bolt
TKX1012

Not Actual Size

Hardware Bag Reference Number:
22866801COM0KX

Not Actual Size

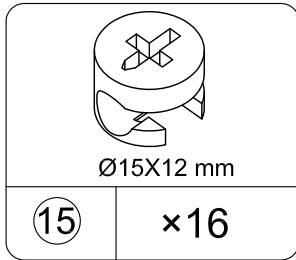

Cam lock
TKX1022

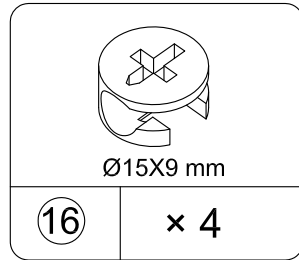

Cam lock
TKX1023

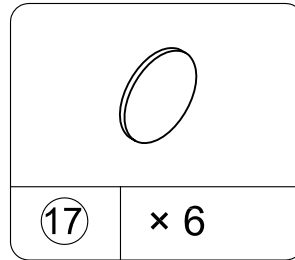

Cam cover
TKX1013

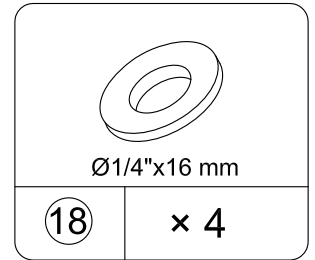

Washer
TKX1003

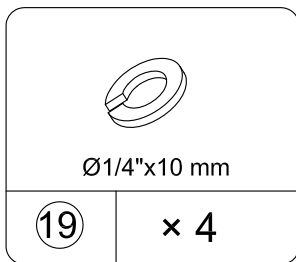

Spring washer
TKX1002

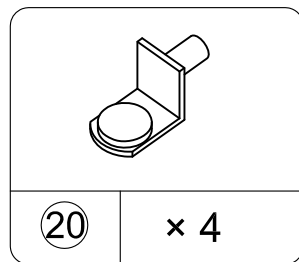

Shelf support
TKX1047

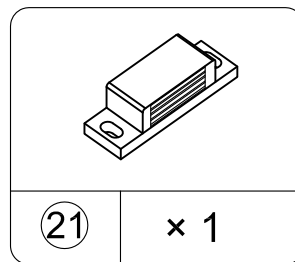

Magnetic catch
TKX1147

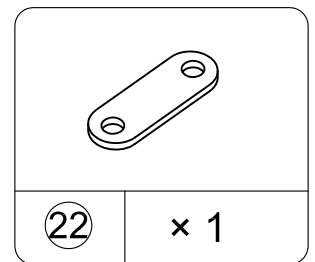

Metal plate
TKX1148

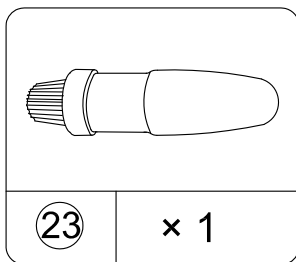

Glue
TKX1014

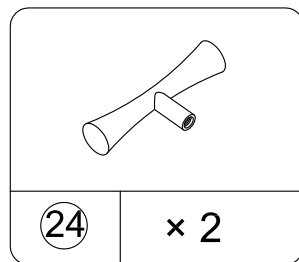

Handle
TKX1144

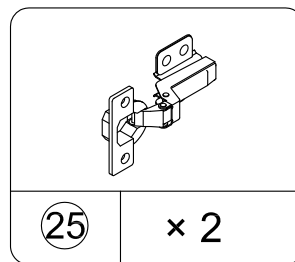

Euro hinge
TKX1084

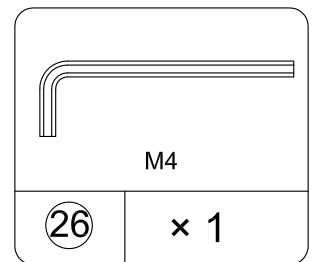

Hex key
TKX1004

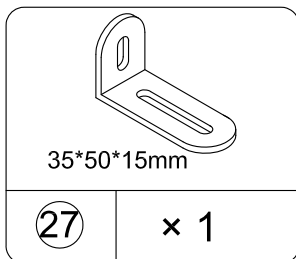

Wall bracket
TKX1026

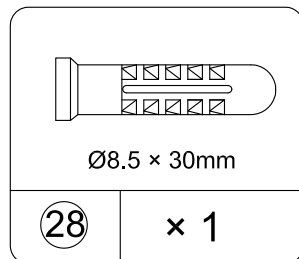

Wall anchor
TKX1042

STEP 2

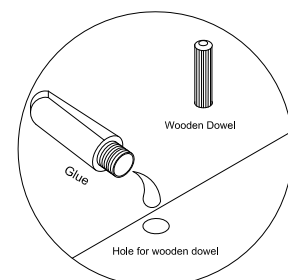
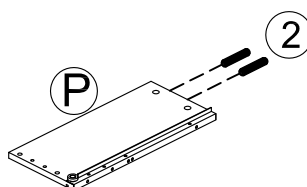
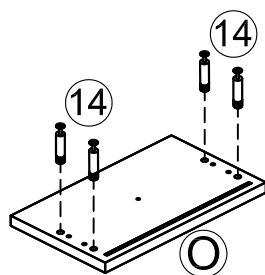
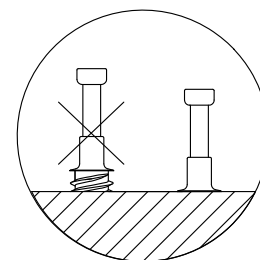
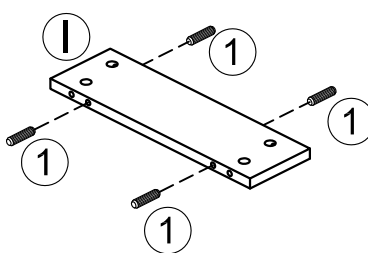
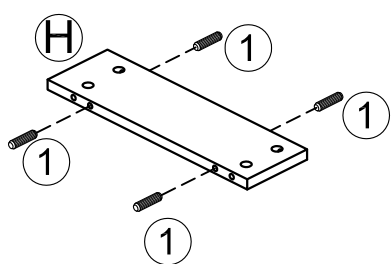
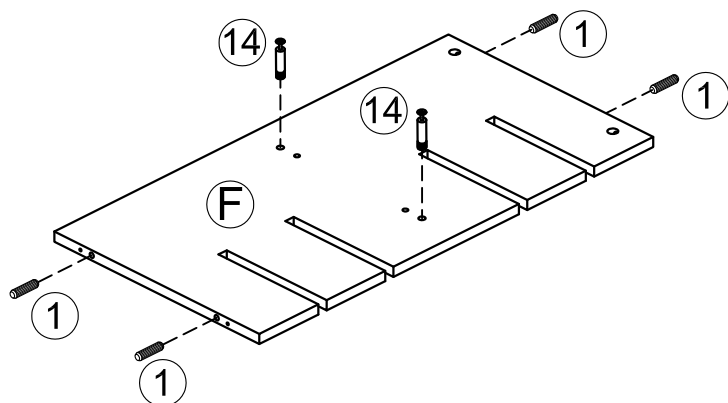
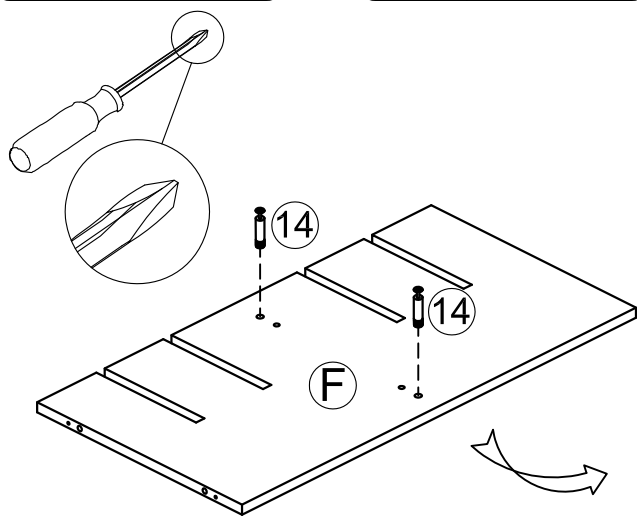
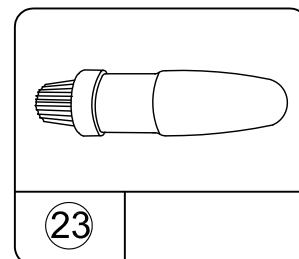
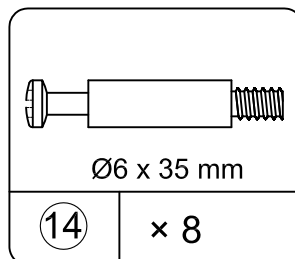
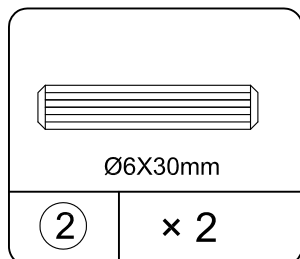
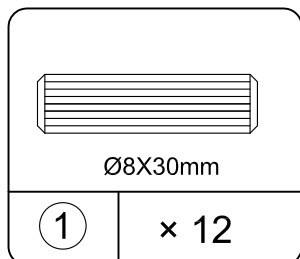

Use one drop of glue in dowel hole.

STEP 3

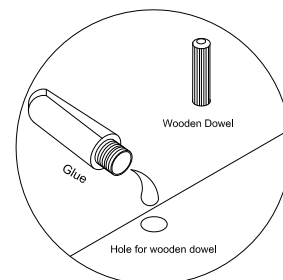
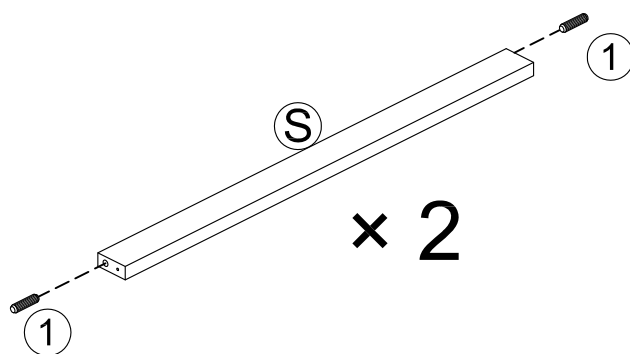
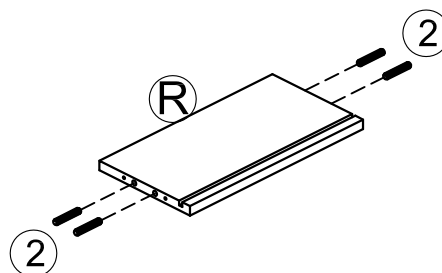
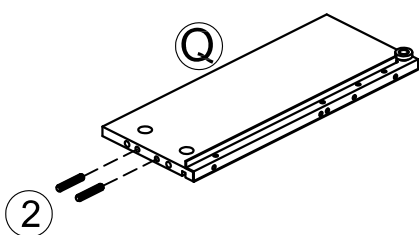
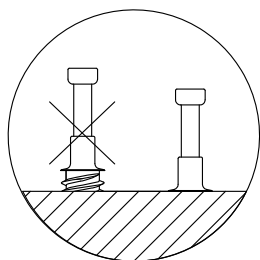
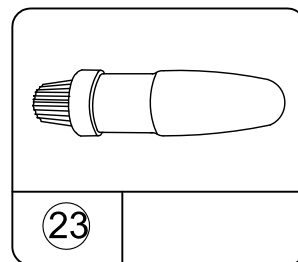
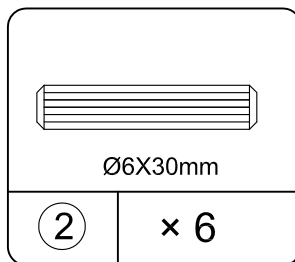
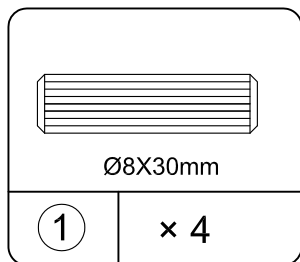
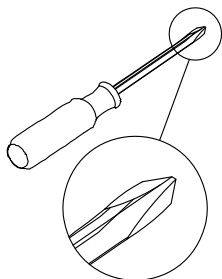

Use one drop of glue in dowel hole.

STEP 4

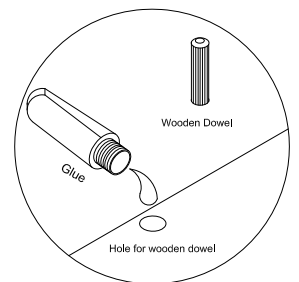
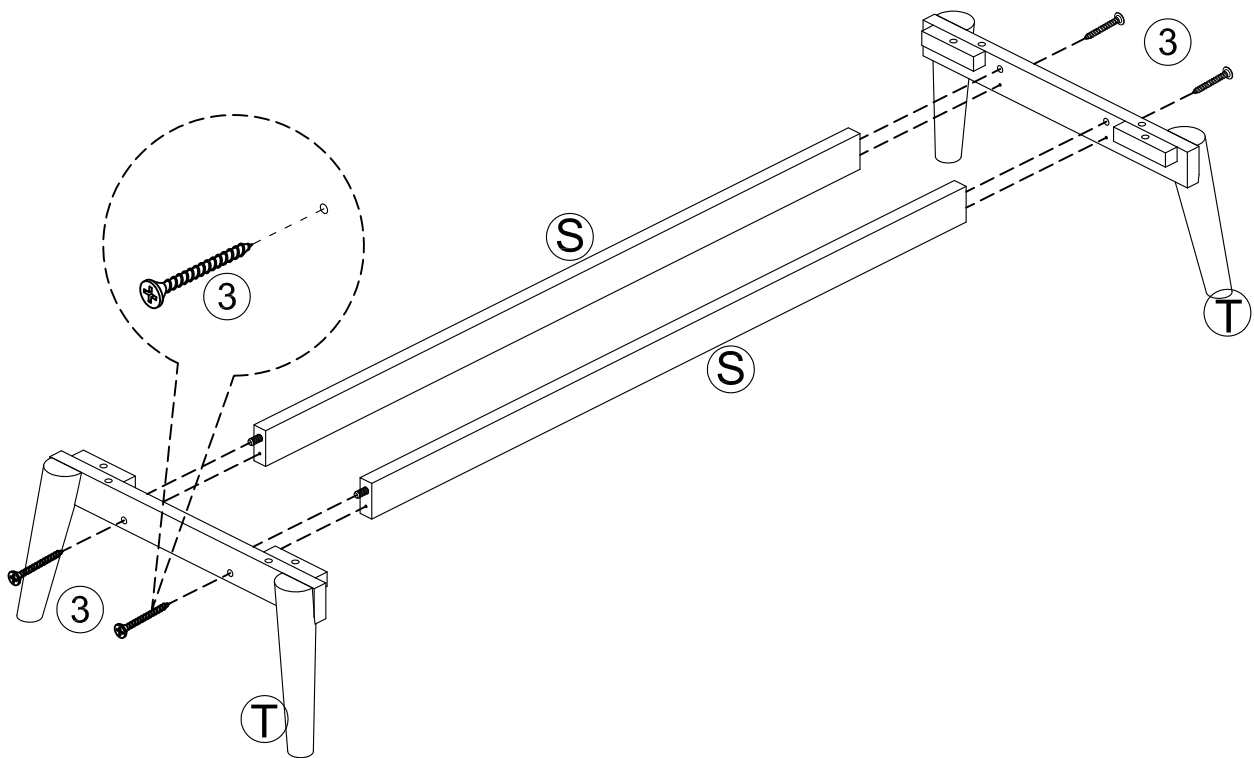
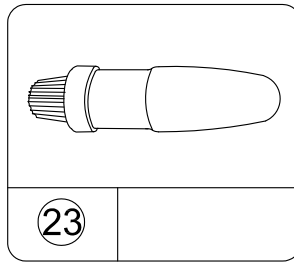
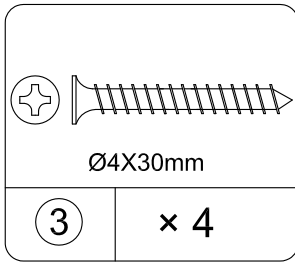
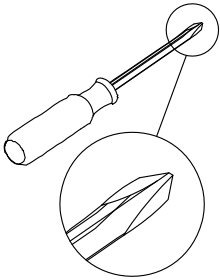

Use one drop of glue in dowel hole.

STEP 5

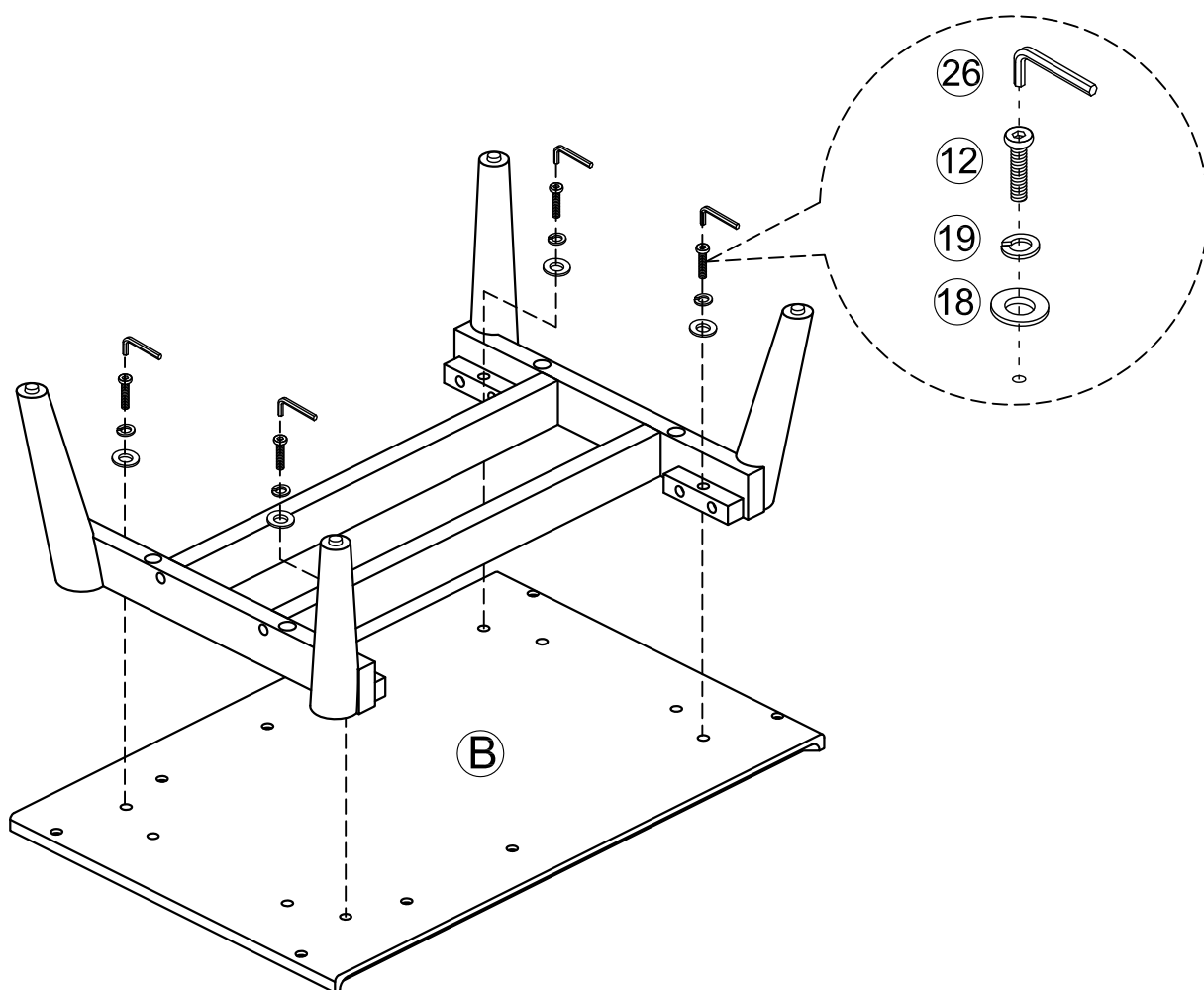
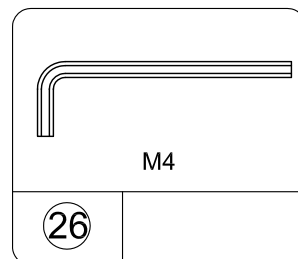
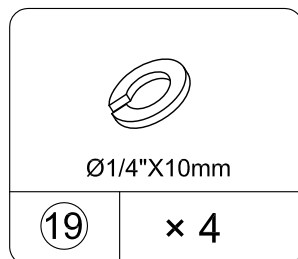
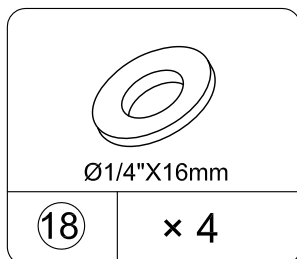
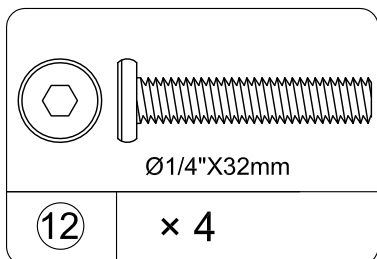

Note: DO NOT Tighten the bolt to ensure the assembly successfully in this step.

STEP 6

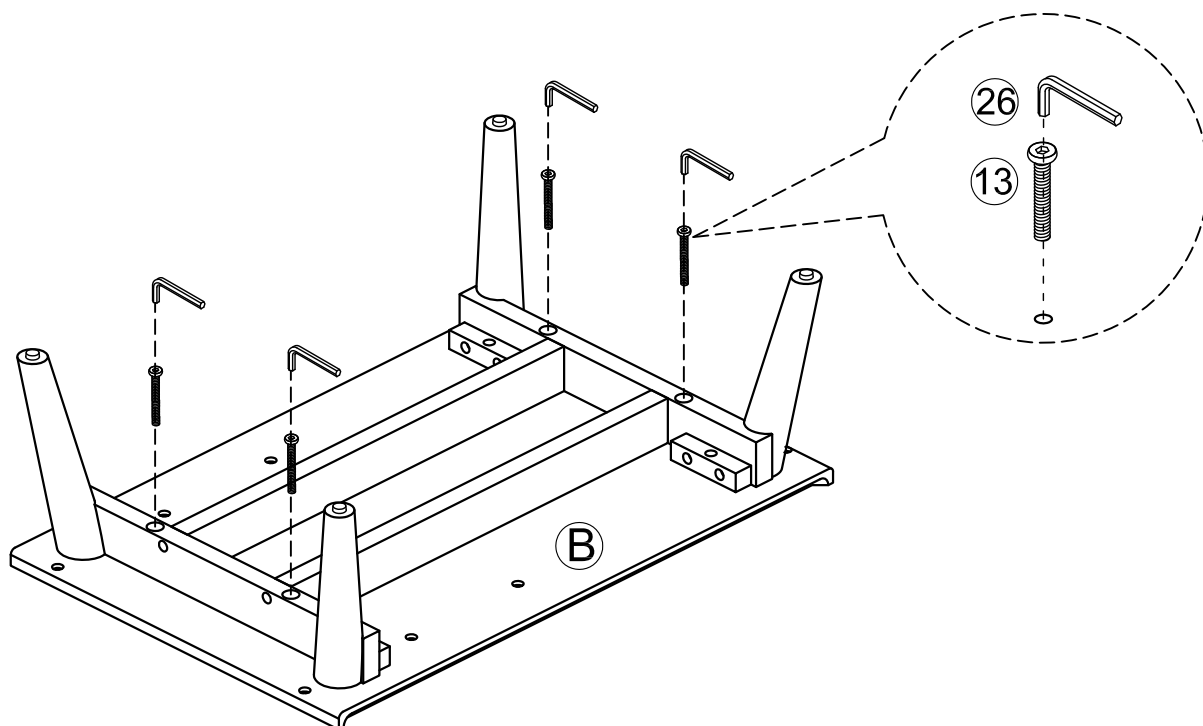
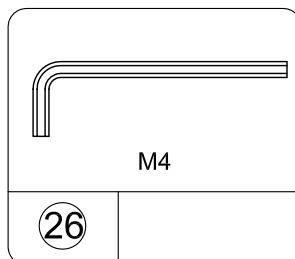
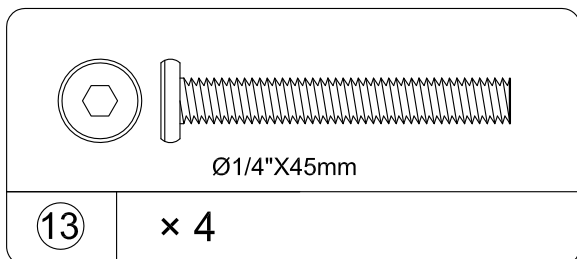

Note: Tighten all bolts to secure the unit in this assembly step.

STEP 7

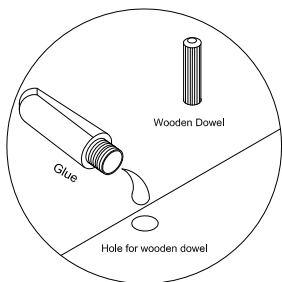
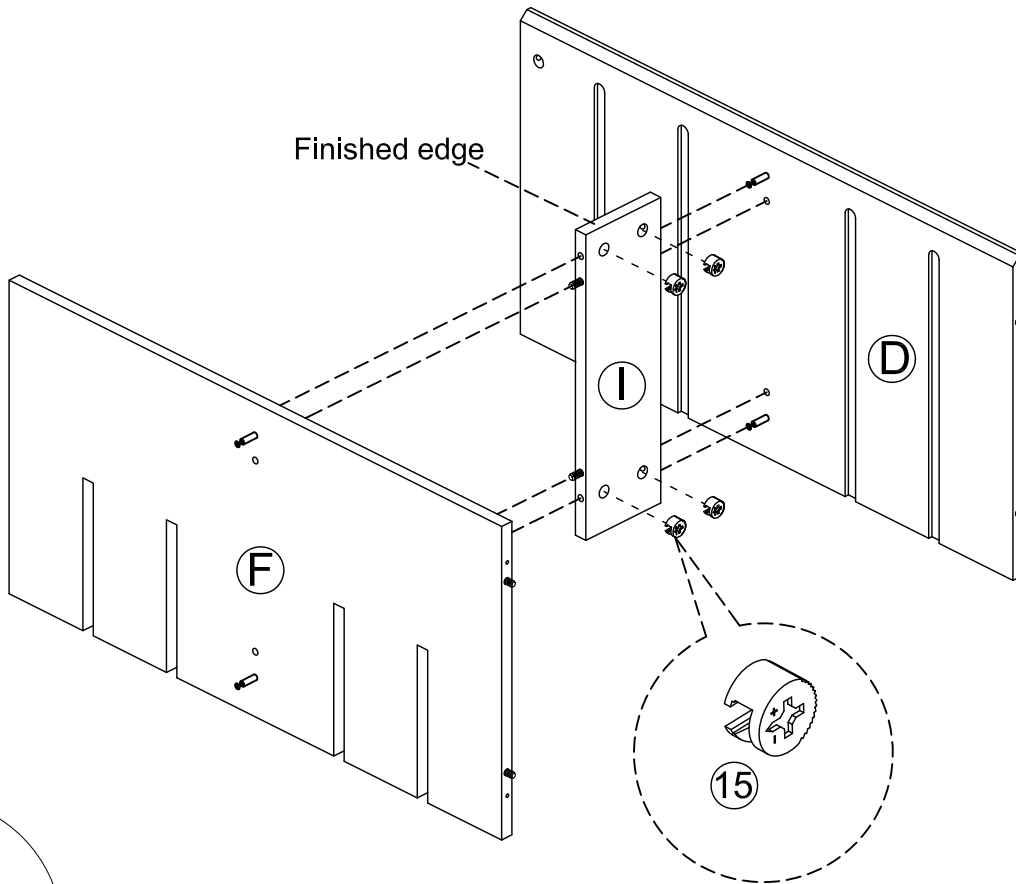
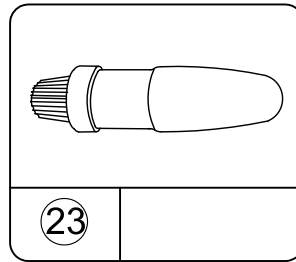
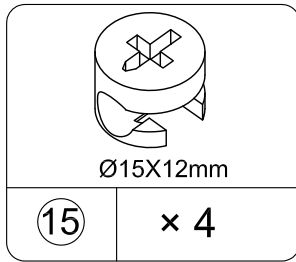
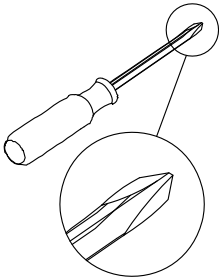

Use one drop of glue in dowel hole.

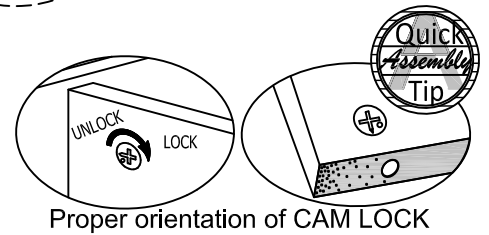

STEP 8

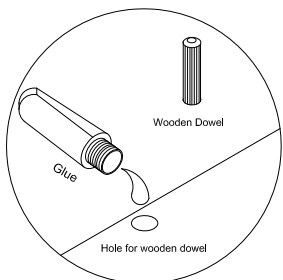
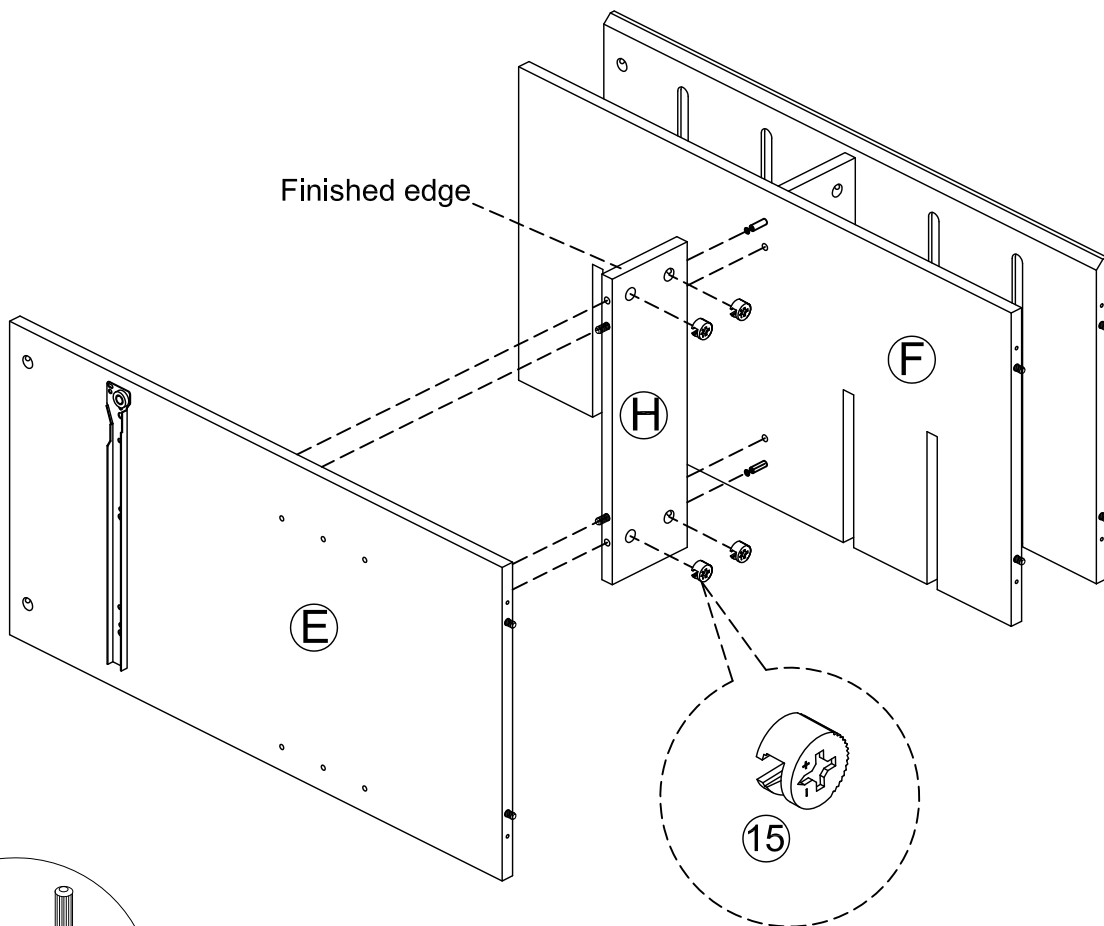
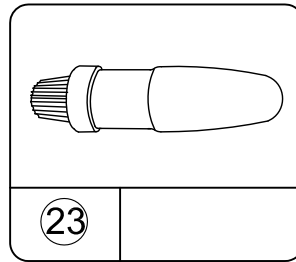
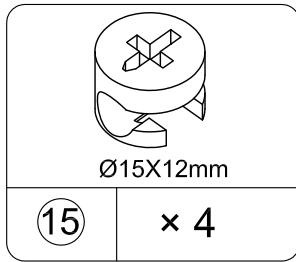
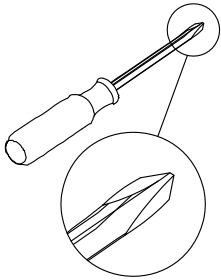

Use one drop of glue in dowel hole.

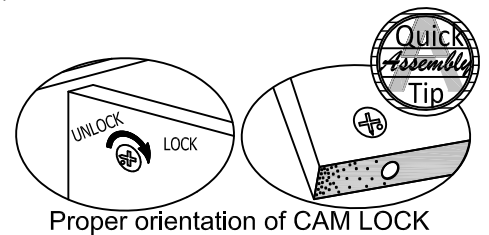

STEP 9

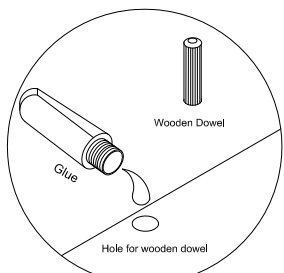
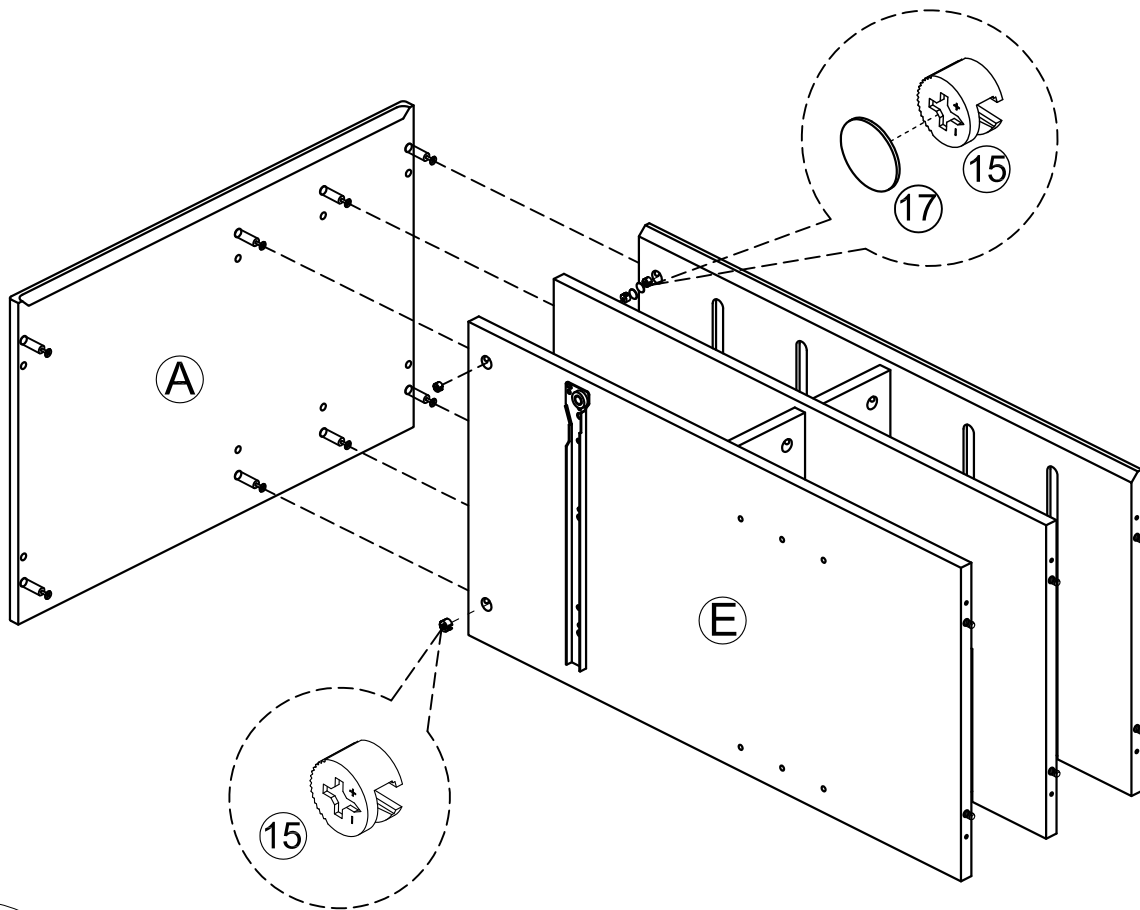
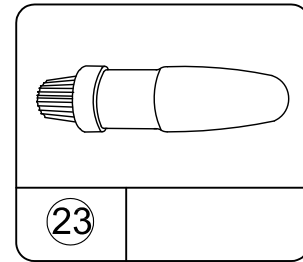
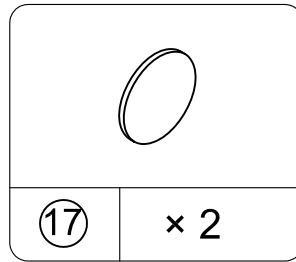
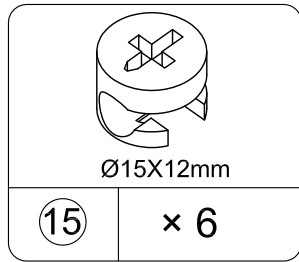
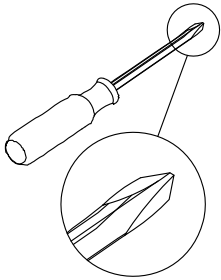

Use one drop of glue in dowel hole.

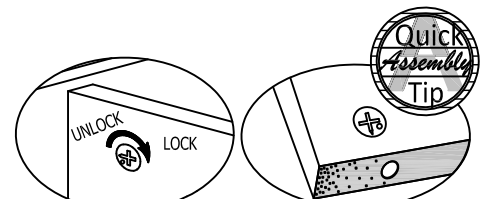

Proper orientation of CAM LOCK

STEP 10

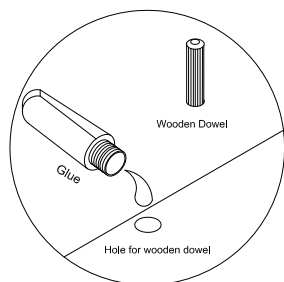
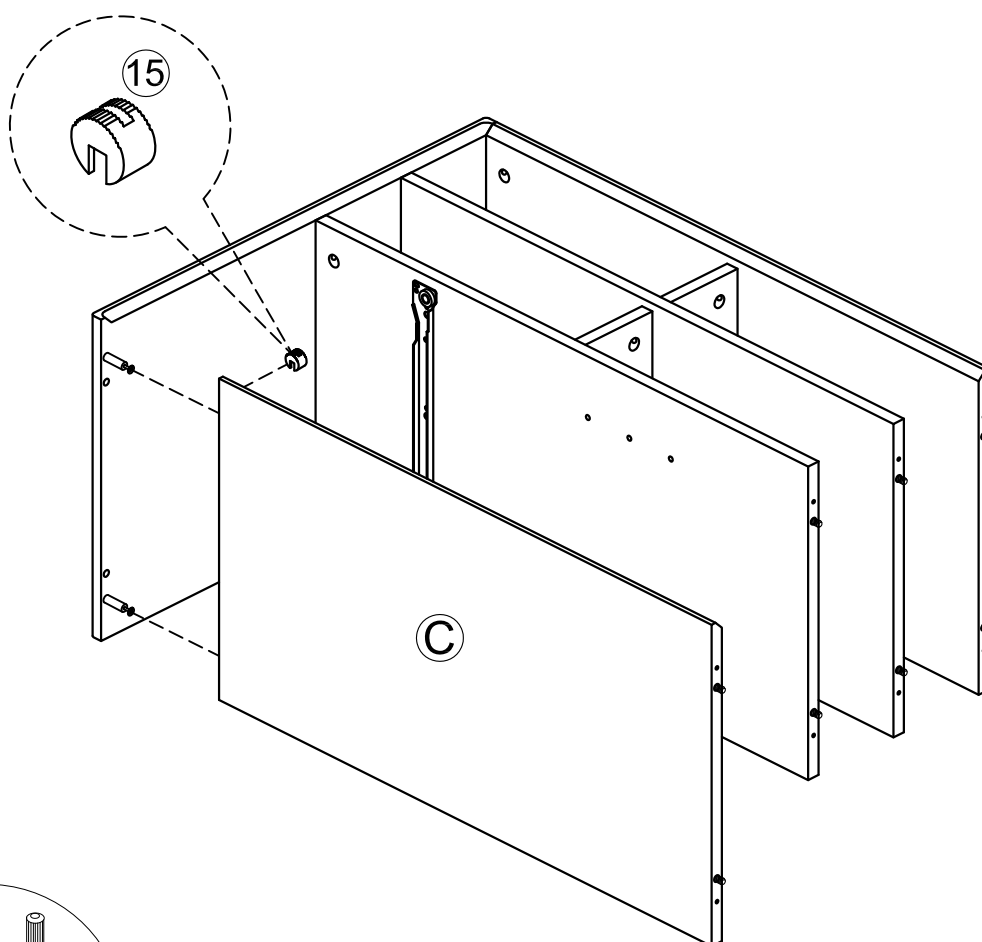
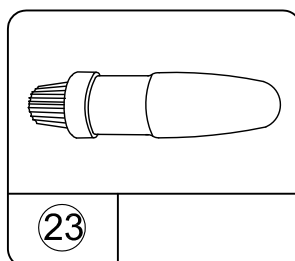
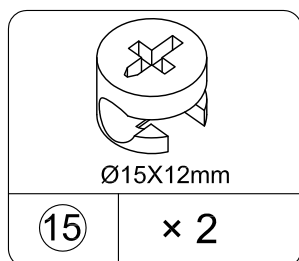
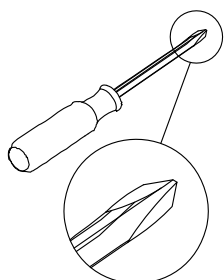

Use one drop of glue in dowel hole.

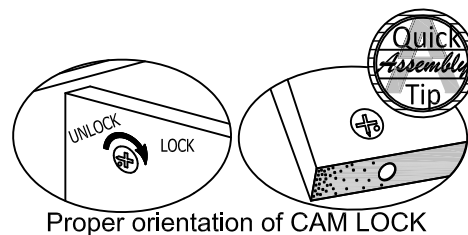

STEP 11

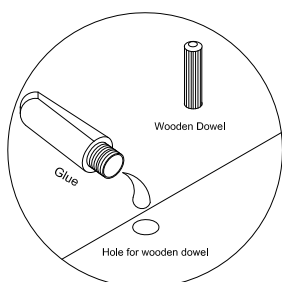
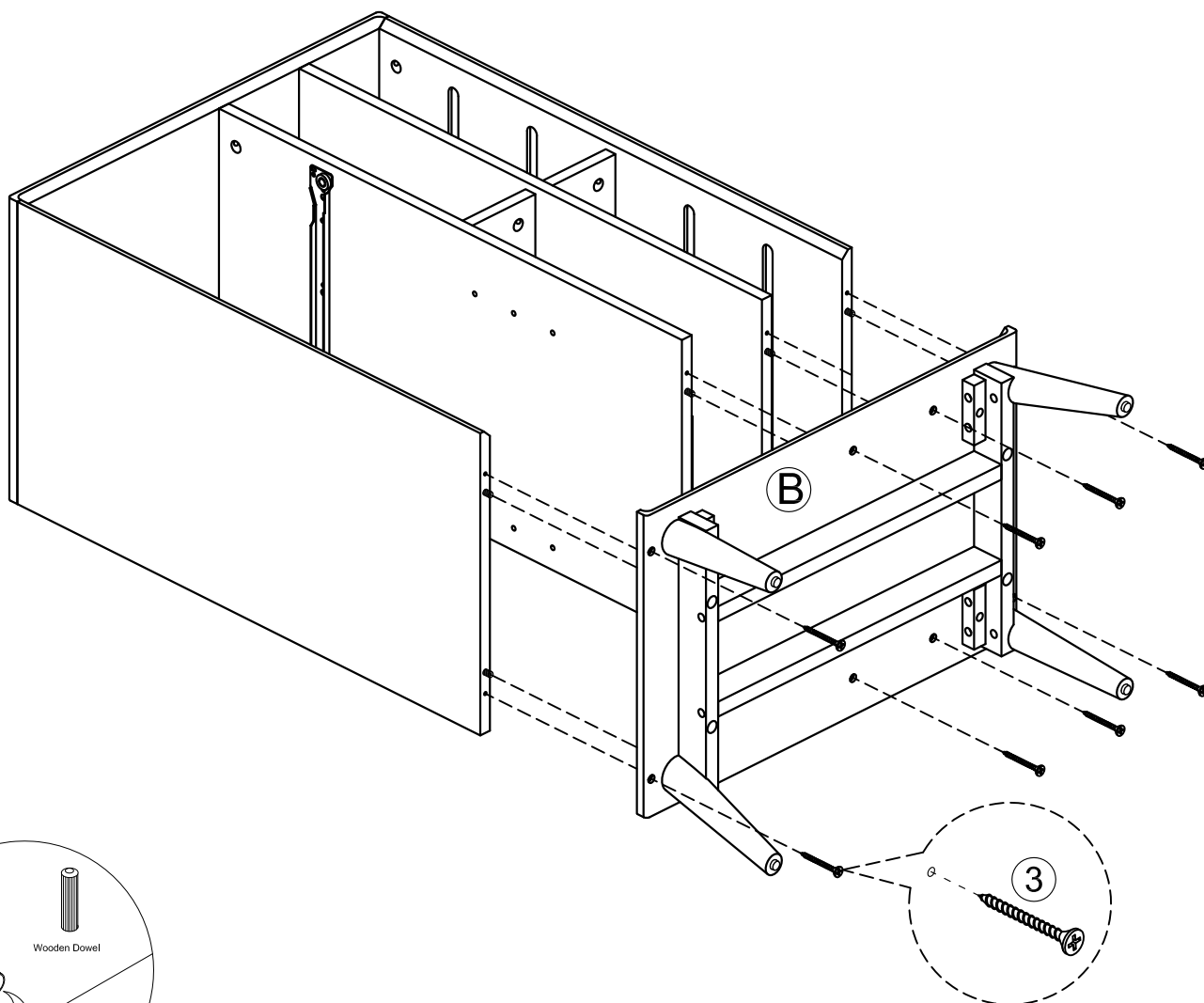
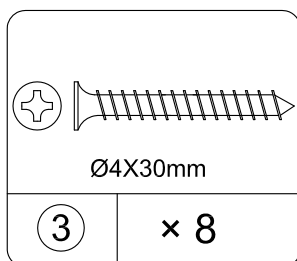
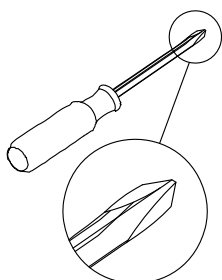

Use one drop of glue in dowel hole.

STEP 12

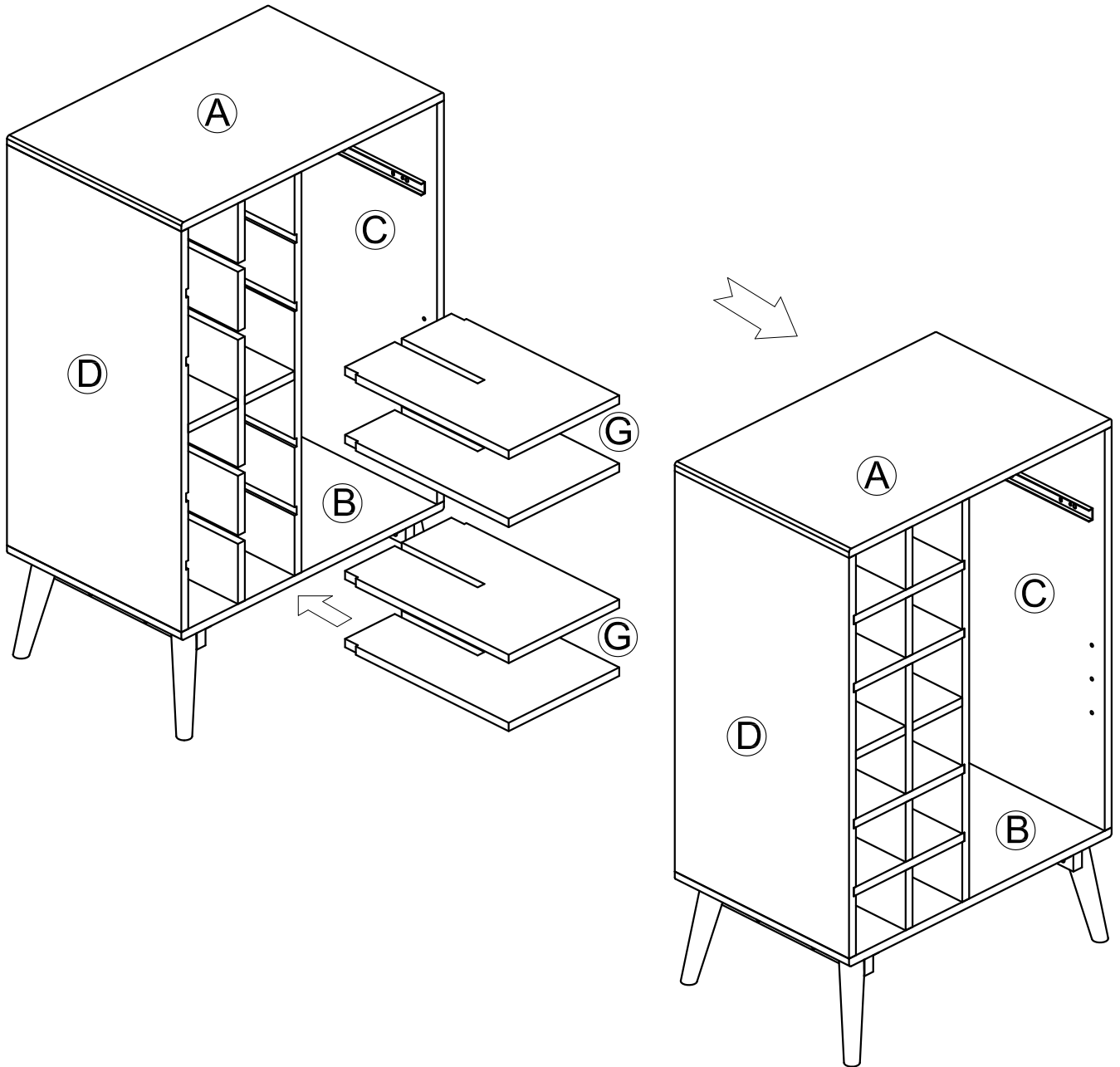

STEP 13

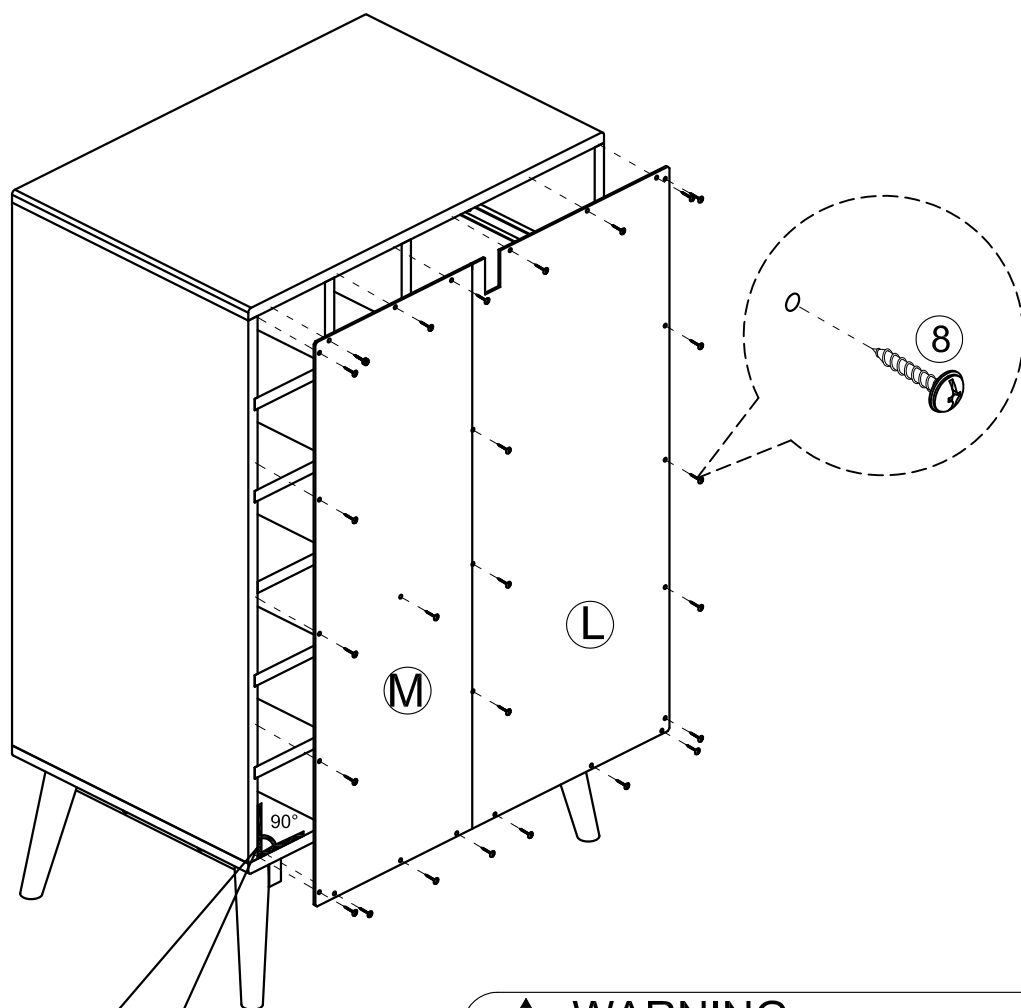
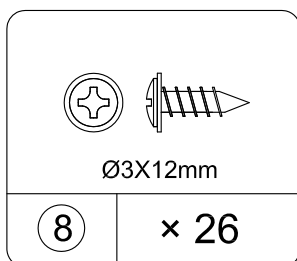
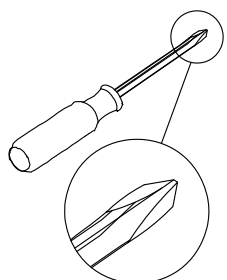

Before attaching the back panel be sure that the unit is at 90°.

⚠ WARNING
 Please make sure that the backs are attached securely. All screws must be driven into the parts straight and tightened firmly. Failure to do so could cause instability, product collapse, and/or serious injury.

STEP 14

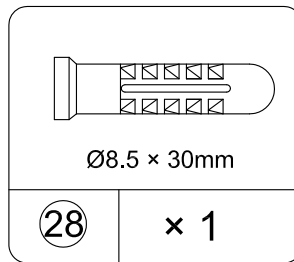
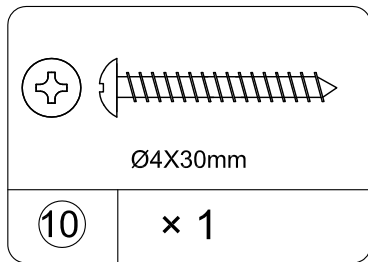
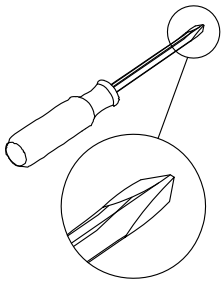

Please note that this unit must be placed against a wall.

Option 1: Fasten the wall bracket (27) to a stud in the wall with the screw (10).

Option 2: Drill a 5 mm (3/16") diameter hole in the wallboard. Tap the wall anchor (28) into the hole until it is flush. Fasten the wall bracket (27) to the wall anchor (28) with the screw (10).

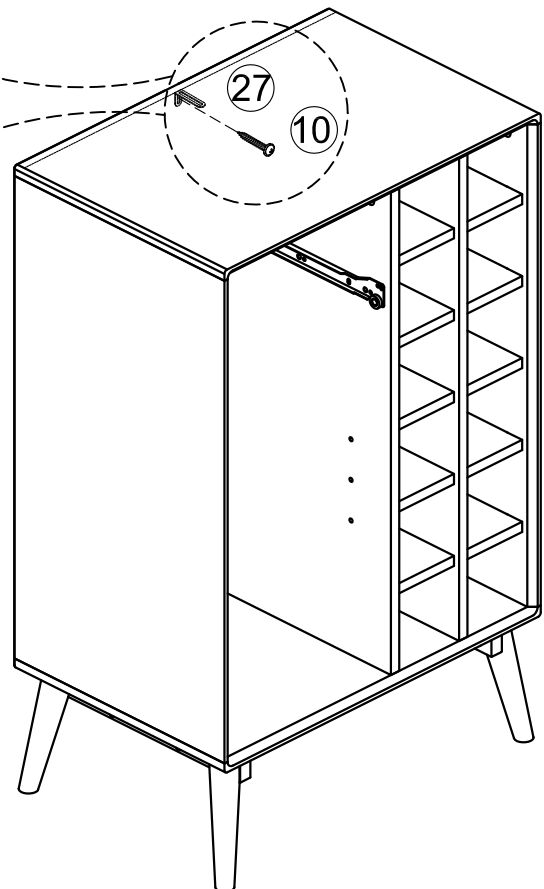
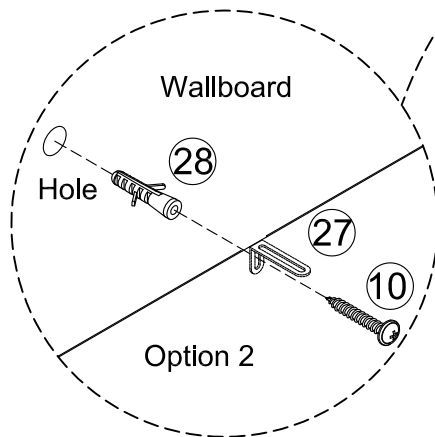
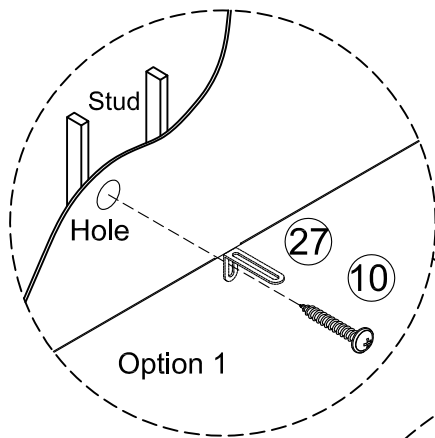

⚠ WARNING

This unit must be anchored to a stud or wall as show. Failure to do so could cause severe injury.

STEP 15

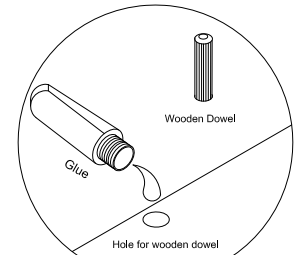
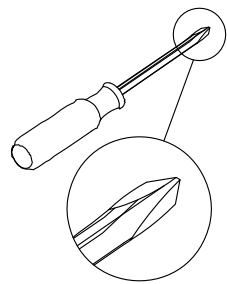
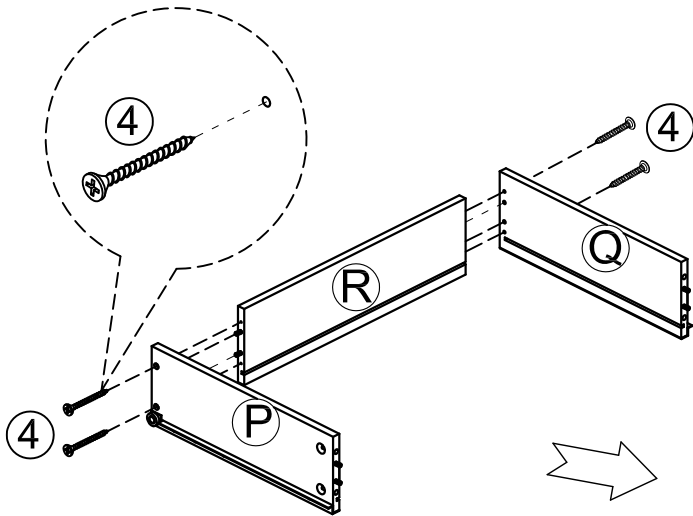
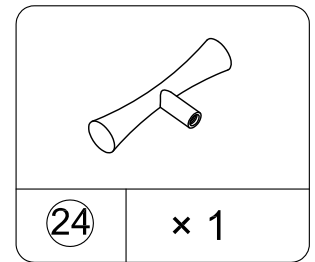
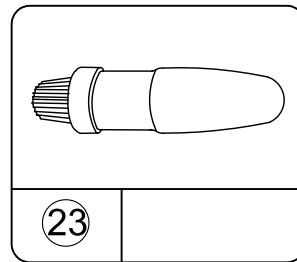
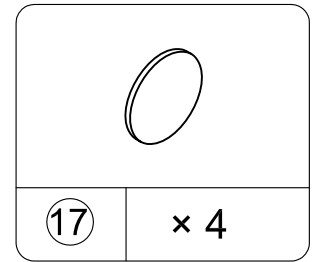
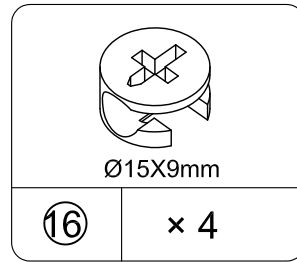
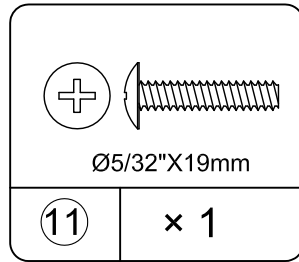
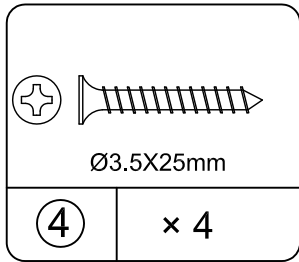

Use one drop of glue in dowel hole.

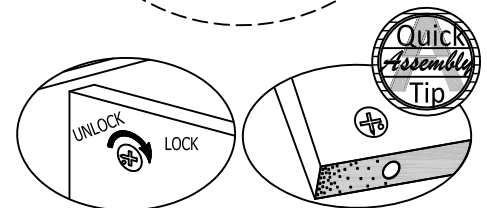
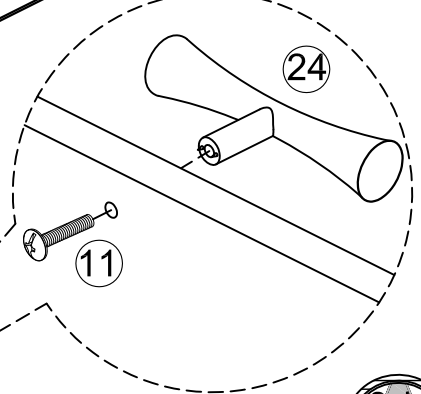
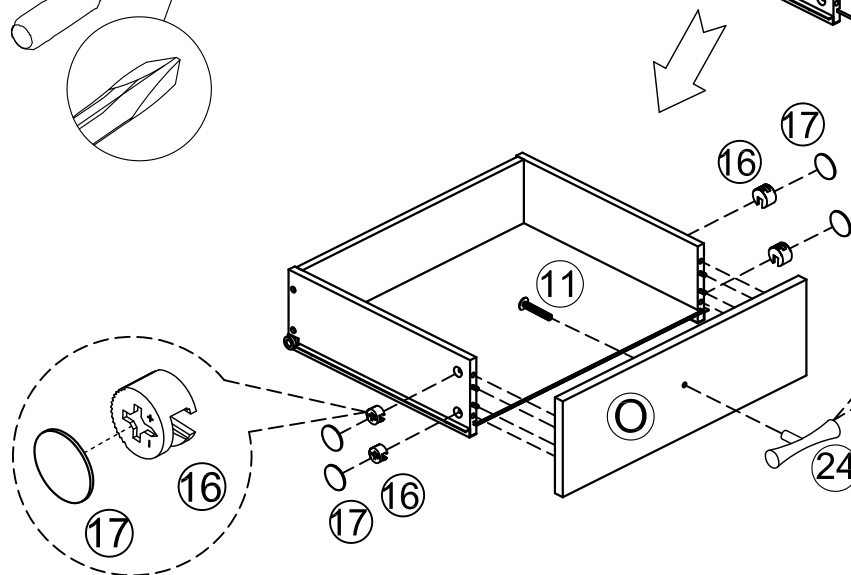
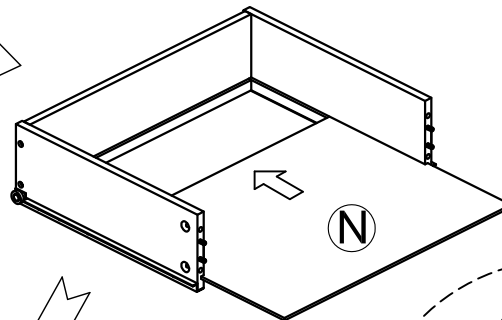

Proper orientation of CAM LOCK

Quick
Assembly
Tip

STEP 16

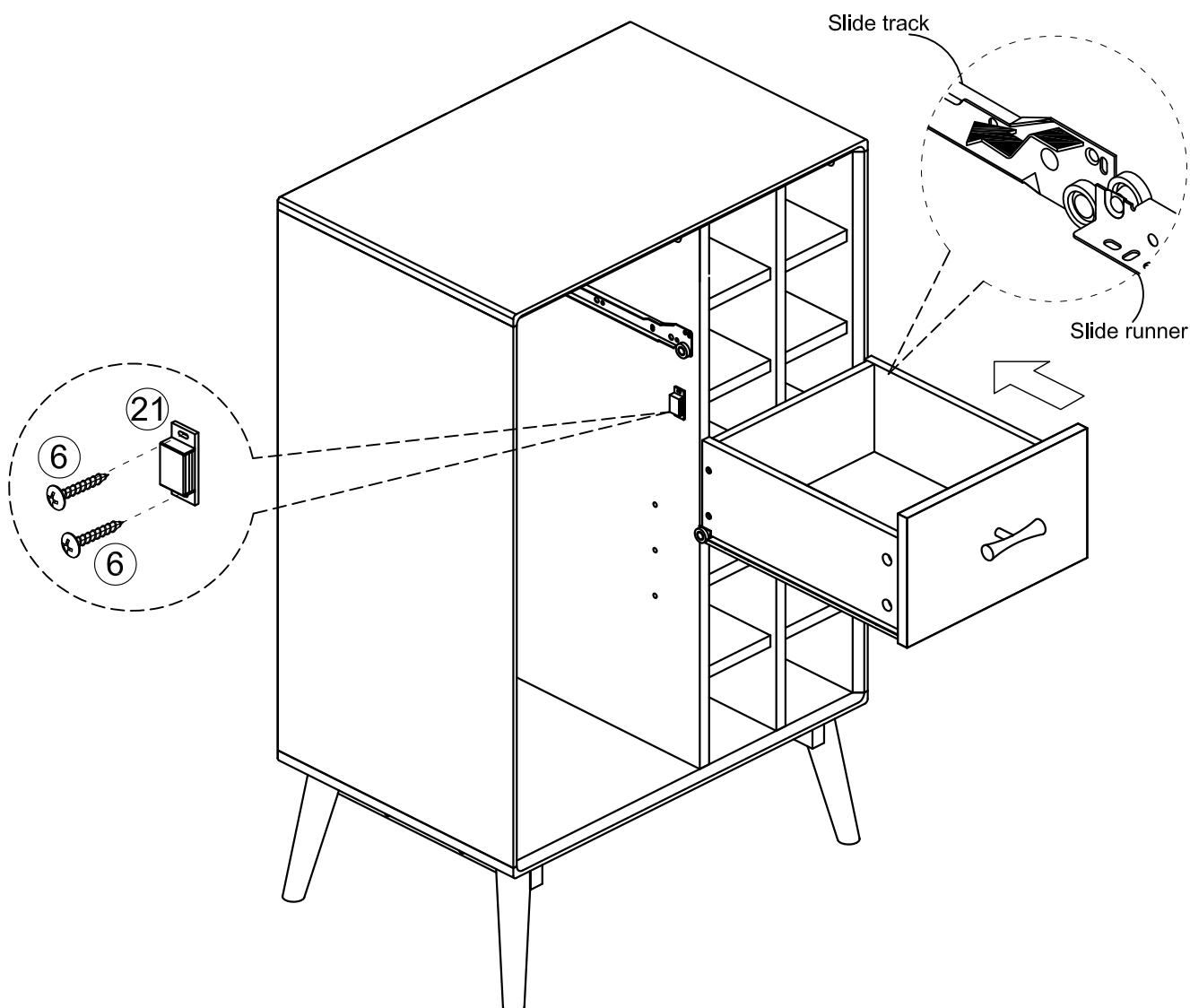
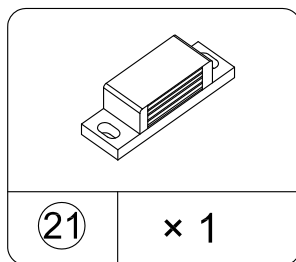
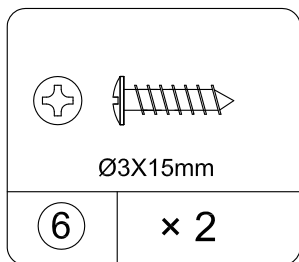
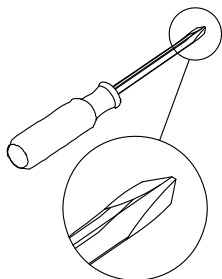



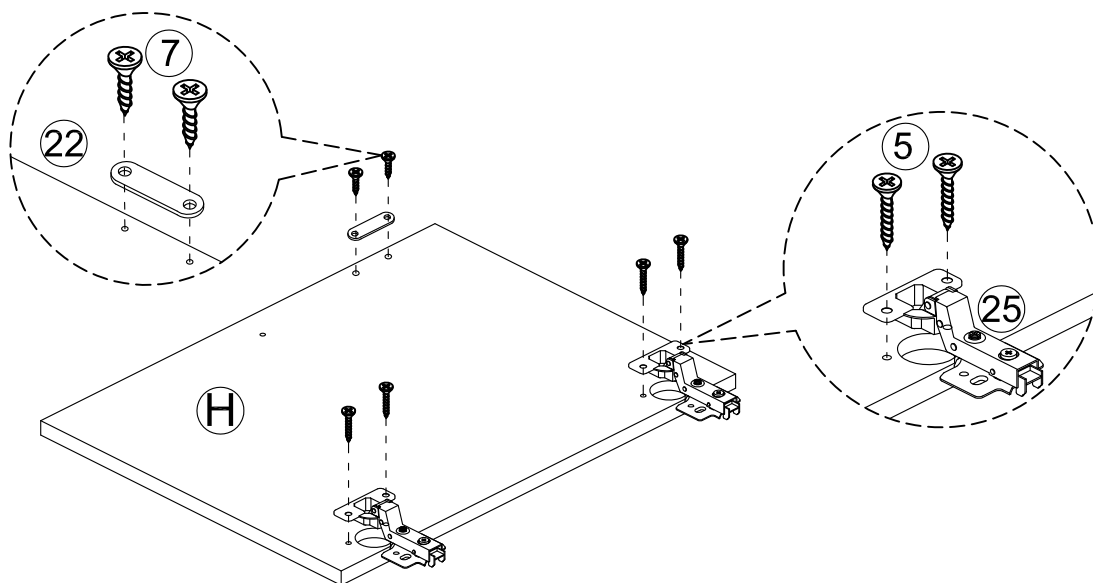
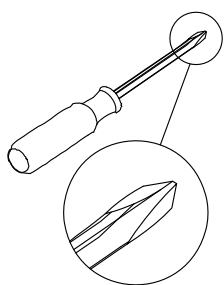
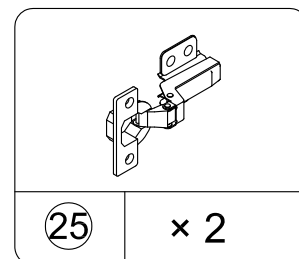
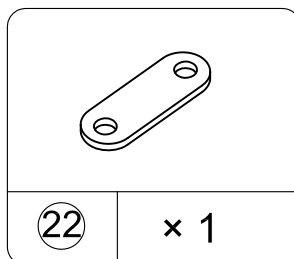
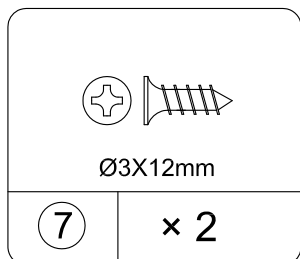
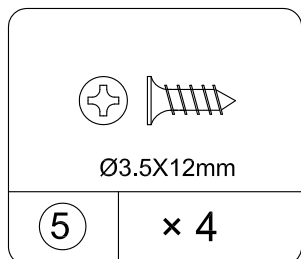

STEP 17

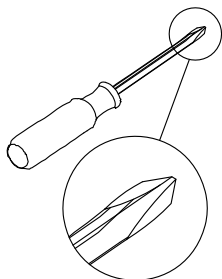

STEP 18



  Ø3.5X12mm	
5	× 8

  Ø5/32"X19mm	
11	× 1

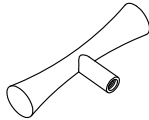
	
24	× 1

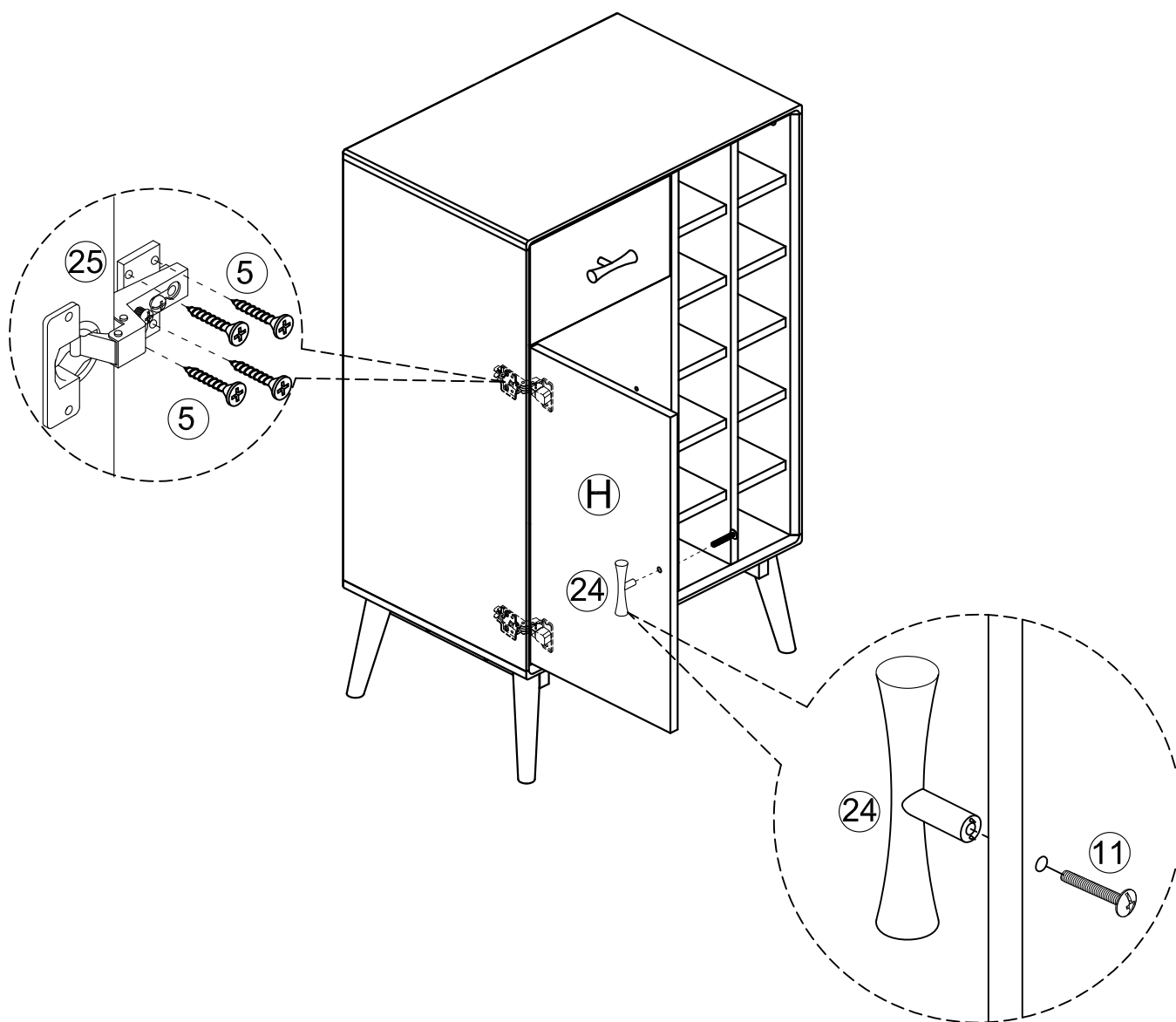

STEP 19

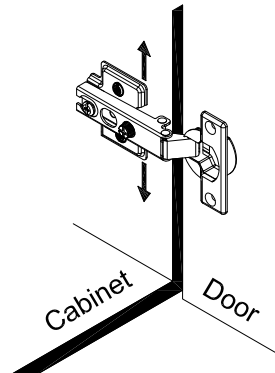
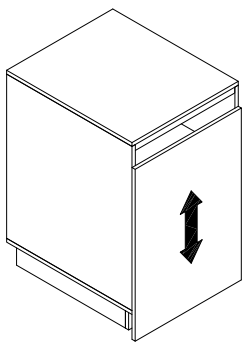
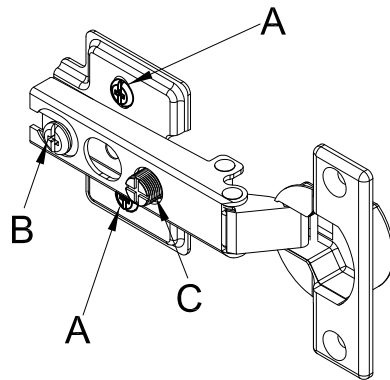

To adjust the vertical height.

Loosen the four screws "A" on both hinges. Two of them are usually in slotted holes which allows you to adjust up or down by a few mm. Then tighten back up.

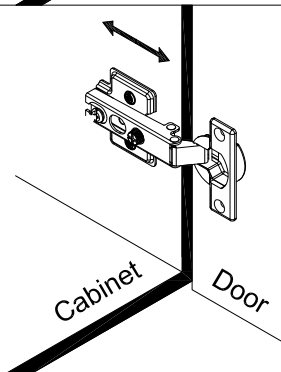
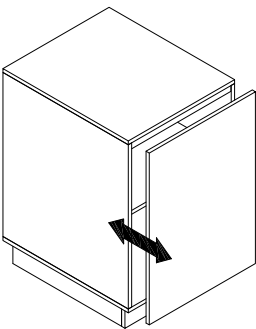

To adjust depth.

Loosen screw "B" and adjust door, if the door can not be adjusted, please loosen screw "C", then try again. Tighten screw "B" and "C".

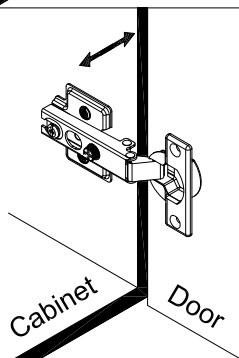
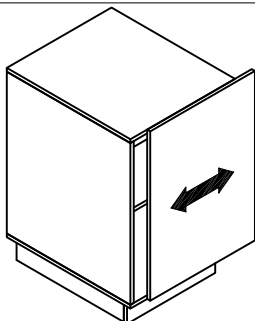

To adjust side ways.

Turning the screw "C" on BOTH hinges on each door.

STEP 20

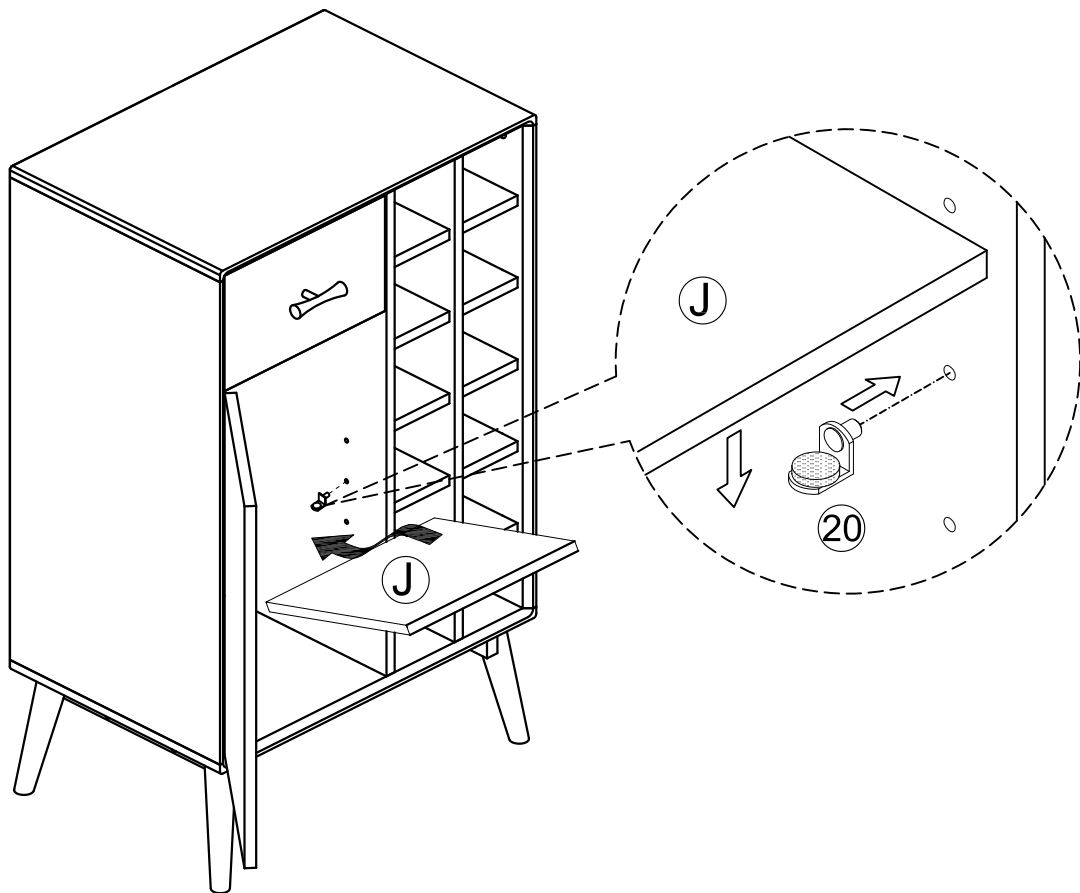
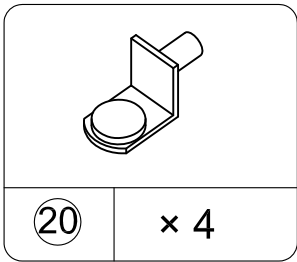

Maximum Loads

This unit has been designed to support the maximum loads shown. Exceeding these load limits could cause sagging, instability, product collapse, and/or serious injury.

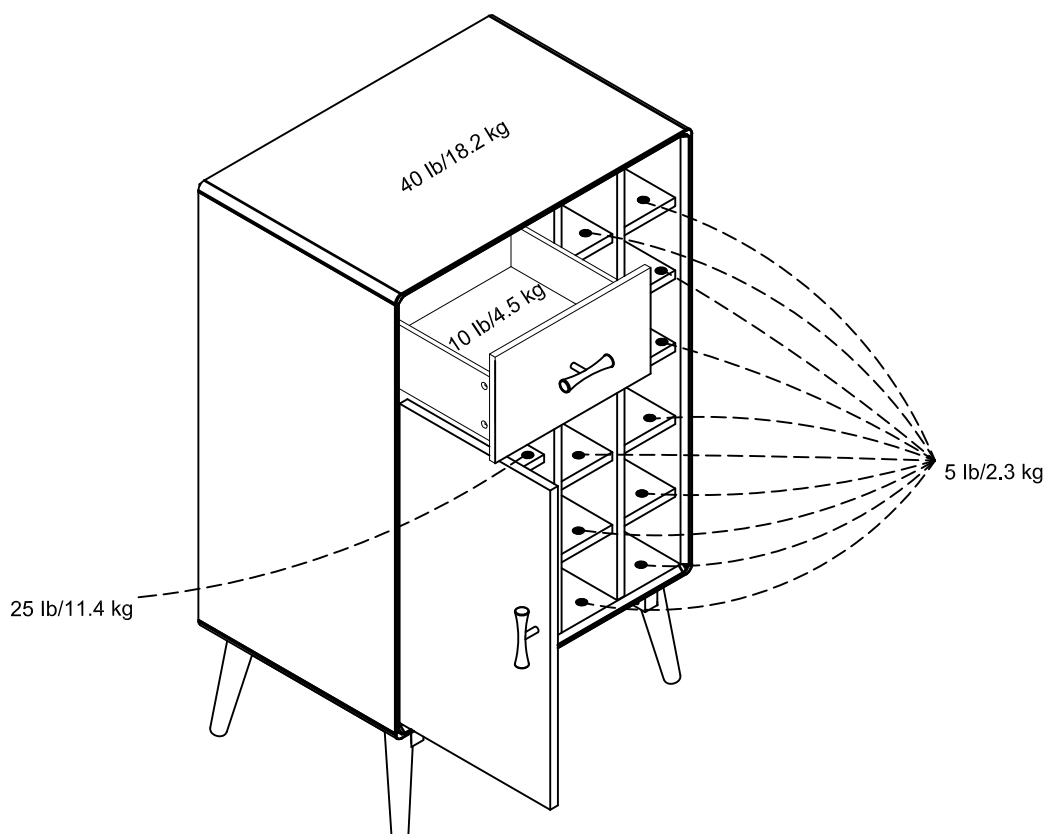

Warning: Risk of injury to persons - do not place a television on this furniture. This furniture is not approved for use with a television.

Certificate of Conformity

1. This certificate applies to the Dorel Home Furnishings, Inc. product identified by this instruction manual.
2. This certificate applies to compliance of this product with the CPSC Ban on Lead-Containing Paint (16 CFR 1303).
3. This product is distributed by: Dorel Home Furnishings, Inc.
410 East First Street South
Wright City, MO 63390
636-745-3351
4. Site of Manufacture: Svay Rieng, Cambodia
5. See front page of instruction manual for date of manufacture.

Register your product to receive the following:



- * New trend details - sneak peek on what's new
- * Surveys - have a voice within our community
- * Exclusive deals and discount codes
- * Quick and easy replacement part service

To register your product, visit ameriwoodhome.com

Star Rating



Visit your local retailer's website, rate your purchased product and leave us some feedback!

We would like to extend a big "Thank You" to all of our customers for taking the time to assemble this Ameriwood Home product, and to give us your valuable feedback.

*Thank
You!*

Español

Cubierta Delantera

Este libro de instrucciones contiene información **IMPORTANTE** de seguridad. Por favor lea y manténgalo para referencia en el futuro.

No Regrese este producto! Comuníquese con nuestro amistoso equipo de servicio al cliente para obtener ayuda.

Llámenos al: 1-800-489-3351 (Gratis) Lunes - Viernes 9am - 5pm CST

Visitar: www.ameriwoodhome.com

PRECAUCION

Este mueble puede volcarse y causar graves heridas y/o muerte.

Anclar el mueble a un poste de madera en la pared (si esto se requiere).

No Permita que los niños monten el mueble.

Mantenga los artículos más pesados en los cajones de abajo.

Consejos Útiles (página 2)

- Abra su artículo en el área donde usted planea utilizarlo para evitar levantar y moverlo menos
- Identificar, ordenar y contar las piezas antes de intentar ensamblar
- Las clavijas de compresión se golpean con un martillo
- Las diapositivas están marcadas con una R (derecha) y L (izquierda) para la colocación correcta
- Asegúrese de que siempre este el punto localizado en la parte superior de bloqueador de leva este volteado hacia borde exterior
- Utilizar todos los clavos para el panel de atrás y distribuirlos por igual
- El panel de atrás debe utilizarse para asegurarse de que la unidad quede fija y firme
- No use químicas fuertes ni limpiadores abrasivos en este artículo
- Nunca empuje, tire ni arrastre los muebles

Antes de Que Empieces (página 3)

- Lea cuidadosamente cada paso y siga el orden correcto

- Separar y contar todas sus piezas y hardware

- Dése suficiente espacio para el proceso de ensamble

- Tenga las siguientes herramientas: destornillador de cabeza plana, #2 cabeza Phillips

Destornillador y martillo

- Precaución: Si usa un taladro electrónico o un destornillador eléctrico para atornillar, por favor asegúrese que deje de atornillar cuando el tornillo este apretado. Fallar hacer esto puede causar barrer el tornillo.

Sistema de fijar el bloqueo de leva (página 3)

Este sistema de fijar el bloqueo de leva será usado en todo el proceso ensamble.

Español

Identificación de los Paneles (Página 4-5)

Este no es el tamaño real

- (A) Panel superior
- (B) Panel base
- (C) Panel izquierdo
- (D) Panel lateral derecho
- (E) Partición
- (F) Separador
- (G) Estante de vino
- (H) Repisa fija
- (I) Repisa fija
- (J) Repisa ajustable
- (K) Puerta
- (L) Panel trasero izquierdo
- (M) Panel trasero derecho
- (N) Fondo del cajón
- (O) Frente del cajón
- (P) Lado izquierdo del cajón
- (Q) Lado derecho del cajón
- (R) Panel trasero del cajón
- (S) Soporte inferior
- (T) Marco de pata

Lista de Piezas (Página 7)

Tamaño real

- (1) Clavija de madera
- (2) Clavija de madera
- (3) Tornillo
- (4) Tornillo
- (5) Tornillo
- (6) Tornillo
- (7) Tornillo
- (8) Tornillo
- (9) Tornillo
- (10) Tornillo
- (11) Tornillo
- (12) Tornillo
- (13) Tornillo
- (14) Tornillo de rosca

Lista de Piezas (Página 8)

Este no es el tamaño real

- (15) Tornillo de cerradura
- (16) Tornillo de cerradura
- (17) Tapa de la leva
- (18) Arandela
- (19) Arandela de resorte
- (20) Soporte de repisa
- (21) Agarrador magnético
- (22) Placez de metal
- (23) Pegamento
- (24) Manija
- (25) Bisagra
- (26) Llave en L
- (27) Soporte para la pared
- (28) Ancla de pared

Página 9,10,11,12

Agujero para clavija de madera. Use una gota de pegamento en el agujero de clavija.

Página 13

Nota: NO APRIETE el perno para asegurar un ensamblaje exitoso en este paso.

Página 14

Nota: Apriete todos los pernos para estabilizar la unidad en este paso.

Página 15,16,17,18,19

Agujero para clavija de madera. Use una gota de pegamento en el agujero de clavija.

Página 21

ADVERTENCIA

Asegúrese de que los paneles traseros están bien sujetos. Todos los tornillos deben ser atornillados en las partes rectas y estar bien apretados. No hacerlo puede resultar en inestabilidad, derrumbe de mueble y/o lesiones graves.

Antes de atar el panel trasero asegúrese de que se encaja bien con la unidad.

Español

Página 22

Tenga en cuenta que esta unidad debe colocarse contra una pared.

Opción 1: Fije la abrazadera de pared (27) a un montante de la pared con el tornillo (10).

Opción 2: Taradre un agujero de 5mm (3/16") de diámetro en la pared. Introduzca el soporte de pared (28) hasta que el agujero quede plano. Fije la abrazadera (27) al soporte de pared (28) con el tornillo (10).

ADVERTENCIA: Esta unidad debe ser anclada contra un montante o pared como se muestra. El no hacerlo podría causar lesiones graves.

Página 23

Agujero para clavija de madera. Use una gota de pegamento en el agujero de clavija.

Página 27

Para ajustar la altura vertical.

Afloje los cuatro tornillos "A" en ambas bisagras. Por lo general dos de ellos tienen agujeros acanalados que permite ajustar hacia arriba o hacia abajo la altura por unos milímetros. Después de esto, apriete los tornillos.

Para ajustar la profundidad.

Afloje el tornillo "B" y ajuste la puerta. Si la puerta no está alineada, afloje el tornillo "C" y vuelva a probar. Apriete el tornillo "B" y "C"

Para ajustar lateralmente.

Dele un giro a los tornillos "C" en las dos bisagras de cada puerta.

Español

Página 29

CARGA MAXIMA

Esta unidad ha sido diseñada para soportar la carga máxima anotada. El exceder estos límites puede causar inestabilidad, colapsarse y/o causar serias lesiones.

ADVERTENCIA: Riesgo de lesiones a las personas - no coloque un televisor sobre muebles. Este mueble no está aprobado para su uso con un televisor.

Página 30

Registre su producto para recibir lo siguiente:

- * Detalles de nuevas tendencias - Vistazo a lo nuevo
- * Encuestas - alec su voz entre su comunidad
- * Códigos de ofertas y descuentos exclusivos
- * Fácil y rápido servicio de partes de remplace

Para registrar su producto, visite ameriwoodhome.com

Clasificación de 5 estrellas

Visite el sitio web de su tienda local, califique su comprado y denos sus comentarios!

Nos gustaría enviar un gran "Agradecimiento" a todos nuestros clientes por tomarse el tiempo de ensamblar este producto de Ameriwood Home, y por darnos sus valiosos comentarios.

Gracias

Français

Couverture Avant

CE LIVRET D'INSTRUCTION CONTIENT DES INFORMATIONS IMPORTANTES SUR LA SÉCURITÉ. VEUILLEZ LIRE ET GARDER POUR UNE RÉFÉRENCE FUTURE

Ne retournez pas ce produit! Contactez notre équipe de service à la clientèle amicale d'abord pour obtenir de l'aide.

Appelez-nous: 1-800-489-3351 (sans frais) du Lundi au Vendredi de 9h à 17h Heure Centrale

Visitez: www.ameriwoodhome.com

ATTENTION

Le meuble peut basculer et causer des blessures graves ou la mort.

Ancrer le meuble à une planche murale dans le mur (si indiqué).

Ne laissez pas les enfants grimper sur le meuble.

Placez les articles lourds sur les étagères ou dans les tiroirs inférieurs.

Astuces Utiles (page 2)

- Ouvrez votre article dans la zone que vous prévoyez de le garder pour moins de levage lourd
- Identifier, trier et compter les pièces avant d'essayer d'assembler
- Les goujons de compression sont taraudés avec un Marteau
- Les glissières sont marquées d'un R (droit) et d'un L (gauche) pour un bon placement
- Assurez-vous toujours de faire face la pointe situé sur le haut de la Serrure de Came vers le bord extérieur
- Utiliser tous les clous fournis pour le panneau arrière et les répartir également
- Le panneau arrière doit être utilisé pour vous assurer que votre appareil est robuste
- N'utilisez pas de produits chimiques agressifs ou de nettoyeurs abrasifs sur cet appareil
- Ne jamais pousser, tirer, ou faire glisser votre meuble

Avant de Commencer (page 3)

- Lisez attentivement chaque étape et suivez le bon ordre
- Séparez et comptez toutes vos pièces et matériaux
- Donnez-vous suffisamment de place pour l'assemblage
- Avoir les outils suivants: tournevis à tête plate, #2 tournevis Phillips, et Marteau
- Attention: Si vous utilisez une perceuse électrique ou un tournevis électrique pour visser, veillez à ralentir et arrêter lorsque la vis est bien serrée. Le non-respect de cette consigne peut endommager la vis.

Système de Fixation de Came (page 3)

Ce Système de Fixation de Came sera utilisé tout au long de l'assemblage

Français

Identification des matériaux (Page 4~5)

Pas de taille réelle

- (A) Panneau supérieur
- (B) Panneau inférieur
- (C) Panneau gauche
- (D) Panneau droit
- (E) Cloison
- (F) Séparateur
- (G) Étagère à vin
- (H) Tablette fixe
- (I) Tablette fixe
- (J) Tablette réglable
- (K) Porte
- (L) Panneau arrière gauche
- (M) Panneau arrière droit
- (N) Fond de tiroir
- (O) Devant de tiroir
- (P) Côté gauche du tiroir
- (Q) Côté droit de tiroir
- (R) Dos de tiroir
- (S) Support inférieur
- (T) Cadre de patte

Liste des pièces (Page 7)

Taille réelle

- (1) Goujon en bois
- (2) Goujon en bois
- (3) Vis
- (4) Vis
- (5) Vis
- (6) Vis
- (7) Vis
- (8) Vis
- (9) Vis
- (10) Vis
- (11) Boulon
- (12) Boulon
- (13) Boulon
- (14) Boulon de came

Liste des pièces (Page 8)

Pas de taille réelle

- (15) Serrure de came
- (16) Serrure de came
- (17) Abri de la came
- (18) Rondelle
- (19) Rondelle à ressort
- (20) Support de tablette
- (21) Loquet magnétique
- (22) Plaque métallique
- (23) Colle
- (24) Poignée
- (25) Charnière
- (26) Clé hexagonale
- (27) Support mural
- (28) Ancrage mural

Page 9,10,11,12

Trou pour cheville en bois. Utilisez une goutte de colle dans le trou de la cheville.

Page 13

Note: NE PAS serrer le boulon complètement à cette étape pour faciliter l'assemblage.

Page 14

Note: Serrez tous les boulons à cette étape pour bien fixer l'unité.

Page 15,16,17,18,19

Trou pour cheville en bois. Utilisez une goutte de colle dans le trou de la cheville.

Page 21

AVERTISSEMENT

S'il-vous-plaît assurez-vous que les PANNEAUX ARRIÈRE sont attachés solidement. Tous les clous doivent être enfoncés perpendiculairement et solidement dans les parties. Sinon le meuble peut devenir instable, s'effondrer subitement et/ou causer des blessures graves.

Avant de fixer le panneau arrière, assurez-vous que l'unité est d'équerre à 90°.

Page 22

Veillez noter que ce meuble doit être placé contre un mur.

Option 1: Fixez le support mural (27) à un montant dans le mur avec la vis (10).

Option 2: Percez un trou de 5mm (3/16") de diamètre dans le mur. Enfoncez l'ancrage mural (28) dans le trou jusqu'à ce qu'il soit affleurant. Fixez le support mural (27) à l'ancrage mural (28) avec la vis (10).

Avertissement: Ce meuble doit être ancré à un montant ou à un mur comme indiqué. Le non-respect de cette consigne peut entraîner des blessures graves.

Page 23

Trou pour cheville en bois. Utilisez une goutte de colle dans le trou de la cheville.

Page 27

Pour régler la hauteur verticale.

Desserrez les quatre vis "A" sur les deux charnières. Deux d'entre elles sont généralement dans des trous fendus qui vous permettent de régler vers le haut ou vers le bas de quelques mm. Puis, resserrez.

Pour régler la profondeur

Desserrez la vis "B" et réglez la porte, si la porte ne peut pas être ajustée, veuillez desserrer la vis "C", puis essayez de nouveau. Serrez la vis "B" et la vis "C".

Pour régler latéralement

Tournez la vis "C" sur les DEUX charnières de chaque porte.

Français

Page 29

CHARGES MAXIMALES

Ce meuble a été conçu pour supporter les charges maximales indiquées. En excédant ces limites de charge, le meuble pourrait devenir instable, s'effondrer, et/ou causer des blessures graves.

AVERTISSEMENT : Risque de blessure corporelle - ne pas placer une télévision sur ce meuble. Ce meuble n'est pas approuvé pour une utilisation avec une télévision.

Page 30

Enregistrez votre produit pour recevoir les éléments suivantes:

- * Détails sur les nouvelles tendances - un aperçu sur les nouveautés
- * Sondages - avoir une voix au sein de notre communauté
- * Offres exclusives et codes promo
- * Service de pièces de rechange rapide et facile

Pour enregistrer votre produit, visitez ameriwoodhome.com

5 Étoiles

Visitez le site Web de votre détaillant local, évaluez votre produit acheté et laissez-nous quelques commentaires !

Nous tenons à offrir un grand "Merci" à tous nos clients pour avoir pris le temps d'assembler ce produit "Ameriwood Home", et de nous donner vos commentaires précieux.

Merci