



INSTALLATION MANUAL

ARIEL

ARIEL AM128JDCLZ
Bathtub

THE
ARIEL AM128JDCLZ

Table of Contents

Specs & Packing List	2
Rough-In Spec Diagram	3
General Information & Safety Instructions	4-5
Getting Started	6-7
Skirt & Speaker Assembly	8
Shower Head & Faucet Assembly	9
Drain Assembly	10
Chassis & Water Pump Assembly	11
Faucet Assembly	12-13
Power Supply Assembly	14-15
Keypad Control Instructions	16-17
Water Faucet Control Usage	18
Frequently Asked Questions	19
Warranty Information	20-26

INSTALLATION MANUAL

ARIEL AM128JDCLZ

Specs & Packing List

ARIEL

Electrical Specifications

- **Voltage**

110V/20 Amps

Included Parts:

Keypad Controller

Shower Wand Hose

Main Body

Drain Hose



HARDWARE REQUIRED

**ELECTRIC
DRILL**



**PHILLIPS
SCREWDRIVER**



WRENCH



**MEASURING
TAPE**

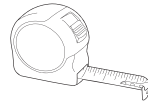

**CAULKING
GUN**

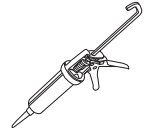

**WATERPROOF KITCHEN/
BATH SILICONE**

**TWO 1/2" STEEL
BRAIDED HOSES
FOR WATER SUPPLY**

ARIEL

ARIEL AM128JDCLZ Rough-In Spec Diagram

Length	70.9"
Width	37.4"
Height	28"

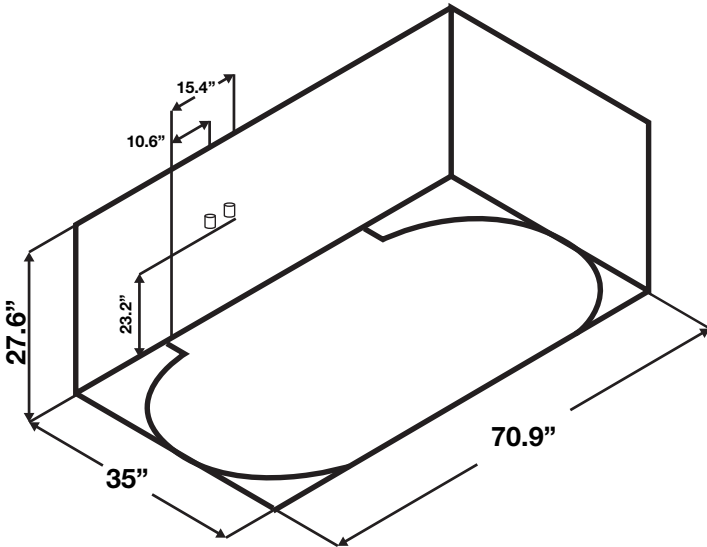
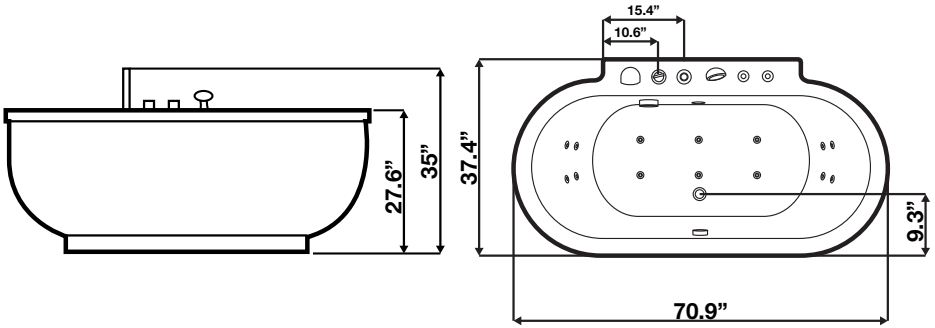

ARIEL AM128JDCLZ

General Information & Safety Instructions

ARIEL

GENERAL INFORMATION

SAVE THIS MANUAL: RETAIN FOR CONSUMER USE

Read these instructions completely before installing the product. If you have any questions please call: (800) 304-3598

You must follow all instructions in this manual:

Failure to do so will result in your assumption of all liability that may occur. Failure to comply with all instructions can result in product damage and personal injury.

RESPONSIBILITY OF THE INSTALLER

The installer must inspect and water test the product prior to installation to ensure the unit is free of defect or damage. In the event of a problem, the unit must not be installed. If the crate or product has been damaged please call immediately:
(800) 304-3598

This product is designed to be installed by a licensed tradesperson, licensed plumbers and electricians should be employed to insure proper installation. Installers assume all liability for the correct installation procedures.

Only accessories authorized by the manufacturer should be used with this product.

SAFETY INSTRUCTIONS

IMPORTANT SAFETY INSTRUCTIONS

1. When using this product, basic precautions should always be followed. Read and follow all instructions pertaining to risk of fire, electric shock, or personal injury.
2. Use this unit only for its intended purposes or as described in this manual. Use only attachments recommended by the

manufacturer.

3. Risk of hyperthermia and possible drowning: Water temperature in excess of 100°F (38°C) may be hazardous to your health. Check and adjust temperature before use.

READ AND FOLLOW ALL INSTRUCTIONS

1. **Danger:** To reduce the risk of injury, do not permit children or disabled persons to use this product unless they are closely supervised at all times.
2. To avoid injury, exercise caution when entering or exiting the tub.
3. Never drop or insert any objects into any openings.
4. Risk of electrical shock; connect only to a separate circuit protected by a ground fault circuit interrupter (GFCI).
5. **Warning:** Risk of electric shock, do not permit electric appliances (such as a hair dryer, lamp, telephone, radio or television) within 5-feet (1.5M) of this hydro massage bathtub.
6. This unit must be connected to a circuit interrupter - (GFCI). Such a circuit is provided by the installer and should be tested on a routine basis. To test the GFCI push the test button, the GFCI should interrupt power. Push the RESET button, power should be restored. If the GFCI fails to operate in this manner, there is a ground current flowing, indicating the possibility of an electrical shock. Do not use this unit. Disconnect the unit and have the problem corrected before using.
7. Traction enhanced-textured tub button must remain clean to minimize slippage.
8. Risk of electrical shock, all pumps and heaters must be connected to a ground fault circuit interrupter(GFCI) protected outlets.
9. Avoid use of alcohol, drugs, or medication while using your tub.
10. Consult your physician before using the whirlpool/air system if you are pregnant and/or have heart conditions.
11. All units must be water tested before installation.

GETTING STARTED

UNPACKING THE UNIT

1. Inspect the carton, if the carton is damaged please note: take a picture if possible, notify the deliverer, write "DAMAGED" on the Proof of Delivery (P.O.D), and call: (800) 304-3598
2. **NEVER LIFT THE TUB BY THE PLUMBING.** Doing so can result in leaks, for which the installer is responsible.
3. Immediately inspect the unit for damage even if there is no carton damage. Once the unit is accepted surface damages will be assumed to be installation related if not reported within 72 hours of delivery. Installers are responsible for damage that occurs once the unit is installed.
4. Inspect the plumbing for any loose fittings.
5. Remove all packaging material except for the protective plastic. This has been placed on the tub at the factory to eliminate abrasions from handling. This should only be removed at final clean up.

TESTING TUB SAFETY BEFORE INSTALLATION

1. All tubs are 100% water tested at the factory and certified to be free of leaks. Transportation and mishandling may cause leaks. It is necessary to test the unit while there is access to all sides of the tub.
2. This unit should be both static and operationally tested with water. It is best to test the unit outside by filling with a garden hose.
 - A. Place the tub on a completely flat surface in an area where it may be drained after testing.
 - B. Seal the drain (can be sealed with tape for test) and fill the tub three inches above the jets or to a normal level if it's a soaking tub.
 - C. Allow the water to stand in tub for 10 minutes and then inspect all plumbing and seals for leaks.

- D. Ensure all jets are open and working (every hydro jet is adjustable for both flow rate and direction of flow, depending on the jet, the water flow is adjusted by either turning the outside ring or the nozzle clockwise and counter clockwise).

Note: If the pumps do not operate:

- A. Check the breaker to insure power is on and the cable connecting the controls to the pump is attached.
- B. If an optional heater is present, check the indicator light on the heater to insure that power is present.

Do not run any pumps unless the tub is filled with water to proper usage level, 4-inches (10cm) above the highest jet fixture. Damage due to dry-running (running pumps without proper water level height) is not covered under any stated warranty.

Failure to perform these tests before installation will make the installer liable for future repair costs.

ARIEL AM128JDCLZ Skirt & Speaker Assembly

ARIEL

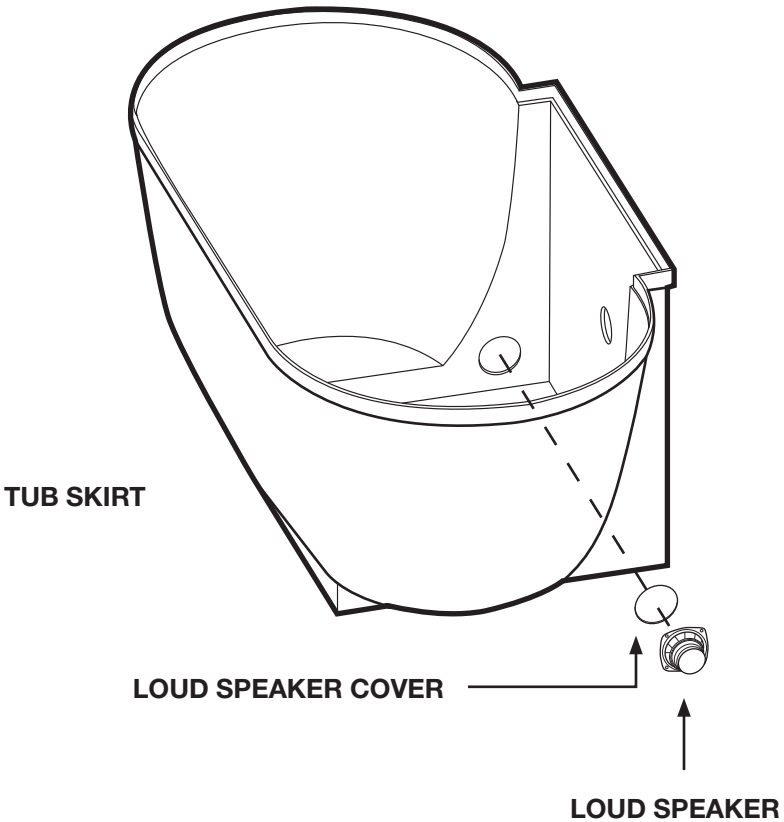

ARIEL

ARIEL AM128JDCLZ

Shower Head & Faucet Assembly

Connect the shower head wand hose (shower head pipe) to the 3-way selector valve.

Refer to Page 12 for more information.

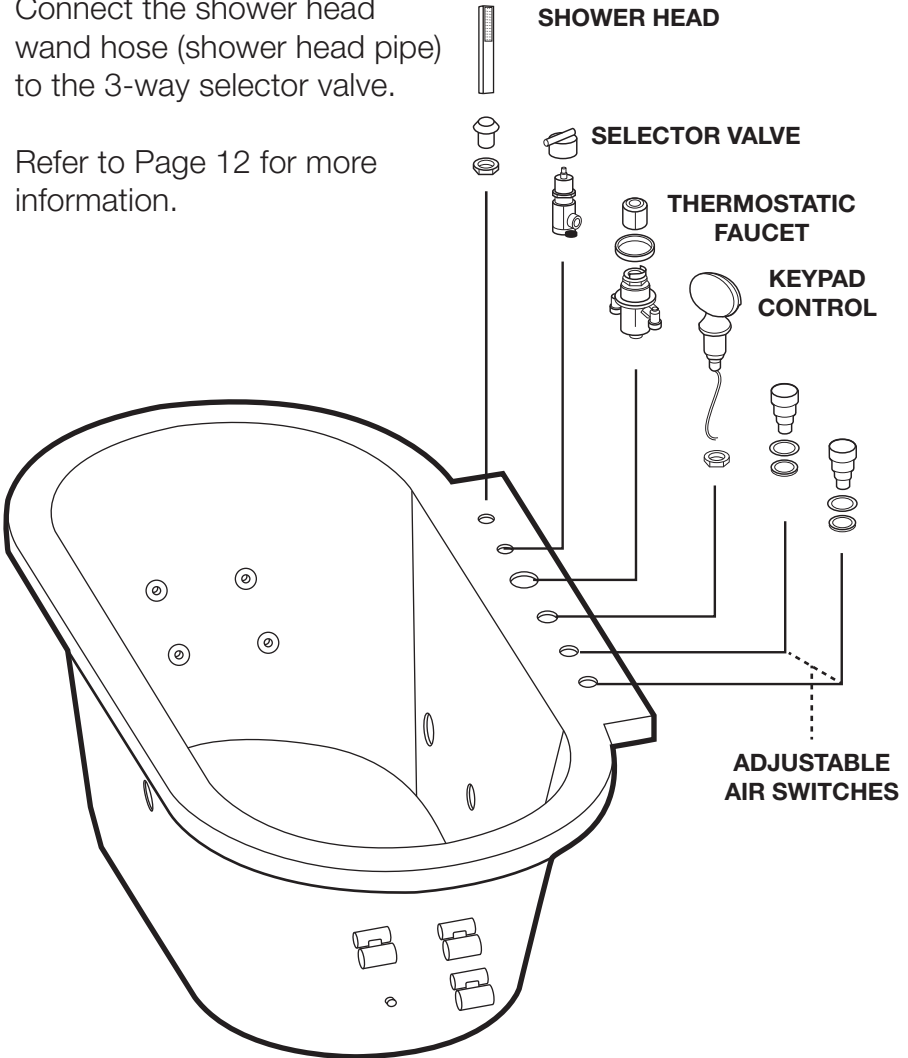

INSTALLATION MANUAL

ARIEL AM128JDCLZ

Drain Assembly

ARIEL

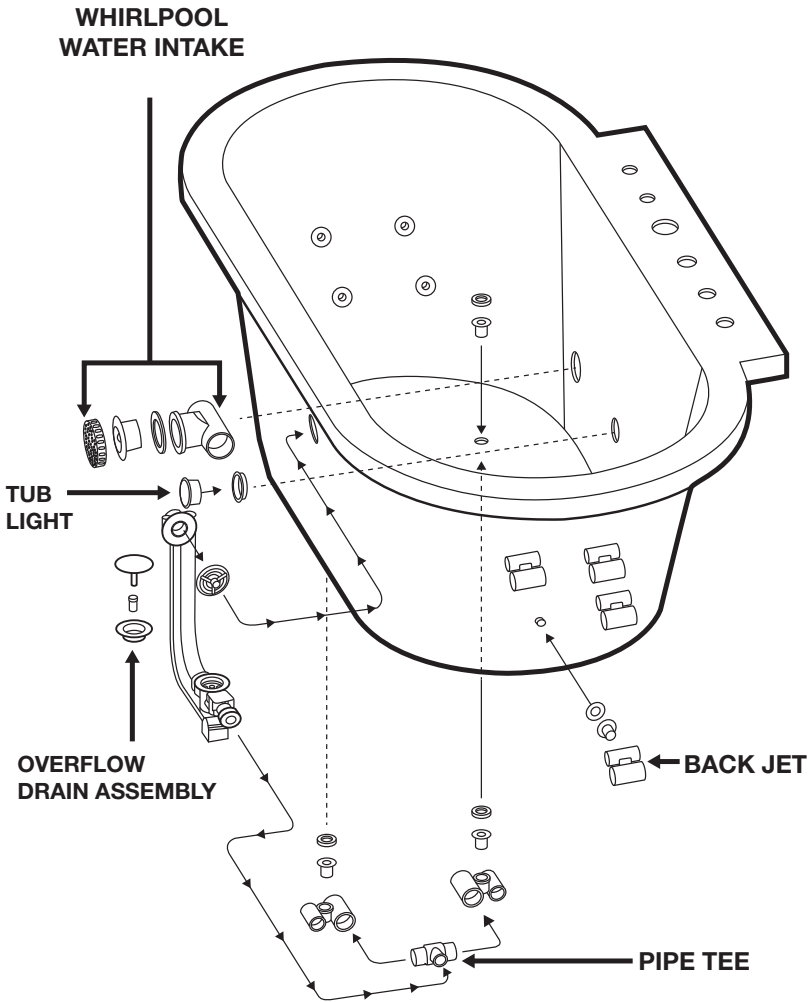

ARIEL

ARIEL AM128JDCLZ

Chassis & Water Pump Assembly

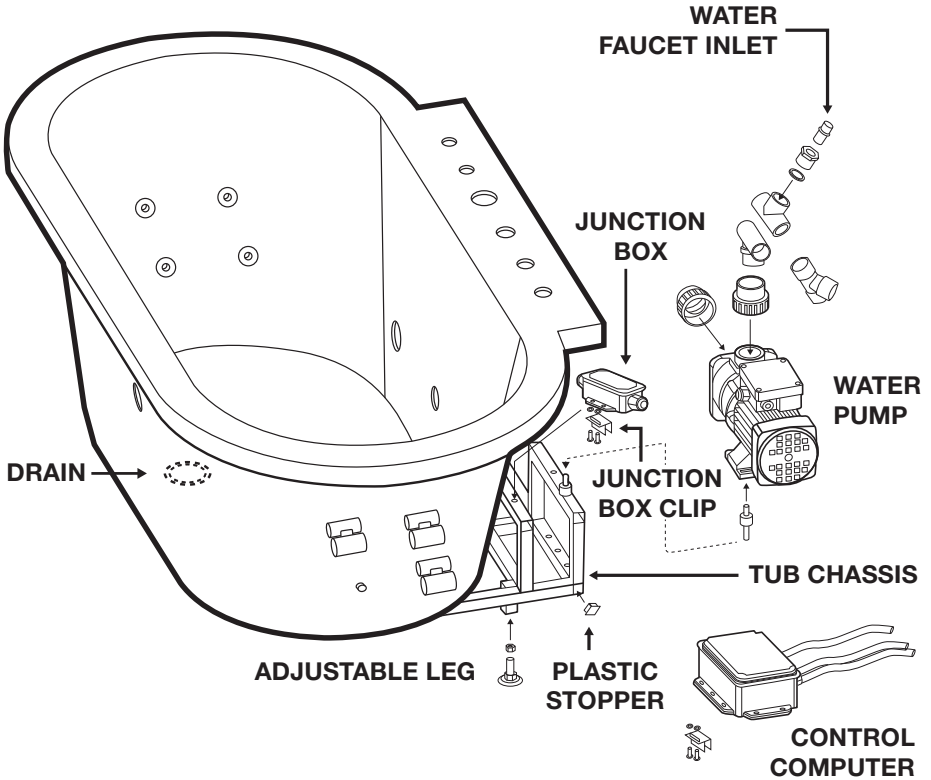

DRAIN

The drain “Gas Trap” is located under the tub and can be turned in any direction as desired. You will need to connect the flexible drain hose from the gas trap to the house drain.

Note: Make sure that the drain hose slopes evenly from the gas trap to the house drain. The drain may require a test to insure the water flow is constant and that there is no leakage.

ARIEL AM128JDCLZ

Faucet Assembly

ARIEL

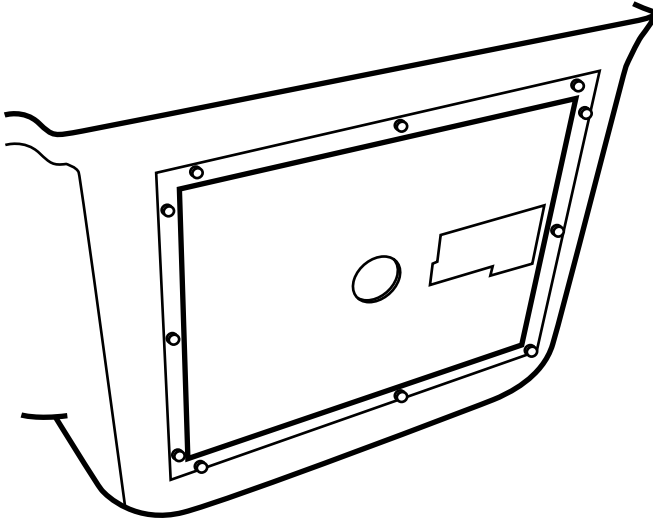

FIGURE A

WATER SUPPLY

In order to install the plumbing of your new ARIEL bath tub you will need access through the back panel. Remove the back panel as shown in **Figure A** to expose the plumbing and electrical of the tub.

The faucet assembly that comes with your new ARIEL Bath tub will have selected hoses attached. Please refer to **Figure B** to insure accuracy and to make any changes if necessary.

You will need water supply lines from your home to the thermostatic valve of your new ARIEL bathtub. 1/2" FPT (female pipe thread) steel braided hoses or equivalent strength are required.

Attach the water supply lines from the main water supply. You may need to run the hoses through the center hole of the back panel before connecting them to the water inlets of the faucet assembly. Insure that each hose on the water faucets system is tight and free of leaks. Test for leaks before first use.

ARIEL

ARIEL AM128JDCLZ
Faucet Assembly

FIGURE B

SHOWER WAND

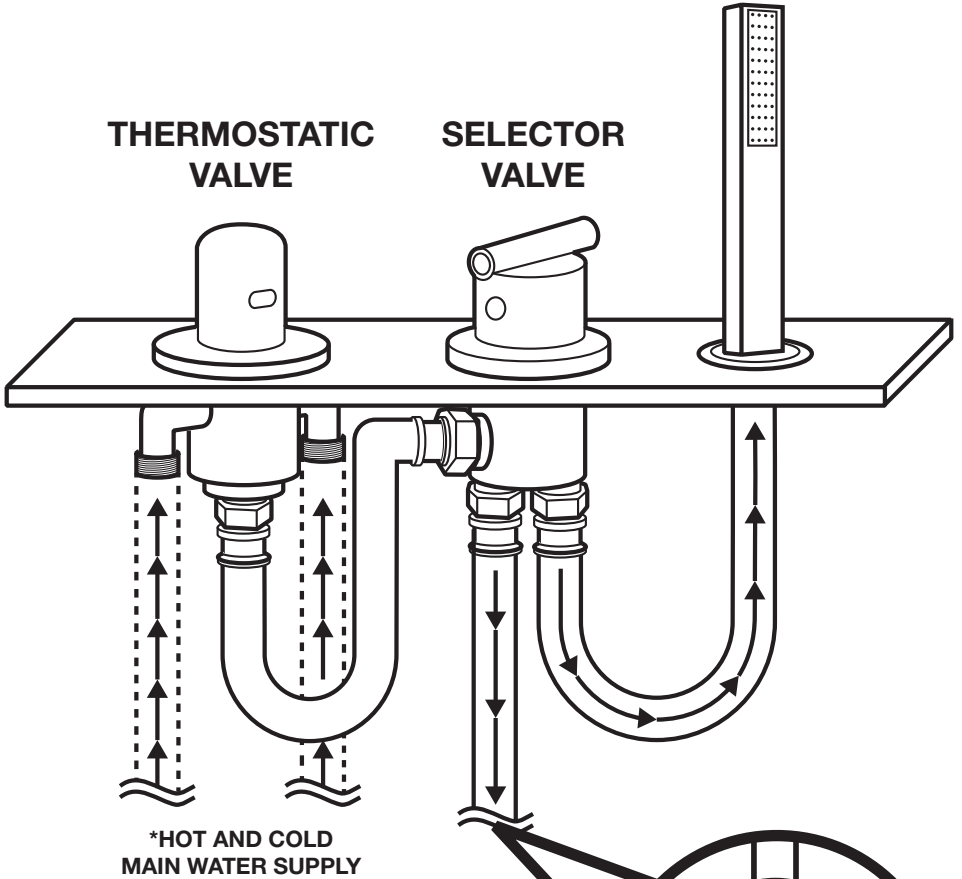

***HOT AND COLD
MAIN WATER SUPPLY**

* Main water supply hoses not included.

** Position of parts may vary from diagram. Tub filler inlet may already be connected by factory.

****TO TUB FILLER
INLET**

INSTALLATION MANUAL

ARIEL AM128JDCLZ

Power Supply Assembly

ARIEL

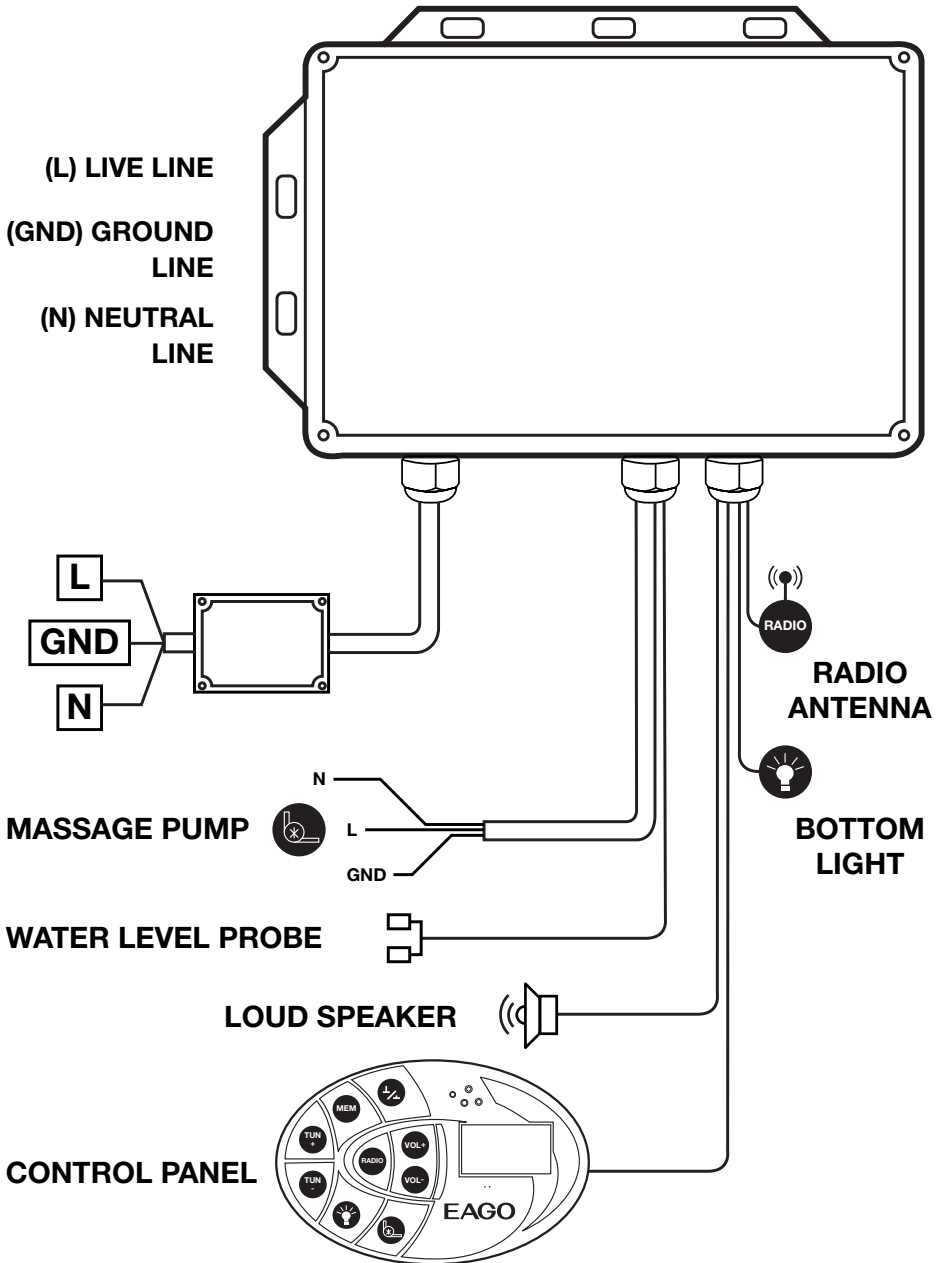

ELECTRICAL

Connect all electrical plugs from the computer box to their corresponding plugs. Some plugs may already be connected. Check the connections by unplugging and reconnecting them. They will be either color coordinated, marked with matching icons, or have matching descriptions. After all the electrical connections have been thoroughly checked, temporarily supply electrical service to the unit and test the computer system functions after you and/or your certified contractor have confirmed it is safe to do so. Please see the diagram below.

Parameter	Massage Pump	Bottom Light	Thermostatic	Electromagnetic Valve	Speaker
Rating Voltage	AC110-120V/60Hz	DC12V	DC12V	AC120V/60Hz	
Rating Power	1500W	3W	5W		15W

A 20 AMP GFCI BREAKER IS RECOMMENDED FOR THE TUB

FINISHING TOUCHES

After testing the water lines for any leakage, set the tub in its final resting place for the last time.

Make sure that the inside of the tub is rinsed clean. Close the tub drain and start filling it with water.

Note: In order for the water pump to work correctly, the water level will have to be all the way up to the over flow drain/knob.

Once the tub is full you may turn on the computer system using the keypad control. Refer to the next section to view the keypad operations.

ARIEL AM128JDCLZ

Keypad Control Instructions

ARIEL

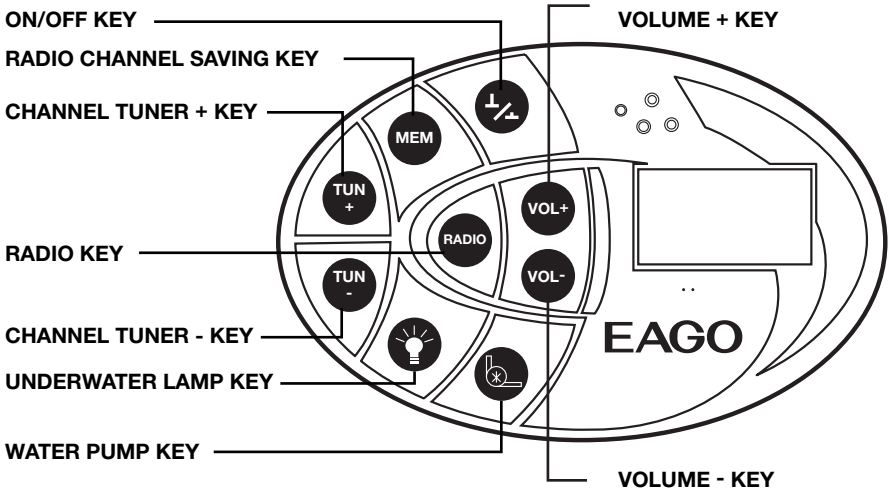

POWER FUNCTION

Press  to Power on the system. Press again to turn it off. By default, the system will shut off automatically after 60 minutes. The steam room will shut down in 30 minutes automatically.

CHANNELS



Press  to turn on the radio.

Press  to shift higher in radio frequencies.

Press  to shift to lower radio frequencies.

Press  to turn off the radio.

VOLUME

After the radio has been turned on, press the  button to raise the volume. Press the  button to lower the volume.

MEMORY

Press  to select the channel saving function.

Pressing the  button will reset the channel.

Hold the  button to save the channel in memory.

TUB LIGHT

Press the  button to run on the light. Water does not have to be in the tub. Each time the light button is pressed, it will switch to a different color until it cycles off.

WATER MASSAGE

Press the  button to turn the water massage jets on or off.

Note: If the water level is not high enough the jets will not turn on.

ARIEL AM128JDCLZ

Water Faucet Control Usage

ARIEL

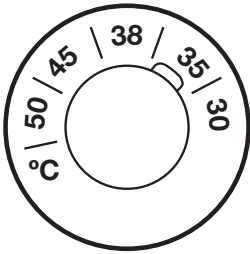

**SHOWER
HEAD**

A

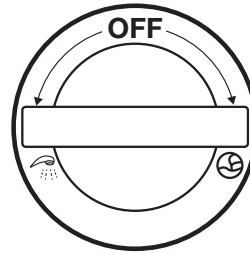

TUB FILLER

B

FAUCET USAGE

The thermostatic valve will adjust your hot and cold water. The water inlets will be labeled on the underside of the valve by color. Red will indicate hot. Blue will indicate cold.

This selector valve will allow you to choose the function desired. You may choose between shower head, tub filler and off.



Q. How does the AM128JDCLZ fill up?

A. The AM128JDCLZ fills via jet system.

Q. Does the AM128JDCLZ have a faucet?

A. No, the AM128JDCLZ is equipped with a handheld wand.

Q. Does the AM128JDCLZ come with a heat pump or can a heat pump be added?

A. The AM128JDCLZ does not contain a heat pump nor can it be equipped with a heat pump.

Q. What is the voltage rating of the AM128JDCLZ?

A. The AM128JDCLZ runs at 110V/20 amps through the recommended use of a GFCI breaker.

ARIEL AM128JDCLZ

Warranty Information

ARIEL

WARRANTY COVERAGE

Atlas International, Inc. (the “Company”) offers the following express limited warranty to the original purchaser of any Atlas International, Inc. Steam Shower system, or Steam Shower product (“unit”) who purchases the product for personal or single family use (“user”). The Company will repair or replace, at its discretion, the unit or its components in accordance with the following terms and conditions. Units in commercial use are excluded from any warranty coverage whatsoever. This limited warranty is non-transferable and is solely issued to the original purchaser.

TEN YEAR LIMITED WARRANTY ON STRUCTURAL COMPONENTS OF STEAM SHOWER SYSTEM

Our limited warranty on Steam Shower products is for ten (10) years. Our warranty covers parts only, including factory-supplied components (e.g., acrylic panels, alloy frames or panels, etc.) against defects in material or workmanship, but does not cover glass/mirror panels, associated labor for repairs or replacements, contractor’s charges for time, removal, reinstallation, consequential damages, glass or acrylic due to negligence or misuse, transportation, or freight charges. Warranty coverage begins on the date the unit was originally purchased by the user.

ONE YEAR LIMITED WARRANTY ON COMPONENTS & HARDWARE OF STEAM SHOWER SYSTEM

Our limited warranty on Steam Shower products is for one (1) year. Our warranty covers parts only, including factory-installed components (e.g., glass/mirror panels, pump, motor, generator, valves, etc.) against defects in material or workmanship, but does not cover associated labor for repairs or replacements, contractor’s charges for time, removal, reinstallation, consequential damages, glass or acrylic due to negligence or misuse, transportation, or freight charges. Warranty coverage begins on the date the unit was originally purchased by the user.

NINETY DAY LIMITED WARRANTY ON OPTIONS AND ACCESSORIES (REPLACEMENT PARTS)

Our limited warranty on the manufacturer’s options and accessories sold by the Company is for ninety (90) days for parts only. Our warranty covers the manufacturer’s options and accessories sold by the Company (e.g., fill spout kits, jets, rainfall showerhead, fittings, accessories, steam generator, keypads, etc) against defects in material or workmanship, but does not cover associated labor for repairs or replacements, contractor’s charges for time, removal, reinstallation, consequential damages, glass or acrylic due to negligence or misuse, transportation, or freight charges. Warranty coverage begins on the date the option

ARIEL**ARIEL AM128JDCLZ**
Warranty Information

or accessory was originally purchased by the user.

THIRTY DAY LIMITED WARRANTY ON LIGHT BULBS, ROOF LAMPS, & CONSUMABLE GOODS

Our limited warranty on the manufacturer's light bulbs, roof lamps, or other consumable goods, sold by the Company is for thirty (30) days. Our warranty covers the manufacturer's light bulbs, roof lamps, and other consumable goods sold by the Company against defects in material or workmanship, but does not cover associated labor for repairs or replacements, contractor's charges for time, removal, reinstallation, consequential damages, glass or acrylic due to negligence or misuse, transportation, or freight charges. Warranty coverage begins on the date the light bulbs and roof lamps were originally purchased by the user.

WARRANTY LIMITATIONS

Your Atlas Steam Shower will remain beautiful for many years if you take care of it. Some waterproofing strips and other seals or gaskets may need to be replaced when they show signs of wear, yellowing, or are not watertight. Refer to the parts list of your manual for all seals. Water conditions in various parts of the country will determine any extra cleaning attention you may have to give your new Steam Shower system. Atlas does not recommend the use of harsh chemical cleansers or abrasive instrument/cleaners on any of its products, as these cleaning methods can damage the finishes on the product and will default warranty coverage.

Our limited warranty does not cover defects, damage, or failures caused by the common carrier, installer, user, or other person, or resulting from, without limitation, any of the following: careless handling (impacts, dropping the unit abruptly, lifting unit by plumbing, abrading the finish, etc.); modification of any type for any reason (including modification to meet local codes); improper installation (including installation not in accordance with instructions and specifications provided with the unit and/or on updated notices on the company's website www.atlasusa.net; connections supplied by the installer of the equipment; improper voltage supply or unauthorized electrical modification; misuse; incorrect operation, or lack of proper routine maintenance (every 10-30 hours of usage); operation of the unit without specified minimum amount of water or at inappropriate water temperatures; use of abrasive or improper cleaners; or acts of God, such as lightning, floods, earthquakes, etc.

Prior to installation user should check electrical specification of the product they have received. Electrical specifications can be found on the electrical components attached to the back of the unit; or contact your place of purchase for more

ARIEL AM128JDCLZ

Warranty Information



detailed information.

In addition, THE COMPANY WILL NOT BE RESPONSIBLE FOR INCIDENTAL OR CONSEQUENTIAL DAMAGES or losses arising from any cause (e.g., water damage to carpet, ceiling, loss of use, etc.) including its own negligence; damages to, respecting, or resulting from: plated parts when chemicals are used in the unit; optional equipment not manufactured by the Company but supplied by Dealer, installer or the Company; the unit's prior usage as an operational display; or defects that should have been discovered before installation. This limited warranty does not include: labor, transportation, or other costs incurred in the removal and/or reinstallation of the original unit and/or installation of a replacement unit; any costs relating to obtaining access for repair; or loss of use damage, including loss of sales, profit or business advantage of any kind under any circumstances. Units in commercial use are excluded from any warranty coverage whatsoever.

Warranty coverage is provided only in the United States of America and Canada. EXCLUSION OF IMPLIED WARRANTIES IMPLIED WARRANTIES OF MERCHANTABILITY AND FITNESS FOR A PARTICULAR PURPOSE ARE DISCLAIMED ALTOGETHER OR TO THE FULL EXTENT ALLOWED BY LAW.

NOTICE: This warranty gives you specific legal rights, and you may also have other rights which vary from state to state. There are no warranties applicable to Atlas International, Inc. products except as expressly stated herein or as implied by applicable state and federal laws. The Company will not be responsible for any statements or representations made in any form that go beyond, are broader than or are inconsistent with any authorized literature or specifications furnished by the Company.

Some states do not allow limitations on how long an implied warranty lasts, or the exclusion or limitation of incidental or consequential damages, so the above limitations and exclusions may not apply to you.

RETURN OF WARRANTY CARD

The attached pre-addressed Warranty Registration Card **MUST** be filled out by the purchaser within thirty (30) days from purchase and mailed to Atlas International, Inc. in order for this warranty to become effective.

Atlas International, Inc.
500 West Warner Avenue, Suite A
Santa Ana, CA 92707

RESPONSIBILITIES OF OTHERS

Inspecting the unit prior to installation is the responsibility of the user, installer, building contractor, or consignee who acts on behalf of the user. They are responsible for ensuring the unit is free of defect or damage. Notices are placed on and in the unit and on the shipping carton advising the installer of this responsibility. In the event of a problem, the unit must not be installed. The Company is not responsible for failures or damage that could have been discovered, repaired, or avoided by proper inspection and testing prior to installation.

Damage occurring in transit is the responsibility of the carrier. The user, installer, or consignee **MUST** open the crates and inspect the unit for damage when it is delivered. Your signature on the "Proof of Delivery" (P.O.D) of a shipment, without any other notation otherwise, means you are incurring the full responsibility of the shipment in "good" condition. If damage is discovered, it must be reported on the P.O.D. note at delivery. If damaged is discovered after delivery, it must be reported **WITHIN 72 HOURS** to the seller and the carrier in writing, and an inspection requested. Failure of the carrier to respond should be reported to the seller and the management of carrier service. Your freight claims should be filed promptly thereafter.

It is the responsibility of the installer, building contractor, or user to provide access for service. The Company is not responsible for any costs relating to obtaining access for repair. The user shall bear such costs and, if appropriate, must seek recovery from the installer.

Damage occurring to the unit during installation is the responsibility of the installer and/or building contractor and damage occurring thereafter is the responsibility of the user.

Failure of any optional equipment is the sole responsibility of the equipment manufacturer. Options and accessories, manufactured by the Company, sold separately from original purchase of the unit, outside of the original limited warranty, are warranted for ninety (90) days from the original date of purchase for parts only.

The user and/or contractor is responsible for knowing/checking local code requirements and notifying the installing contractor and/or user of these requirements at the time of purchase. The Company is not responsible for costs to modify any product to obtain any code approval, such as city, county, or state building codes in U.S.A. or municipal or provincial codes in Canada.

ARIEL AM128JDCLZ

Warranty Information

ARIEL

WARRANTY SERVICE

The Company will provide a defective component or part if the following conditions have been met: the failure is of the nature or type covered by the warranty; the user has informed an authorized Atlas International, Inc. service agent or Warranty Service Department representative of the nature of the problem during the warranty period; conclusive evidence (e.g., proof of purchase and/or proper installation) is provided to the foregoing by the user proving that the failure occurred or was discovered within the warranty period.

In order to obtain warranty on the defective unit component or part, contact Atlas International, Inc at the phone number below. You may need to provide a description of the problem and proof of purchase. You will be instructed how to obtain replacements and where to return, at your expense, the failed component(s), option(s), or accessory(ies).

To obtain warranty replacement for factory-installed components or Company supplied options and accessories manufactured and supplied by the Company, call or write to:

Atlas International, Inc.
Warranty Service Department
500 West Warner Avenue, Suite A
Santa Ana, CA 92707
(714) 622-1550

PRIOR TO SENDING ANYTHING IN THE MAIL, please call an Atlas representative to obtain a Return of Merchandise Authorization (RMA) number for the user's return package; otherwise, the user's package may be rejected and sent back at user's expense.

All replacement parts and/or equipment shall resume the original warranty from the date of purchase. Defective parts must be returned to the manufacture. Failure to do so will result in default in warranty and/or additional charges.

ARIEL

ARIEL AM128JDCLZ

Warranty Information

WARRANTY REGISTRATION CARD

One Year Limited Warranty on Steam Shower or Shower Panel Product(s), or
Ninety Day Limited Warranty on Options and Accessories (Replacement Parts)

This card must be filled out and returned to the address printed on the other side within thirty (30) days from date of purchase in order for this warranty to become effective.

Purchaser's Name _____

Purchaser's Address _____

City _____ *State _____ *Zip _____

Date of Purchase _____

Model Name _____

Serial Number _____

Dealer's Name & Dealer's Address _____

1. How did you first hear about this Atlas® product?

- | | |
|---|---|
| <input type="checkbox"/> Advertisement | <input type="checkbox"/> Builder/Plumber/Remodeler |
| <input type="checkbox"/> Article in Magazine/Newspaper | <input type="checkbox"/> Decorator/Architect |
| <input type="checkbox"/> Visited Dealer/Plumbing Supplier | <input type="checkbox"/> Visited Retailer/Home Center Store |
| <input type="checkbox"/> Yellow Pages | <input type="checkbox"/> Word of Mouth - Friend/Relative/Acquaintance |
| <input type="checkbox"/> Other | |

2. Who first gave you specific information about this product (specifications, prices, etc.)?

- | | |
|--|---|
| <input type="checkbox"/> Dealer/Plumber Supplier | <input type="checkbox"/> Plumbing Contractor |
| <input type="checkbox"/> Builder | <input type="checkbox"/> Retailer/Home Center Store |
| <input type="checkbox"/> Remodeler | <input type="checkbox"/> Decorator/Architect |
| <input type="checkbox"/> Already Installed | |

3. What was the main reason for purchase?

- | | |
|---|---------------------------------------|
| <input type="checkbox"/> Styling | <input type="checkbox"/> Price |
| <input type="checkbox"/> Warranty Service | <input type="checkbox"/> Hydrotherapy |
| <input type="checkbox"/> Product Features | <input type="checkbox"/> Home Resale |
| <input type="checkbox"/> Brand Name | <input type="checkbox"/> Other |

ARIEL AM128JDCLZ

Warranty Information



4. Who finally decided which product you would buy?

- | | |
|---|--|
| <input type="checkbox"/> Self | <input type="checkbox"/> Designer/Architect |
| <input type="checkbox"/> Spouse | <input type="checkbox"/> Builder/Plumber/Remodeler |
| <input type="checkbox"/> Self and Spouse Together | <input type="checkbox"/> Already Installed |
| <input type="checkbox"/> Other Family Member | |

5. Who installed?

- | | |
|---|--|
| <input type="checkbox"/> Already installed/New Home | <input type="checkbox"/> Self/Spouse when remodeling |
| <input type="checkbox"/> Contractor/Plumber when remodeling | <input type="checkbox"/> Other |

6. What is the current market value of this property?

Please estimate \$ _____

7. What is the age of the head of the household? _____ years

8. How long did you shop before purchasing unit?

- | | |
|--|--|
| <input type="checkbox"/> 1 day | <input type="checkbox"/> 1 month-2 months |
| <input type="checkbox"/> 2-7 days | <input type="checkbox"/> 2 months-6 months |
| <input type="checkbox"/> 1 week-2 weeks | <input type="checkbox"/> 6 months-1 year |
| <input type="checkbox"/> 2 weeks-4 weeks | <input type="checkbox"/> 1 year-2 years |
| | <input type="checkbox"/> +2 years |

9. Approximately how long have you lived in this home _____ years

10. Please indicate, approximately, the total annual income of your household.

- | | |
|---|---|
| <input type="checkbox"/> Up to \$24,999 | <input type="checkbox"/> \$50,000 to \$74,999 |
| <input type="checkbox"/> \$25,000 to \$29,999 | <input type="checkbox"/> \$75,000 to \$99,999 |
| <input type="checkbox"/> \$30,000 to \$39,999 | <input type="checkbox"/> \$100,000 to \$149,999 |
| <input type="checkbox"/> \$40,000 to \$49,999 | <input type="checkbox"/> \$150,000 and Above |

11. Was your purchase process?

- | | |
|------------------------------------|---|
| <input type="checkbox"/> Very easy | <input type="checkbox"/> Difficult |
| <input type="checkbox"/> Easy | <input type="checkbox"/> Very Difficult |

