



Board Mount Airflow Sensor Platform

User Guide

DEGREE CONTROLS, INCORPORATED
18 Meadowbrook Drive
Milford, New Hampshire 03055 USA



Degree Controls, Inc. © Copyright 2018, all rights reserved.
Information in this document is subject to change without notice.
Windows® is a registered trademark of Microsoft Corporation • All other trademarks are property of their respective owners.

Table of Contents

General Information	3
1.1.1 Mechanical Features.....	3
1.1 Features.....	3
1.1.2 Electrical & Performance Features	3
1.2 Common Applications	3
2 Product Specifications	4
2.1 F660/F662: Tall Profile	4
2.1.1 General Specifications	4
2.1.2 Pin Assignment & Descriptions.....	4
2.1.3 F660/F662: Mechanical Dimensions.....	4
2.2 F661/F663: Low Profile.....	5
2.2.1 General Specifications	5
2.2.2 Pin Assignment & Descriptions.....	5
2.2.3 F661/F663: Mechanical Dimensions.....	5
2.3 RFS300: Reference Design	6
2.3.1 General Specifications	6
2.3.2 Pin Assignment & Descriptions.....	6
2.3.3 RFS300: Mechanical Dimensions.....	6
2.4 Performance Rating & Accuracy.....	7
3 Installation Procedure	7
3.1 Surface Mount Socketed Install.....	7
3.2 RoHs-Compliant No-Wash Solder.....	7
3.3 Special Mechanical Requirements Requiring Adhesive.....	11
4 Communication	11
4.1 UART Communication	11
4.1.1 Hardware	11
4.1.2 Configuration	12
4.1.3 Protocol	12
4.1.4 Password Protection.....	12
4.1.5 Alarm Configuration	13
4.2 I ² C Communication	13
4.2.1 I ² C Communication Protocols.....	13
4.2.2 I ² C Command Restrictions	14
4.2.3 I ² C Address.....	14
4.2.4 Password Protection.....	15
4.2.5 Alarm Configuration	15
5 Sensor Registers	15
5.1 F660/F662 and F661/F663	15
5.2 RFS300.....	17
6 Degree Controls Inc. Product Warranty	19

General Information

Thank you for your purchase of a DegreeC Board Mount Air Velocity Sensor Product. Our award-winning board-mount platform is the only fully calibrated, digital air velocity and temperature sensor on the market designed specifically for monitoring and managing airflow and thermal conditions on the PCB. To account for variable board densities, component layouts, operating conditions, and manufacturing volumes, our three sensor models, the F660/F662 (vertical flow profile), the F661/F663 (horizontal flow profile), and our reference design option, the RFS300, utilize a minimal airflow impedance architecture to measure on-board air velocities and temperatures without disrupting the ambient flow profile. With robust digital communication capabilities in UART or I²C styles, our sensors can be designed-in to your board as a control, alarm or monitoring system.



The F660/F662, F661/F663, and RFS300 sensors can be utilized to reliably perform critical environmental sweeps with the highest precision and repeatability ever achieved with a board-mount air velocity sensor.

1.1 Features

1.1.1 Mechanical Features

- 3 mechanical designs to accommodate board density variability and implementation constraints
- Smallest footprint air velocity sensor available
- Optimized for high performance, dense form-factor boards
- Dual sensing element with protective shroud
- Horizontal or vertical flow profile options
- Corrosion-resistant nylon shell
- RoHS compliant

1.1.2 Electrical & Performance Features

- Up to 5% accuracy and repeatability
- <20mA consumption
- Provides fully linearized air velocity and air temperature with wide operating range
- UART or I²C communication
- Alarm output option for switch operation
- I²C addressing for multipoint measurement
- Available flow learning command for accuracy optimization, post-soldering

1.2 Common Applications

Where real-time air velocity and temperature measurement is required at the board level:

- Environmental sweeps
- Detecting airflow blockage
- Detecting fan fail
- Cooling coil performance
- Heatsink cooling
- DC-DC converter cooling
- Flow uniformity monitoring
- Thermal rise assessment
- Mass airflow calculations

2 Product Specifications

2.1 F660/F662: Tall Profile

2.1.1 General Specifications



Operating Temperature	0°C to 60°C (32°F to 140°F)
Storage Temperature	40°C to 105°C (-40°F - 221°F)
Relative Humidity	5 – 95% (non-condensing)
Response Time	400 ms
Output	Configurable trip point
Communications	3.3V I ² C (400KHz) or 3.3VDC UART
Housing Material	Nylon UL94-V0
F662	
Operating Voltage	4.5 – 13 VDC
F660	
Recommended Operating Voltage	15 – 18 VDC
Maximum Operating Voltage	12 – 24 VDC*
Resolution	0.1°C

*Input voltages below 15 VDC may result in limited operation at lower temperatures or higher flow rates. Input voltages above 18 VDC may result in decreased accuracy.

2.1.2 Pin Assignment & Descriptions

Pin	Description
1	Input Voltage Return (Gnd)
2	UART RX or I ² C SDA
3	Not Used
4	Address / Alarm
5	UART TX or I ² C SCL
6	Input Voltage

2.1.3 F660/F662: Mechanical Dimensions

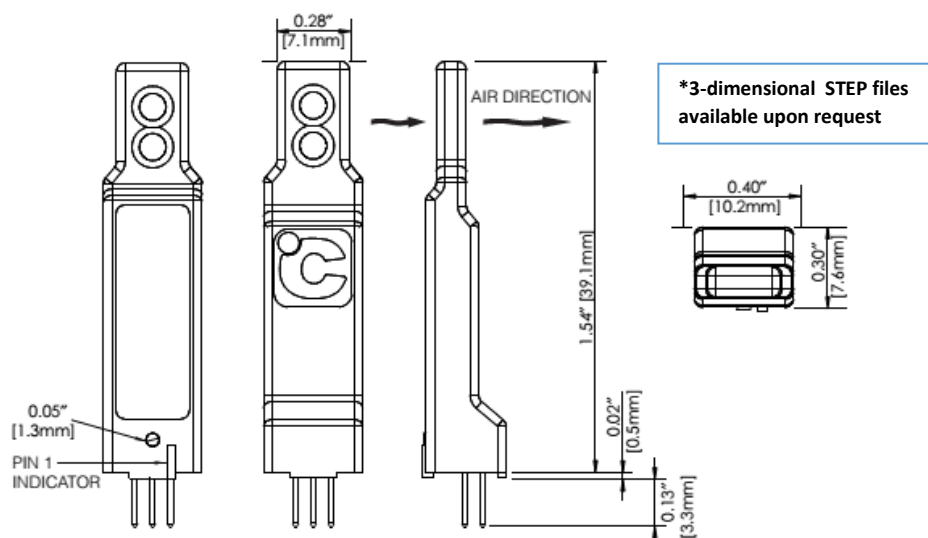

2.2 F661/F663: Low Profile

2.2.1 General Specifications

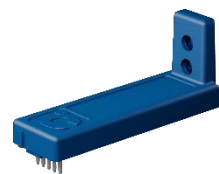

Operating Temperature	0°C to 60°C (32°F to 140°F)
Storage Temperature	40°C to 105°C (-40°F - 220°F)
Relative Humidity	5 – 95% (non-condensing)
Response Time	400 ms
Output	Configurable trip point
Communications	3.3V I ² C (400KHz) or 3.3VDC UART
Housing Material	Nylon UL94-V0
F663	
Operating Voltage	4.5 – 13 VDC
F661	
Recommended Operating Voltage	15 – 18 VDC
Maximum Operating Voltage	12 – 24 VDC*
Resolution	0.1°C

*Input voltages below 15 VDC may result in limited operation at lower temperatures or higher flow rates. Input voltages above 18 VDC may result in decreased accuracy.

2.2.2 Pin Assignment & Descriptions

Pin	Description
1	Input Voltage Return (Gnd)
2	UART RX or I ² C SDA
3	Address / Alarm
4	UART TX or I ² C SCL
5	Input Voltage

2.2.3 F661/F663: Mechanical Dimensions

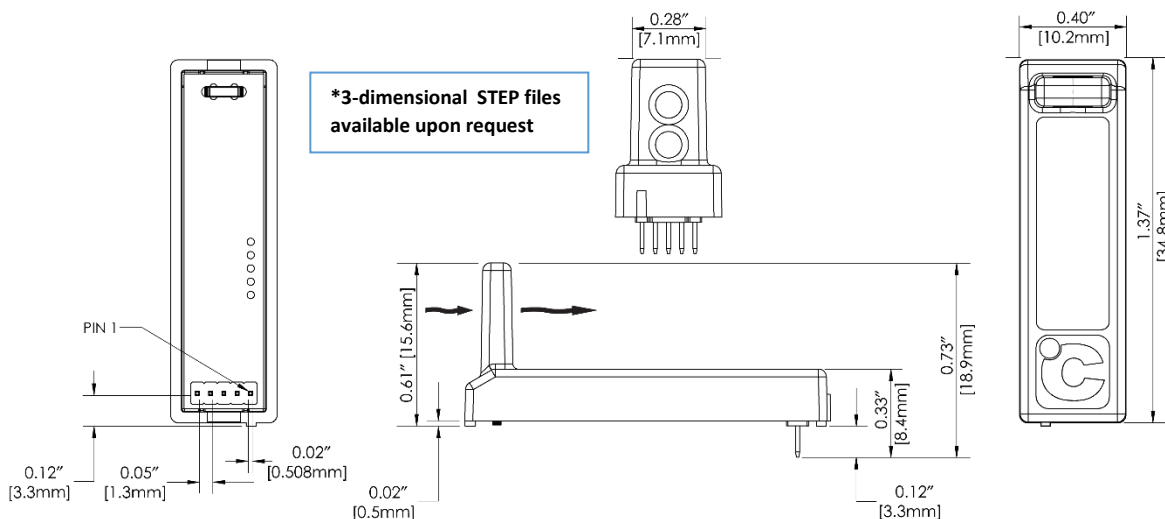

2.3 RFS300: Reference Design

The RFS300 is a reference design air velocity and temperature sensor best suited for higher volume customers with a need for more versatility. The electronic circuit is implemented directly on the client's PCB assembly, and Degree Controls provides the sensing head and the programmed micro-processor, on tape or reel, ready for reflow or soldering. Specifications are detailed below.

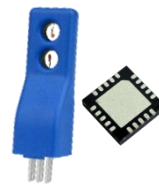

2.3.1 General Specifications

Operating Temperature	0°C to 60°C (32°F to 140°F)
Storage Temperature	-40°C to 85°C (-40°F - 185°F)
Relative Humidity	5 – 95% (non-condensing)
Response Time	400 ms
Output	Open drain, Configurable trip point
Communications	I ² C (400KHz) or 3.3VDC UART
Housing Material	Nylon, 94-V0
Operating Voltage	4.5 – 13 VDC
Resolution	0.1°C

2.3.2 Pin Assignment & Descriptions

Pin	Assignment	Description
1	Flow Therm Hi	Velocity High
2	Flow Therm Lo	Velocity Low
3	Tamb In	Temp High
4	SCIO	Serial IO
5	Gnd	Temp Low
6	+3.3 VDC	Serial Drive

2.3.3 RFS300: Mechanical Dimensions

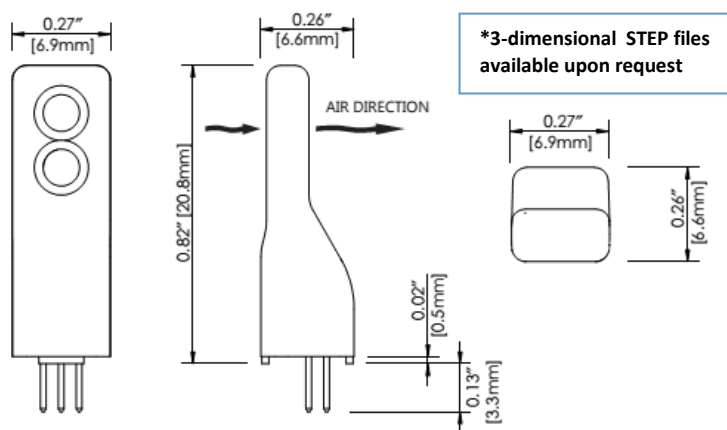

2.4 Performance Rating & Accuracy

Temperature Compensation: The F660/F662, F661/F663, and RFS300 utilize a thermal airflow sensor; it is sensitive to changes in air density and indicates velocity with reference to a set of standard conditions (21°C (70°F), 760mmHg (101.325kPa), and 0%RH). These sensors have been designed so that when used over the stated temperature compensation range, the sensor indicates very close to actual air velocity and minimal compensation is only required to account for changes in barometric pressure or altitude.

Air Velocity Range	Air Velocity Accuracy (within compensation range)
0.15 to 1.0 m/s (30 to 200 fpm)	± (5% of reading + 0.04 m/s [8 fpm])
0.5 to 10 m/s (100 to 2,000 fpm)	± (5% of reading + 0.10 m/s [20 fpm])
1.0 to 20 m/s (200 to 4,000 fpm)	± (5% of reading + 0.15 m/s [30 fpm])

Repeatability of ±1% of reading (under identical conditions)

Air Temperature Measurement Accuracy: ±2°C (3.6°F)

Note: The RFS300 sensor utilizes a different air velocity range, accuracy, and repeatability:

Air Velocity Range	Air Velocity Accuracy (within compensation range)
0.15 to 20 m/s (30 to 4,000 fpm)	± (5% of reading + 0.10 m/s [20 fpm])

Repeatability of ±2% of reading (under identical conditions)

3 Installation Procedure

DegreeC Board Mount Sensor products (F660/F662, F661/F663, and RFS300) can be mounted onto a PCB assembly by way of a simple socket insertion procedure or a no-clean soldering process.

3.1 Surface Mount Socketed Install

1. Insert sensor pins into corresponding mounting sockets on printed circuit board as depicted below.

3.2 RoHs-Compliant No-Wash Solder

1. Before soldering a F660/F662, F661/F663, or RFS300 sensor directly onto your circuit board surface, we advise you to follow best practices (ANSI/J-STD-001) during layout and processing to ensure optimal performance. Given the design of the nylon housing utilized in our board-mount sensors, DegreeC sensors must be soldered using a no-clean solder process to prevent damage to sensor electronics.
2. In all instances, the soldering iron temperature must not exceed 480°F.
3. If no-clean solder process is not used, install the sensor after board wash, and hand clean.
4. For proper device soldering, please consult the following mechanical drawings and the previous section for recommended drill diameter, pitch, and silk screen outline dimensions. Silk screen outline and Pin 1 should be marked as indicated.

F660/F662: Drill Diagram

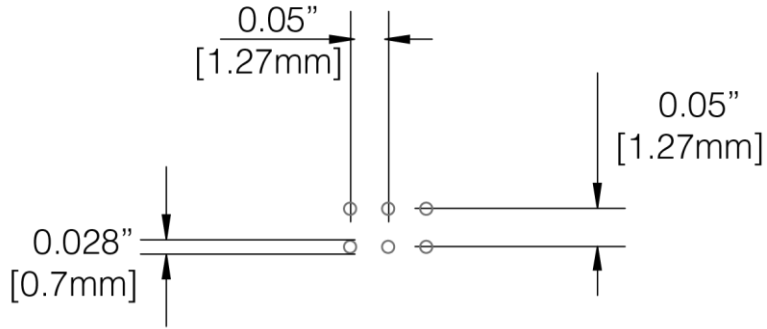

F660/F662: Silk Screen Outline

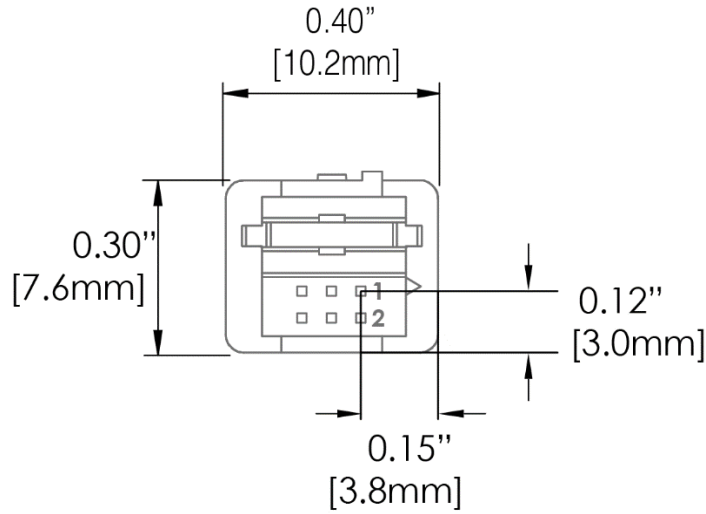

F661/F663: Drill Diagram

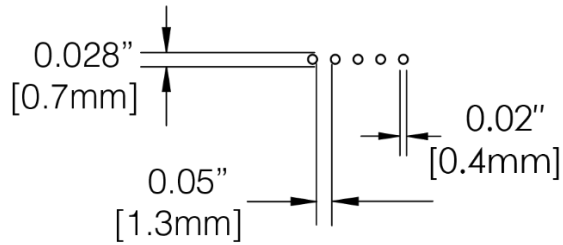

F661/F663: Silk Screen Outline

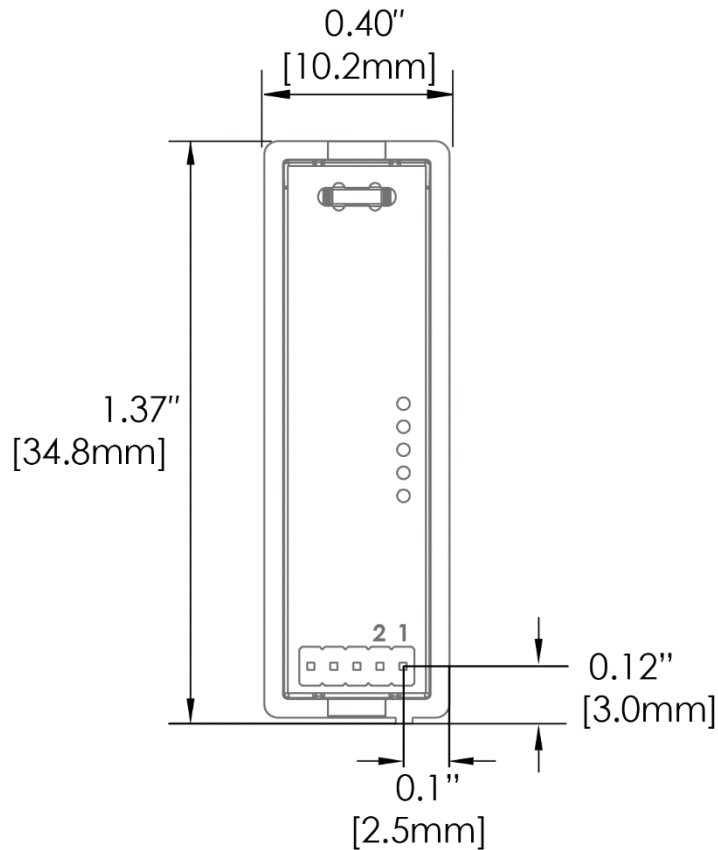

RFS300: Drill Diagram

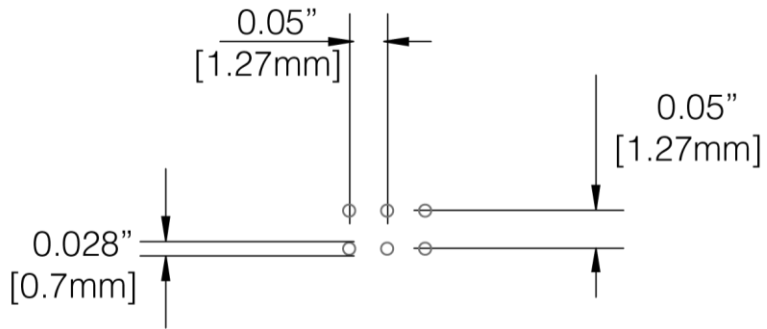

RFS300: Silk Screen Outline

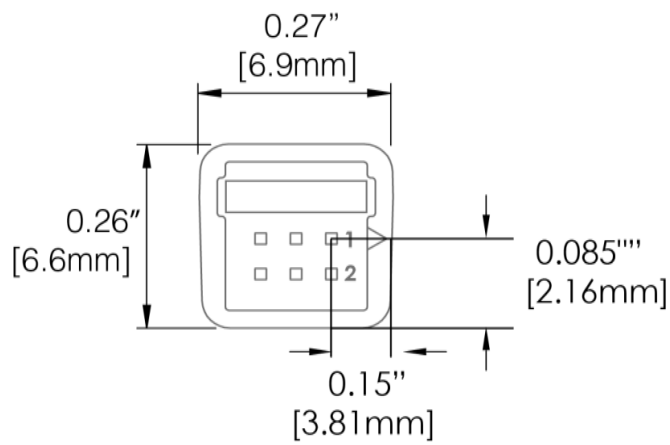

5. Before wave soldering, consult the table below for heating and cooling procedures. Do not expose product to temperatures in excess of listed maximum. Please note the table below applies to the F660/F662, F661/F663, and RFS300 models.

Table: Thermal Profile

Maximum Temperature	Peak Duration	Δ Preheat Ramp	Δ Heat Ramp	Δ Ramp Down
260 °C	10 seconds across both waves	\wedge 4 °C/sec	\wedge 200 °C/sec	\vee 5 °C/sec
500 °F	10 seconds across both waves	\wedge 7.2 °F/sec	\wedge 360 °F/sec	\vee 9 °F/sec

6. Contact technical support with any further questions at +1 (877) 334-7332.

3.3 Special Mechanical Requirements Requiring Adhesive

For systems where the sensors are mounted vertically, or where high vibration or shock-loading is expected, Degree Controls recommends addition of an electronics grade silicon RTV (room temperature vulcanizing) adhesive, installed according to IPC standards. This will form a tough, permanently flexible bond to the printed circuit board. Degree Controls recommends Loctite® SI 5011CL or equivalent. Silicone should be applied after the soldering/wave processes are complete, and used to affix the perimeter of the part, not applied underneath.

The F661/F663 sensor is soldered at one end only, and so silicon RTV is most important for this version.

4 Communication

The F660/F662, F661/F663, and RFS300, support two methods of communication: UART and I²C. For the F660/F662 and F661/F663, the mode of communication is determined by the resistance between the sensor's address line and ground. If no resistor is placed between the address and ground, the sensor will communicate using UART. I²C communication and I²C sensor address are both based on resistor value implementation.

4.1 UART Communication

The communication protocol described below is for communication between a master host and the slave F66X device. This protocol is used to read/write configuration variables and to read process variables from the sensor. The host can configure the sensor by transmitting a "Memory Write" command which contains the memory index and the new data within the command. The host reads configuration variables using the "Memory Read" command. For multi-byte configuration variables, the data format is "little endian". The lowest address is the least significant byte. Four process system variables (Velocity, Tamb, Power, and Raw Velocity) can also be read from the sensor using the "Read Velocity", "Read Tamb", "Read Power", and "Read Raw Velocity" commands.

4.1.1 Hardware

The sensor UART RX and TX signals are digital signals from the internal processor's UART. To convert to true RS232 signals, a 3.3v UART-RS232 level converter is required.

4.1.2 Configuration

UART configuration is fixed at 19200 baud rate, 8 data bits, no parity, 1 stop bit.

4.1.3 Protocol

The sensor is a slave device and supports several different commands. Both transmit and reply command message lengths are four bytes. The fourth byte is a checksum byte to verify message integrity. The checksum byte is determined by performing an “exclusive or” logic operation of the first three bytes. The tables below define the seven Host commands supported and the appropriate sensor reply.

Byte	1	2	3	4	1	2	3	4
Read Velocity	1	0	0	checksum	Velocity (Hi)	Velocity (Lo)	0	checksum
Read Tamb	2	0	0	checksum	Tamb (Hi)	Tamb (Lo)	0	checksum
Read Power	3	0	0	checksum	Power (Hi)	Power (Lo)	0	checksum
Memory Write	6	Memory Index	Data	checksum	Memory Index	Data	0	checksum
Memory Read	7	Memory Index	0	checksum	Memory Index	Data	0	checksum
Read Raw Velocity	9	0	0	checksum	Velocity Raw (Hi)	Velocity Raw (Lo)	0	checksum
RESET	12	0	0	checksum	n/a	n/a	n/a	checksum

UART Figure 1: Process System Variables

4.1.4 Password Protection

Setpoints designated as (RWP) in the Memory Map require two consecutive Memory Write commands to change the setpoint.

Command #1: Memory Write 0xAA to the Password (index 83).

Command #2: Memory Write the new value to the password protected register. If valid, sensor will accept the commands and write the new value. The Password (index 83) is automatically reset to 0xFF, the protected default state.

Caution:

- If the sensor receives a message with an invalid command byte or an invalid checksum, the message will be discarded, and the Sensor will not reply.
- If the sensor receives a partial message, the message will be discarded, and the Sensor will not reply.
- The host should use the “Read Velocity”, “Read Tamb”, “Read Power”, and “Read Raw Velocity” commands to read these double byte variables.
- When reading the double byte process variables Velocity (index 67), Raw Velocity (index 69), T Ambient Temperature (index 71), T Flow Temperature (index 73), Power Average (index 75), using the single byte “Memory Read” command, read the Low Byte first, then read the High Byte. This prevents a “byte mismatch” reading error.

4.1.5 Alarm Configuration

Note: If you are planning to utilize your F660/F662, F661/F663, or RFS300 as a control or alarm solution, please contact our technical support team at +1 (877) 334-7332 so that we can properly advise you based on your specific project parameters.

4.2 I²C Communication

By default, the F660/F662 and F661/F663 are configured to run in UART communication mode. In order to switch to I²C mode, a resistor must be used to set the I²C address, by placing it between the Alarm/Address pin and ground. The value of the resistor determines the I²C address. The resistor values table below designates which pin to connect to ground via the resistor for both the F660/F662 and F661/F663. Up to 32 I²C addresses may be set in this fashion.

4.2.1 I²C Communication Protocols

The communication protocol described below is for communication between the I²C master host and the I²C slave F66X. This protocol is used to read/write configuration variables and to read process variables from the sensor. Reading and writing to the sensor uses the same protocol that is commonly used to read and write to EEPROM's. For multi-byte configuration and process variables, the data format is "little-endian", the low order byte of the number is stored in memory at the lower address.

The protocol sequence is as follows:

- Each of the sensors is assigned a unique 7-bit address based on the resistance between the address line and ground (See tables below).
- The I²C commands for the sensors are defined as per the following tables.

1	7	1	1	8	1	8	1	1
S	Slave Address	Wr	A	Sub Address	A	Data Byte	A	P
S	=			=			Start bit	
Slave Address			=			Sensor Address		
Wr			=			0		
A			=			Acknowledge from the Sensor		
Sub Address			=			Index into the Sensor's Memory Map		
Data Byte			=			Data written to the sensor at the Sub Address		
P			=			Stop bit		

I²C Figure 1: Write Byte

1	7	1	1	8	1	1	8	1	1	8	1	1
S	Slave Address	Wr	A	Sub Address	A	S	Slave Address	Rd	A	Data Byte	A	P
S	=			=			=			Start bit		
Slave Address			=			=			Sensor Address			
Wr			=			=			0			
Rd			=			=			1			
A shaded			=			=			Acknowledge from the sensor (0 to indicate Ack)			
Sub Address			=			=			Index into the sensor Memory Map			
Data Byte			=			=			Data from the sensor at the Sub Address			
A non-shaded			=			=			Acknowledge from the Host (1 to indicate end of read cycle)			
P			=			=			Stop bit			

I²C Figure 2: Write Byte

1	7	1	1	8	1	1	8	1	1	8	1	8	1	1
S	Slave Address	Wr	A	Sub Address	A	S	Slave Address	Rd	A	Data Lo Byte	A1	Data Hi Byte	A2	P
S	=			Start bit										
Slave Address	=			Sensor Address										
Wr	=			0										
Rd	=			1										
A shaded	=			Acknowledge from the Sensor (0 to indicate Ack)										
Sub Address	=			Index into the Sensor Memory Map										
Data Byte Lo	=			Data from the sensor at the Sub Address										
A1 non-shaded	=			Acknowledge from the Host (0 to indicate read cycle continues if reading a second byte, 1 to indicate end of read cycle)										
Data Byte Hi	=			Data at the next memory address (Only used if A1 was 0)										
A2 non-shaded	=			Acknowledge from the Host (1 to indicate end of read cycle)										
P	=			Stop bit										

I²C Figure 3: Read Byte(s)**Caution:**

If there is a communication failure in the midst of a read/write sequence, it is NECESSARY to issue a “Stop” bit before resuming communication with a new “Start” bit.

4.2.2 I²C Command Restrictions

1. The write cycle only supports a single byte write cycle. Multiple byte write cycles are not supported.
2. The read cycle supports a single and a double byte read cycle. Read cycles (greater than two) are not supported.

4.2.3 I²C Address

The I²C address value is calculated in accordance with the following formula: I²C Address = 192 + (Sensor # * 2). Details on the resistor value to assign to each sensor are detailed below:

Note: 1% tolerance resistors should be used.

Sensor #	Resistor Value (Ohm)	Sensor #	Resistor Value (Ohm)
0	0	16	10000
1	511	17	11500
2	820	18	12700
3	1200	19	14300
4	1500	20	16200
5	2000	21	18700
6	2490	22	21500
7	3000	23	24900
8	3480	24	28700
9	4120	25	34000
10	4700	26	41200
11	5490	27	51100
12	6040	28	64900
13	6980	29	84500
14	7870	30	121000
15	8870	31	210000

I²C Table: Resistor Values

4.2.4 Password Protection

Setpoints designated as (RWP) in the Memory Map require two consecutive I²C write commands to change the setpoint. Command #1: Write 0xAA to the Password (index 83).

Command #2: Write the new value to the password protected register. If valid, the F660/F662, /F661/F663, or RFS300 will accept the commands and write the new value. The Password (index 83) is automatically reset to 0xFF, the protected default state.

4.2.5 Alarm Configuration

If you are planning to utilize your F660/F662, F661/F663, or RFS300 as a control or alarm solution, please contact our technical support team at +1 (877) 334-7332 so that we can properly advise you based on your specific project parameters.

5 Sensor Registers

5.1 F660/F662 and F661/F663

The sensor setpoints and process parameters can be accessed by reading and writing into the memory map using the appropriate serial communications interface. The table below provides specific details for these parameters.

Index		Type	Size	Name/Description	Default
Dec	Hex				
0	0x00	RWP	1	N/A	N/A
1	0x01	RO	1	N/A	N/A
2	0x02	RW	1	N/A	N/A
3	0x03	RW	2	N/A	N/A
5	0x05	RW	2	N/A	N/A
7	0x07	RW	1	N/A	N/A
8	0x08	RW	1	N/A	N/A
9	0x09	RW	1	N/A	N/A
10	0x0A	RW	1	N/A	N/A
11	0x0B	RO	1	Calibrated (0=UNCALIBRATED, 1=CALIBRATED)	1
12	0x0C	RO	4	Unique ID:	ID Data
16	0x10	RO	4	Model Type:	ID Data
20	0x14	RO	4	Year Week:	ID Data
24	0x18	RO	6	Work Order:	ID Data
30	0x1E	RO	4	Serial Number:	ID Data
34	0x22	RO	4	N/A	N/A
38	0x26	RO	4	N/A	N/A

42	0x2A	RO	4	N/A	N/A
46	0x2E	RO	1	Tamb Velocity Low Offset: Used to calculate Tamb, (sbbb.bbbb)	CAL Data
47	0x2F	RO	1	Tamb Velocity High Offset: Used to calculate Tamb, (sbbb.bbbb)	CAL Data
48	0x30	RO	2	Calibration Method: 0=Table, nonzero=Quadratic Equation (zero flow tau)	CAL Data
50	0x32	RO	2	Velocity Low Range: From Model P/N, (mm/sec)	CAL Data
52	0x34	RO	2	Velocity High Range: From Model P/N, also used to determine V output, (mm/sec)	CAL Data
54	0x36	RO	1	K Factor: For Velocity Temperature Compensation	CAL Data
55	0x37	RO	1	PGAIN: Proportional Band (°C)	CAL Data
56	0x38	RO	1	IGAIN: Integral Gain (Repeats per Minute)	CAL Data
57	0x39	RO	1	Calibration Temperature: For Velocity Temperature Compensation (°C)	CAL Data
58	0x40	RO	1	Offset Temperature: ΔT from Tamb to Tflow, (°C)	CAL Data
59	0x3B	RW	2	N/A	N/A
61	0x3D	RW	2	N/A	N/A
63	0x3F	RW	1	Sample Time: Determines the sample time (sec) used to calculate the rolling average velocity. Value range is (0 to 5), results in sample times (0.4 sec to 5.0 sec). Examples: 0=.4 sec, 1=1.0 sec, 2=2.0 sec, 3=3.0 sec, 4=4.0 sec, 5=5.0 sec.	3
64	0x40	RO	2	Firmware Version:	102
66	0x42	RO	1	Status: (bit mapped) bit 0: N/A bit 1: Flow bead Control Error bit 2: N/A bit 3: Ambient Temperature Sensor Error bit 4: Air Flow Temperature Sensor Error bit 5: N/A bit 6: N/A bit 7: N/A	N/A
67	0x43	RO	2	Velocity: Velocity measured from last conversion cycle, (mm/s)	N/A
69	0x45	RO	2	Raw Velocity Reading: Unfiltered velocity measurement (mm/s)	N/A
71	0x47	RO	2	Ambient Average: Temperature measured from the last conversion cycle, (°C * 100) Example: A temperature of 31.2°C would be represented as 3120	N/A
73	0x49	RO	2	Flow Temperature: Temperature of the flow thermistor, (°C * 100)	N/A
75	0x4B	RO	2	Power Average: Calculated power to maintain Tflow setpoint, (mw * 100) Example: A power value 28.62 mw would be represented as 2862	N/A
77	0x4D	RO	2	N/A	N/A
79	0x4F	RO	2	N/A	N/A

81	0x51	RO	1	N/A	N/A
82	0x52	RO	1	N/A	N/A
83	0x53	RW	1	Password: To write to RWP type items, this Password register must first be set to 0xAA. Then a second write command can write to the RWP item. Password is automatically reset to 0xFF after any command accessing index 0 thru 82.	0xFF

Notes:

1. RW are Read/Write setpoint variables.
2. RWP are Read/Write setpoint variables that are Password protected.
3. RO are Read Only variables.
4. When sensor registers are referenced within this document, the sensor register Name and Index will be italicized with the index number displayed within parenthesis. For example, the Sample Time at index 63 would be depicted as *Sample Time (index 63)*. The index number will be in decimal format.

5.2 RFS300

The sensor setpoints and process parameters can be accessed by reading and writing into the memory map using the appropriate serial communications interface. The table below provides specific details for these parameters.

Index		Type	Size	Name/Description	Default
Dec	Hex				
0	0x00	RWP	1	N/A	N/A
1	0x01	RO	1	N/A	N/A
2	0x02	RO	1	N/A	N/A
3	0x03	RO	2	N/A	N/A
5	0x05	RO	2	N/A	N/A
7	0x07	RO	1	N/A	N/A
8	0x08	RO	1	N/A	N/A
9	0x09	RO	1	N/A	N/A
10	0x0A	RO	1	N/A	N/A
11	0xAA	RO	1	Calibrated (0=UNCALIBRATED, 1=CALIBRATED)	1
12	0x0C	RO	4	Unique ID:	ID Data
16	0x10	RO	4	Model Type:	ID Data
20	0x14	RO	4	Year Week:	ID Data
24	0x18	RO	6	Work Order:	ID Data
30	0x1E	RO	4	Serial Number:	ID Data
34	0x22	RO	4	N/A	N/A

38	0x26	RO	4	N/A	N/A
42	0x2A	RO	4	N/A	N/A
46	0x2E	RO	1	Tamb Velocity Low Offset: Used to calculate Tamb, (sbbb.bbbb)	CAL Data
47	0x2F	RO	1	Tamb Velocity High Offset: Used to calculate Tamb, (sbbb.bbbb)	CAL Data
48	0x30	RO	2	N/A	N/A
50	0x32	RO	2	Velocity Low Range: From Model P/N, (mm/sec)	CAL Data
52	0x34	RO	2	Velocity High Range: From Model P/N, also used to determine V output, (mm/sec)	CAL Data
54	0x36	RO	1	K Factor: For Velocity Temperature Compensation	CAL Data
55	0x37	RO	1	PGAIN: Proportional Band (°C)	CAL Data
56	0x38	RO	1	IGAIN: Integral Gain (Repeats per Minute)	CAL Data
57	0x39	RO	1	Calibration Temperature: For Velocity Temperature Compensation (°C)	CAL Data
58	0x40	RO	1	Offset Temperature: ΔT from Tamb to Tflow, (°C)	CAL Data
59	0x3B	RO	2	Dead Air Default Constant: Used to Calculate Air Velocity when a Dead Air Cal has been performed.	N/A
61	0x3D	RO	2	Dead Air Power: Used to Calculate Air Velocity after Dead Air Cal has been performed.	N/A
63	0x3F	RW	1	Sample Time: Determines the sample time (sec) used to calculate the rolling average velocity. Value range is (0 to 5), results in sample times (0.4 sec to 5.0 sec). Examples: 0=.4 sec, 1=1.0 sec, 2=2.0 sec, 3=3.0 sec, 4=4.0 sec, 5=5.0 sec.	3
64	0x40	RO	2	Firmware Version:	102
66	0x42	RO	1	Status: (bit mapped) bit 0: N/A bit 1: Flow bead Control Error bit 2: N/A bit 3: Ambient Temperature Sensor Error bit 4: Air Flow Temperature Sensor Error bit 5: N/A bit 6: N/A bit 7: N/A	N/A
67	0x43	RO	2	Velocity: Velocity measured from last conversion cycle, (mm/s)	N/A
69	0x45	RO	2	Raw Velocity Reading: Unfiltered velocity measurement (mm/s)	N/A
71	0x47	RO	2	Ambient Average: Temperature measured from the last conversion cycle, (°C * 100) Example: A temperature of 31.2°C would be represented as 3120	N/A
73	0x49	RO	2	Flow Temperature: Temperature of the flow thermistor, (°C * 100)	N/A
75	0x4B	RO	2	Power Average: Calculated power to maintain Tflow setpoint, (mw * 100) Example: A power value 28.62 mw would be represented as 2862	N/A

77	0x4D	RO	2	N/A	N/A
79	0x4F	RO	2	N/A	N/A
81	0x51	RO	1	N/A	N/A
82	0x52	RO	1	N/A	N/A
83	0x53	RW	1	Password: To write to RWP type items, this Password register must first be set to 0xAA. Then a second write command can write to the RWP item. Password is automatically reset to 0xFF after any command accessing index 0 thru 82.	0xFF

Notes:

1. RW are Read/Write setpoint variables.
2. RWP are Read/Write setpoint variables that are Password protected.
3. RO are Read Only variables.
4. When sensor registers are referenced within this document, the sensor register Name and Index will be italicized with the index number displayed within parenthesis. For example, the Sample Time at index 63 would be depicted as Sample Time (index 63). The index number will be in decimal format.

6 Degree Controls Inc. Product Warranty

For a period of one (1) year following the date of delivery, and subject to the other provisions of this Warranty Section, DegreeC warrants that all new products that are both (a) manufactured by DegreeC and (b) purchased directly from DegreeC (or an authorized distributor of DegreeC) shall be free of material defects in materials and workmanship. Buyer's sole and exclusive remedy, and DegreeC's sole and exclusive obligation, in the event of any product defect shall be for DegreeC to, at its option, repair or replace such products free of charge. In no event shall DegreeC be liable for ordinary wear and tear. In order to get the benefit of the foregoing warranty, Buyer must examine the delivered products immediately upon receipt thereof and report to DegreeC, in writing, any visible defects within ten (10) working days of such receipt. Buyer's failure to report defects within the foregoing time period will be deemed an unqualified waiver of any and all of Buyer's rights to warranty claims. DegreeC does not provide any warranty for third party parts, components, or products that are not manufactured by DegreeC. Such parts, components, or products may be warranted by third parties on a "pass through" basis. The foregoing remedies shall not apply to any product failure caused in whole or in part by (i) Buyer's failure to operate, maintain, or service the products in accordance with DegreeC's documentation, (ii) any alteration, modification, or repair made to the products other than by DegreeC, or (iii) use of the products for a purpose other than that for which it is intended. THE FOREGOING EXPRESS WARRANTY extends only to the original customer of DegreeC or DegreeC's authorized distributor, as the case may be. THE CORRECTION OF ANY DEFECT IN, OR FAILURE OF, PRODUCTS BY REPAIR OR REPLACEMENT IN ACCORDANCE WITH DEGREEC'S POLICIES DESCRIBED HEREIN SHALL BE DEGREEC'S SOLE AND EXCLUSIVE OBLIGATION AND THE SOLE AND EXCLUSIVE REMEDY OF BUYER FOR ANY AND ALL LOSSES, DELAYS OR DAMAGES RESULTING FROM THE PURCHASE OR USE OF DEGREEC'S PRODUCTS. OTHER THAN THE LIMITED WARRANTY SPECIFICALLY STATED HEREIN, DEGREEC SPECIFICALLY DISCLAIMS ANY AND ALL OTHER WARRANTIES WITH RESPECT TO DEGREEC'S PRODUCTS, INCLUDING THE PERFORMANCE THEREOF AND ANY SERVICES PROVIDED TO BUYER, EITHER EXPRESS OR IMPLIED, INCLUDING, WITHOUT LIMITATION, ANY WARRANTY ARISING FROM A COURSE OF DEALING OR USAGE OF TRADE, NON-INFRINGEMENT AND ANY IMPLIED WARRANTIES OF MERCHANTABILITY AND FITNESS FOR A PARTICULAR PURPOSE OR USE.