

ROOSTER™ MONITOR100

Airflow Alarm Version 1.03

User Manual

**High Performance Airflow Monitor
with Full-Color Touch Screen Display**

Complete Kit includes:

- Alarm Module
- Choice of Sensor Type
- Power Supply



Contents

Product Overview	3
Hard Button Overview	3
Feature Overview	4
Rear Panel Layout for Advanced Connections	6
Technical Specifications	6
Installation	7
Mounting the Rooster™ Monitor100	7
Wiring the Rooster™ Monitor100	8
Probe Sensor	8
Sidewall Sensor	8
Single Walled Cabinet	9
Dual Walled Cabinet	9
In-line Sensor	10
Sensor Installation Procedure – Single Wall	11
Sensor Installation Procedure – Dual Wall	11
Sash Position Switch	12
Night Setback Input	12
Boot Up Procedure	13
Access Tier Privileges: USER, EH&S & CERTIFIER	13
Set/Change Passwords	13
Calibration Procedure	14
Calibration Troubleshooting	15
Alarm Threshold Configuration	16
Alarm Troubleshooting	16
Alarm Controls	17
Night SetBack	17
Alarm Ringback	17
Backlight Dimming	18
Latch Alarm	18
Alarm Delay	18
Startup Delay	19
Airflow Resolution	19
Airflow Sensitivity	19
I/O Polarity	19
USB Field Upgrade Procedure	20
Factory Reset Procedure	20
GUI Map	21
Warranty	21

Product Overview

Congratulations on your purchase of the Rooster™ Monitor100. The Rooster™ Monitor100 is a next-generation airflow monitoring and alarm system for use in a variety of critical containment applications, where airflow is required to be viewed, monitored, alarmed, and communicated to building and laboratory systems.

A brief overview of the Rooster™ Monitor100's many features, including but not limited to:

- Glove-friendly touchscreen
- Best in class air velocity sensing
- Sensor for canopies, negative pressure cabinets, as well as for use in hospital/lab/kitchen.
- Quick, 2 step calibration process
- Bright backlit display
- Password protected access tiers limit access to critical functions for authorized users.

The Rooster™ Monitor100 is the first airflow alarm monitor which allows USB-based plug and play firmware upgrades, to keep your product current and operating to the latest standards. Register with us to receive these product updates at <http://www.degrec.com/en/support/register.html>

This manual will guide you through installation, calibration procedures, firmware upgrades, alarm control settings, and the full range of features for the Rooster™ Monitor100.

Hard Button Overview

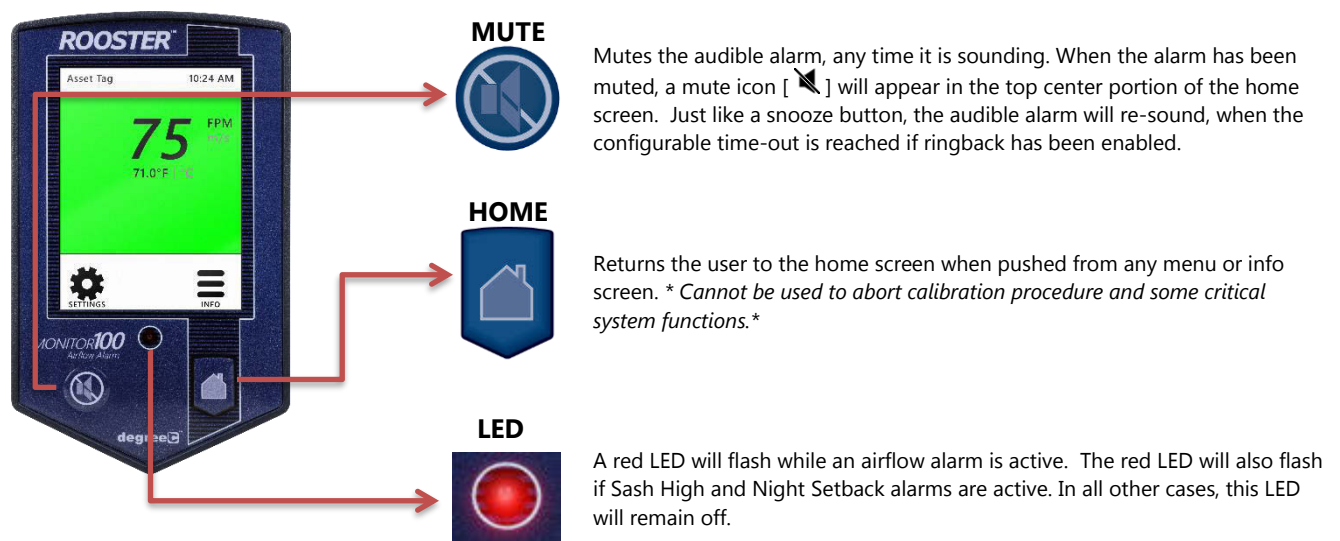

Soft Buttons and Home Screen Layout

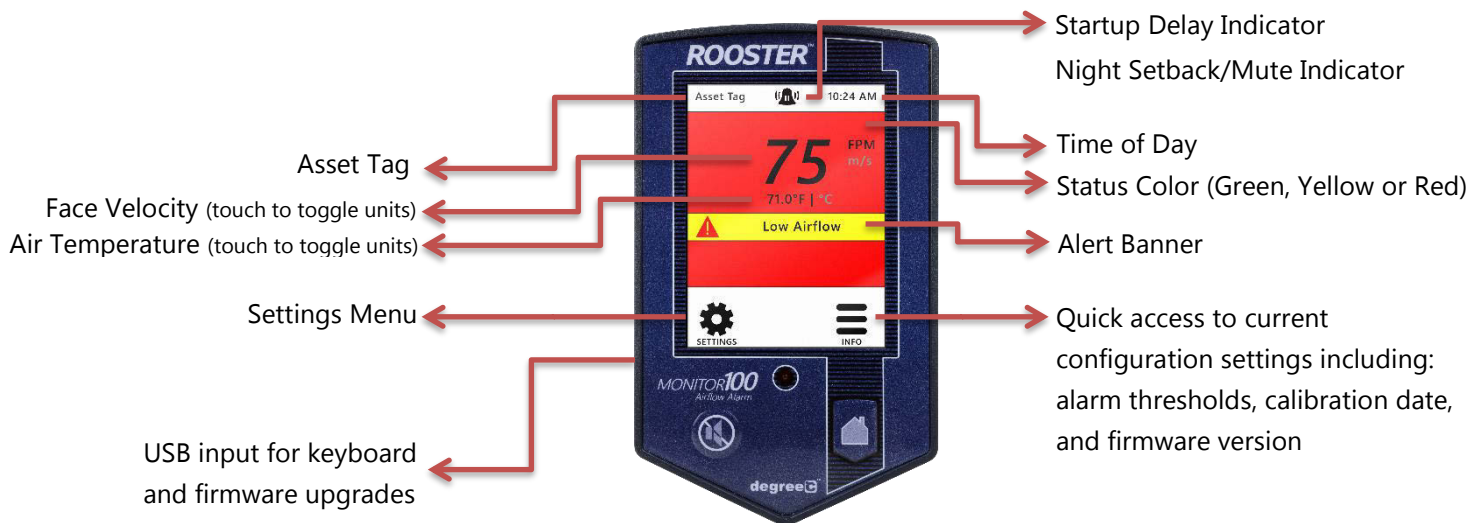

FEATURE OVERVIEW

Custom Asset Tag

Users logged in as EH&S can change default "Asset Tag" to a custom tag. This is useful for naming the chemical fume hood, or company asset, or laboratory. A 12-digit numeric asset tag can be set with the provided on-screen keypad OR plug in a USB interface keyboard to enter a 12-character alphanumeric tag.

Home > Settings > System > Advanced > Configure Asset Tag

Clock

Users logged in as EH&S or Certifier can set time, date and change clock to display in 12 or 24-hour format.

Home > Settings > System > Time > Date and Time Settings

Keypad and Button Sounds

Users may toggle keypad and button beep sounds on and off.

Home > Settings > System > Alarms/Sound > Key Beep

Device Volume

Users can toggle through low, medium or high alarm volumes. If logged in as an EH&S or Certifier, a global minimum volume threshold can be set. This restricts a standard User from setting an alarm volume too low for particular facility safety requirements.

Home > Settings > System > Alarms/Sound > Device Volume

On-Screen Alert Banners

A yellow banner will appear beneath on-screen velocity readings to alert users regarding various scenarios:
>Home

Toggle Velocity Unit Type

Instantly toggle displayed velocity units from m/s to fpm or vice versa by pressing on the displayed velocity reading on the home screen.

>Home

Toggle Temperature Type

Instantly toggle displayed temperature units from Fahrenheit to Celsius or vice versa by pressing on the displayed temperature reading on the home screen.

>**Home**

Password-Protected Access Tiers: Certifier & EH&S

Password protected access tiers enable advanced configuration options and features.

Home> Settings>System>Advanced>Change Passwords

USB Interface for Field Upgrade Procedure

Firmware upgrades can be installed on-site via USB flash drive. *See page 21 of this manual for more information on performing a Field Upgrade.*

Customizable Boot Screen

Our engineers can configure your unit with a custom image or logo file (240x320) in portable network graphic (.png) format to display on bootup. Contact our sales team to get started: sales@degrec.com

Night Setback

EH&S or Certifier users can configure 3 convenient modes (Audible, Muted, or Off) of operation. The Rooster™ Monitor100 is a normally open device. To trigger audible or muted night setback, the dry contact relay must be closed. See Calibration Procedure for instructions on how to setup night setback alarm thresholds.

Home> Settings>System>Alarms/Sound>Alarm Controls>Night Setback

Alarm Latching

EH&S or Certifier users can setup latched alarms to indicate that a low airflow state has occurred in the "Alarm Controls" menu. User must then enter EH&S or Certifier passcode to unlatch an alarm.

Home> Settings>System>Alarms/Sound>Alarm Controls>Latch Alarm

Alarm Ringback

EH&S or Certifier users can configure the amount of snooze time before an alarm rings again after being muted in the "Alarm Controls" menu. Optionally, the audible alarm can be turned off completely.

Home>Settings>System>Alarms/Sound>Alarm Controls>Ringback

Backlight Dimming

Users can toggle the brightness setting, as well as the brightness of the screen when set to "dim". A "time before dim" option is available that sets the screen to dim after a predetermined amount of time has expired.

Home> Settings>System>Brightness

Airflow Resolution

EH&S or Certifier users can select the units of measurement displayed for the resolution of air velocity in either meters per second or feet per minute.

Home>Settings>System>Advanced>Airflow Resolution

Two Point Calibration

For greater accuracy and performance, the Rooster™ Monitor100 uses a two-point calibration procedure to collect both a high velocity and low velocity reference point. The low velocity reference point is collected by leaving the sensor cover in place while performing this calibration step (**note:** for probe sensor calibration only). See Calibration Procedure on page 15 of this manual.

Home>Settings>Calibration>Calibrate

Rear Panel Layout for Advanced Connections

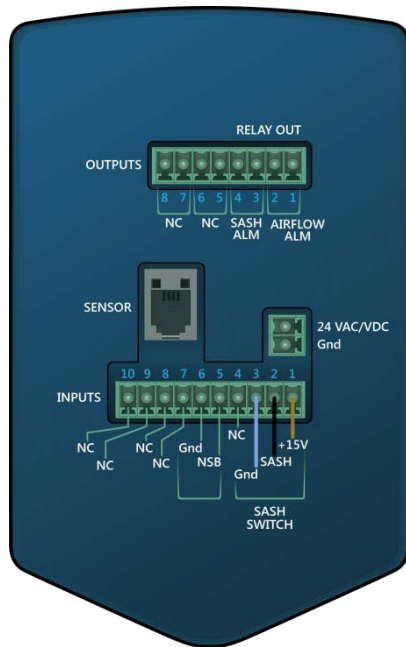

Rear Panel View of Rooster™ Monitor100

Connection Description	Connector Type	Mating Connector
Power Entry	2-Pin, polarized, Phoenix Contact	Included and attached to AC/DC power supply
Sensor Connection	RJ-11	Included as part of sensor assembly
Output Connection	8-pin, polarized, Phoenix Contact *2-position connectors will fit	Not included. 8-position orderable Part Number: Phoenix Contact 1803633 2-position orderable Part Number: Phoenix Contact 1803578
Input and Sash Connections	10-pin, polarized, Phoenix Contact *2-position connectors will fit	Not included. 10-position orderable Part Number: Phoenix Contact 1803659 2-position orderable Part Number: Phoenix Contact 1803578

Degree Controls recommends 18-24 AWG wires be used with screw terminal connections.

Optional Sash Switch kit, Degree Controls P/N: 62310AS004 includes 10-position Phoenix Contact connector.

Technical Specifications

Alarm Module Size	3.2" x 5.25" x 0.75" (78mm x 134mm x 19mm)
LCD Display Area	2.25"x 2.73" (57mm x 70mm)
Airflow Velocity Range	30-2,000 fpm (0.15- 10.0 m/s)
Response Time	< 1 second
Supply Voltage	24VAC/VDC
Night-Set Back	Dry Contact Closure (0V)
Sash Switch	Pin 1= +15V Power (For Proximity SW) Pin 2= SASH SW (Contact or Proximity) Pin 3= GND (Contact or Proximity)
Relay Outputs	Qty. (2), 1A, 24VDC [Pins 1-2 Air Alm, Pins 3-4 Sash Alm]
Power Adapter	90-250V
Red LED indicator	160° viewing angle
Alarm Volume	0 - 85dB (adjustable)
Relative Humidity	(non-condensing) 5 - 95%
Operating temperature	40°F - 140°F (5°C - 60°C)
Storage temperature	-40°F - 185°F (-40°C - 85°C)
Weight	<6oz (<170g)
Compliance Standards	CE, RoHS

Installation

Mounting the Rooster™ Monitor100

After configuring your wires, the Rooster™ Monitor100 is mountable to a cabinet or physical wall panel by first securing the back plate, and, once this is complete, the Rooster™ will snap right onto the backplate. Two backplate versions are available:

- 1) **Wall mount:** This backplate sits directly on the wall or cabinet surface, and secured by self-tapping screws, or industrial Velcro.
- 2) **Semi-Flush:** This back plate sits partially inside a standard electrical gang box, allowing the Rooster™ to be recessed and sit approximately 0.6" [15mm] proud of the mounting surface.

Wall-mount backplate:

For installations where the Rooster™ Monitor100 is mounted directly to a flat surface, the Wall-mount backplate is used. The installation consists of a hole for the sensor and power wires to access the unit, and 2 pre-drill holes for self-tapping fasteners included in your kit.

Alternatively, the base may be mounted with industrial Velcro fasteners.

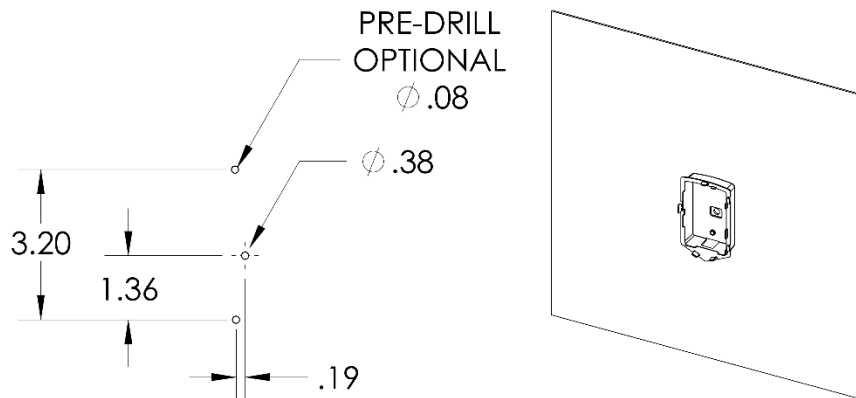

Semi-flush backplate:

For installations where the Rooster™ Monitor100 should be semi-flush, and the user is capable of cutting a rectangular hole, as shown below, the Rooster™ Monitor100 may be mounted in semi-flush manner, where the backplate is recessed into a standard electrical gang box. In this method, the Rooster™ Monitor100 only protrudes 0.6" (15mm) from the wall panel.

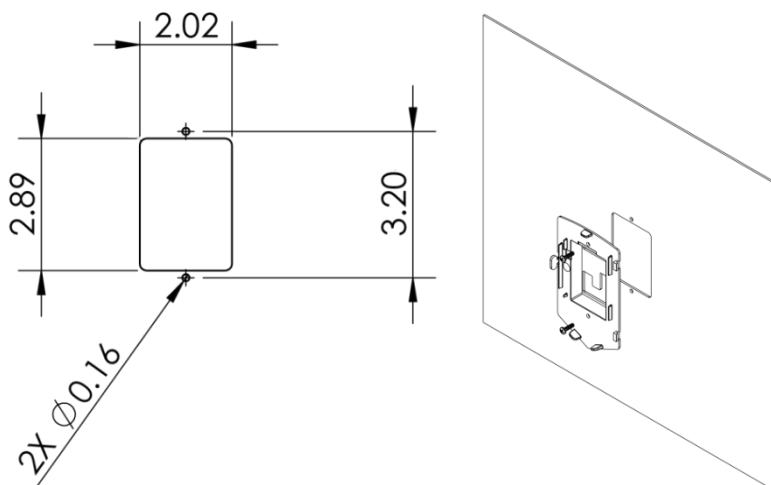

Wiring the Rooster™ Monitor100

Using the backplate label as a reference, the next step is to prepare the wiring harness for the Rooster™ Monitor100. Once the wire harnesses are pulled through the opening and attached to the Rooster™, then the front touch panel assembly can be snapped into place.

Degree Controls recommends 18-24 AWG for all wiring connections to the input and output connectors. Both the Sensor and power supply connections have been prepared for you, and merely need to be pulled through the sheetmetal cutout and connected to the Rooster™ as pictured on **page 7** of this manual. If the Sash Switch option is purchased, this is pre-connectorized for you as well.

The Rooster™ Monitor100 has additional input and output capabilities for night setback and customers using their own sash switch. The cable harnesses should be prepared by the client, using the orderable mating connectors listed above.

The IO connectors present on the Rooster™ Monitor100 have some pins deactivated as these are reserved for future Rooster™ models designed for more advanced control functionality:

- Output Connectors, Pins 5-8
- Input Connectors, Pins 7-10

These pins should be left non-connected.

Probe Sensor

The probe sensor should be located in the duct system in the best laminar (stable) flow possible. Good sensor placement practices should be followed. Sensor should be placed at least two duct diameters away from duct elbows and constrictions.

Single-side Probe Gland Fitting (part# HA1203)

Drill 5/8" 0.625 (16mm) hole.
Adjust insertion depth and tighten (A) gland nut onto sensor probe.

Insert into duct hole, with wider flange first, then rotate into position.

Tighten mounting nut (B) in left-hand direction.

Make sure the sensor head faces airflow by positioning the probe elbow in the flow direction (C).

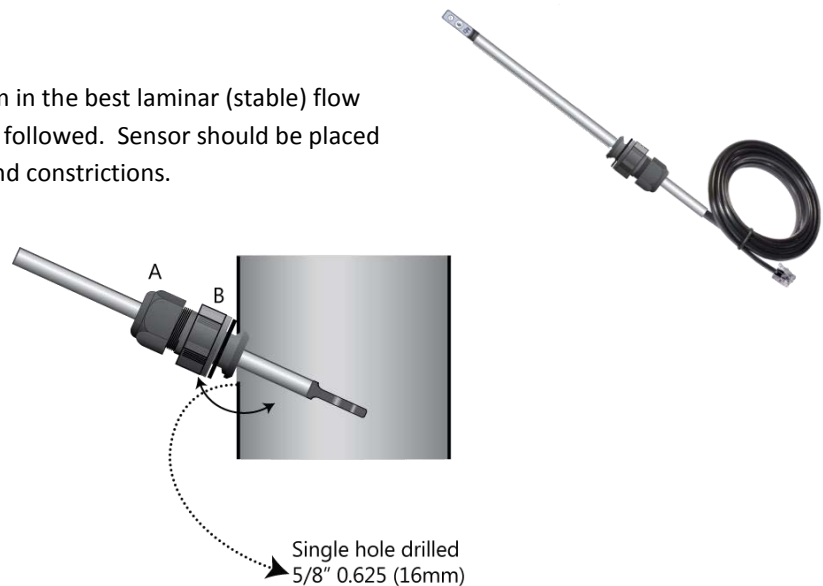

Sidewall Sensor

When determining the face velocity of a negatively pressurized cabinet, the Sidewall sensor is often the best choice, as it measures clean, temperature-controlled, laboratory air.

This is preferable to measuring potentially heated, dirty air in the exhaust duct.

The Sidewall sensor has a removable air screen, which is washable and provides a level of sensor protection from tampering.



Single Walled Cabinet

When an airflow channel only needs to pass through a single sheet metal panel, the “single wall” installation method is required. This is most typical when the Sidewall sensor is placed on the side of a cabinet, and airflow simply travels through the sensor body with no need for additional ducting. In this case, the user will not need to use the PVC flex tubing, nor the end cap, which is included in Rooster™ Monitor100 assembly.

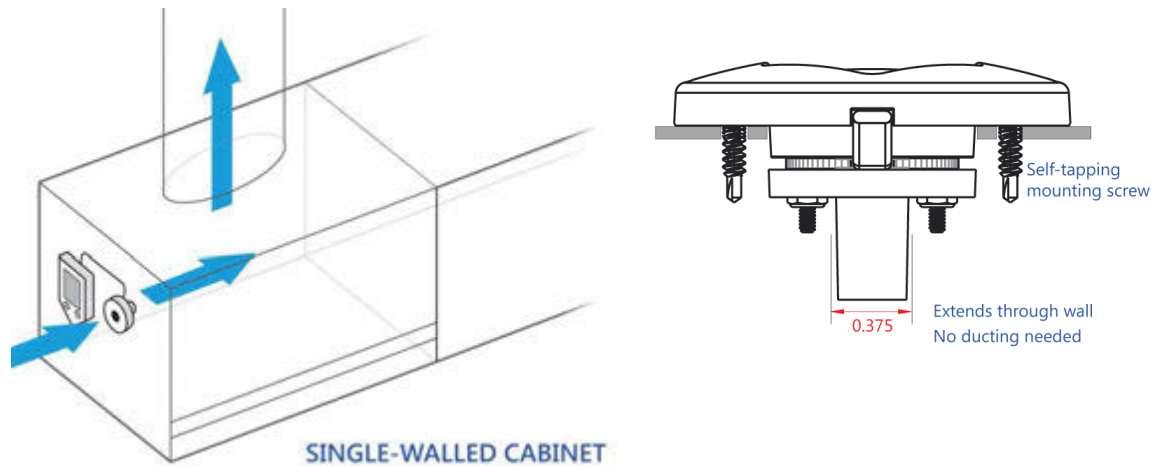

Dual Walled Cabinet

For those installations where the Sidewall sensor will be on the front face of the fume hood, and a duct is needed to create an airflow path from the front face to the inside face of the cabinet, this “dual walled” installation method is required. This method is also required for installations where the Sidewall sensor is mounted on the side, but there are two sheet metal walls for the air flow to travel through. In both of these scenarios, the Sidewall sensor will need to be installed according to the “dual walled” method depicted in the diagram below. The dual walled solution simply involves the use of the supplied PVC tubing and end cap.

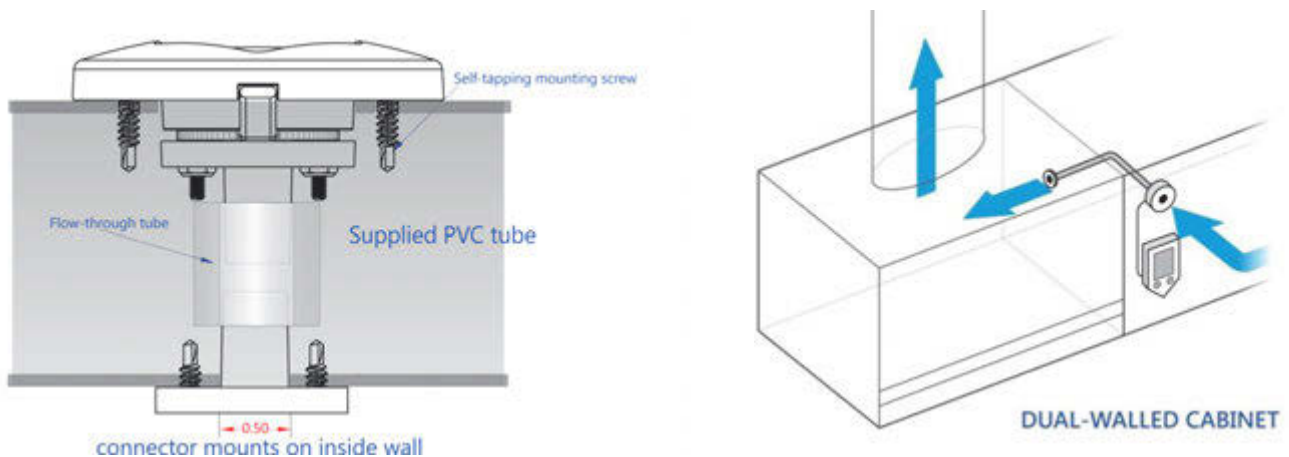

In-line Sensor

We recognize that certain airflow monitors, already installed in cabinets, may have failed in the field or do not meet the level of safety required in recent years. For this reason, the Rooster™ can be ordered with an in-line sensor which connects quickly by splicing into the existing flow tube used by other monitors. Also, in some installations, the equipment manager may require a sensor installation where tampering is prevented, by moving the sensor assembly out of sight, and away from any tool access. For these scenarios, Degree Controls has developed the Inline Sensor. Suggested installation procedure is depicted below. **Inline sensor includes sensor and tubing only. Call us for pricing on additional installation components.*

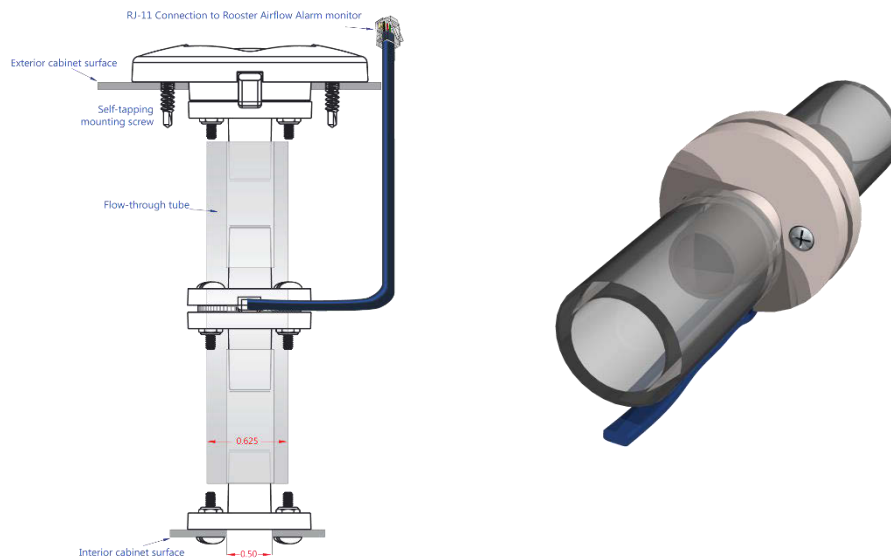

Sensor Installation Procedure – Single Wall

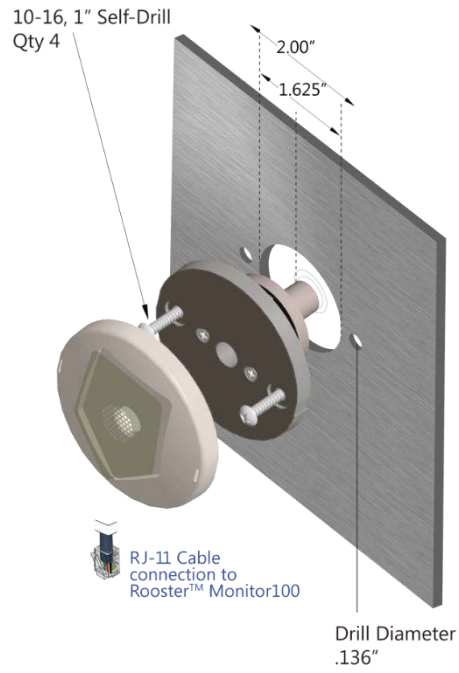

Sensor Installation Procedure – Dual Wall

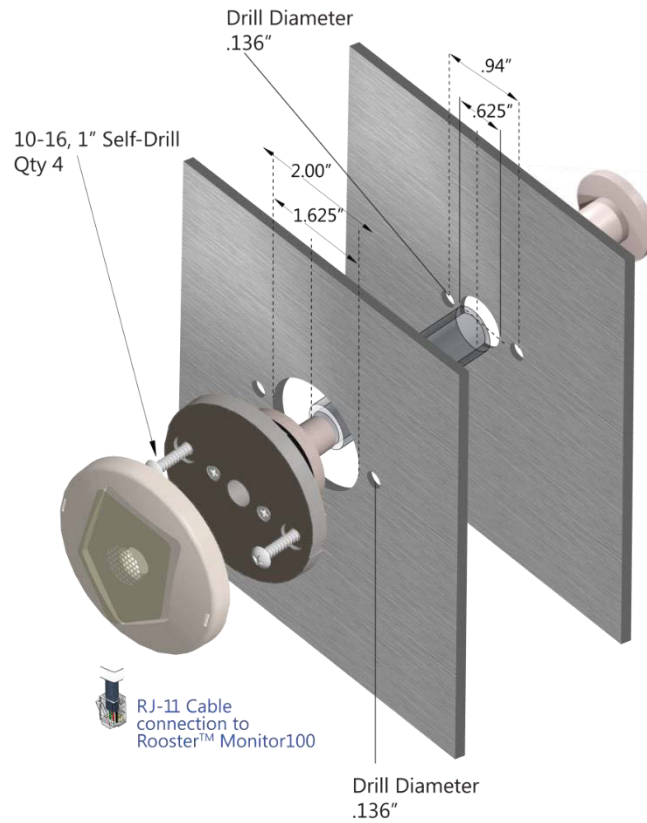

Sash Position Sensor

DegreeC can provide you with an optional Sash Sensor. This inductive proximity sensor, switches state when it comes into contact with metal surfaces. This sash sensor is a normally open device, meaning it closes upon sensing metallic objects.

*The design intent is as follows: When the sash is in a safe position, the proximity sensor should not detect metallic object/strip, however, using the I/O polarity menu (**Home>Settings>System>Advanced>I/O Polarity**) on the Rooster™ Monitor100, this logic may be reversed, and any proximity sensor may be implemented.*

The DegreeC Sash Position Sensor (Part# 62310AS004), comes with three stripped and tinned wire leads; brown = +15V, black = sash, and blue = ground. Wire these in their respective positions 1, 2, and 3 on the connection block.

Note: For implementation support, or for users preferring to use a micro-switch for sash alarm activation, please contact DegreeC.

Night Setback Input

The Rooster™ Monitor100 allows the user to connect to the digital input (dry contact), on Input Connector, positions 5 & 6. The purpose of the Night Setback input is to allow the user the ability to send a remote signal to all Rooster™ Monitor100's simultaneously, which changes their behavior during low flow conditions. This signal is normally initiated by a Laboratory or Building Management System (BMS).

Once the wiring connections are made, the User can assert and remove the Night Setback signal from the BMS. Three Monitor100 setback states can be selected.

- **Audible:** In this state, when a Night setback signal is asserted, the Monitor100 will still audibly alarm when airflow drops below the NSB trip threshold. **Note:** NSB threshold is independently set.
- **Muted:** In this state, when the Night Setback signal is asserted, the Monitor100 will alarm (screen will display a red background, and the LED will flash) when airflow drops below the NSB trip threshold, but the alarm will be muted.
- **Off (default):** In this state, when the Night Setback signal is asserted, the Monitor100 will ignore it.

Boot Up Procedure

The Rooster™ does not have a power-on switch and will become energized as soon as it is plugged in. The Rooster™ boots to the screen depicted on the right, with a slot for a custom logo. The boot screen is designed to support a custom image or logo file in portable network graphic (.png) format with (240x320) dimensions.

This feature must be requested and is not setup for manual configuration.

Once the start procedure has completed, the Home screen will appear with two system buttons and an "Uncalibrated" message will appear on the yellow status banner across the screen. Before performing a first-time calibration of your unit, you will need to setup password-protected access tiers for advanced system functions (Calibration requires a Certifier passcode). This is explained in the "Access Tier Privileges" section below.



The Rooster™ Monitor can be rebooted at any time by pushing the hard "Home" and "Mute" Buttons simultaneously until the Boot Screen reappears.

Access Tier Privileges: USER, EH&S & CERTIFIER

Users have the ability to customize their containment cabinets within a defined set of options for each authorization level. There are three levels of access to the Rooster™: User, EH&S/Facility Manager and Certifier. These are managed by logging in with a 4-digit numerical passcode. The User access level does not require a passcode.

Manufacturer default passcodes:

EH&S = **8377**

Certifier = **6425**

Access Privileges Defined

Function	Passcode Required
Adjust Alarm Volume	None
Alarm Latching Settings	EH&S, Certifier
Alarm Ringback Settings	EH&S, Certifier
Mute Live Alarm	None
Perform Calibration	Certifier
Set Asset Tag	EH&S
Set Minimum Alarm Volume Threshold	EH&S, Certifier
Set Time / Clock Format	EH&S, Certifier
Toggle between Fahrenheit or Centigrade Temperature Units on Home Screen	None
Toggle between Metric or Imperial Air Velocity Units on Home Screen	None
Toggle ON/OFF Keypad Sounds	None
Unlatch Alarm	EH&S

Set/Change Passwords

To change or set a password, follow this GUI path to trigger the password change sequence:

Home > Settings > System > Advanced > Change Passwords

You will have to enter an EH&S or Certifier passcode to get access to the "Advanced" menu. To change either the EH&S or Certifier passcode, you must first re-enter the old passcode. Please note that if you are authorized to perform both EH&S and Certifier functions, you may set an identical passcode for both access tiers to make logging in and accessing key functions easier.

Calibration Procedure

Once you have installed and booted up your Rooster™ Monitor100, you must perform a first-time calibration to set alarm threshold and establish both low velocity and normal operational velocity set points. Follow this procedure to get your unit calibrated:

- 1) Before calibrating your unit, you must first make sure that the system clock and date are accurate, because the Rooster™ saves the date and time of calibration for quick referencing. Follow the path below, and set an accurate date and time (you may also choose to set the clock in 12 or 24-hour format).

Home> Settings>System>Time>Date and Time Settings

- 2) Navigate to the Calibration screen by following this path:

Home> Settings>Calibration

- 3) Push the grey "Calibrate" button to enter the Calibration menu screen.

Home> Settings>Calibration>Calibrate

- 4) In order to proceed, you will need to enter your "Certify" password. If you have not set a custom password, the factory default is "6425"

Home> Settings>Calibration>Calibrate

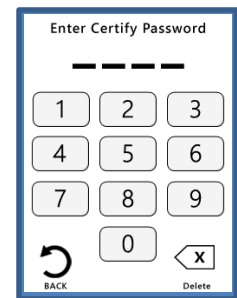

- 5) For your initial calibration, keeping the default "Normal" value for "Allowed Turbulence" is recommended. Setting the "Allowed Turbulence" to "High" will help you overcome cabinet-level airflow instability issues. In most cases, changing this setting to "High" is not needed. It should be reserved for rare circumstances where there is difficulty achieving stable, laminar airflow.

Home> Settings>Calibration>Calibrate>Allowed Turbulence

- 6) Before beginning the calibration process, select the Sensor Type that will be calibrated. The choices are Probe, Sidewall, or Inline. There are a few key differences in the setup process for both Probe and Sidewall/Inline — these steps are outlined below:

Home> Settings>Calibration>Calibrate>Sensor Type

Setup for Probe:

- a) Plug sensor into Rooster™ (ensure cap is on).
- b) Press the red "Calibrate" button and follow steps 7 through 9.

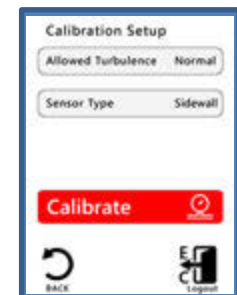
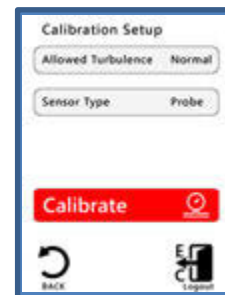

Setup for Sidewall:

- a) Plug sensor into Rooster™, and install the sensor where calibration will take place
**Note – if applicable: Sash will need to be in upright position prior to beginning calibration process*
- b) Press the red "Calibrate" button and follow steps 7 through 9.
**Note – if applicable: Once velocity is entered (and desired units are chosen (fpm or m/s), sash may be returned to normal position*

Setup for Inline:

See "Setup for Sidewall" instructions above.

- 7) Wait until the Airflow Stability indicator is constant, then select "Continue" to initiate the calibration. When the progress bar has filled up completely, you will be prompted to enter the current low airflow velocity. Press "Enter" to proceed.
- 8) When air velocity is at normal operating levels, wait until the Airflow Stability indicator is constant, then select "Continue" to initiate the calibration. When the progress bar has filled up completely, you will be prompted to enter your nominal face velocity (measured via your handheld anemometer). To toggle between m/s and fpm units, press the m/s or fpm button on the top right corner of the keypad. Press "Enter" to proceed and complete calibration.
- 9) Once valid set points have been defined, the calibration sequence will end with a "Calibration Successful!" message. If a "Calibration Failure" message is received instead, then proceed to the troubleshooting section, or repeat steps 1-9.

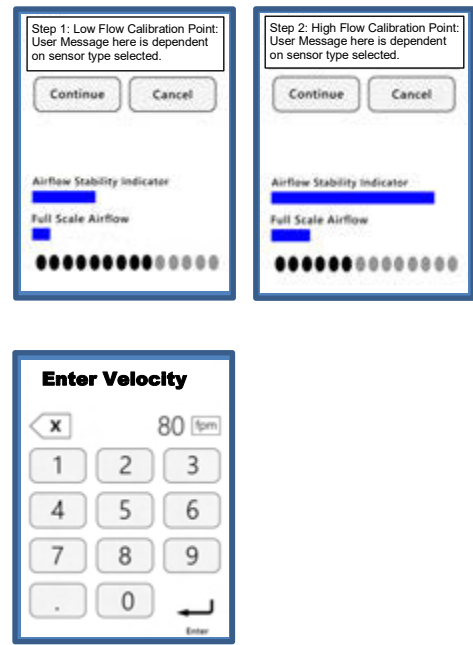

Calibration Troubleshooting

If you receive a "Calibration Failure" message, you may be experiencing one of the following common issues:

- 1) **Velocity positions are too close [Zero velocity vs. Normal velocity].** To calculate an accurate calibration curve, the Rooster™ Monitor100 requires a minimum of 20% difference between sensor readings for the low velocity and normal velocity to successfully calibrate. *There may not be enough of a difference between the sensor readings you have used during the calibration procedure.* System velocity may need to be increased to a higher than normal to ensure there is a minimum of 20% difference in velocities.
- 2) **Velocity input values are problematic.** As in #1, the Rooster™ Monitor100 requires a minimum difference of 20% between nominal values for both low and high velocity settings. First, consider the possibility of a typographical error and try to perform the sequence again. Verify that the correct values have been entered, and that there is a minimum 20% difference between them.
- 3) **Turbulence.** The Rooster™ Monitor100 has an "Allowed Turbulence" setting available to users who are having difficulty finding a sensor location with stable airflow. Although uncommon, in some systems, this can be an issue due to the mechanical or environmental design of the cabinet or laboratory. The default setting is "Normal", and should only be changed if calibration is unsuccessful, due to unstable airflow. Before changing this setting, ensure that you are following the calibration procedure properly.
Home > Settings > Calibration > Calibrate > Allowed Turbulence
- 4) **Airflow Obstruction.** Verify that your workspace is free of any obstructions in the plenum or internal blockages in the HVAC system that could lead to faulty airflow readings. You may also need to validate that your sensor is placed and installed properly. See INSTALLATION section for instructions.
- 5) **Incorrect Units:** Ensure that the correct units are selected. Units can be changed by tapping them on the home screen.

If you have tried the common fixes above, please contact our customer service team at customer.service@degrec.com or call in to our Customer Service line toll-free at (877) 334-7332.

Alarm Threshold Configuration

- To set your alarm threshold, follow the menu path below:
Home> Settings>Thresholds>Adjust Thresholds
- To set alarm thresholds, first define an alarm trip point and an alarm clear point. The **alarm trip point** is the air velocity value that will trigger an alarm. The **alarm clear point** is the air velocity value that will clear an alarm. Once you have defined these values, the alarm will trip and clear based on your settings. You may return to this menu at any time to adjust these values as needed.
- By default, no value is set to NSB (Night Setback) mode of operation. Depending on your application or setup, an active alarm during Night Setback may not be required. A specific alarm trip and clear point for Night Setback mode may be chosen. First define an alarm trip point and an alarm clear point. The **alarm trip point** is the air velocity value that will trigger an alarm. The **alarm clear point** is the air velocity value that will clear an alarm state. Once thresholds are assigned for Night Setback, the alarm may be set as "Audible" or "Muted" in the alarm controls menu on **page 17** of this manual.
Home> Settings>System>Alarms/Sound>Alarm Controls>Night Setback
- To quickly glance at threshold settings, follow this menu path below:
Home> Settings> Thresholds>Threshold Info

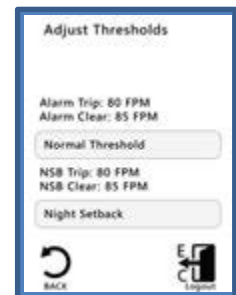

Alarm Troubleshooting

If an alarm is failing to sound or clear as intended, first verify that the alarm threshold values are valid. For both normal and NSB modes of operation, the "Alarm Trip" or "NSB Trip" point must be a lower value than the "Alarm Clear" or "NSB Clear" point to properly trigger and clear an alarm.

The Rooster™ Monitor100 offers an array of customization options for alarm behaviors. The following section provides a detailed overview on how to customize alarm behavior to meet individual needs and preferences.

Alarm Controls

To provide our users with full customization of the alarm behaviors that are best suited for their facilities and unique conditions, the Rooster™ Monitor100 allows authorized users (Certifier & EH&S) to set latching, ringback, night setback, alarm delay and airflow resolution preferences.

Night SetBack

The Rooster™ Monitor100 supports Night Setback for energy savings and greater HVAC system integration in building automation systems. Users can toggle between 3 modes of operation detailed below:

This crescent moon icon [] will appear on the top portion of the home screen when Night Setback is active

Home > Settings > System > Alarms/Sound > Alarm Controls > Night Setback

Night SetBack Modes	Definition
Audible	Enters Night Setback mode whenever relay is closed and audibly triggers an alarm when airflow drops below NSB trip point. To adjust Night Setback alarm thresholds, navigate to: Home > Settings > Thresholds > Adjust Thresholds .
Muted	Enters Night Setback mode whenever relay is closed and triggers a muted alarm when airflow drops below NSB trip point. (LED will still flash during an alarm event). To adjust Night Setback alarm thresholds, you must go to the Calibration menu and select "Adjust Thresholds". This is the default setting.
Off	Disables Night Setback mode. Device does not enter Night Setback mode when relay is closed.

Alarm Ringback

When an active alarm state is muted, ringback is a useful safety feature to remind the user that the muted alarm is still active. Whenever there is an active alarm state, the red LED will flash for the entire duration of the alarm. There are 7 ringback durations available:

Home > Settings > System > Alarms/Sound > Alarm Controls > Ringback

Settings	Definition
Off	Disables ringback. If an alarm is muted, the alarm remains muted for the entire duration of the alarm event.
10s	A muted alarm will ringback audibly after 10 seconds if the unit is still in an active alarm state. This is the default setting.*
30s	A muted alarm will ringback audibly after 30 seconds if the unit is still in an active alarm state.
1min	A muted alarm will ringback audibly after 60 seconds if the unit is still in an active alarm state.
5min	A muted alarm will ringback audibly after 5 minutes if the unit is still in an active alarm state.
10min	A muted alarm will ringback audibly after 10 minutes if the unit is still in an active alarm state.
60min	A muted alarm will ringback audibly after 60 minutes if the unit is still in an active alarm state.

Backlight Dimming

Brightness is adjusted via the left and right arrows. Actual screen brightness adjusts immediately as the setting is changed. The Enter button will save the brightness setting, and cancel will leave the setting unchanged.

A timer is reset each time the screen is pressed. If that timer reaches the "Auto-Dim Time" the screen will dim. When the screen is pressed again, the screen will return to its original brightness setting. The lowest dimness setting will not allow the screen to turn completely dark, instead just enough to still be readable. Dim times are [1, 2, 5, 10, 60] minutes, with an "Off" setting, and a default time of 10 minutes initially.

Home> Settings>System>Brightness

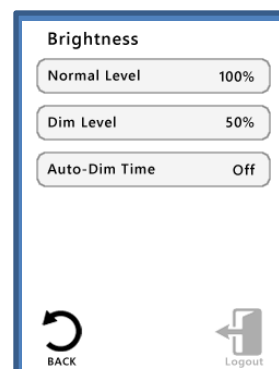

Latch Alarm

Alarm latching indicates that an alarm state was triggered even if the device is no longer in an active alarm state. This could occur when a user has stepped away from the workstation. When latching is "On", a yellow banner will display beneath the velocity and temperature readings on the home screen to indicate that a low airflow event has occurred. When latching is set to "Password", an EH&S passcode must be entered to unlatch this alarm. If the Latch alarm setting is set to "On", tap the banner to disable the alarm. Setting Alarm Latch to "Off" disables this feature entirely.

Home> Settings>System>Alarms/Sound>Alarm Controls>Latch Alarm

Alarm Delay

To prevent nuisance alarms or premature recoveries, users can define the amount of time that the Rooster™ Monitor100 has to achieve continuous safe velocity readings before the alarm state is cleared and continuous unsafe velocity readings before an alarm is triggered. This is called Alarm Delay.

Alarm Delay	Definition
1s	Alarm is cleared after 1 second if velocity readings are above the alarm clear threshold. Alarm is triggered after 1 second if velocity readings are below the alarm trip threshold. This is the default setting.
2s	Alarm is cleared after 2 seconds if velocity readings are above the alarm clear threshold. Alarm is triggered after 2 seconds if velocity readings are below the alarm trip threshold.
5s	Alarm is cleared after 5 seconds if velocity readings are above the alarm clear threshold. Alarm is triggered after 5 seconds if velocity readings are below the alarm trip threshold.
10s	Alarm is cleared after 10 seconds if velocity readings are above the alarm clear threshold. Alarm is triggered after 10 seconds if velocity readings are below the alarm trip threshold.

Startup Delay

The startup delay prevents an alarm from triggering until the workstation and ventilation systems have fully powered up and are operational. Refer to chart on next page for further definitions.

Alarm Delay	Definition
30s	Alarm is paused for 30 seconds on power up.
1 min	Alarm is paused for 1 minute on power up.
2 min	Alarm is paused for 2 minutes on power up.
5 min	Alarm is paused for 5 minutes on power up.

Airflow Resolution

For advanced users, displayed velocity units can be configured to display in an alternate resolution. The default resolution for units is 1 fpm and .01 m/s respectively. For users who prefer a more uniform readout, this can be configured up to 5 fpm or .05 m/s.

Home>Settings>System>Airflow Settings>Airflow Resolution

Airflow Resolution	Definition
1 fpm	Displayed units in FPM are rounded to 1 fpm. This is the default setting.
2 fpm	Displayed units in FPM are rounded to 2 fpm.
5 fpm	Displayed units in FPM are rounded to 5 fpm.
.01 m/s	Displayed units in m/s are rounded to .01 m/s. This is the default setting.
.02 m/s	Displayed units in m/s are rounded to .02 m/s.
.05 m/s	Displayed units in m/s are rounded to .05 m/s.

Airflow Sensitivity

This setting smooths airflow readings by applying a filter that determines “sensitivity” of readings.

Home>Settings>System>Airflow Settings>Sensitivity

Sensitivity	Definition
Low	Decreases filtering, resulting in greater fluctuation of readings, but faster response
Med	Default setting. Provides a balance between smooth readings and reasonable response times.
High	Increases filtering, providing smoother readings, but slows response

I/O Polarity

For advanced users, it may be helpful to toggle relay and input nodes from normally closed to normally open. The default state of normally closed is used to denote an alarm. If the alarm state is required to be an open relay, then toggle the output on the Monitor 100.

For example: The Sash Alarm and Airflow Alarm are configured by default to alarm when the relay is closed. If these are toggled to Normally Open, then this logic is reversed.

Home>Settings>System>Advanced>I/O Polarity

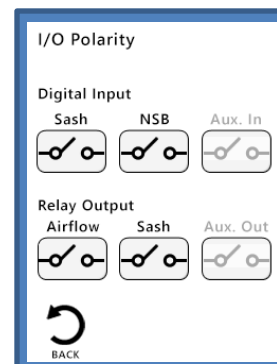

USB Field Upgrade Procedure

Procedure to field upgrade Rooster™ Monitor100 Operating System

You will need: USB thumb drive with new firmware "Rooster.bin"
Rooster™ Monitor100

Procedure:

1. Remove power from the Rooster™ Monitor100 by unplugging power supply.
2. Insert USB thumb drive into left side of Rooster™ Monitor100.
3. Depress and hold "Home" button, while reapplying power to your unit. (*Hard Home button must be depressed while Rooster™ powers up to enter the firmware update sequence*)
4. After ~3 seconds, release Home button. After 10 seconds, the LED on the front of the Rooster™ will light and the unit will boot up with new Firmware.
5. When the Field Upgrade Procedure is completed, navigate to the info [] screen from home to validate that the new firmware version was properly installed. The date of the firmware release – listed next to "firmware" - should have changed to the most current build. If this is not the case, repeat steps 1-5.

Factory Reset Procedure

The Factory Reset will return the Rooster™ Monitor100 to its default alarm & input/output settings. Time and date will be preserved. Factory Reset Procedure can be done at any time upon system reset to restore default settings and passwords.

Note: Calibration settings will be lost upon successful factory reset.

1. When the 1st information screen displays, momentarily press the "Mute" key.
2. The "Enter Factory Password" screen will display. Factory Password is "5878" and cannot be changed.
3. Factory Menu will display. Depress "Reset to Factory Defaults"
4. Unit now requires recalibration. Follow this menu path to perform a new calibration:
Settings>Calibration>Calibrate

Factory-default Certifier password is "6425"

GUI Map

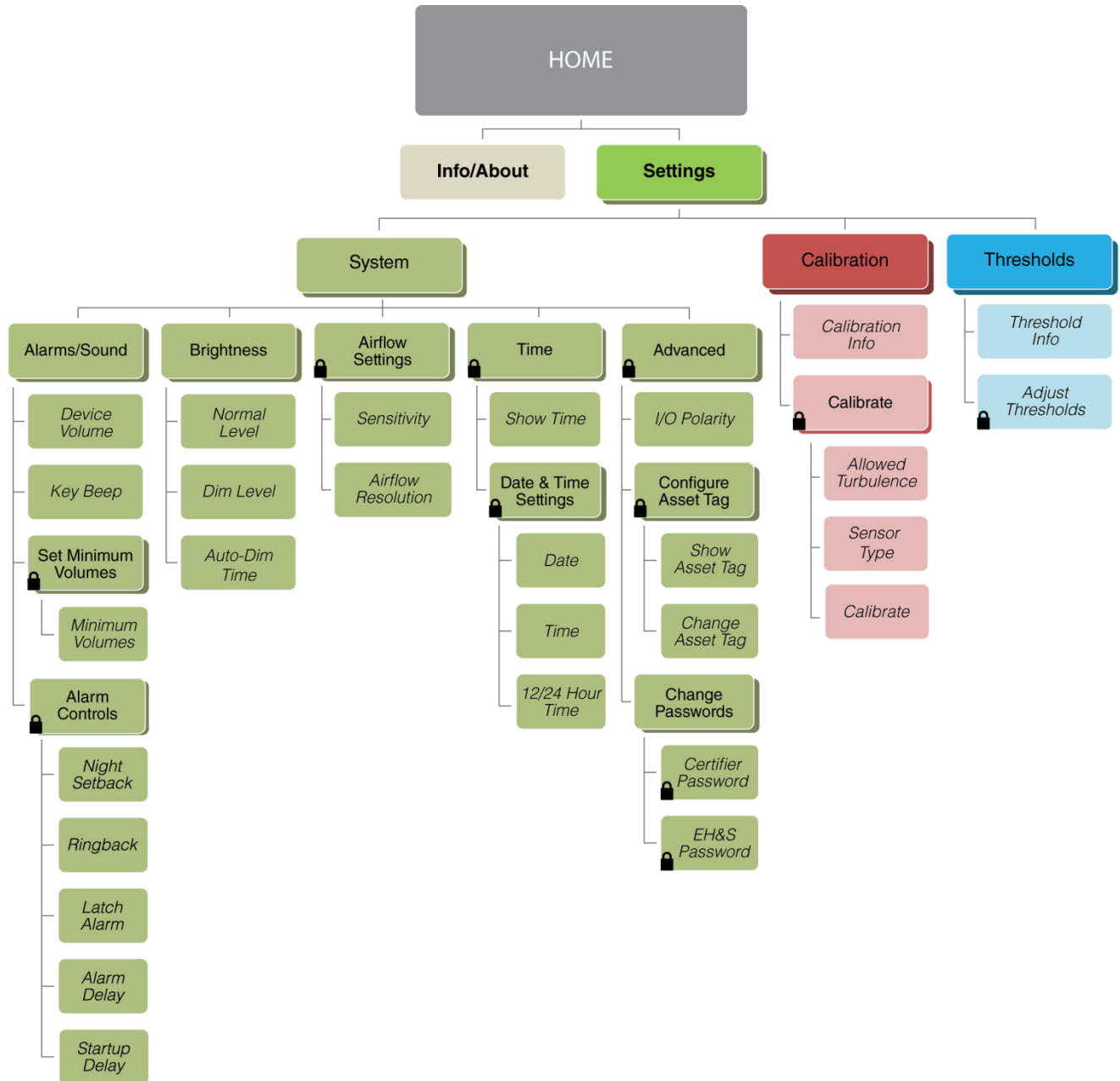

WARRANTY

The Rooster™ Monitor100 is warranted to be free from defects in workmanship and materials for a period of one (1) year from receipt. Degree Controls will at its option replace or repair defective parts within the warranty period. Damage resulting from misuse, wear and tear, and tampering is not covered by the warranty.

