

# TouchAmerica

The TouchAmerica Retrofit 'Wood Conversion Plate' is designed to convert an existing portable massage table to accept the new TouchAmerica 'Plug-in Face Space'

## Tools Needed:

Phillips Screwdriver  
3/8" wrench or socket & ratchet  
Electric drill  
3/8" drill bit  
Razor or 'Exacto' knife

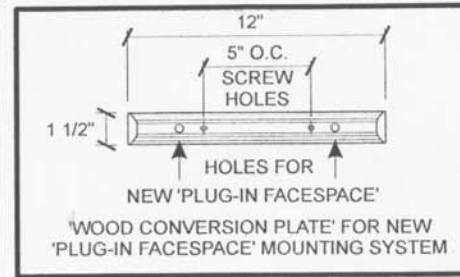
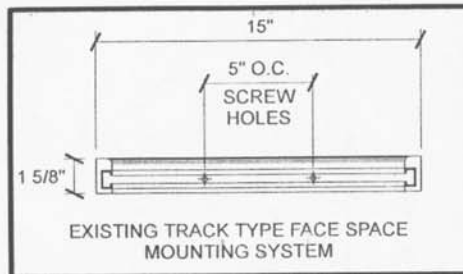

## Parts provided with kit:

- (1) 'Plug-in' Face Space Adj. Rig
- (2) Wood Conversion Plate
- (4) 3/16" x 2-1/2" flat head Phillips screws
- (4) 3/16" hex nut
- (4) Large washers

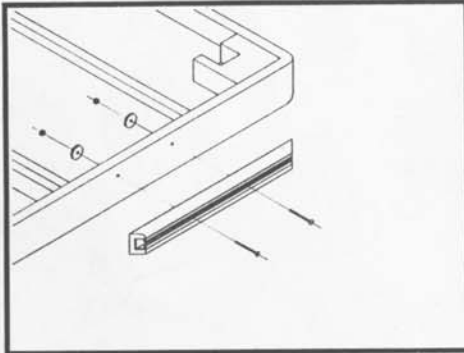

Remove existing mounting plate and screws from the massage table and discard.

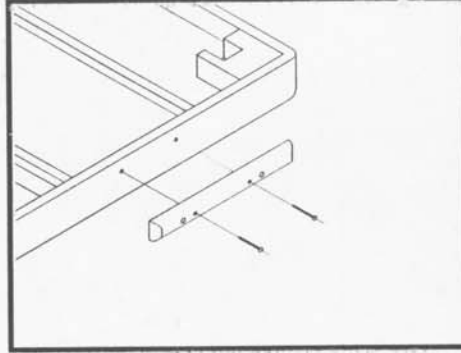

Position the 'Wood Conversion Plate' on the end of the Massage Table by inserting the screws through the existing holes.

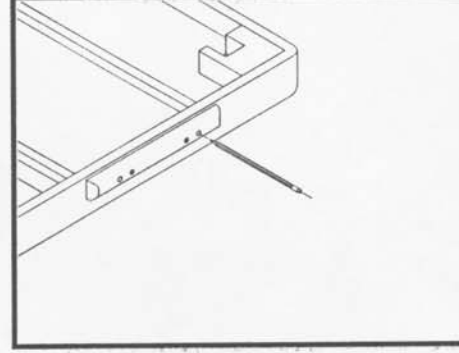

While holding the 'Wood Conversion Plate' in place, use a pencil or pen to mark the location of the large holes in the 'Wood Conversion Plate' on the end of the Massage Table.

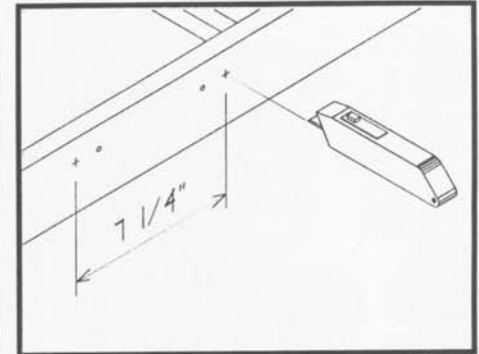

Remove the 'Wood Conversion Plate'. Use a knife to cut a small "X" in the vinyl at the pencil marks you just made on the end of the massage table.

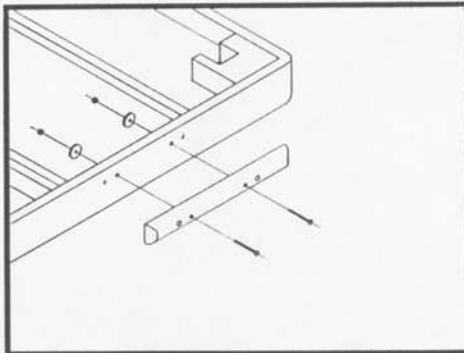

Using the large washers and 3/16" hex nut, secure the 'Wood Conversion Plate' to the end of the table. Before tightening make sure plate is positioned parallel to the bottom edge of the massage table.

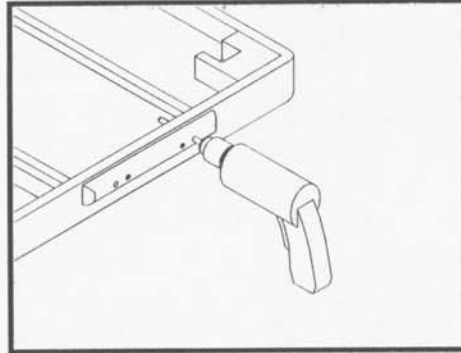

With the drill & 3/8" drill bit, drill holes completely through the end of the massage table using the outer holes in the 'Wood Conversion Plate' as a guide. Be sure to hold the drill as level and straight as possible so the new 'Plug-in Face Space' will adjust properly.

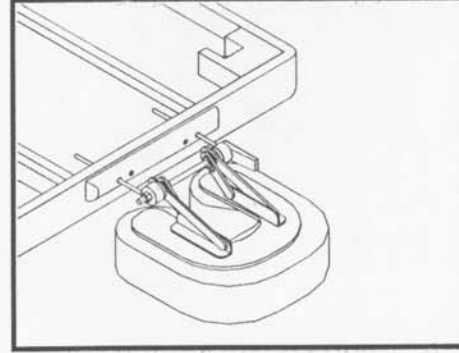

Line up the steel rods from the new 'Plug-in Face Space' with the 3/8" holes that you just drilled to check for a proper fit.

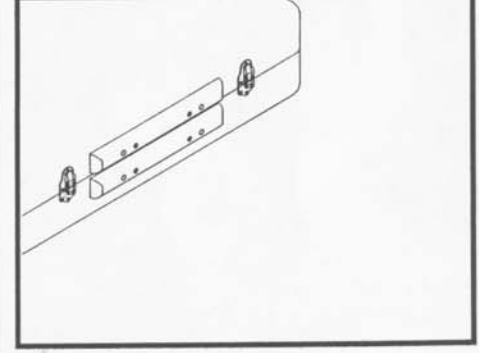

Repeat procedure for other end of massage table and relocate existing clasps as needed to complete the retrofit procedure.