



*presents*

# *Nightingales*

*by Jeff Bagby*

The Nightingales are a high-end stand mounted speakers of exceptional quality. Both the Wavecor WF182BD midwoofer and the SB Acoustics SB29SDAC tweeter offer world class performance, with very linear response and extremely low distortion.

The crossover was designed as an acoustic fourth order LR type crossover that is internally phase adjusted for proper phase alignment.

The crossover point is a 1.8 kHz, and the response is very flat. The impedance is very stable as well. This is an 8 ohm nominal speaker with a minimum impedance of 6.4 ohms. So any amp should be happy driving the Nightingales.

The vented cabinet is tuned to 38 Hz, resulting in a half space -3 dB point of 38 Hz and a -6 dB point of 35 Hz in a .6 cubic foot (17L) enclosure.

The Nightingales are an honest, high resolution loudspeaker, of remarkably low distortion. They are sure to please the most critical audiophile who is looking for a small stand-mounted speaker that truly delivers solid high-end sound reproduction.

The Nightingales would be just as comfortable in a recording studio as they would be in a living room.

*Jeff Bagby*



**RAD**  
RHYTHM AUDIO DESIGN

*presents*

# Nightingales

*by Jeff Bagby*

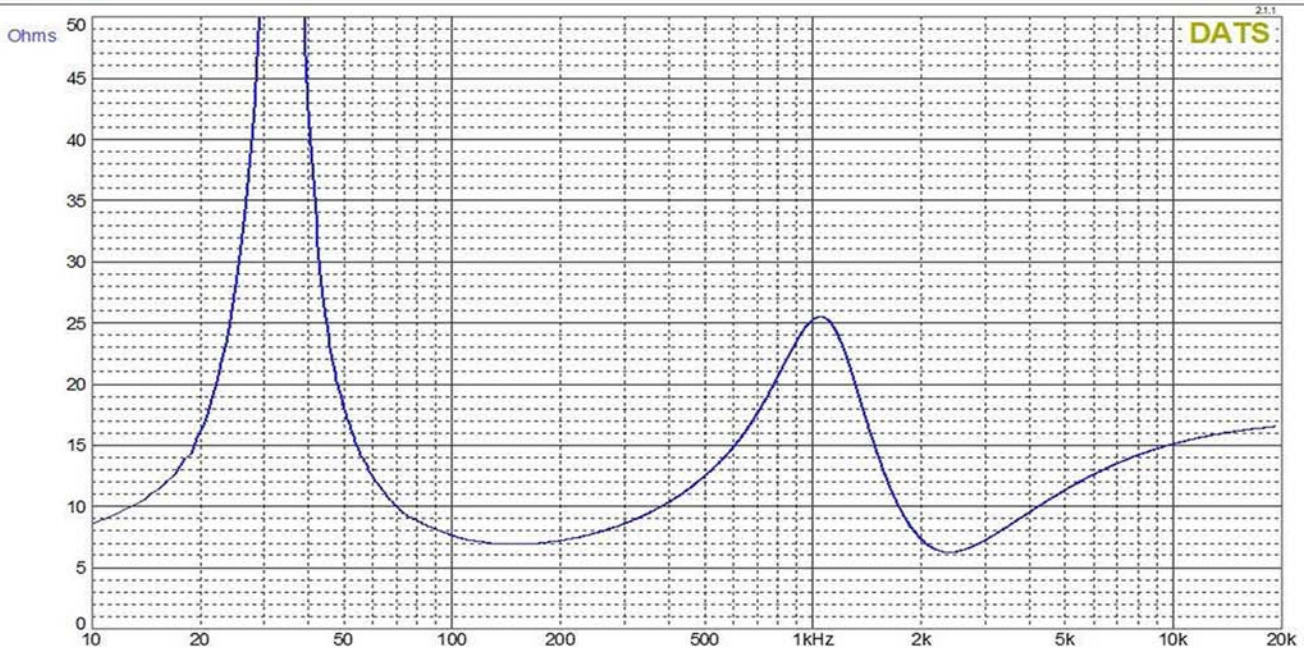
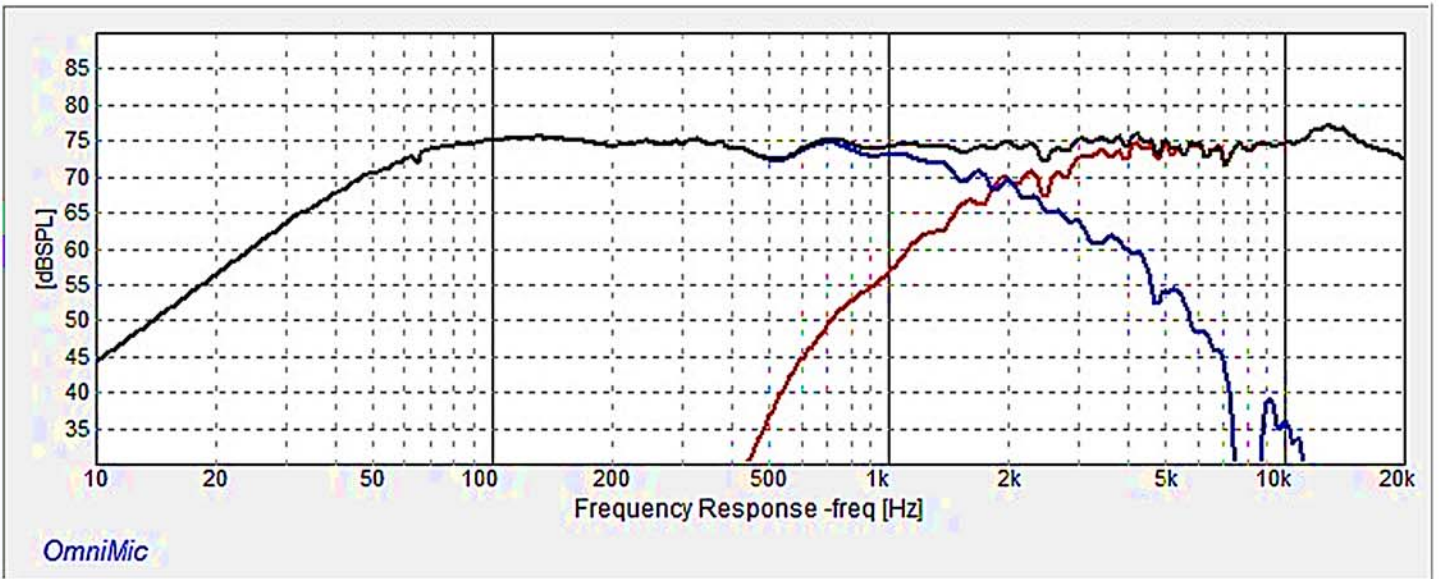



**RAD**  
RHYTHM AUDIO DESIGN

*presents*

# Nightingales

*by Jeff Bagby*

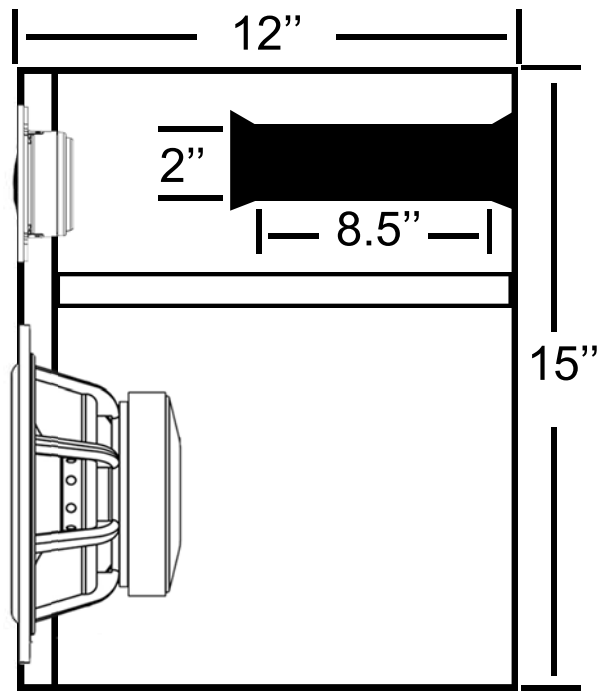
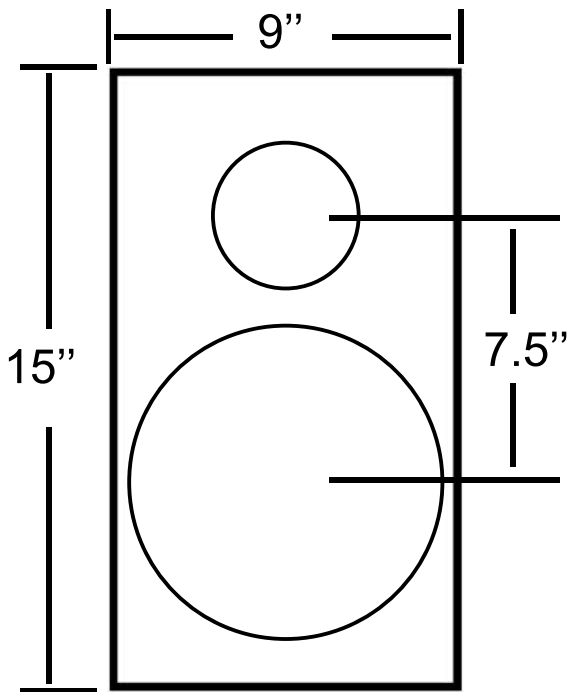



**RAD**  
RHYTHM AUDIO DESIGN

*presents*

# Nightingales

*by Jeff Bagby*

Tweeter

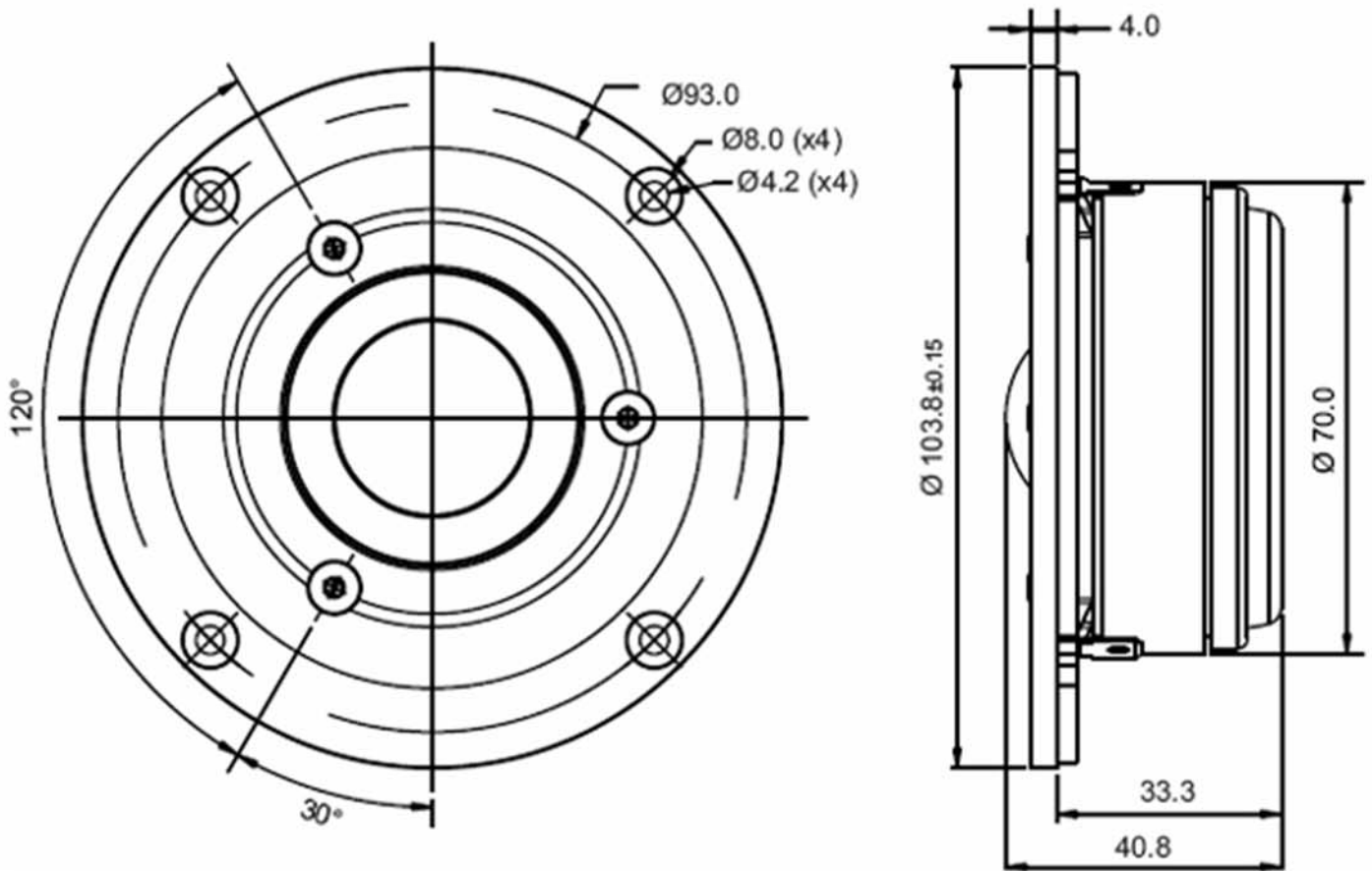



**RAD**  
RHYTHM AUDIO DESIGN

*presents*

# Nightingales

*by Jeff Bagby*

## Woofer

**OUTLINE DRAWING**  
(nominal dimensions, mm)

