



KingsBottle™

INSTRUCTION MANUAL

Wine Cellar

PLEASE READ THIS MANUAL CAREFULLY BEFORE INSTALLING AND OPERATING.

Important Note: Upper zone must be set 4°F colder than lower zone.

TABLE OF CONTENTS

Contents	Page #
Diagram & Description of Wine Cellar	4
Important Safety & Pre-Use Instructions	5
Installation Instructions	
(a) General Installation Instructions	5
(b) Installation of Unit as a Built-In Cellar	5
(c) Reversing Door Swing	7
Operating Your Wine Cellar	9
Temperature Settings for Serving Wine	10
Door Lock	11
Layout & Storage	11
Removing the rolling shelf	11
Care & Maintenance	12
Troubleshooting Guide	13
Warranty	14

DIAGRAM & DESCRIPTION OF WINE CELLAR

KBU-145D

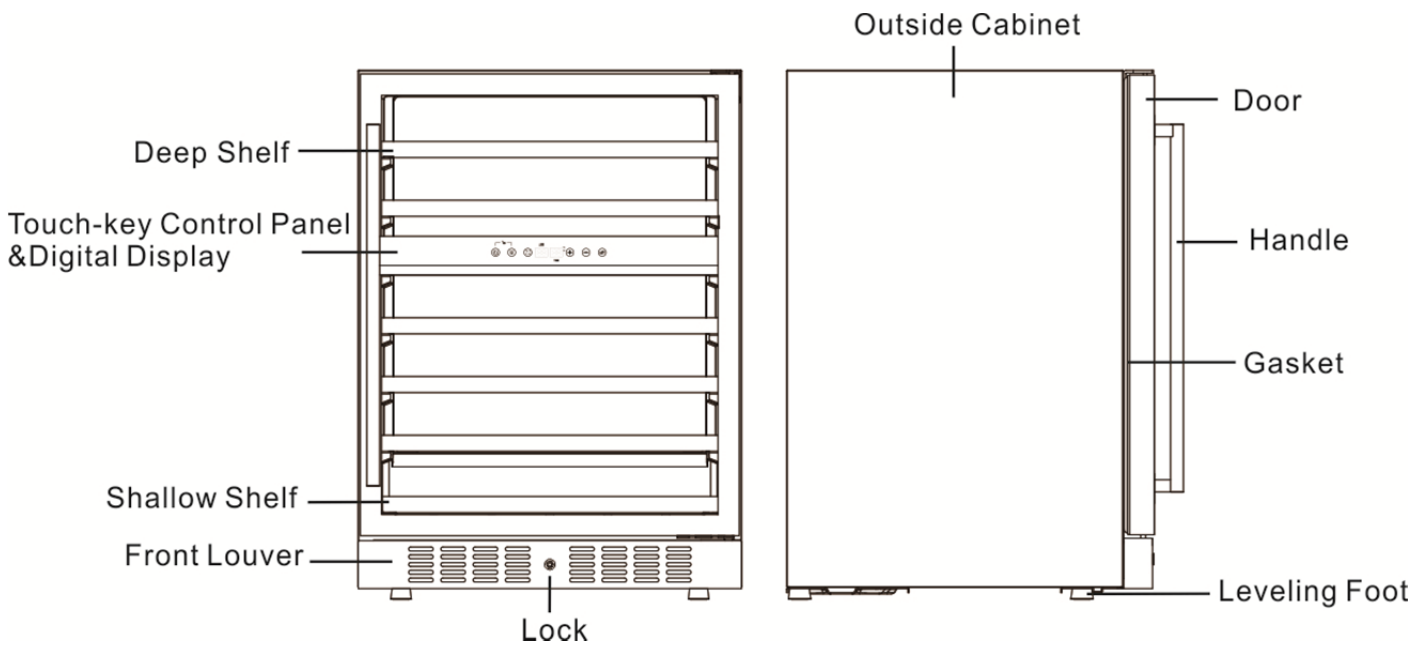

KBU-270D

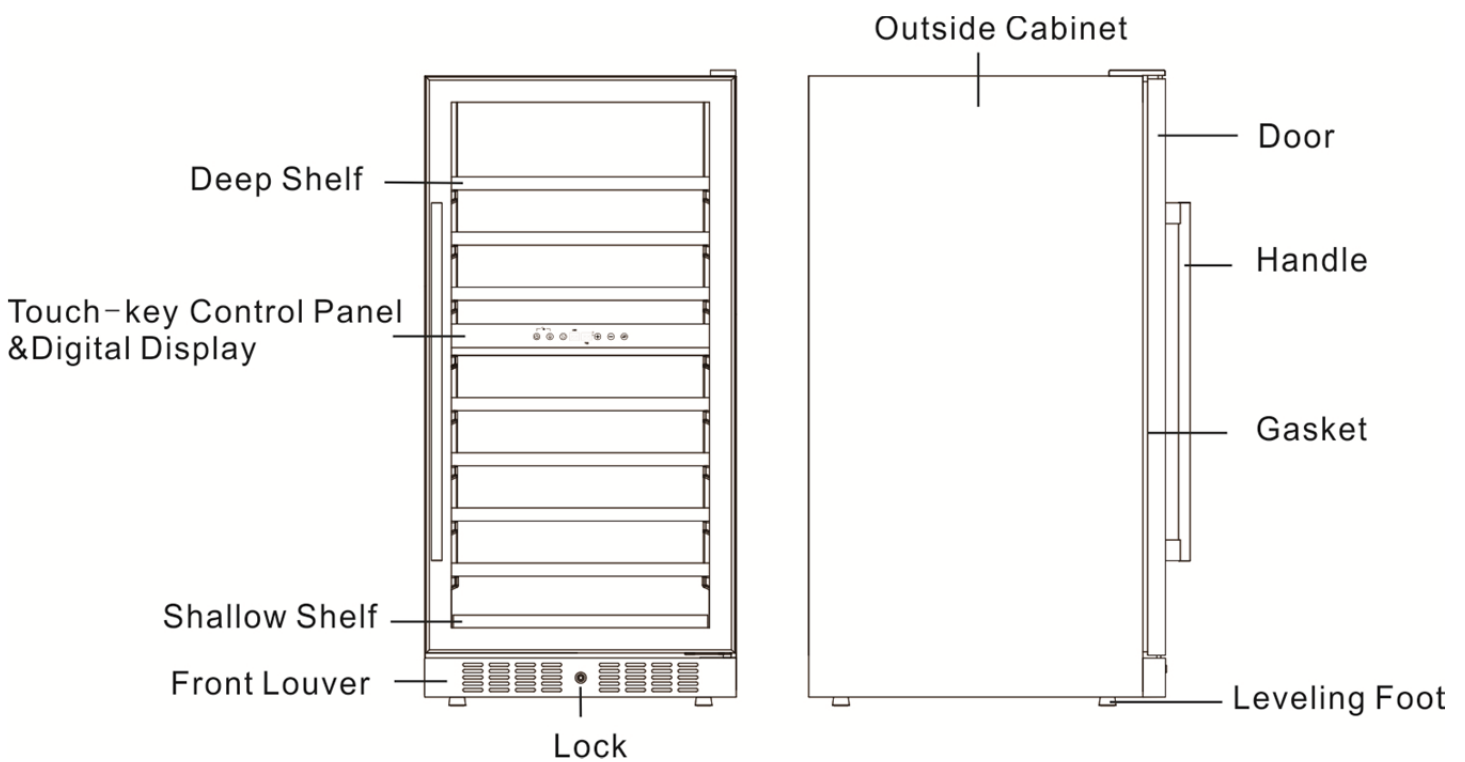

KBU-428D

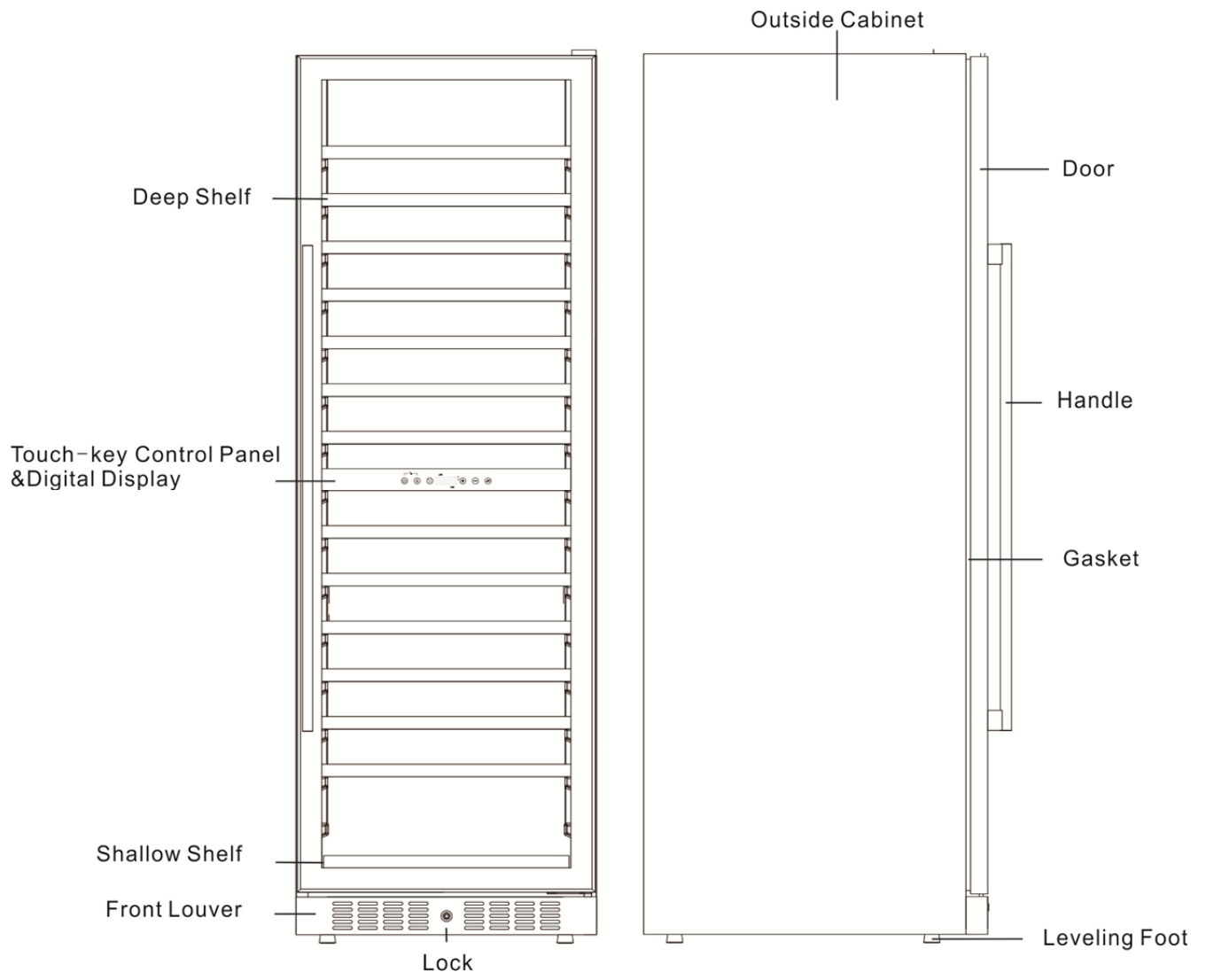

IMPORTANT SAFETY & PRE-USE INSTRUCTIONS

WARNING	To reduce the risk of fire, electrical shock, or injury when using your appliance, follow these basic precautions:
<ul style="list-style-type: none">● Read all instructions before using the wine cellar.● DANGER: Risk of child becoming trapped in new cellar, old wine cellar/refrigeration unit, or large boxes. Junked or abandoned appliances, boxes and other containers are still dangerous, even if they will “just sit in the garage for a few days”.● Before you throw away your old wine cellar or refrigeration unit: 1. Take off the door. 2. Leave the shelves in place so that children cannot climb inside.● Never allow children to operate, play with, or crawl inside the appliance.● Never clean appliance parts with flammable fluids. The fumes can create a fire hazard or explosion.● Do not store in the vicinity of any other appliance. Do not store near gasoline or any other flammable vapors. The fumes can create a fire hazard or explosion. <p style="text-align: center;">-Save these instructions-</p>	

BEFORE USING YOUR WINE CELLAR

- Remove the exterior and interior packaging.
- Before connecting the wine cellar to the power source, let it stand upright for approximately **2** hours. This will reduce the possibility of a malfunction in the cooling system from handling during transportation.
- Clean the interior surface with lukewarm water using a soft cloth.

INSTALLATION INSTRUCTIONS

(a) General Installation Instructions

- This appliance is designed for free standing installation or can be recessed into cabinetry.
- Place your wine cellar on a flat, solid floor that is strong enough to support it when it is fully loaded. To level your wine cellar, adjust the front leveling leg at the bottom of the wine cellar.
- When moving your wine cellar, please do not incline it more than 45 degrees.
- Locate the wine cellar away from direct sunlight and sources of heat (stove, heater, radiator, etc.). Direct sunlight may affect the acrylic coating and heat sources may increase electrical consumption. Extreme cold ambient temperatures may also cause the unit to perform improperly.
- Avoid locating the unit in damp areas.
- Plug the wine cellar into a dedicated (for this appliance only), properly installed and grounded wall outlet. Do not under any circumstances cut or remove the third (grounding) prong from the power cord. Any questions concerning power and/or electrical grounding should be directed to a certified electrician or authorized product service center.

(b) Installation of Unit as a Built-In Cellar

The cutout dimensions illustrated below allows for door clearance and access to the pull-out shelves when installed as a built-in appliance.

Your wine cellar has been manufactured with a zero clearance door so no extra space is required to account for the door swing when building into cabinetry.

KBU-145D

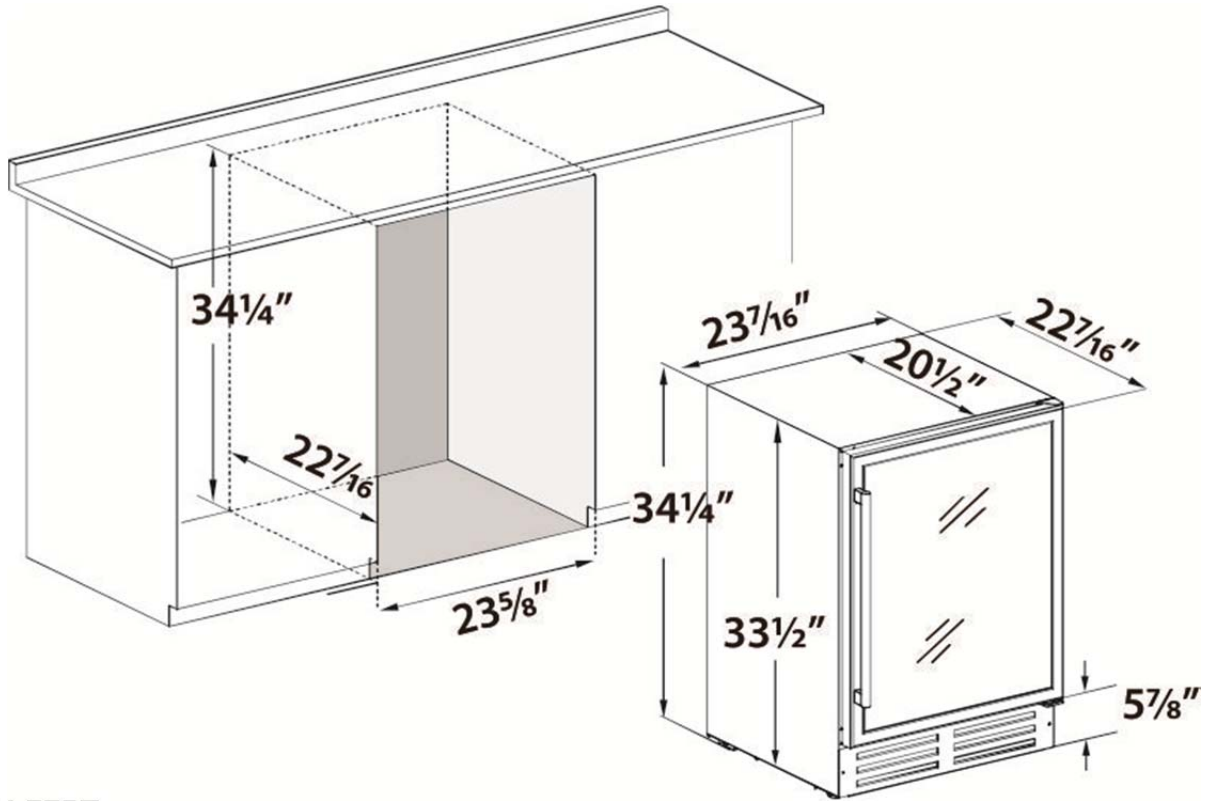

KBU-270D

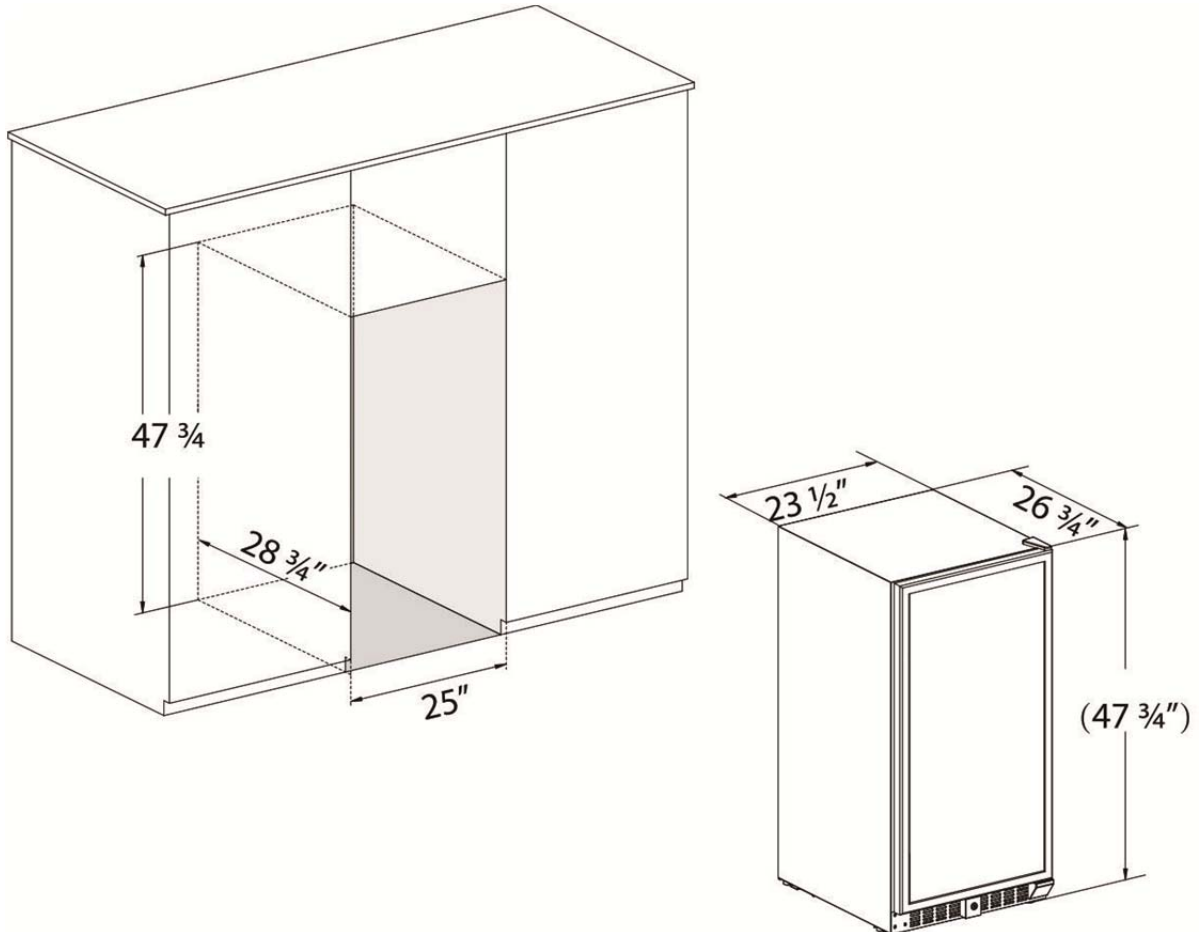

KBU-428D

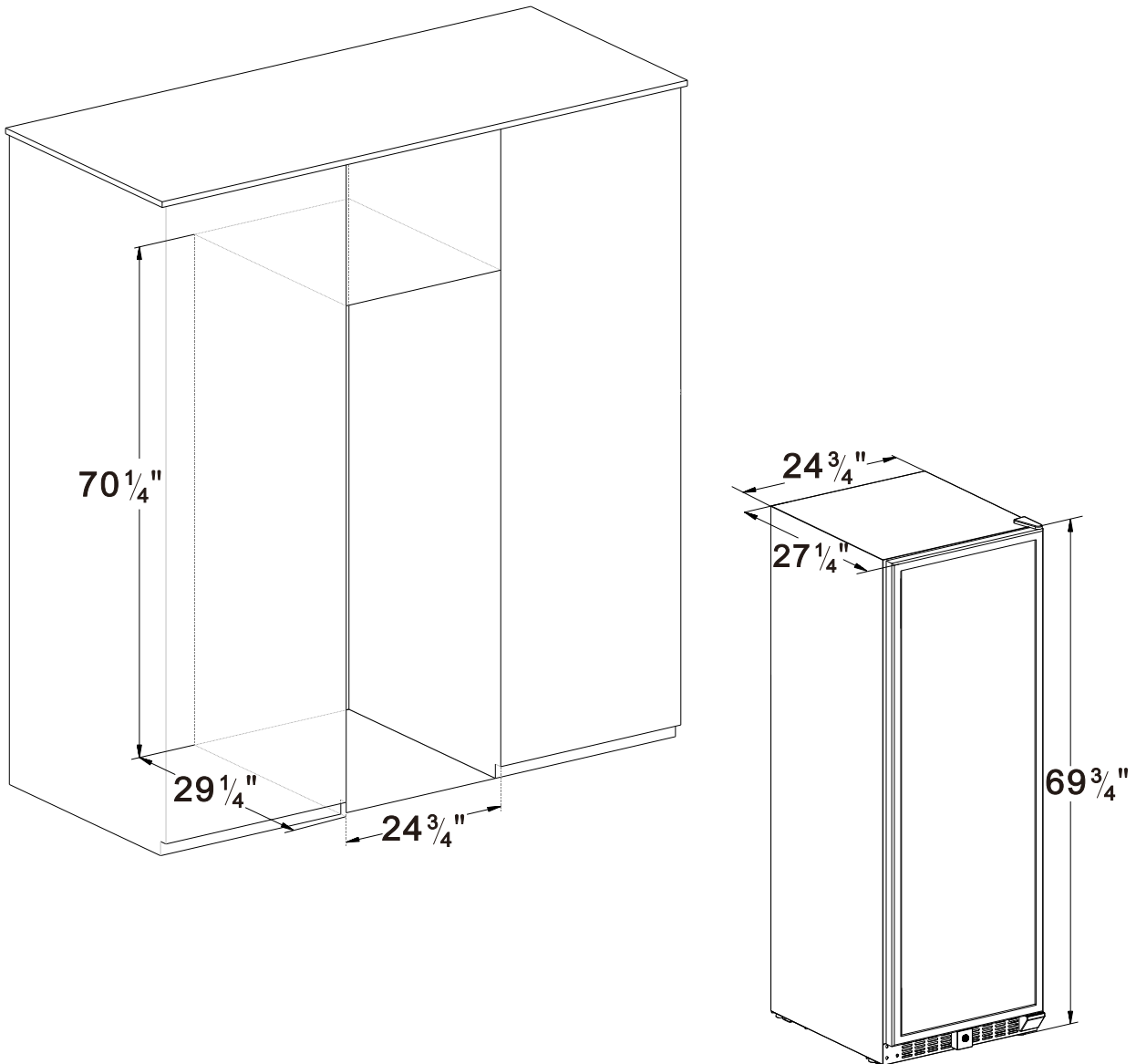

These cut out dimensions show the minimum space required for your wine cellar to perform as designed.

Note: If your cabinets are less than $34\frac{3}{4}$ " in height, you can remove the leveling legs on the bottom of the wine cellar to reduce its height by $\frac{1}{2}$ ". You must use shims to level the wine cellar if you remove the leveling legs.

(c) Reversing the Door Swing of Your Appliance

Before you begin: Tape down shelves to avoid movement during the process

- The unit may have been delivered to you with the door opening from the left side (hinges on the right).
- The door of this appliance can be hung to open on the left or right side. To reverse the door swing of your cellar and open from the opposite side, please follow the instructions and diagram below.

1. Open the door, and loosen the screws from the support rod of the bottom hinge.

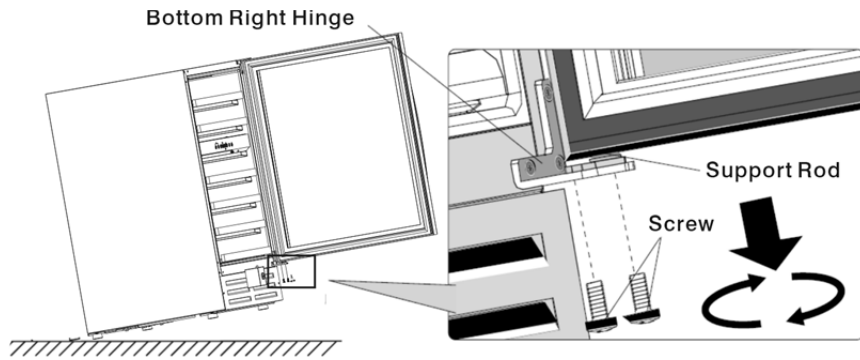

2. Remove the door off the upper hinge and take out the support rod.

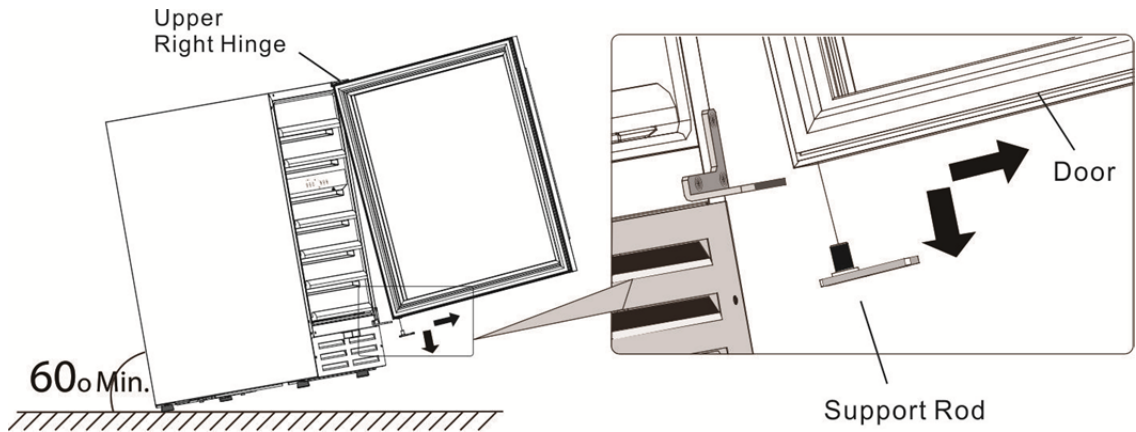

3. Use a small flat head screwdriver to pry up the lock hole cap on the top of the door and remove to the bottom.

4. Unscrew the upper hinge and bottom hinge.

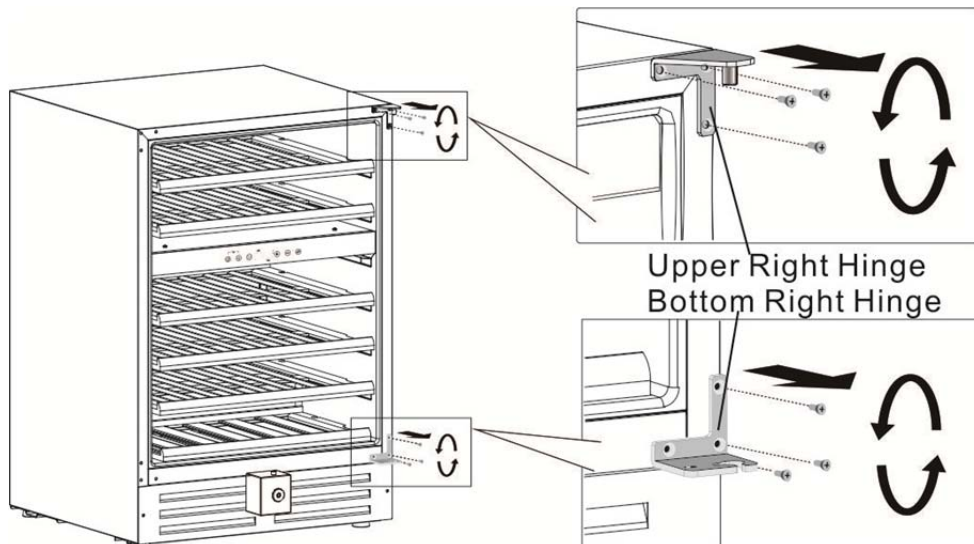

5. Pry out the plastic caps at the left side of the cabinet, and remove them to the right side.

6. Install the hinge set which are packed as accessories with the instruction manual to the opposite side.

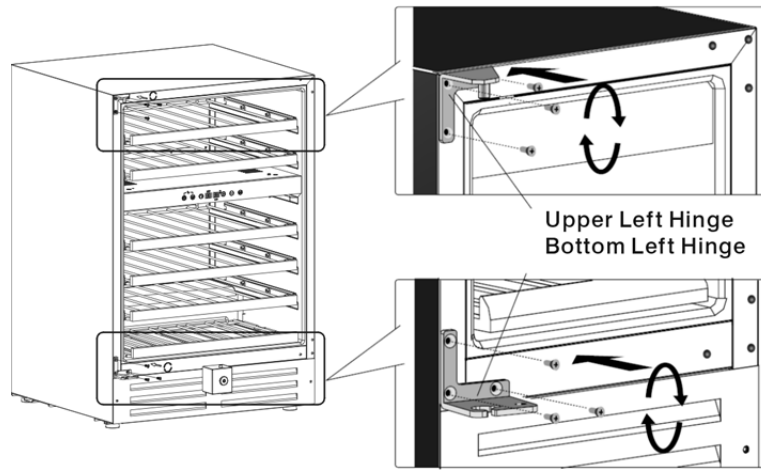

7. Rotate the door 180° so that the top is now the bottom, and install it by attaching the support rod with screws.

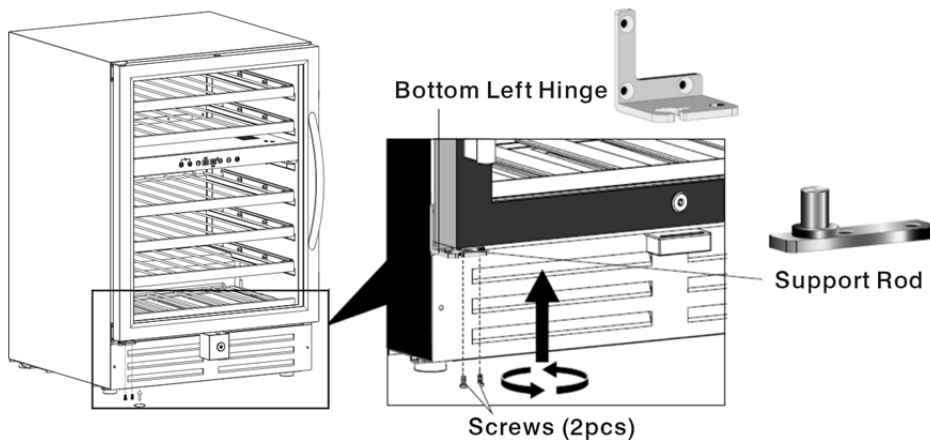

Stainless steel doors include a handle centered in the middle of the door. There is no need to alter the location of the handle.

Glass doors include integrated door pull handles. There is no need to alter the location of door pull handles.

OPERATING YOUR WINE CELLAR

Each wine cellar includes an operating panel on the front of the unit. This operating panel includes several features to operate and control the temperature of both the UPPER and LOWER zones of the wine cellar. The operating panel includes the following features:

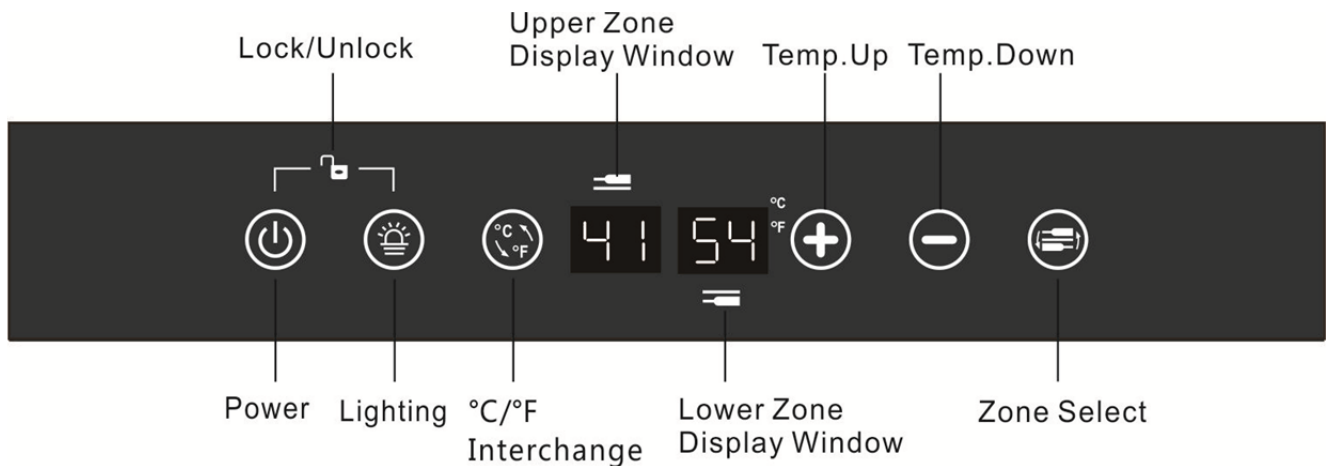

Power:	Turns the wine cellar system on or off.
Lighting:	Turns the interior wine cellar light on or off.
Power/Lighting:	Lock/Unlock button.
°C/°F:	Alters the temperature display to Fahrenheit or Celsius
Upper Zone Display Window:	Displays temperature of upper zone.
Lower Zone Display Window:	Displays temperature of lower zone.
Temp. Up:	Increases temperature by 1°.
Temp. Down:	Decreases temperature by 1°.
Zone Select:	Switches temperature control between upper and lower zone.

BEFORE YOU START: The wine cellar should be placed in a location where the ambient temperature is between 60-80° Fahrenheit. If the ambient temperature is outside this range, the performance of the unit may be affected. For example, placing your unit in extreme cold or hot conditions may cause interior temperatures to fluctuate.

IMPORTANT: IN ORDER FOR THIS UNIT TO FUNCTION AT OPTIMUM LEVEL, THE UPPER COMPARTMENT SHOULD BE SET AT LEAST 4-DEGREES (F) COLDER THAN THE LOWER COMPARTMENT.

Lock/Unlock

Your wine cellar includes a feature that will lock the control panel when if left untouched for 10 seconds. To unlock the wine cellar control panel touch the power and lighting buttons simultaneously for 3 seconds.

Setting Temperature

1. Make sure power cord is connected to a properly grounded outlet.
2. Turn power ON.
3. Press the zone select button to choose the “UPPER” or “LOWER” zone. Each zone is independently controlled.
 - **Upper Zone:** The temperature setting can be adjusted from 41°F to 54°F
 - **Lower Zone:** The temperature setting can be adjusted from 46°F to 66°F
4. Set the desired temperature of the UPPER or LOWER zone pushing the **UP (+)** or **DOWN (-)** button.
5. Temperatures increase or decrease 1°F with each push of the **UP (+)** or **DOWN (-)** button.

NOTE:

Temperatures may fluctuate depending on whether the interior light is ON or OFF and depending on the position of the bottles.

TEMPERATURE SETTINGS FOR SERVING WINE

Although optimal storage temperature is generally regarded to be 53-57°F, different varietals of wine have different recommended serving temperatures for optimal taste. The recommended temperature ranges for serving different varietals of wine are listed below.

- Red Wines: 60-66°F
- White Wines 45-52°F
- Sparkling Wines 40-45°F

NOTE:

- In the event of a power interruption, your wine cellar will revert back to the factory settings, 41° F in the upper cabinet and 46° F in the lower cabinet, once power is restored.
- If the unit is unplugged, loses power, or is turned off, you must **wait 3 to 5 minutes before restarting**. Attempting to restart the wine cellar before this time has elapsed may prevent the wine cellar from starting.
- When you use the wine cellar for the first time or restart the wine cellar after having been shut off for a long time, there will be a few degrees variance between the temperature you select and the one indicated on the LED readout for the first few hours of operation. After a few hours of operation, the temperature will normalize to the displayed temperature.

DOOR LOCK

- This unit comes with a key lock.
- The keys are located inside the plastic bag that contains the instruction manual. To unlock the door, insert the key into the lock and turn counter clockwise.
- To lock the door, simply reverse the operation making sure the metal pin is engaged completely. Then remove the key and place it in a secure place for safekeeping.

LAYOUT AND STORAGE

Your cabinet was designed to store a maximum number of bottles securely. We recommend that you observe the tips below to optimize loading.

- Remove tape from shelves once unit is stable and ready for storage.
- Disperse the bottles evenly to avoid concentrating weight in one place. Bottles must not touch either the back of the cabinet or the step at the bottom. While your wine cellar was designed to hold large format bottles such as Pinot Noir and Champagne, these larger bottles reduce the number of bottles you can fit on 1 shelf. Make sure that the bottles are not all grouped together either at the top or bottom of the cabinet. Bottles dispersed evenly throughout the cabinet will contribute to optimal cooling.
- Only pull out one rolling shelf at a time. Never attempt to pull more than one.
- Maximum weight capacity per shelf is 55 lbs.
- Each rolling shelf is designed to comfortably hold one row of 11-13 bottles.

REMOVING THE ROLLING SHELF

To remove a telescopic shelf:

1. Remove all bottles.
2. Pull out the shelf to align the shelf grooves to the stoppers fixed on the inside cabinet.
3. Push upward the shelf from the telescopic rails and remove it carefully.

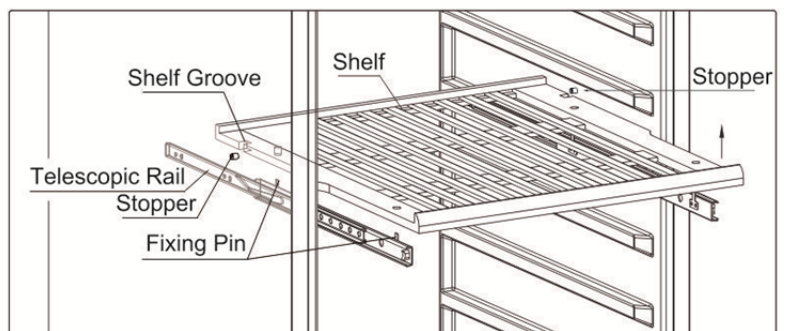
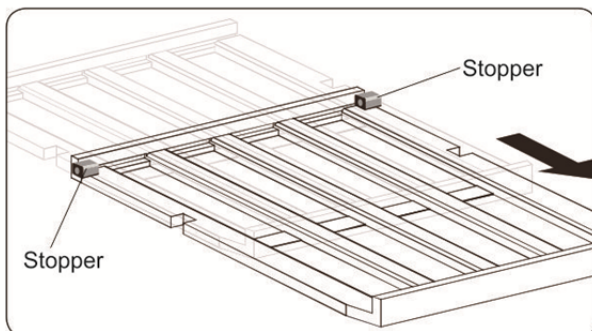

CARE AND MAINTENANCE

Cleaning Your Wine Cellar

- Turn off the power, unplug the appliance, and remove all items including all shelves.
- Wash the inside surfaces with a solution of warm water and baking soda (approximately 2 tablespoons of baking soda for each quart of water.)
- Wash the shelves with a mild detergent solution.
- Wring excess water out of the sponge or cloth when cleaning area of the controls, or any electrical parts.
- Wash the exterior with warm water and mild liquid detergent. Rinse well and wipe dry with a clean soft cloth.
- Vacuum the front grill and back of the unit twice yearly. Make sure the power is off before cleaning.
- It is recommended to clean the unit completely inside and out once a year to maximize the longevity of the wine cellar.

Power Loss

- Power failures that are corrected within a few hours should not affect the temperature of your appliance if you minimize the number of times the door is opened. If the power is going to be off for a longer period of time, you need to take other measures to protect your contents.
- If the unit is unplugged, loses power, or is turned off, you must **wait 3 to 5 minutes before restarting**. Attempting to restart the wine cellar before this time has elapsed may prevent the wine cellar from starting.

Absence/Vacation

- **Short vacations:** You may leave the wine cellar powered on and unattended for absences of less than three (3) weeks.
- **Long vacations:** If the appliance will not be used for more than three weeks, remove all items and turn off the appliance. Clean and dry the interior thoroughly. To prevent mold growth, leave the door open slightly, blocking it open if necessary.

Moving Your Wine Cellar

- Remove all items.
- Securely tape down all loose items (shelves) inside your appliance.
- Turn the adjustable leg up to the base to avoid damage.
- Tape the door shut.
- Be sure the appliance stays secure in the upright position during transportation. Also protect the outside of the appliance with a blanket or similar item.

Energy saving Tip

- The wine cellar should be located in the coolest area of the room, away from heat producing appliances, and away from direct sunlight.

TROUBLESHOOTING GUIDE

Many common issues with your wine cellar can be solved very easily. Try the troubleshooting tips below should you experience any problems

PROBLEM	POSSIBLE CAUSE
Wine cellar does not operate.	Not plugged in. The appliance is turned off. The circuit breaker tripped or a fuse has blown out.
Wine cellar is not cold enough.	Check the temperature control setting. External environment may require a higher setting. (e.g. room needs to be air conditioned) The door is opened too often. The door is not closed completely. The door gasket is not sealing properly.
Wine cellar is turning on and off frequently.	The room temperature is hotter than normal. The door is opened too often. The door is not closed completely. The temperature control is not set correctly. The door gasket does not seal properly.
The light does not work.	Not plugged in. The circuit breaker tripped or a fuse has blown. The light bulb has burned out. The light button is "OFF".
Vibrations.	Check to assure that the wine cellar is on a level surface.
The wine cellar seems to make too much noise.	A faint humming noise may come from the flow of the refrigerant, which is normal. As each cycle ends, you may hear gurgling sounds caused by the flow of refrigerant in your wine cellar. Contraction and expansion of the inside walls may cause popping and crackling noises. The wine cellar is not on a level surface.
The door will not close properly.	The wine cellar is not on a level surface. The door was reversed and not properly installed. The gasket is dirty. The shelves are out of position.
The area around the door, top, or side is hot.	Your wine cellar comes with a heating element near the door that keeps frost and condensation off the cabinet frame and it's normal for this area to feel warm. It will not affect the temperature inside the wine cellar.

WARRANTY

PART IX WARRANTY INFORMATION

Please speak to your Retailer before calling **BTO AMERICA LIMITED** (also known as **KingsBottle**) if you did not purchase your Beverage Cooler directly from BTO AMERICA LIMITED

Limited warranty – If your refrigerator is not operating, KingsBottle reserves the right to repair or replace the refrigerator. KingsBottle may request the consumer to contact a local refrigeration company to service the refrigerator. All cost for labor and materials is covered for 1 year from the date of receipt. If KingsBottle deems the unit not repairable, KingsBottle will use the value of your original order toward a replacement. For customer service, please contact **BTO AMERICA LIMITED** by e-mail (service@kingsbottle.com) .

The limited warranty does not cover: Damage due to such things as accident, misuse, abuse, mishandling, neglect, unauthorized repair or any other cause beyond the control of the seller whether similar or dissimilar to the foregoing. Purchaser understands and acknowledges that the goods sold here are Beverage Coolers, which house wine. Purchaser assumes all the risk of using these units, including risk of spoilage humidity variations, temperature variations, leaks, fires, water damage, mold, mildew, dryness and similar perils that may occur.

SPECIAL NOTE: Warranty is only honored for the unit which is purchased and used in United States of America. And, if your product was purchased at any 3rd party retailer and not directly from KingsBottle, we do not offer an extended warranty policy. You **MUST** contact the retailer of purchase directly. In the event your retailer does not offer an extended warranty plan, we recommend you contact a third party warranty provider. However, regardless of point of purchase, all KingsBottle coolers are backed by a ONE YEAR manufacturer's warranty from date of sale.



COMPRESSOR WINE COOLER

