

USER MANUAL

KBU-50DX / 100DX / 170DX DUAL ZONE WINE REFRIGERATORS



KBU50DX-FG

KBU100DX-FG

KBU170DX-FG

KBU170DX

KBU100DX

KBU50DX

BORDERLESS BLACK GLASS DOOR SERIES

GLASS DOOR WITH STAINLESS TRIM SERIES

PLEASE NOTE:

- Every time the unit is powered ON, there will be a 6-minute delay for the compressor to start.
- For optimal use of this product, the temperature of the LOWER cooling zone should be set to at least 4°F above the temperature of the UPPER cooling zone.

COMPRESSOR WINE COOLERS



CONTENTS

Congratulations

Congratulations and thank you for choosing our KingsBottle wine coolers. We are sure you will find your new appliance a pleasure to use. Before installing and operating the wine cooler, we recommend that you read through this manual which provides a description of your wine cooler and its functions.

To avoid the risks that are always present when you use an electric appliance, it is important that the appliance is installed correctly and that you read the safety instructions carefully to avoid misuse and hazards.

We recommend that you keep this instruction booklet for future reference and pass it on to any future owners.

After unpacking the appliance, please inspect it to verify it is not damaged. If in doubt, do not use the appliance but contact us or your local customer care center.

TABLE OF CONTENTS

Chapter	Contents	Page
Part I	Important Safety & Pre-Use Instructions	3
Part II	Diagram & Description of Refrigerator	4
Part III	Installation Instructions	5-7
Part IV	Layout & Storage	8-10
Part V	Temperature Setting and Operating the Refrigerator	11-12
PART VI	Maintenance Guide	13
Part VII	Troubleshooting Guide	14
Part VIII	Technical Data	16
Part IX	Warranty Information	16

Prop. 65 Warning for California Residents



WARNING

Cancer and Reproductive Harm -
www.P65Warnings.ca.gov

PART I IMPORTANT SAFETY INSTRUCTIONS

Please read this user manual carefully and store in a handy place for later reference. The symbols you will see in this booklet have these meanings:



This symbol indicates information concerning your personal safety



This symbol indicates information on how to avoid damaging the appliance



This symbol indicates tips and information about the use of the appliance



This symbol indicates tips and information about economical and ecological use of the appliance



TO REDUCE THE RISK OF FIRE, ELECTRICAL SHOCK, OR INJURY WHEN USING YOUR APPLIANCE, FOLLOW THESE BASIC PRECAUTIONS:

1. Read all instructions before using the wine cooler.
2. DANGER or WARNING: Risk of child entrapment. Child entrapment and suffocation pose a serious problem and children should not be let near the appliance unsupervised. Junked or abandoned appliances are still dangerous... even if they will "just sit in the garage for a few days."
3. Before you throw away your old wine cooler:
 - Take off the door.
 - Dismantle the Shelves into pieces so that children may not climb inside easily.
4. Never allow children to operate, play with, or crawl inside the appliance.



1. The wine cooler must be plugged into its dedicated 110-115V, 50/60Hz AC electrical outlet.
2. The plug must be accessible when the cooler is in position.
3. It is essential that the power point is properly grounded. Consult a qualified electrician if you are unsure.

4. Don't use extension cords or adapter plugs with this cooler.
5. If the power cord is damaged, have it replaced by a qualified service technician.
6. Unplug the cooler before cleaning it, or changing the light bulb to avoid electric shock.
7. Never clean appliance parts with flammable fluids. The fumes can create a fire hazard or explosion.
8. Never unplug the cooler by pulling the electrical cord as this may damage it. Grip the plug firmly and pull straight out.
9. Choose a location for your cooler that isn't too cold. The ambient room temperature should be above 50° F.
10. Stand your cooler in a dry place – avoid areas of high moisture or humidity.
11. Don't put the cooler in frosty or unprotected areas like a garage or on the verandah.
12. Keep the cooler out of direct sunlight.
13. Don't locate the cooler near stoves, fires or heaters.
14. Do not store in the vicinity of any other appliance. Do not store near gasoline or any other flammable vapors. The fumes can create an explosion or lead to a fire hazard.
15. When installed correctly, your cooler should:
16. Have adequate space at the back and sides for air circulation. (See Page 5)
17. Be aligned to the surrounding cupboards.
18. Have doors that will self-close from a partially open position
19. Please inspect and clean the filter in front venting grill every month. Failure to clean will void the warranty and increase the running costs.

BEFORE USING YOUR WINE COOLER

- Remove the exterior and interior packing.
- Before connecting the wine cooler to the power source, let it stand upright for approximately 24 hours. This will reduce the possibility of a malfunction in the cooling system from handling during transportation.
- Clean the interior surface with lukewarm water using a soft cloth.

DISCLAIMER

The manufacturer accepts no liability for any spoilage to the content of the refrigerator, not even when the device is within the warranty period. Similarly, the manufacturer accepts no liability for personal injury due to incorrectly stored goods, which are for personal consumption or resale.

FEATURES

PART II DIAGRAM & DESCRIPTION OF REFRIGERATOR

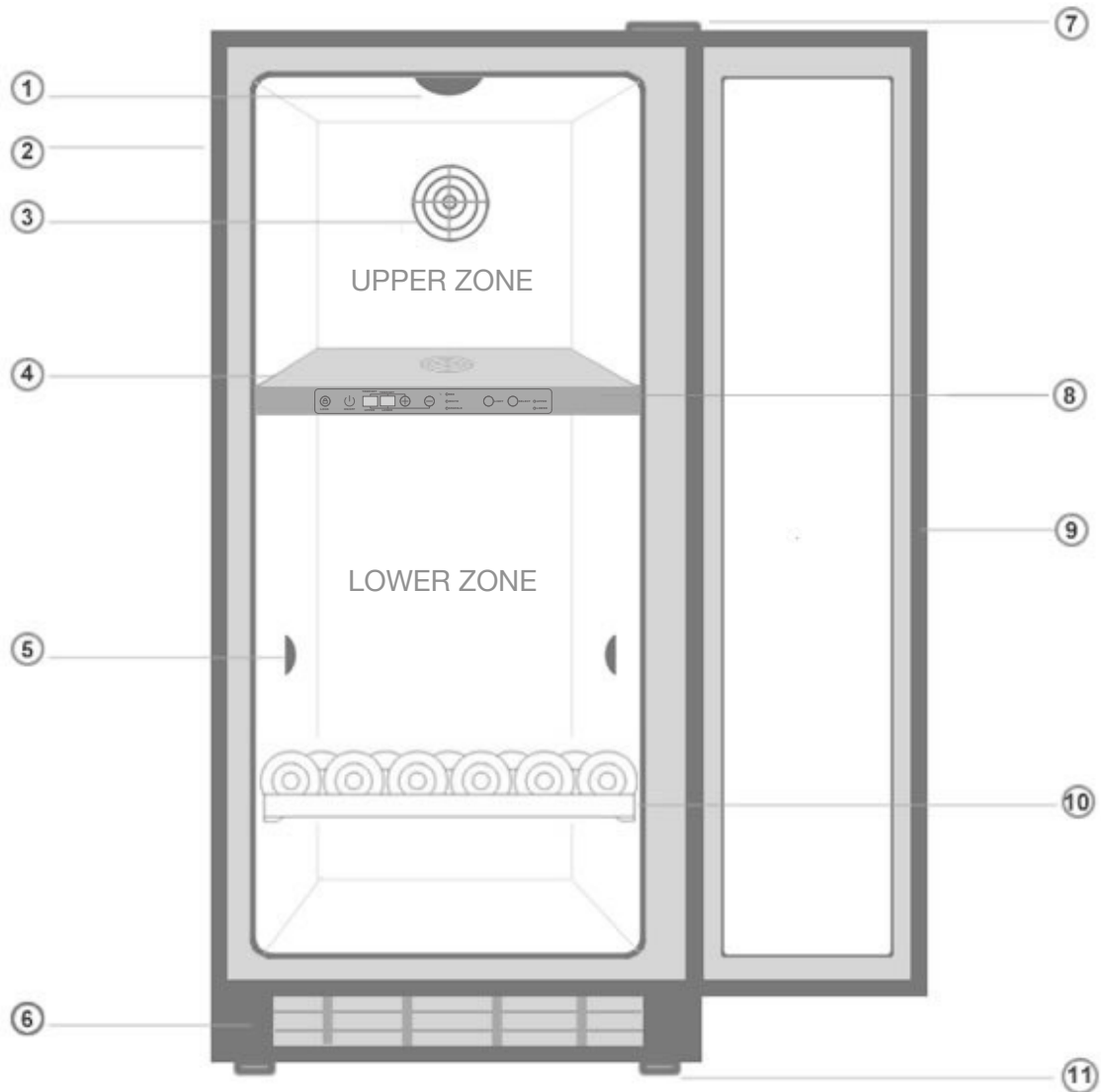

- 1 Interior Top LED Light
- 2 Housing
- 3 Ventilation DC Fan
- 4 PCB Control Board

- 5 Interior Side LED Light
- 6 Front grill
- 7 Door hinge
- 8 Display and Control Panel

- 9 Glass Door
- 10 Sliding shelf
- 11 Adjustable stand feet

YOUR WINE COOLER ALSO INCLUDES THE FOLLOWING:

- Instruction manual
- Two keys
- Top and bottom hinges , also screws for changing the door hinge

COMPRESSOR WINE COOLERS

INSTALLATION

PART III INSTALLATION INSTRUCTIONS

CUTOUT DIMENSION ILLUSTRATED

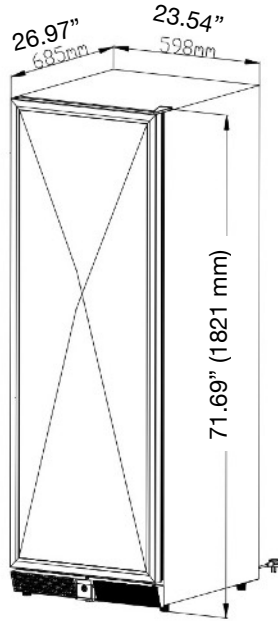

KBU-170 SERIES

23.54"W x 26.97"D x 71.69"H
 (598W x 685D x 1821H mm)
 Included stand height 0.98"(25mm)

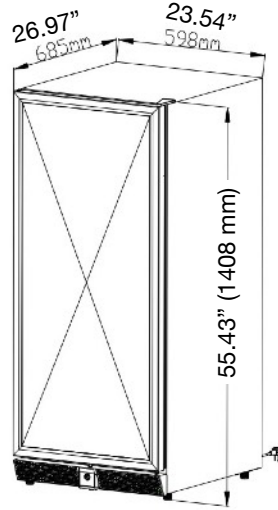

KBU-100 SERIES

23.54"W x 26.97"D x 55.43"H
 (598W x 685D x 1408H mm)
 Included stand height 0.98"(25mm)

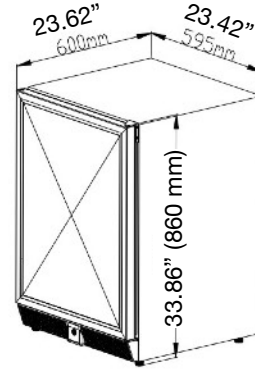

KBU-50 SERIES

23.42"W x 23.62"D x 33.86"H
 (595W x 600D x 860H mm)
 Included stand height 0.79" (20mm)

MODEL	WIDTH	DEPTH	HEIGHT	INCLUDED STAND HEIGHT	NOTE
KBU-50	23.42" 595mm	23.62" 600mm	33.86" 860mm	0.79" 20mm	These front-venting models can be built into cabinetry. Should it be built into cabinetry, there should be an additional 0.5" on either side, behind and on top of the unit. These extra spaces enable units to be placed in the position efficiently, accommodate the door when opened, and without the power cords being damaged.
KBU-100	23.54" 598mm	26.97" 685mm	55.43" 1408mm	0.98" 25mm	
KBU-170	23.54" 598mm	26.97" 685mm	71.69" 1821mm	0.98" 25mm	

INSTALLATION

PART III INSTALLATION INSTRUCTIONS

INSTALLING YOUR WINE COOLER

1. Move the unit into its final position. (CAUTION: for safety purpose, for the KBU100 and KBU170 models, it is necessary to anchor the appliances to the wall, please refer to the instruction on the next page.)
2. If the unit is not tilting back, minor adjustments can be made to the leveling legs.
3. Compare the alignment of the appliance to the surrounding cupboard. The top of the appliance should be level side to side (see diagram below).

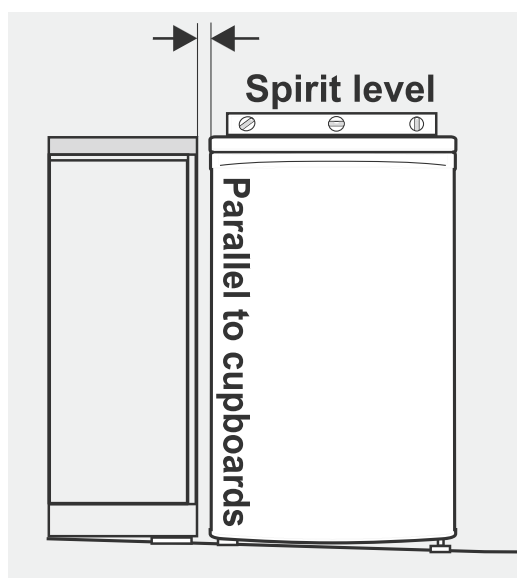

4. If the unit now rocks from one corner to the opposite rear corner, this means that the floor is uneven. You may need to put some packing under the ridge to the rear of the appliance. You could use thin pieces of a solid material such as a thin board, vinyl floor tiles or laminate.
5. You may now need to fine tune the installation by repeating steps 2, 3 and 4.
6. Wipe off any dust that has accumulated during shipping and clean following the directions in Part VI (Care & Maintenance)
7. Plug the appliance into the power point. Don't use a double adaptor or extension cord.
8. It is recommended that you allow the unit to rest an hour or two before you put any wine bottles in it. This will confirm that it is operating correctly and make the conditions appropriate for wine storage.

Congratulations! You have successfully installed your wine cooler.

DOOR LOCK

This unit comes with an optional key lock. The keys are located inside the plastic bag that contains the user manual. To lock the door, simply insert the key into the lock and turn clockwise making sure the metal pin is engaged completely. Then remove the key and place it in a secure place for safekeeping. To unlock the door, insert the key into the lock and turn counterclockwise.

INSTALLATION

Instructions to Anchor The Appliance to The Wall

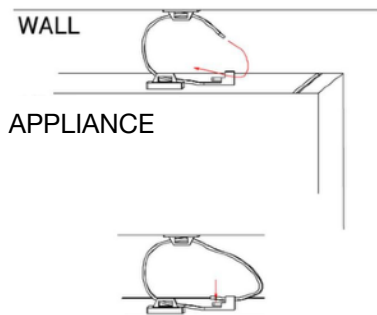
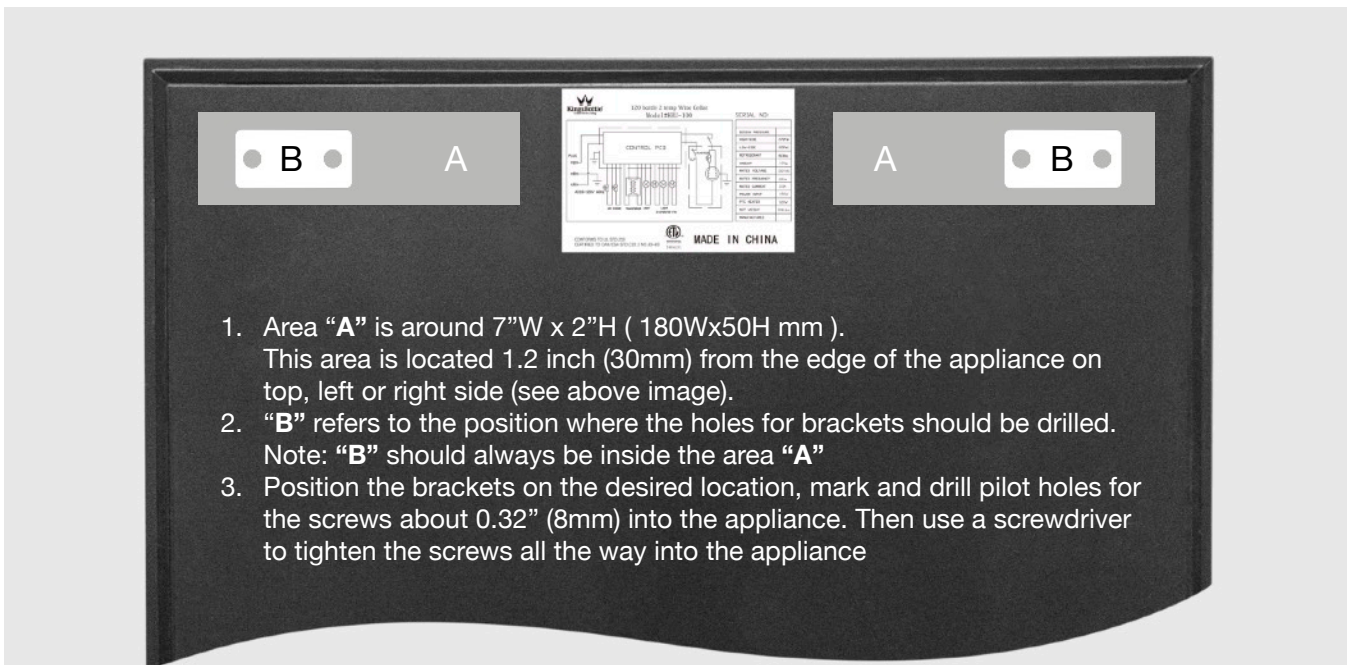
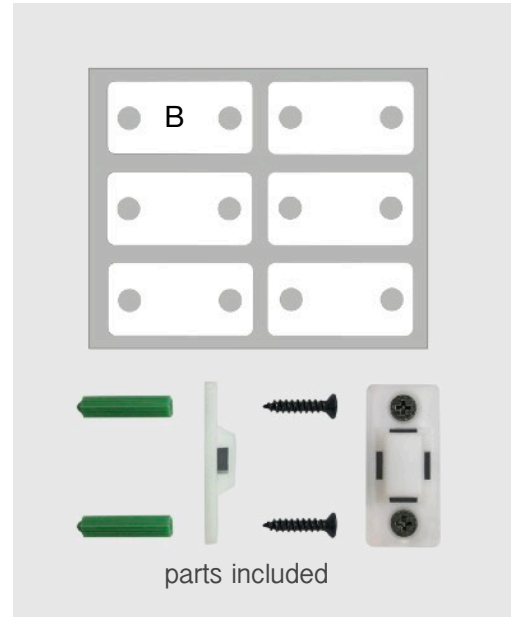

Position the appliance in the desired location. Locate wall studs behind the appliance and mark the location where the bracket lines up with a stud on the back of the appliance. Move the appliance away from the wall and position bracket on the mark. Mark and drill pilot holes into the center of the stud with a 3/32" drill bit. Attach a bracket to the stud with the long screws provided.

Move the appliance into its final position, taking care to line up the wall bracket close enough to the bracket on the back of the appliance to strap them together. Thread a strap through the brackets as shown in the illustration. Tighten the straps until snug. Do not over tighten.

CAUTION: These instructions are not intended to be a substitute for proper supervision. The manufacturer assumes no liability for improper installation or excessive loads placed on screws, brackets, or straps.

Straps should be periodically adjusted, tested and replaced.

STORAGE

PART IV

LAYOUT AND STORAGE

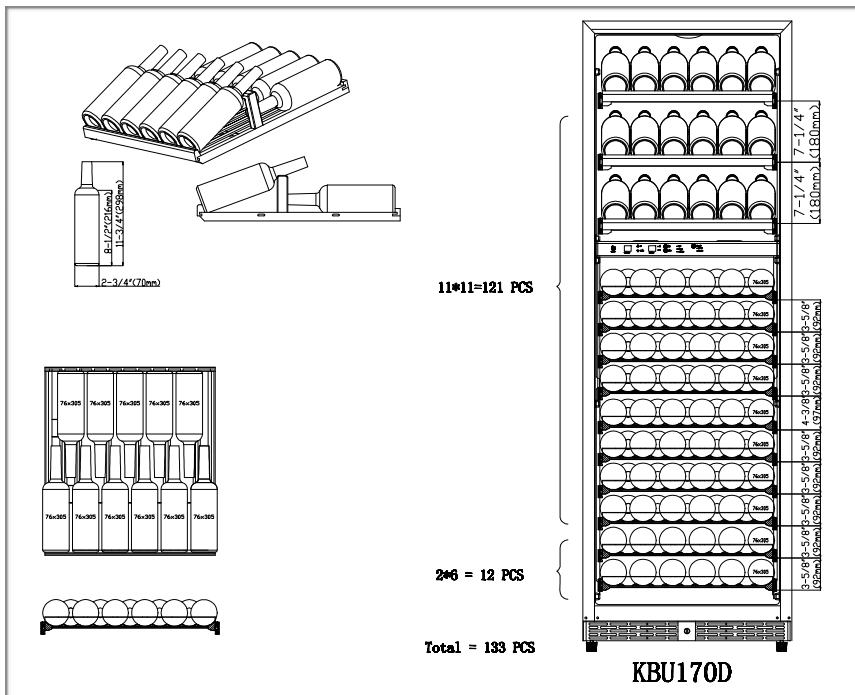
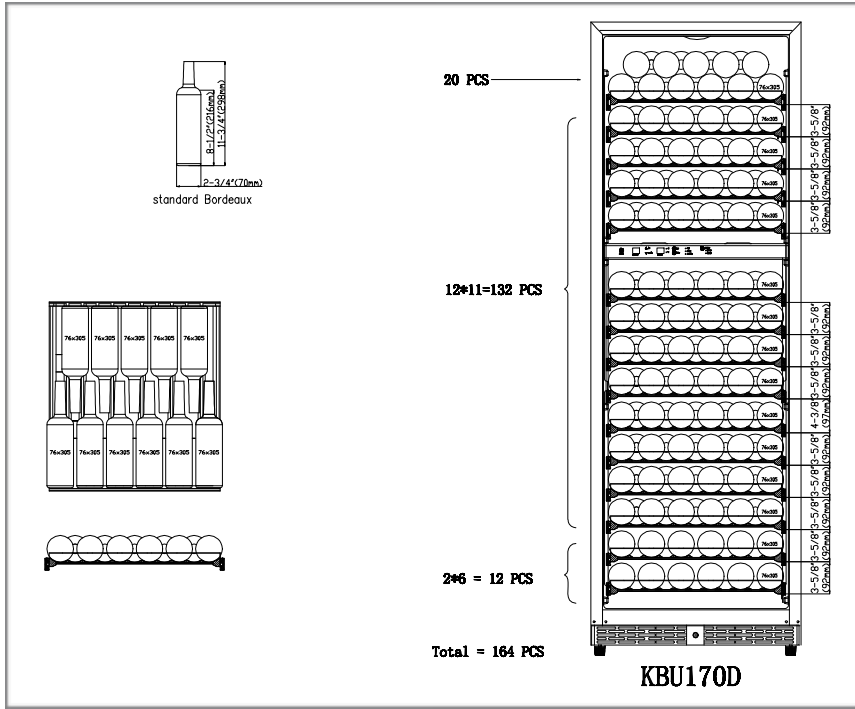

display shelves options

(for KBU170DX Models)

As an additional option, you might like the idea of having some display shelves to show your bottle label. You could refer to the instruction on how to remove the 2nd, 4th shelves in the upper zone (use the screws to fill the holes on the wall after the shelves are removed), and then change the 1st, 3rd, 5th shelves to display shelves.

Note:

This changes will reduce the total storage capacity.

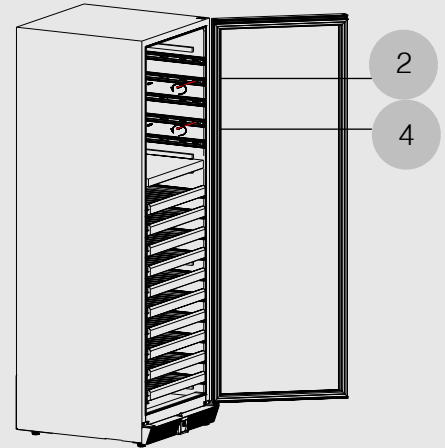

remove the 2nd, 4th shelves

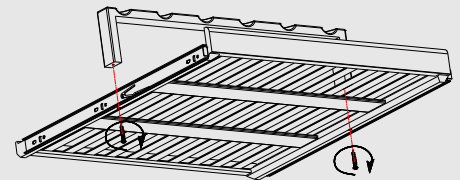

change the 1st, 3rd, 5th standard shelves to display shelves

PART IV LAYOUT AND STORAGE

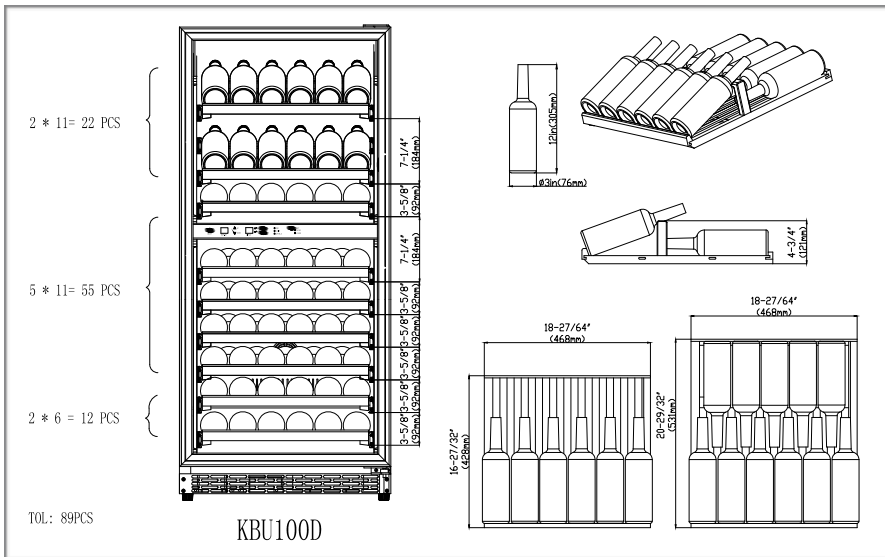
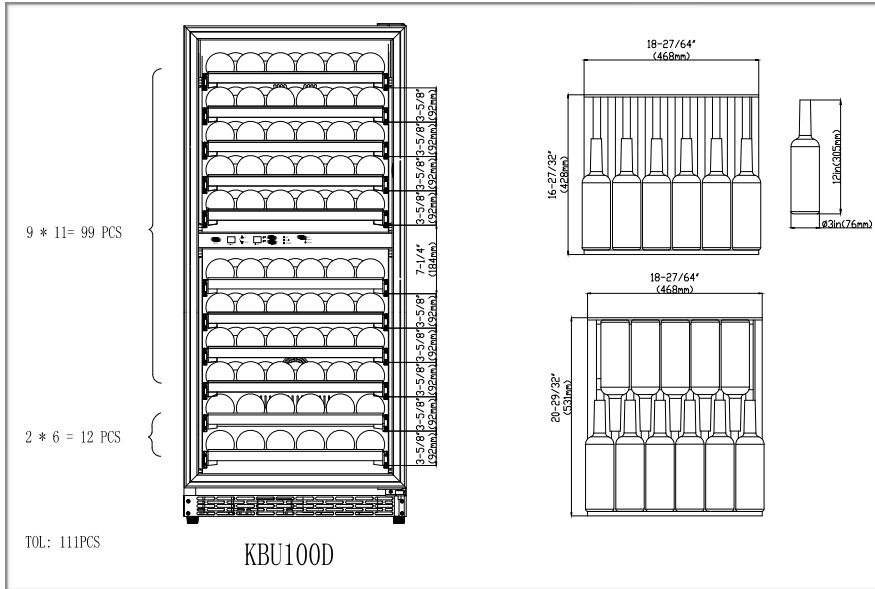

display shelves options

(for KBU100DX Models)

As an additional option, you might like the idea of having some display shelves to show your bottle label. You could refer to the instruction on how to remove the 1st, 3rd shelves in the upper zone (use the screws to fill the holes on the wall after the shelves are removed), and then change the 2nd, 4th shelves to display shelves.

Note:

This changes will reduce the total storage capacity.



remove the 1st, 3rd shelves

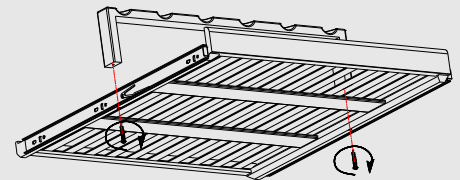

change the 2nd, 4th standard shelves to display shelves

STORAGE

PART IV

LAYOUT AND STORAGE

YOUR CABINET WAS DESIGNED TO STORE A MAXIMUM NUMBER OF BOTTLES SECURELY. WE RECOMMEND THAT YOU OBSERVE THE TIPS BELOW TO OPTIMIZE LOADING.

1. Disperse your bottles evenly so as not to concentrate the weight in any one area. Also, be careful that your bottles do not touch either the back of the cabinet or the step at the bottom.
2. Also, make sure that bottles are not all grouped together either at the top or bottom of the cabinet.
3. A cooler that is full and has a nice allowance for air movement will work more efficiently.
4. Never try to adjust shelf with bottles still on it.

TO REMOVE A ROLLING SHELF:

1. Remove all bottles
2. Pull the shelf out as far as possible
3. Push the LEFT side lever downward but the RIGHT side lever upward (as illustrated below)
4. Remove the shelf

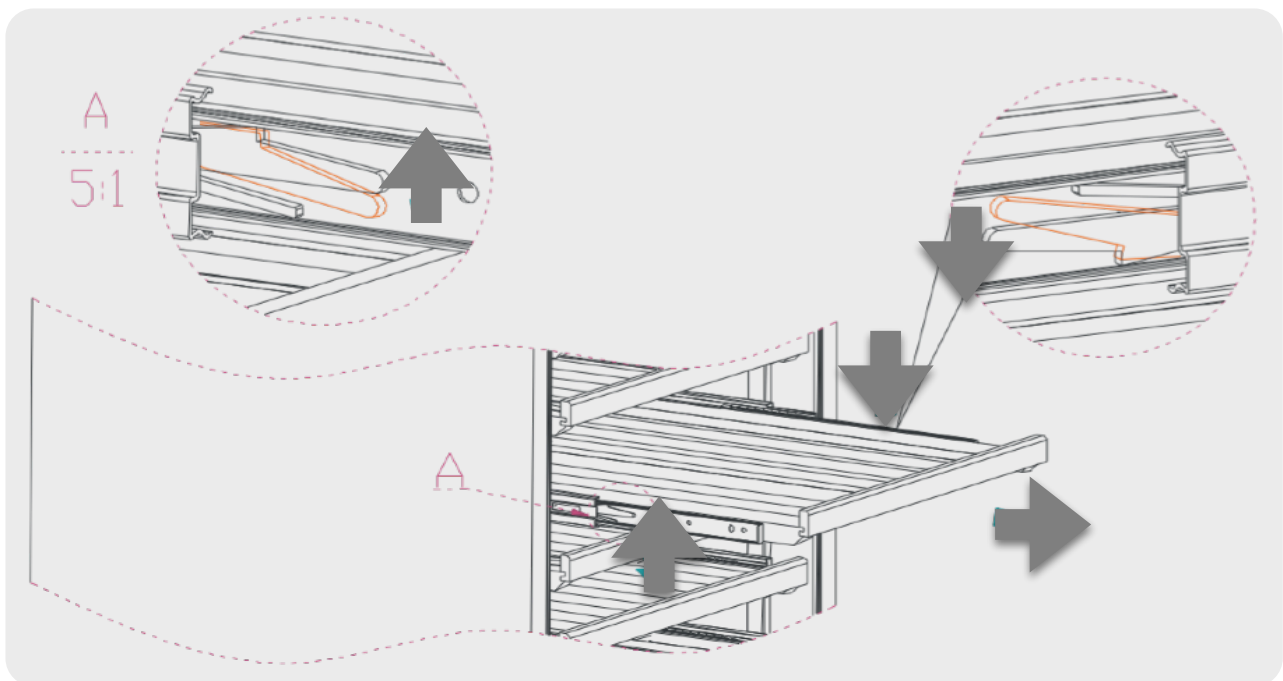

PLEASE NOTE

Before modifying your cabinet's original configuration in any way, be sure to ask your dealer for advice.

PART V OPERATING YOUR REFRIGERATOR

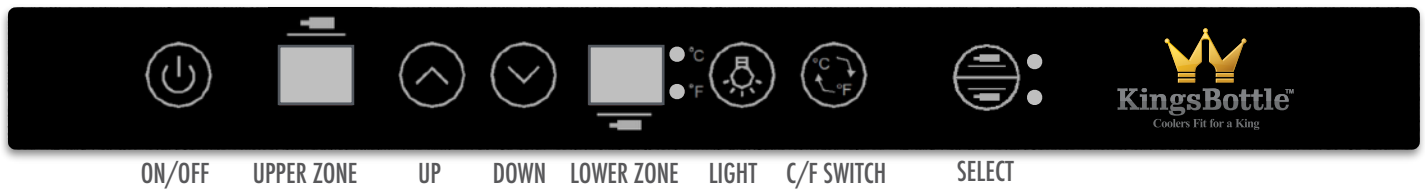

Each wine cooler includes an operating panel on the front of the unit. This operating panel includes several features to operate and control the temperature of both the upper and lower zones of the wine cooler.

The operating panel includes the following features:

ON/OFF: Turns the wine cooler power on or off.

TEMP. SET UPPER ZONE: Adjusts and displays, via LED, the desired temperature and the actual temperature of the upper zone.

TEMP. SET LOWER ZONE: Adjusts and displays, via LED, the desired temperature and the actual temperature of the lower zone.

LIGHT: Turns the interior wine cooler light on or off.

SELECT: Allows the user to select to control the UPPER or LOWER zone.

C/F SWITCH: Switch between °C and °F

SETTING THE TEMPERATURE CONTROL

IMPORTANT: IN ORDER FOR THIS UNIT TO FUNCTION AT OPTIMUM LEVEL, THE LOWER COMPARTMENT SHOULD BE SET AT LEAST 4-DEGREES (F) HIGHER THAN THE UPPER COMPARTMENT.

1. Make sure the power cord is connected to a properly grounded outlet.
2. Turn Power ON.
3. Press the "SELECT" button to choose the "UPPER" or "LOWER" zone. Each zone is independently controlled.
 - Upper Zone: The temperature setting can be adjusted between 41°F to 60°F
 - Lower Zone: The temperature setting can be adjusted between 45°F to 64°F
4. Set the temperature of the Upper Zone or Lower Zone as you desire by pushing the UP or DOWN button. When you push the two buttons for the first time, the LED readout will show the original temperature set at the previous time.
5. Once you have set the desired temperature, wait for 5 seconds. The temperature shown in both Upper and Lower zone display panels will automatically switch to show the actual temperature inside the unit. The actual temperature will always be shown until the next time you press the UP or DOWN button to change the temperature settings.

NOTE: The desired temperatures may fluctuate depending on whether the interior light is ON or OFF, the ambient temperature, the location of the unit and the orientation of the bottles. The display is just a guide, be guided by how cold your drinks are at consumption. Remember units go into defrost mode, and this will show a higher display, it's only for short periods and doesn't have time to affect drink temperature. In general, once the unit has settled, it will keep products within 5°F (2°C) of the set temp easily in temperatures up to and beyond 100°F (38°C).

TEMPERATURE SETTINGS FOR WINE SERVICE

Different varietals of wine require different temperature settings. The recommended temperature ranges for long term storage of different varietals of wine are listed below.

- Red Wines: 52-64°F
- White Wines: 44-51°F
- Sparkle Wines: 41-43°F

CAUTION

1. In the event of a power interruption, all previous temperature settings will be automatically saved and each compartment will return to the previous temperature setting.
2. If the unit is unplugged, loses power, or is turned off, there will be a 6 minute delay for the compressor to restart after the unit is powered ON.
3. When you use the wine cooler for the first time or restart the wine cooler after having been shut off for a long time, there will be a few degrees variance between the temperature you select and the one indicated on the LED readout for the first few hours of operation. After a few hours of operation, the temperature will normalize to the displayed temperature.

OPERATION

ERROR CODE AND ALARM

Code	Description	Solution
E1	When the temp. In the UPPER zone is 4°F (2°C) higher than the LOWER zone, E1 displays on the panel.	With the temp. changes, and temp. in the UPPER zone is lower than the LOWER zone, E1 will disappear automatically. So, just wait for about one hour and check again.
F1	When the evaporator temperature is lower than 0°F (-18°C) F1 displays on the panel F1 meaning the cooler is at defrosting mode. During DEFROSTING period, evaporator fan is operating, but the compressor stopped. After evaporator temp. is higher than 39°F (4°C), F1 will disappear	It's normal; nothing needs to be done. Wait for 3 hours and check again. Or, turn OFF the power, open the door and wait for 3 hours, then check again.
F2	If the compressor keeps operating continuously for over 8 hours, the cooler will automatically enter DEFROSTING mode and F2 displays on the panel F2 meaning the cooler is at defrosting mode. During DEFROSTING period, evaporator fan is operating, but the compressor stopped. F2 will disappear after 20 minutes.	It's normal; nothing needs to be done. Wait for 30 minutes and check again.
C1	C1 displaying on the panel means the sensor in the UPPER zone is open-circuit. Compressor stop operating and no cooling	Need an engineer to check Socket/plug with UP mark in PCB is badly connected. The sensor is damaged, need to replace it Repair or replace the PCB
C2	C2 displaying on the panel means the sensor in the LOWER zone is open-circuit. Compressor stop operating and no cooling * This does not apply to SINGLE zone models	Need an engineer to check Socket/plug with DOWN mark in PCB is badly connected The sensor is damaged, need to replace it Repair or replace the PCB
C3	C3 displaying on the panel means evaporator sensor is open-circuit. Compressor stops operating and no cooling.	Need an engineer to check Socket/plug with PTC mark in PCB is badly connected The sensor is damaged, need to replace it Repair or replace the PCB
U1	U1 displaying on the panel means a sensor which is in the UPPER zone is short-circuited. Compressor stops operating and no cooling.	Need an engineer to check The sensor is damaged, need to replace the sensor which is connected to UP socket/plugin PCB Repair or replace the PCB
U2	U2 displaying on the panel means a sensor which is in the LOWER zone is short-circuited. Compressor stop operating and no cooling * This does not apply to SINGLE zone models	Need an engineer to check The sensor is damaged, need to replace the sensor which is connected to DOWN socket/plugin PCB Repair or replace the PCB
U3	U3 displaying on the panel means evaporator sensor is short-circuited. Compressor stops operating and no cooling.	Need an engineer to check The sensor is damaged, need to replace the sensor which is connected to PTC socket/plugin PCB Repair or replace the PCB
No Code	After the temp. is lower than 32°F (0°C) or higher than 69°F (20°C), the buzzer will alarm and remind the user needs to pay attention.	Normal, nothing needs to be done.

PART VI CARE AND MAINTENANCE

CLEANING YOUR WINE COOLER



BEFORE CLEANING: Turn off the power, unplug the appliance, and remove all items including all the shelves.

- Wash the inside surfaces with warm water and baking soda solution. The solution should be about 2 tablespoons of baking soda with a quart of water.
- Wash the shelves with a mild detergent solution.
- Wring excess water out of the sponge or cloth when cleaning area of the controls, or any electrical parts.
- Wash the outside cabinet with warm water and a mild liquid detergent. Rinse well and wipe dry with a clean, soft cloth.
- After installation, we recommend that owners apply a thin layer of Olive Oil with a clean rag, to all exposed Stainless Steel areas. This should then be polished in and buffed off with another clean rag to a non-oily finish. This process will aid protection against dirt and other corrosive contaminants, by providing a temporary food-safe shield. The Olive Oil layer also makes later polishing and removal of fingerprints easier. This process should be repeated frequently every 3-4 months. ALL stainless steel can rust; it is a myth that stainless steel doesn't rust.

POWER FAILURE

Most power failures are corrected within a few hours and should not affect the temperature of your appliance if you minimize the number of times the door is opened. If the power is going to be off for a longer period of time, you need to take the proper steps to protect your contents.

VACATION TIME

Short vacations: You may leave the wine cooler operating during vacations of less than three weeks.

Long vacations: If the appliance will not be used for several months, remove all items and turn off the appliance. Clean and dry the interior thoroughly. To prevent mold growth, leave the door open slightly, blocking it open if necessary.

MOVING YOUR WINE COOLER

1. Remove all items.
2. Securely tape down all loose items (shelves) inside your appliance.
3. Turn the adjustable leg up to the base to avoid damage.
4. Tape the door shut.
5. Be sure the appliance stays secure in the upright position during transportation. Also, protect the outside of the appliance with a blanket or similar item.

ENERGY SAVING TIPS

- The wine cooler should be located in the coolest area of the room, away from heat-producing appliances, and away from direct sunlight. Ventilation at the rear also helps a lot with energy usage, to create a positive air flow where possible, although with this range they are designed to be fully built in.
- When you are not using cooler during weekdays etc. it is recommended to set the temp at a higher level, so set at 64°F (18°C) during periods of non-usage, this will not only mean less run time, it will also keep drinks at a temp that won't get them spoiled. It saves energy also which these days are a growing concern for most households.
- Keep the cooler stocked; an empty cooler will run longer, believe it or not.

TROUBLESHOOTING GUIDE

PART VII TROUBLESHOOTING GUIDE

PROBLEM	POSSIBLE CAUSE	Solution
Refrigerator does not operate	Not plugged in The appliance is turned OFF at the control panel The circuit breaker has tripped, or a fuse has blown out	Press ON/OFF Check and make sure the power plug is well connected Ask an engineer for help
Refrigerator is not cold enough; can not cool down to the preset temp.	The compressor does not start	ask an engineer for help / check the connection of the compressor
	Compressor self-protected and has stopped operating	The ambient temperature is too high (over 100°F) The air venting is not smooth, check that the air duct is not blocked Fan operates slowly or is faulty and has stopped functioning. The door is not closed completely, or the door opened too long The compressor, or its components are faulty.
	Fans stop working or operate at low speed	Ask an engineer for help. Power the refrigerator ON and OFF. Check the fan and whether the voltage is normal. If the voltage is normal, then the fan could be damaged.
	Evaporator ices up	Turn OFF the refrigerator for one hour and open the door. The ice on the evaporator will melt. Check the door seal for any air gaps.
	The door is not closed properly	Check the door lock, shelves, or other objects; make sure the door is well closed. Check the rubber seal for any air gaps. Check the door hinges; make sure they are not loose.
	Condenser is dusty	Wash and clean the condenser
	Cooling system faulty (Gas leakage or blockage)	Ask an engineer for help
Compressor starts and stops frequently	The door gasket does not seal properly.	Use low heat on a hair dryer to make the door seal take shape.
	The sensor connection is wrong.	Read the wiring diagram to make the correct connection of the sensor.
	The sensor is faulty.	Replace with a new sensor
	The door is opened too often.	Reduce the times/frequency of door openings.
The light does not work.	Not plugged in, or the light button is "OFF." The light itself is faulty.	Check and make sure the light button is ON, or ask an engineer for help.
The Refrigerator seems to make too much noise.	The stand feet is not leveling; vibrations lead to noise	Adjust the stand feet and ensure they are leveled.
	Copper pipe hits other objects and makes noise	Gently adjust the position of the pipe.
	When the compressor shuts down or starts, it is normal for noise due to vibrations to be generated by the internal moving parts due to inertia.	Take no action
	A liquid plumbing noise may come from the flow of the refrigerators gases, which is normal. As each cycle ends, you may hear gurgling sounds.	Take no action
The door will not close properly.	The door is blocked by the door lock, shelves, or other objects.	Remove the barrier
	Door sealing rubber is deformed	Repair or replace the rubber seal
	Door hinges are loose.	Adjust and fasten the hinges.
Ice up	Outlet/suction outlet blockage	Remove the barrier
	Fans stop working or operate at low speed.	Ask an engineer for help. Power the refrigerator ON and OFF. Check the fan and the voltage. If the voltage is normal, the fan may be damaged.
	The door gasket does not seal properly, or door is opened too often	Use low heat on a hair dryer to make the door seal take shape.
	Gas leakage or cooling system blockage	Ask an engineer for help
External cabinet seems too hot	Ambient temperature is too high, or direct sunshine	Operating conditions need to be improved
	Front grill outlet/suction outlet blockage	Remove the barrier
	Fans stop working or low speed operating	Ask an engineer for help, power on the refrigerator, check the fan whether the voltage is normal or not. If the voltage is normal, the fan could be damaged.
Water drop on glass door	Ambient humidity is high	Use a soft cloth to clean the water
	The door is opened too often	Reduce the times/frequency of door opening.
	The door gasket does not seal properly	Use low heat on a hair dryer to make the door seal take shape.

TECHNICAL DATA

PART X TECHNICAL DATA

MODEL NO.	KBU170DX	KBU100DX	KBU50DX
VOLUME	14.30 CF (405 Liter)	10.88 CF (308 Liter)	5.37 CF (152 Liter)
TYPE OF COOLING	compressor with air-circulated fan cooling	compressor with air-circulated fan cooling	compressor with air-circulated fan cooling
CLIMATE TYPE	N	N	N
ELECTRICITY PROTECTION GRADE	I	I	I
NOMINAL VOLTAGE/FREQUENCY	110-115V/50-60HZ	110-115V/50-60HZ	110-115V/50-60HZ
RATED CURRENT	1.1 A	1.1 A	0.9 A
RATED POWER(W)	80W	80W	72W
REFRIGERANT	R600a	R600a	R600a
AMBIENT TEMPERATURE	32 - 100 °F (0 -38°C)	32 - 100 °F (0 -38°C)	32 - 100 °F (0 -38°C)
TEMPERATURE RANGE	Upper Zone: 41-60 °F (5 - 15°C); Lower Zone: 45-64 °F (7 - 18°C)	Upper Zone: 41-60 °F (5 - 15°C); Lower Zone: 45-64 °F (7 - 18°C)	Upper Zone: 41-60 °F (5 - 15°C); Lower Zone: 45-64 °F (7 - 18°C)
NET WEIGHT	286.60 lbs (130 KGS)	198.41 lbs (90 KGS)	112.43 lbs (51 KGS)
GROSS WEIGHT (INC. PALLET)	310 lbs (141 KGS)	239 lbs (108 KGS)	159 lbs (72 KGS)
DIMENSION	23.54"W x 26.97"D x 71.69"H (598W x 685D x 1821H mm) Included stand height 0.98" (25mm)	23.54"W x 26.97"D x 55.43"H (598W x 685D x 1408H mm) Included stand height 0.98" (25mm)	23.42"W x 23.62"D x 33.86"H; (595W x 600D x 860H mm) Included stand height 0.79" (20mm)

PART IX WARRANTY INFORMATION

Registering online is quick and easy!

<https://kingsbottle.com/apps/product-registration>

Please speak to your retailer before calling us if you did not purchase your refrigerator directly from KingsBottle.

WHO IS COVERED: This warranty is extended only to the original end-user purchaser or the person receiving the product as a gift, and shall not be extended to any other person or transferee.

LIMITED WARRANTY – If your refrigerator is not operating properly, KingsBottle reserves the right to repair or replace the refrigerator. KingsBottle may request the consumer to contact a local refrigeration company to service the refrigerator. All cost for labor and materials is covered for 2-year from the date of receipt. If KingsBottle deems the unit not repairable, KingsBottle will use the value of your original order toward a replacement (Any replacement unit will follow the warranty terms of the initial purchase). For customer service, please e-mail us via service@kingsbottle.com.

THE LIMITED WARRANTY DOES NOT COVER: Damage due to such things as an accident, misuse, abuse, mishandling, neglect, unauthorized repair or any other cause beyond the control of the seller whether similar or dissimilar to the foregoing. Purchaser understands and acknowledges that the goods sold here are WINE & BEVERAGE COOLERS, which house beer and other wines. Purchaser assumes all the risk of using these units, including the risk of spoilage, humidity variations, temperature variations, leaks, fires, water damage, mold, mildew, dryness and similar perils that may occur.

SPECIAL NOTE: Warranty is only honored for the unit which is used in the countries where the unit was initially purchased. And, if your product was purchased at any 3rd party retailer and not directly from KingsBottle, we do not offer an extended warranty policy. You MUST contact the retailer of purchase directly. In the event your retailer does not offer an extended warranty plan, we recommend you contact a third party warranty provider. However, regardless of point of purchase, all KingsBottle coolers are backed by a TWO YEAR manufacturer's warranty from date of sale.

COMPRESSOR WINE REFRIGERATOR

