

DIMENSION : Metric Inch

REV. DETAIL OF REVISION DATE APPROVED

SPECIFICATION

1. Working Pressure : 689 bar(10000psig)
2. Temperature Rating : -53 to 232°C(-65 to 45°F) with PTFE packing
3. Orifice : 3.2mm(0.126 in.)
4. Cv : 0.21

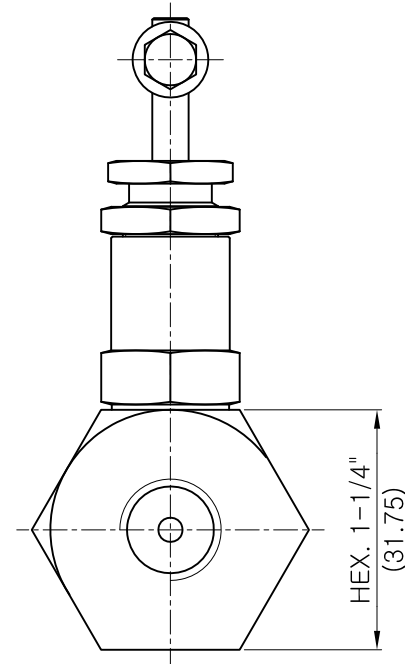
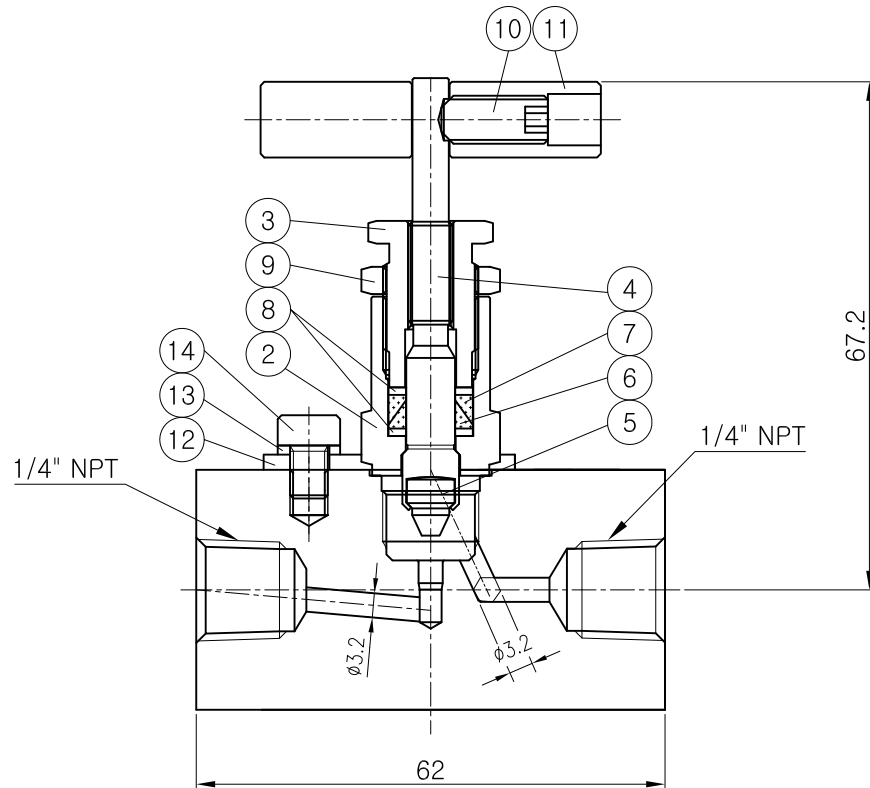

Pressure-Temperature Ratings

Temperature °C	Working Pressure bar
-53 to -28	689
-28 to 37	689
93	640
148	578
176	554
204	530
230	512

7	Upper Packing	1	PTFE
6	Lower Packing	1	PTFE
5	Stem Disc	1	ASTM A564 TYPE 630
4	Stem	1	ASTM A276 TYPE 316
3	Packing Bolt	1	ASTM A276 TYPE316
2	Bonnet	1	ASTM A276 TYPE316
1	Body	1	ASTM A276 TYPE316
NO.	DESCRIPTION	Q'TY	MATERIAL

14	Wrench Bolt	1	Stainless Steel
13	Spring Washer	1	Stainless Steel
12	Locking Plate	1	Stainless Steel
11	Handle	1	ASTM A276 TYPE 316
10	Set Screw	1	Stainless Steel
9	Lock Nut	1	ASTM A276 TYPE 316
8	Packing Gland	1	ASTM A276 TYPE 316
NO.	DESCRIPTION	Q'TY	MATERIAL

NO.	DESCRIPTION	Q'TY	MATERIAL	REMARK
DATE	2014.01.29	SCALE	1 : 1	
DRAWN	CHK'D	APP'D	CUSTOMER	
TITLE			VNH10 Series Bonnet Needle Valve 1/4 In. FNPT	
HSME corporation			DWG NO.	VNH10A-F4N-SS 0

DIMENSION : Metric Inch

REV. DETAIL OF REVISION DATE APPROVED

SPECIFICATION

1. Working Pressure : 689 bar(10000psig)
2. Temperature Rating : -53 to 232°C(-65 to 45°F) with PTFE packing
3. Orifice : 3.2mm(0.126 in.)
4. Cv : 0.21

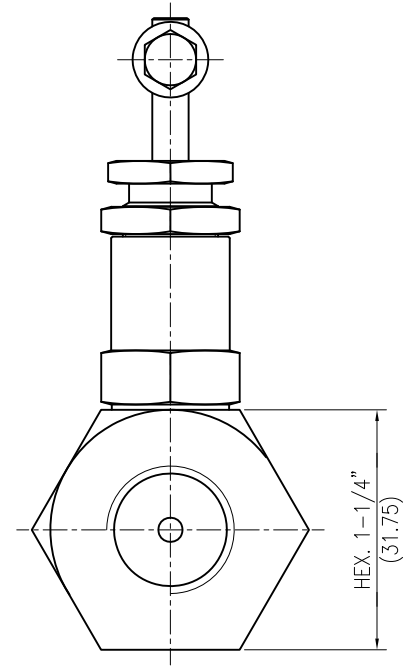
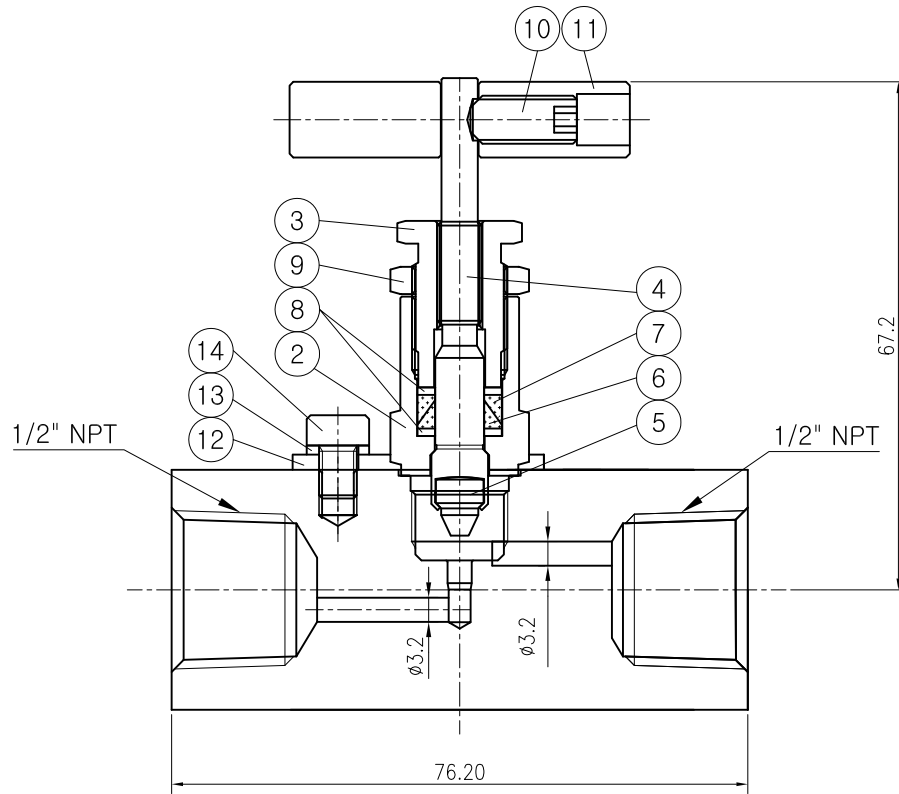

Pressure-Temperature Ratings

Temperature °C	Working Pressure bar
-53 to -28	689
-28 to 37	689
93	640
148	578
176	554
204	530
230	512

7	Upper Packing	1	PTFE
6	Lower Packing	1	PTFE
5	Stem Disc	1	ASTM A564 TYPE 630
4	Stem	1	ASTM A276 TYPE 316
3	Packing Bolt	1	ASTM A276 TYPE316
2	Bonnet	1	ASTM A276 TYPE316
1	Body	1	ASTM A276 TYPE316
NO.	DESCRIPTION	Q'TY	MATERIAL

14	Wrench Bolt	1	Stainless Steel
13	Spring Washer	1	Stainless Steel
12	Locking Plate	1	Stainless Steel
11	Handle	1	ASTM A276 TYPE 316
10	Set Screw	1	Stainless Steel
9	Lock Nut	1	ASTM A276 TYPE 316
8	Packing Gland	1	ASTM A276 TYPE 316
NO.	DESCRIPTION	Q'TY	MATERIAL

NO.	DESCRIPTION	Q'TY	MATERIAL	REMARK
DATE	2014.01.29	SCALE	1 : 1	
DRAWN	CHK'D	APP'D	CUSTOMER	
TITLE			VNH10 Series Bonnet Needle Valve 1/2 In. FNPT	
HSME corporation			DWG NO.	VNH10A-F8N-SS 0