

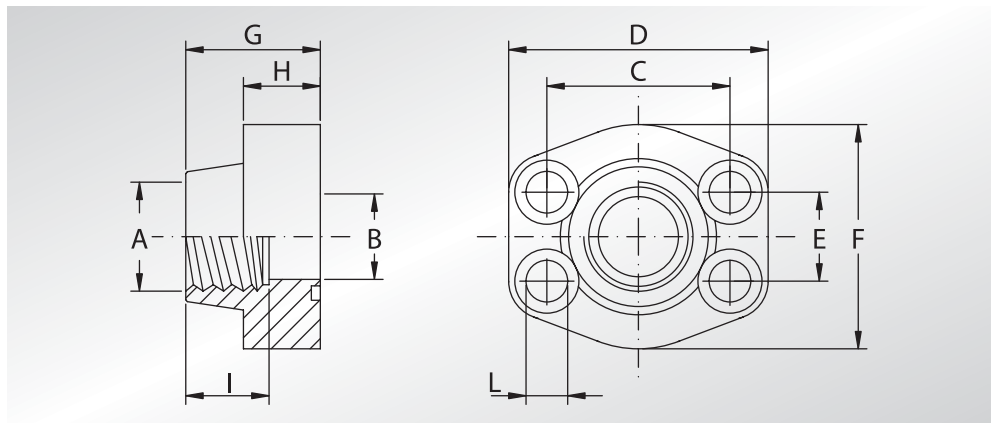

FLANGE FILETTATE NPT

NPT THREADED FLANGES



Pressione max di esercizio raccomandata Kg/cm ²	Grandezza	Tipo	Dimensioni										Viti		Or tipo	Peso Kg
Maximum recommended working pressure Kg/cm ²	Size	Type	Dimensions										Screws		Or type	Weight Kg
			A	B	C	D	E	F	G	H	I	L	Metric	Unc		

SERIE 3000

345	1/2"	AFS080N	1/2" NPT	13	38,10	57	17,48	46	36	16	19	9	M8x30	5/16x1"1/4	4075	0,25
345	1/2"	AFS080N038	3/8" NPT	13	38,10	57	17,48	46	36	16	19	9	M8x30	5/16x1"1/4	4075	0,27
345	3/4"	AFS100N	3/4" NPT	19	47,63	65	22,23	50	36	18	19	11	M10x35	3/8x1"1/2	4100	0,37
345	3/4"	AFS100N012	1/2" NPT	13	47,63	65	22,23	50	36	18	19	11	M10x35	3/8x1"1/2	4100	0,40
345	1"	AFS102N	1" NPT	25	52,37	70	26,19	55	38	18	22	11	M10x35	3/8x1"1/2	4131	0,45
345	1"	AFS102N034	3/4" NPT	19	52,37	70	26,19	55	35	21	19	11	M10x40	3/8x1"1/2	4131	0,51
276	1"1/4	AFS104N	1"1/4 NPT	32	58,72	79	30,18	68	41	21	22	11,5	M10x40	7/16x1"3/4	4150	0,66
276	1"1/4	AFS104N100	1" NPT	25	58,72	81	30,18	65	42	25	24	11,5	M10x40	7/16x1"3/4	4150	0,80
207	1"1/2	AFS106N	1"1/2 NPT	38	69,85	93	35,71	78	45	25	24	13,5	M12x45	1/2x1"3/4	4187	1,05
207	1"1/2	AFS106N114	1"1/4 NPT	32	69,85	95	35,71	78	45	27	24	13,5	M12x45	1/2x1"3/4	4187	1,17
207	2"	AFS108N	2" NPT	51	77,77	102	42,88	90	45	25	30	13,5	M12x45	1/2x1"3/4	4225	1,17
207	2"	AFS108N112	1"1/2 NPT	38	77,77	102	42,88	90	45	25	26	13,5	M12x45	1/2x1"3/4	4225	1,52
172	2"1/2	AFS110N	2"1/2 NPT	63	88,90	114	50,80	105	50	25	30	13,5	M12x45	1/2x1"3/4	4275	1,59
138	3"	AFS112N	3" NPT	73	106,38	134	61,93	124	50	27	34	17,5	M16x50	5/8x2"	4337	2,28
34	3"1/2	AFS114N	3"1/2 NPT	89	120,65	152	69,85	136	48	27	34	17,5	M16x50	5/8x2"	4387	2,42
34	4"	AFS116N	4" NPT	99	130,18	162	77,77	146	48	27	34	17,5	M16x50	5/8x2"	4437	2,78
34	5"	AFS118N (*)	5" NPT	120	152,40	184	92,08	180	50	28	30	17,5	M16x50	5/8x2"	4537	5,80

SERIE 6000

414	1/2"	AFS401N012	1/2" NPT	13	40,49	57	18,24	46	36	16	19	9	M8x30	5/16x1"1/4	4075	0,25
414	1/2"	AFS401N038	3/8" NPT	13	40,49	57	18,24	46	36	16	19	9	M8x30	5/16x1"1/4	4075	0,28
414	3/4"	AFS402N	3/4" NPT	19	50,80	71	23,80	55	35	21	22	11	M10x40	3/8x1"1/2	4100	0,51
414	3/4"	AFS402N012	1/2" NPT	13	50,80	71	23,80	55	35	21	22	11	M10x40	3/8x1"1/2	4100	0,56
414	1"	AFS403N	1" NPT	25	57,15	81	27,76	65	42	25	24	13	M12x45	7/16x1"3/4	4131	0,81
414	1"	AFS403N034	3/4" NPT	19	57,15	81	27,76	65	42	25	24	13	M12x45	7/16x1"3/4	4131	0,84
414	1"1/4	AFS404N	1"1/4 NPT	32	66,68	95	31,75	78	45	27	25	15 *	M14x45	1/2x1"3/4	4150	1,13
414	1"1/4	AFS404N100	1" NPT	25	66,68	95	31,75	78	45	27	25	15 *	M14x45	1/2x1"3/4	4150	1,26
414	1"1/2	AFS405N	1"1/2 NPT	38	79,38	112	36,50	94	50	30	28	17	M16x50	5/8x2"	4187	1,81
414	1"1/2	AFS405N114	1"1/4 NPT	32	79,38	112	36,50	94	50	30	28	17	M16x50	5/8x2"	4187	1,95
414	2"	AFS406N	2" NPT	51	96,82	134	44,45	114	65	37	30	21	M20x70	3/4x2"1/2	4225	3,31
414	2"	AFS406N112	1"1/2 NPT	38	96,82	134	44,45	114	65	37	30	21	M20x70	3/4x2"1/2	4225	3,8
414	2"1/2	AFS507N	2"1/2 NPT	63	123,80	180	58,70	152	80	45	32	26	M24x80	-	4275	6,75
414	3"	AFS508N	3" NPT	73	152,40	208	71,40	178	90	55	40	33	M30x100	-	4337	-

DESIGNAZIONE PER ORDINE DESIGNATION FOR ORDER	Materiale / Material	
	ST52.3	AISI 316L
Solo flangia Only flange	AFS...N	AFX...N
Flangia completa di viti metriche, grower e o-ring Flange complete of metric screws, grower type washers and o-ring	AFS...NM	AFX...NM
Flangia completa di viti unc, grower e o-ring Flange complete of unc screws, grower type washers and o-ring	AFS...NU	AFX...NU

NOTE / NOTES

* Per viti unc L=13,5
* For unc screws L=13,5

(●) Solo in ST52.3
(●) Only in ST52.3

set viti unc disponibili solo in acciaio al carbonio.
unc screws set available only in carbon steel.