

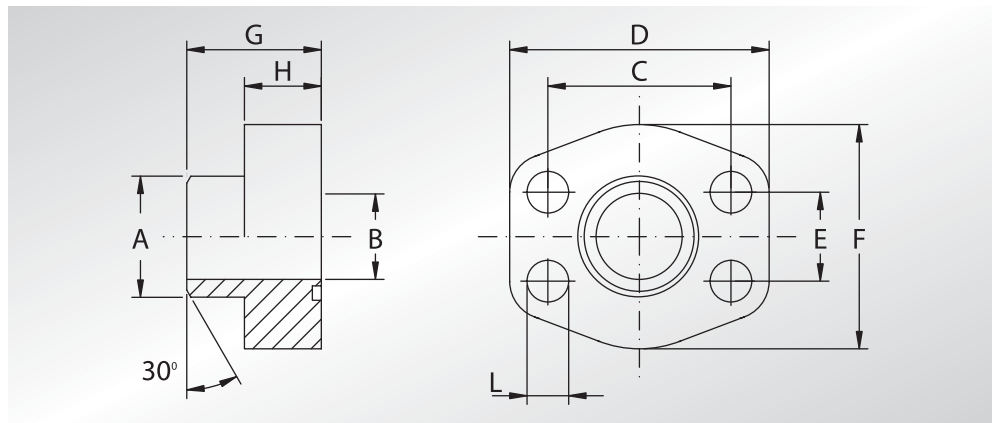

FLANGE A SALDARE DI TESTA SCH.80

WELD ON FLANGES SCH.80



Pressione max di esercizio raccomandata Kg/cm ²	Grandezza	Tipo	Dimensioni									Viti		Or tipo	Peso Kg
Maximum recommended working pressure Kg/cm ²	Size	Type	Dimensions									Screws		Or type	Weight Kg
			A	B	C	D	E	F	G	H	L	Metric	Unc		

SERIE 3000

345	1/2"	AFS080ST	21,5	13	38,10	57	17,48	46	36	16	9	M8x30	5/16x1"1/4	4075	0,24
345	1/2"	AFS080ST038	17,5	13	38,10	57	17,48	46	36	16	9	M8x30	5/16x1"1/4	4075	0,22
345	3/4"	AFS100ST	28,0	19	47,63	65	22,23	50	36	18	11	M10x35	3/8x1"1/2	4100	0,35
345	1"	AFS102ST	34,0	25	52,37	70	26,19	55	38	18	11	M10x35	3/8x1"1/2	4131	0,41
276	1"1/4	AFS104ST	42,8	32	58,72	79	30,18	68	41	21	11,5	M10x40	7/16x1"3/4	4150	0,64
207	1"1/2	AFS106ST	48,6	38	69,85	93	35,71	78	44	25	13,5	M12x45	1/2x1"3/4	4187	0,98
207	2"	AFS108ST	61,0	51	77,77	102	42,88	90	45	25	13,5	M12x45	1/2x1"3/4	4225	1,14
172	2"1/2	AFS110ST	77,0	63	88,90	114	50,80	105	50	25	13,5	M12x45	1/2x1"3/4	4275	1,55
138	3"	AFS112ST	92,0	73	106,38	134	61,93	124	50	27	17,5	M16x50	5/8x2"	4337	2,33
34	3"1/2	AFS114ST	103,0	89	120,65	152	69,85	136	48	27	17,5	M16x50	5/8x2"	4387	2,40
34	4"	AFS116ST	115,5	99	130,18	162	77,77	146	48	27	17,5	M16x50	5/8x2"	4437	2,85
34	5"	AFS118ST (•)	142,0	120	152,40	184	92,08	180	50	28	17,5	M16x50	5/8x2"	4537	5,20

SERIE 6000

414	1/2"	AFS401ST012	21,5	13	40,49	57	18,24	46	36	16	9	M8x30	5/16x1"1/4	4075	0,24
414	1/2"	AFS401ST038	17,5	13	40,49	57	18,24	46	36	16	9	M8x30	5/16x1"1/4	4075	0,22
414	3/4"	AFS402ST	28,0	19	50,80	71	23,80	55	35	21	11	M10x40	3/8x1"1/2	4100	0,48
414	1"	AFS403ST	34,0	25	57,15	79	27,76	68	41	21	13	M12x45	7/16x1"3/4	4131	0,64
375	1"1/4	AFS404ST	42,8	32	66,68	93	31,75	78	44	25	15 *	M14x45	1/2x1"3/4	4150	1,00
320	1"1/2	AFS405ST	48,6	38	79,38	112	36,50	94	55	30	17	M16x50	5/8x2"	4187	1,68
250	2"	AFS406ST	61,0	51	96,82	134	44,45	114	65	37	21	M20x70	3/4x2"1/2	4225	2,86
230	2"1/2	AFS507ST	76,6	63	123,80	180	58,70	152	80	45	26	M24x80	-	4275	6,40
200	3"	AFS508ST	90,0	73	152,40	208	71,40	178	90	55	33	M30x100	-	4337	-

PER QUESTA TIPOLOGIA DI PRODOTTO, VERIFICATE SEMPRE SE LA QUOTA "A" E "B" CORRISPONDE ALLA SCHEDULA DEL VOSTRO TUBO

FOR THIS KIND OF PRODUCT, PLEASE ALWAYS VERIFY IF DIMENSION "A" AND "B" CORRESPOND TO THE SCHEDULE OF YOUR TUBE

DESIGNAZIONE PER ORDINE DESIGNATION FOR ORDER	Materiale / Material	
	ST52.3	AISI 316L
Solo flangia Only flange	AFS...ST	AFX...ST
Flangia completa di viti metriche, grower e o-ring Flange complete of metric screws, grower type washers and o-ring	AFS...STM	AFX...STM
Flangia completa di viti unc, grower e o-ring Flange complete of unc screws, grower type washers and o-ring	AFS...STU	AFX...STU

NOTE / NOTES

* Per viti unc L=13,5
* For unc screws L=13,5

(•) Solo in ST52.3
(•) Only in ST52.3

set viti unc disponibili solo in acciaio al carbonio.
unc screws set available only in carbon steel.