



Height Adjustable Standing Desk for Single Monitor (RWP1)



Integrated with pneumatic spring, using the workstation in standing or sitting .position



Color: Black
Suit Size: Single
13"-27" Monitor

Integrated with pneumatic spring, using the workstation in standing or sitting position with just a light lift of handle on right end of platform. The height of monitor and keyboard tray can be adjusted separately. The top surface have plenty space for a full size keyboard, general size mouse pad and working material. Unlike some competitor's products, this workstation can be risen and folded vertically with no forward movement. So the footprint will keep same during the up and down movement. Now you can work without sticking to your chair in full day. It will help to reduce your back pain, improve your blood circulation and shape your body.

This Single Monitor Sit-Standing workstation Fits mostly of 13"-27" Monitors. and it's easy to integrate it into your current layout by simple setting it on your desk.



The top surface have plenty space for a full size keyboard, general size mouse pad and working material

**Large Solid Base:
ensure it stay sturdy
and stable at any
height**

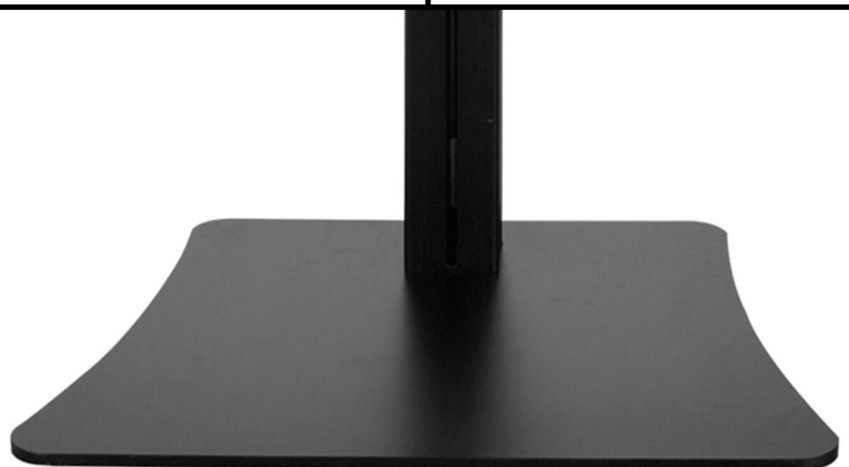

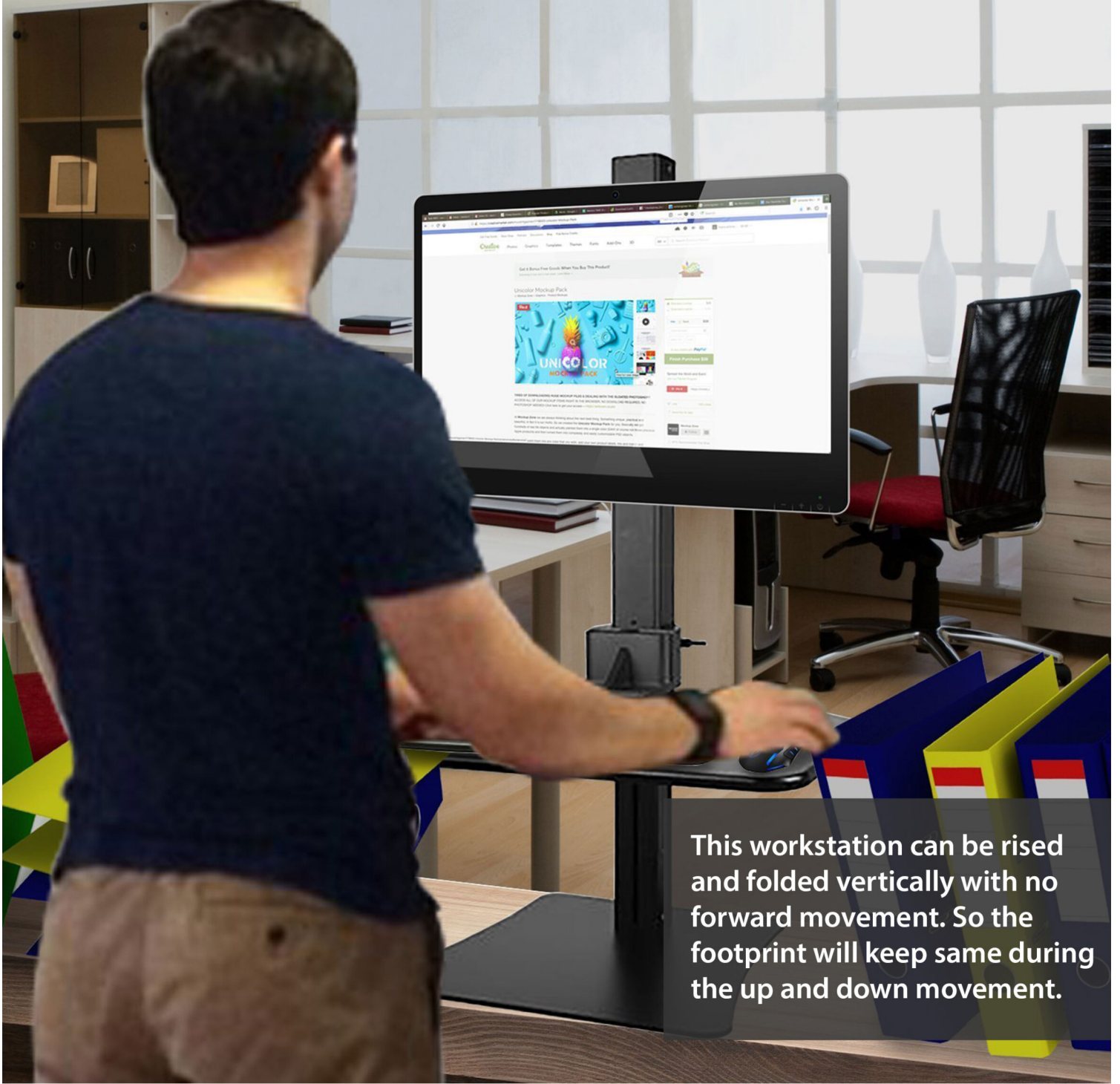

This workstation can be risen and folded vertically with no forward movement. So the footprint will keep same during the up and down movement.

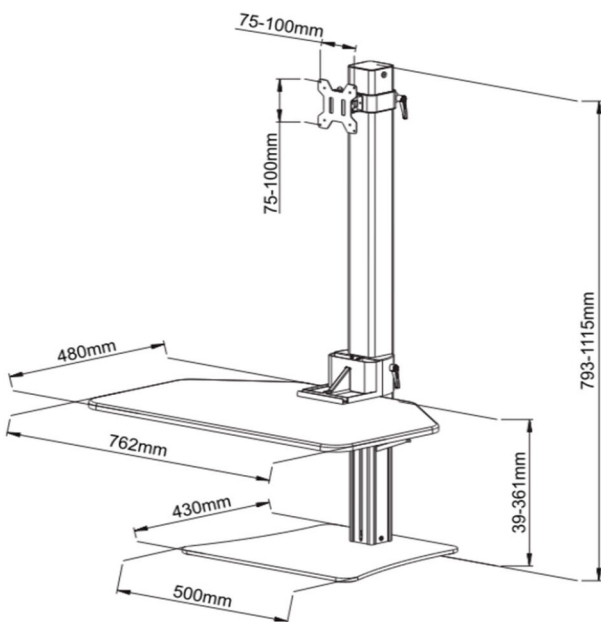

RWP1



Specification

1. Suit Size: Single 13"-27" Monitor
2. Load Capacity: Max 15.4 lbs / 7.0 kg
3. Height Adjustable for Keyboard Tray and Monitor (separately)
4. Keyboard Tray Size: 30" x 18.9" (762 x 480 mm).
5. Footprint: 19.7" x 16.9" (500 x 430 mm)
6. Main Material: MDF board, Steel and Pneumatic spring

Features

1. **Easy Lift:** Integrated with pneumatic spring, using the workstation in standing or sitting position with just a light lift of handle on right end of platform.
2. **Separate Height Adjustment:** The height of monitor and keyboard tray can be adjusted separately.
3. **Ergonomics Benefits:** Now you can work without sticking to your chair in full day. It will help to reduce your back pain, improve your blood circulation and shape your body.

Contact us



India: Rife Technologies, 362, Vardhaman Plaza - II, J Block Community Center. Rajouri Garden, Delhi - 110027, India
E-mail: sales@rifeindia.com, Website: www.lcdtvstandsindia.com , www.rifeindia.com, Tel:+91-9899250704

Hongkong: Ergonomic Corporation Hongkong Limited, 1102, 11th floor, 33 hysen Avenue, Lee Garden one, Causeway Bay, Hongkong
E-mail: sales@ergoshopping.com, Website: www.ergoshopping.com, Tel: 852-98226451