



MCT08



Computer Mobile Cart

Reap the ergonomic health benefits of this stand up workstation which is mobile also due to high quality lockable wheels . The height adjustable mount allows the monitor to be perfectly positioned to your liking while sitting or standing. MCT-08 workstation includes a sliding keyboard shelf and optional CPU holder, Printer shelf, Basket, Electrical socket . Designed with 4 casters, 2 of which are lockable, this cart can be to be stationed in one area or wheeled wherever necessary without difficulty. In addition to being height adjustable,



VESA Size: 75x75, 100x100, the mount tilts and rotates with ease to be viewed in either portrait or landscape orientation.

Designed with 4 casters, 2 of which are lockable, this cart can be to be stationed in one area or wheeled wherever necessary without difficulty



This height adjustable sit-stand mobile Cart enables you to change frequently between a seated working position to a standing one easily

Locking Rotary Knob
ensures a secure position at
any height & angle setting



VESA 75x75, 100x100 ideal
for Monitor Size Range, (inches)
17 to 27 inches

Easy-Grip Handle

The floating **CPU holder**
is height and width
adjustable to fit almost
any desktop computer



Plenty Space
for a full size keyboard,
general size mouse pad
and working material

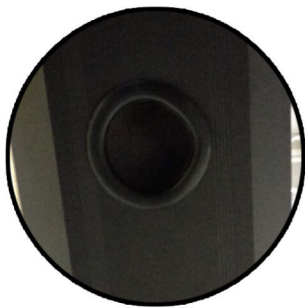

Integrated Cable Management System
Internal Cable Management allows cables
and wires to be routed inside the column
for a clean, clutter free look



Use this ergonomic cart in your office, school, or other professional setting as a workstation that is constructed to meet your needs. This device gives the convenience of moving an entire computer system to any place where users need it to be. This is best for commercial, medical and industrial facilities where some mixed furniture locations are not preferred. Because it's mobile, this computer workstation stand cart offers the best flexibility of adapting to any changes in the working environment. It accepts all the components of your workstation, including keyboard, mouse, LCD display, CPU, laptop, printer, and power supplies.



Create a Premium Audio and Video Conferencing System

Also Compatible with
NEW
Polycom Studio

Can use with on top of Camer Shelf (Optional) and Keyboard Tray.



With room-filling sound and pinpoint accurate microphones, Polycom Studio enables participants on both ends of your calls to hear and be heard clearly. Developed through decades of audio science, Polycom Studio has the best audio quality in its class, letting you experience meetings like you're there in person. With intelligent features like Polycom Acoustic Fence and Noise-Block, Polycom Studio automatically mutes and removes distracting background noises and other unwanted sounds.



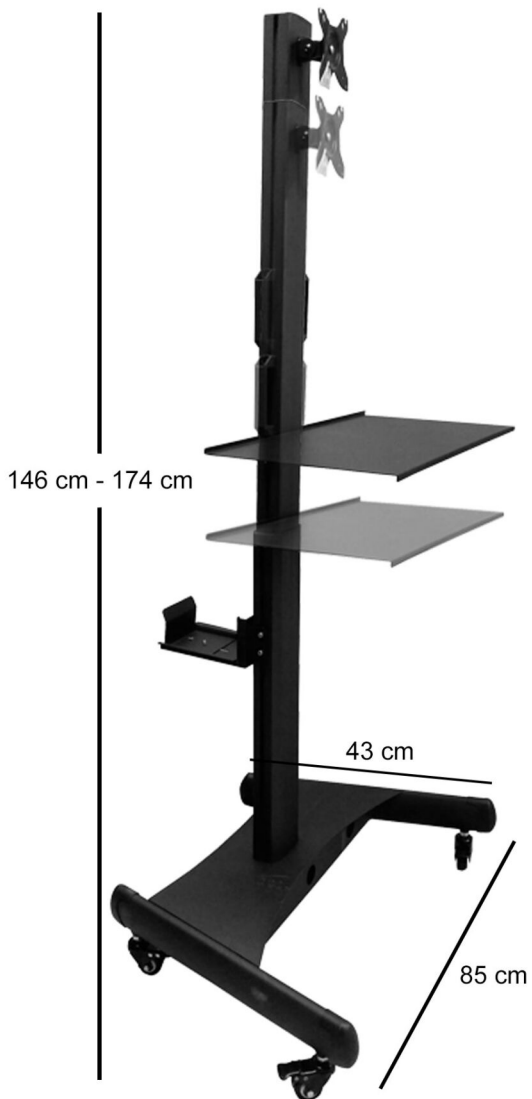

CPU Holder
 The Floating high and width holder to fit almost any desktop computer



Features

1. **Wheels, Tilting, Adjustable Height, Height Adjustable Shelves**
2. **Base Width x Height x Depth: 24.3" x 5.3" x 22.0"**
3. **Material : Steel, Aluminum**
4. **VESA Size : 75x75, 100x100**
5. **Pull-Out Shelf Width x Depth: 25.3" x 14.5"**
6. **Monitor Size Range, (inches): 17 to 27 inches.**
7. **Height from base to top of pillar is fix 1800 mm.**

Contact us



India: Rife Technologies, 362, Vardhaman Plaza - II, J Block Community Center, Rajouri Garden, Delhi - 110027, India
 E-mail: sales@rifeindia.com, Website: www.lcdtvstandsindia.com, www.rifeindia.com, Tel:+91-9899250704

Hongkong: Ergonomic Corporation Hongkong Limited, 1102, 11th floor, 33 hysen Avenue, Lee Garden one, Causeway Bay, Hongkong
 E-mail: sales@ergoshopping.com, Website: www.ergoshopping.com, Tel: 852-98226451