

Installation Instruction

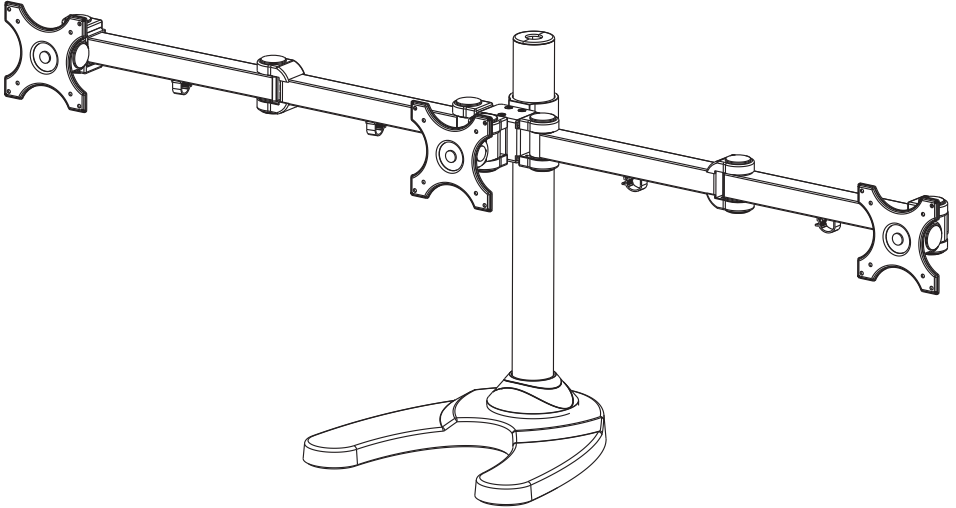

UNPACKING INSTRUCTIONS

- Carefully open the carton, remove contents and lay out on cardboard or other protective surface to avoid damage.
- Check package contents against the Supplied Parts List in the next page to assure that all components were received undamaged. Do not use damaged or defective parts.
- Carefully read all instructions before attempting installation.

IMPORTANT SAFETY INFORMATION

- Install and operate this device with care. Please read this instruction before installation, and carefully follow all instructions contained herein. Use proper safety equipment during installation.
- Please call a qualified installation contractor for help if you don't understand these directions or have any doubts about the safety of the installation.

Do not use this product for any purpose or in any configuration not explicitly specified in this instruction. We hereby disclaims any and all liability for injury or damage arising from incorrect assembly, incorrect mounting, or incorrect use of this product.

Supplied Parts List

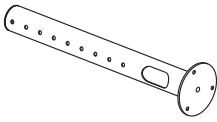

(1) 48mm Pole-a

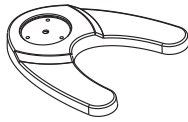

(1) Weighted Base-b

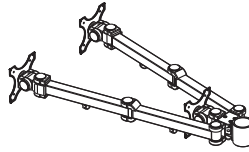

(1) Monitor Arm-c



(1) Plastic Cover-d



(1)M10 Bolt-e



(1)Support Plate-f

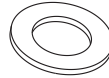

(1)M10 Washer-g

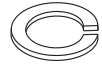

(1)Spring Washer-h



(2)M8x10 Bolt-i

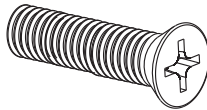

(3)M6x29 Bolt-j

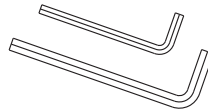

(1)Allen Key-k

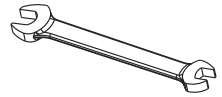

(1)Wrench-l

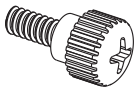

(12)M4x12
Thumb Bolt-m

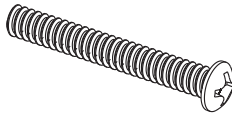

(12)M4x30 Bolt-n

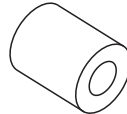

(12)M4 Space-o

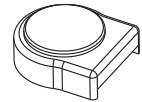

(2)Spare Cover-p

Tools Required

Phillips Screwdriver



WARNING

CAUTION!

This monitor desktop mount must be securely installed to the horizontal desk. If the mount is not properly installed it may fall, resulting in possible injury and/or damage.

Step 1**Mounting the base according to your requirement**

The stand can be used with the weighted metal base or there is a desk attachment provided (as drawings on the bottom) allowing you to mount the stand on a desk. This is very simple to install and just requires a hole drilling (10mm diameter) in your desk and clamping with the bolt and large washer.

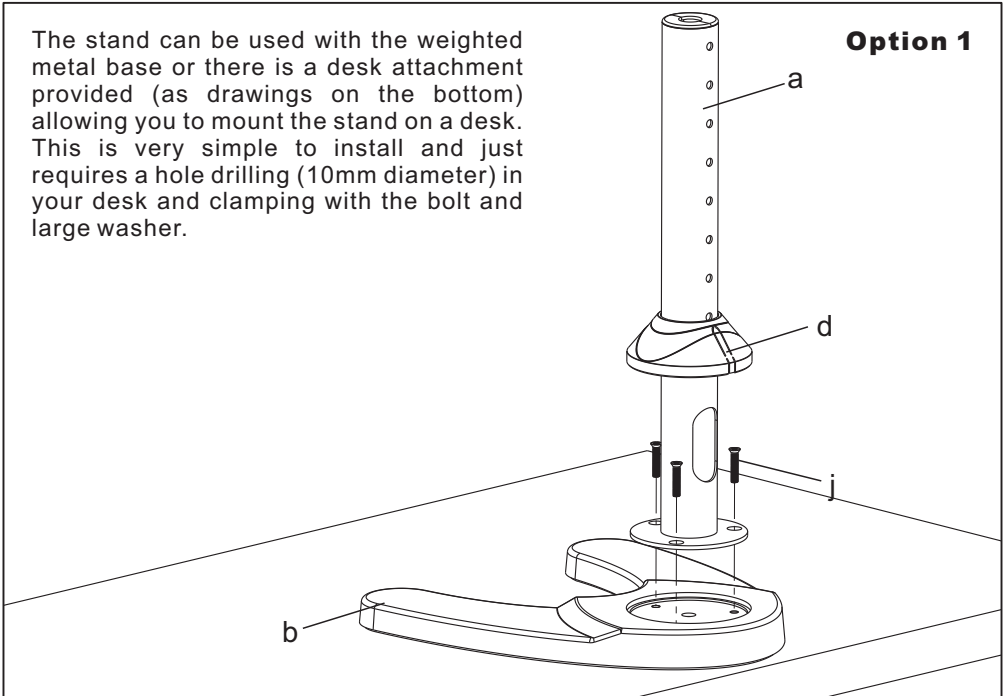
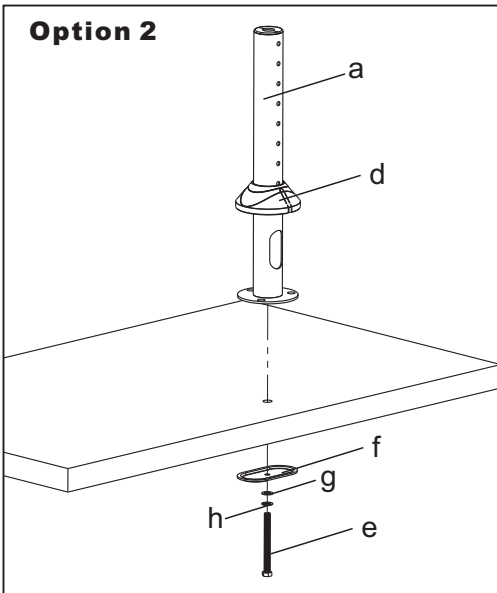
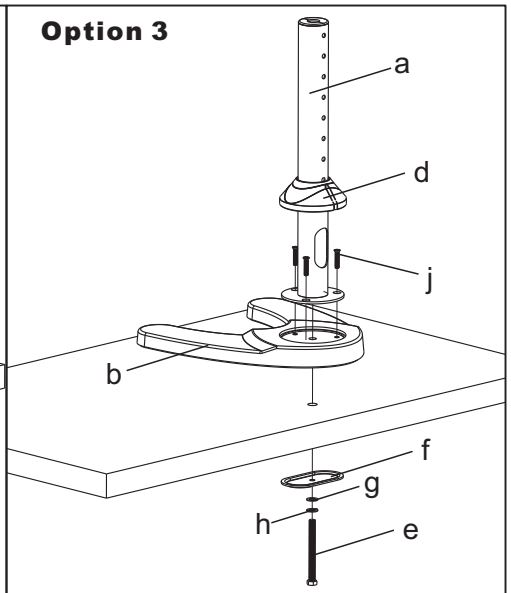
Option 1**Option 2****Option 3**

Step 2**Install Monitor Arm to the Pole**

Install monitor arm to the pole, please make sure the wire clip in the downside. Fasten the M8x10 bolt(i) by screw driver.

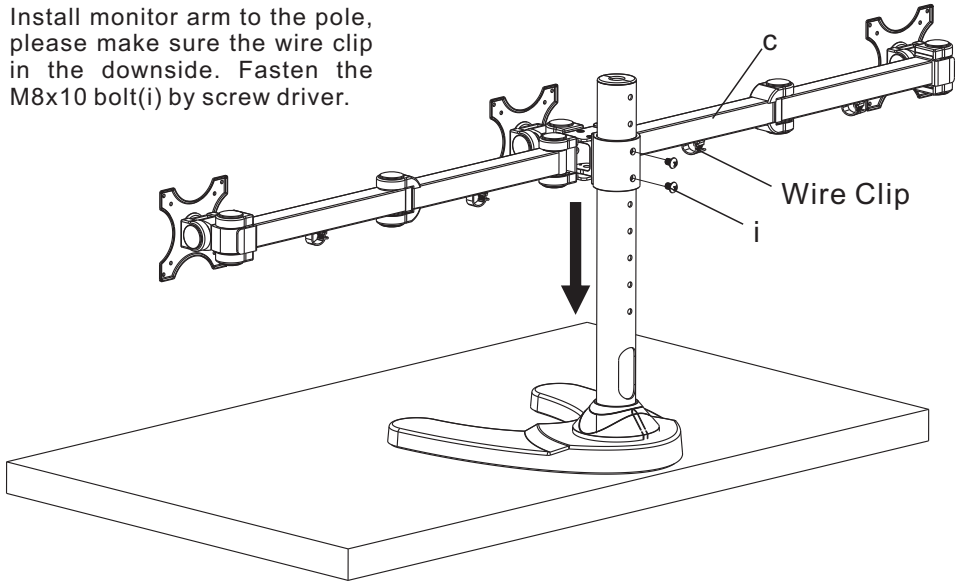
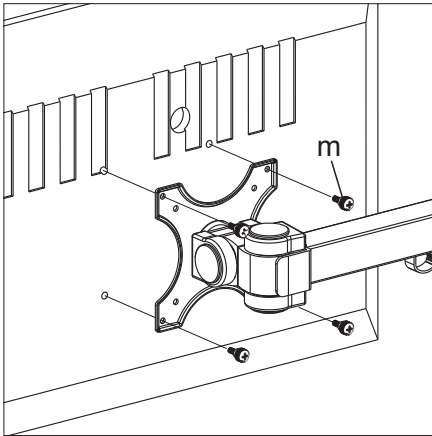
**Step 3****Mount the Monitor to VESA Plate**

For Flat Back Monitor

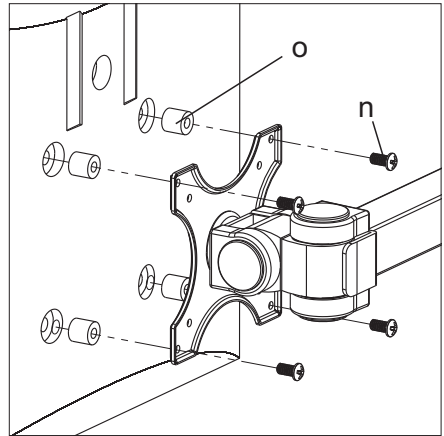

For Curved Back Monitor

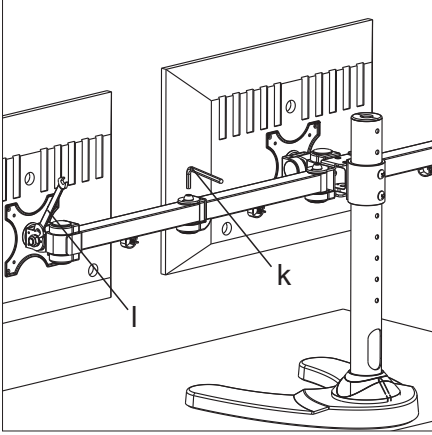
Step 4**Do the Necessary Adjustment**

Use the Allen Key(k) to adjust the turning tension. Use the Wrench(l) to tighten the nut if the tilt angle can not be fixed.

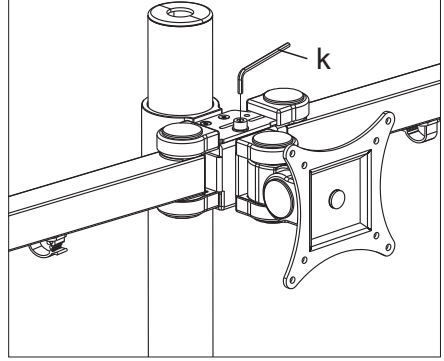
Level Adjustment

Turn the bolt counterclockwise to lower the center monitor, turn the bolt clockwise to raise the center monitor.

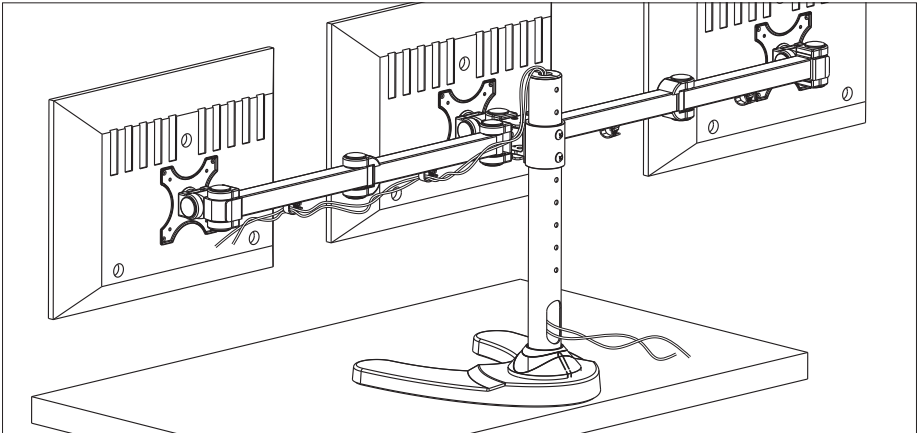
Step 6**Manage the Wires**

Thank you for choosing our products!