

Ki

SMART WIFI DOORBELL

Quick Start Guide

HD



1. PRODUCT DRAWING – FRONT

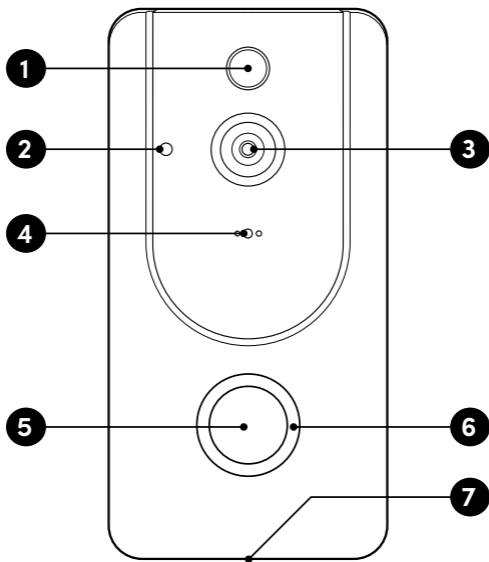

1. PIR Motion Sensor
2. Light Sensor
3. 166° HD Camera
4. Microphone

5. Push Button
6. LED Indicator
7. Speakers

2. PRODUCT DRAWING – BACK

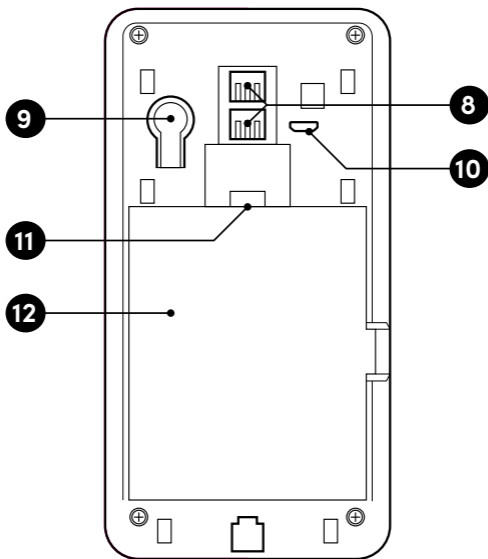

8. AC14V~24V Power Interface

9. Reset Button

10. Micro USB Port
(Battery Charging)

11. SD Card Slot

12. Battery Compartment Cover

3. PRODUCT DRAWING – MOUNTING BRACKET

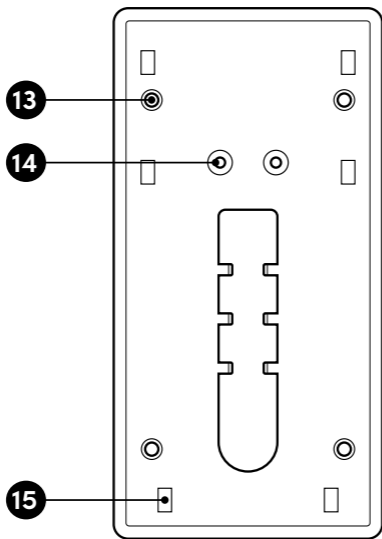

- 13. Screw Holes x 4
- 14. Wire Terminals
- 15. Mounting Hooks x 6

4. PRODUCT DRAWING – BRACKET INSTALL

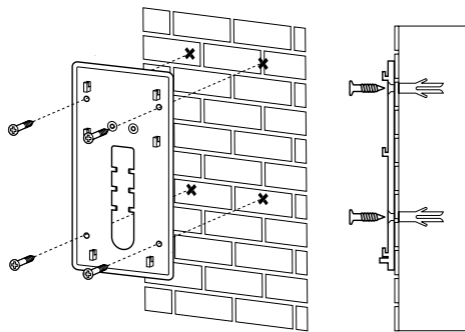

1 Push in and slide down

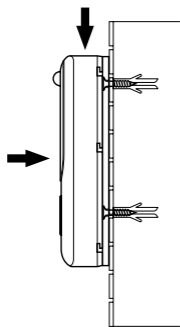

2 Tighten to secure

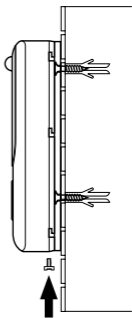

3
Tighten screw
at base,
use provided
Allen Key

5. POWER SUPPLY

Hard wire power source

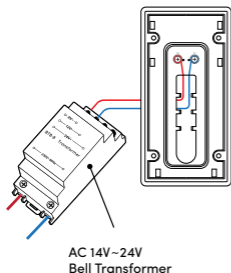

Powered by battery

Micro USB port
for battery
charging (DC5V)

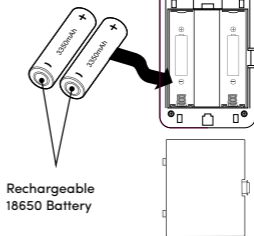

6. APP DOWNLOAD – SMART LIFE



Download from App Store or Google Play, run the app on your smart phone and set up the smart video doorbell, following the in-app instructions.

7. SMART WIFI VIDEO DOORBELL PARAMETERS

Smart WiFi Video Doorbell security solution provides the following functions: wireless connection, ultra-low power consumption, remote active wake-up and quick start.

Main Processor	Hi3518E
Sensor	1/4 COMS OV9732
Video	1280*720@25fps
	H.264 Bitrate self-adaptive
	Suitable for changeable network environments(3G,4G or WIFI)
Audio	Two-way voice & Support echo cancellation
	Built-in speaker
	Built-in Microphone
View Angle	166 degree Horizontal
Day & Night	IR-CUT double filter automatically switches
	6pcs infrared LED 850nm
	Min Illumination:1 Lux
Connection	Support WiFi 2.4 GHz, IEEE 802.11 b/g/n
	AP Hot spot
	Scan QR code
Storage	Support SD card 8G / 16G / 32G
Recording	Support smart phone local record, records video playback
	Optional recording time setting between 15s -45s, once doorbell triggered
Screen Shot	Support Smart phone screen shots
Working Condition	Press Button Directly
	PIR detection triggered
	Mobile phone Control
Running up	System running up in millisecond
Inform	Push message within 1s-2s
Motion Detection	PIR motion detection, sensitivity High(2s)/ Medium(within 5s)/ Low (within 10 s)
Scene Mode	Backlight compensation
	Infrared night vision
	Quick movement
	HLC
	D-WDR
Share	Support QR code share(one-click generates QR-code, share to others
	To add your doorbell devices, join in remote control. Maximum supports 7 authenticated users, supports users 3 view at the same time
Battery	3.7V, 2pcs 18650 battery, 3350mAh, Rechargeable or (14V-24V AC charging)
Power Consumption	Working 170mA, Standby 160μA

8. APP GUIDE

Download Smart Life app on mobile phone. Open the app and you will see the following guide page .

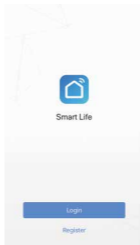
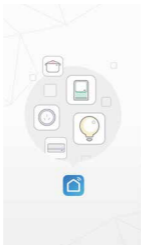

9. USER REGISTRATION

Register a new account. If you already have an account, simply log in.

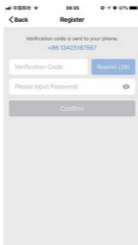

10. ADD DEVICE

Select the following options "Add Device > Security & Video Surveillance > Smart Doorbell"

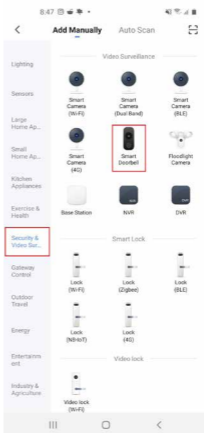

11. GENERAL CONNECTION

Remove "PULL" tags from back of the device (if not done so already). You should now hear a voice and the LED indicator should now be flashing red.

In the app, select "Make sure the indicator is flashing quickly or a prompt tone is heard". Then select "Next".

Enter your WiFi password and confirm.

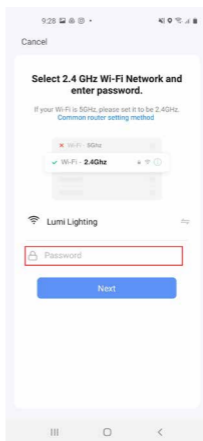
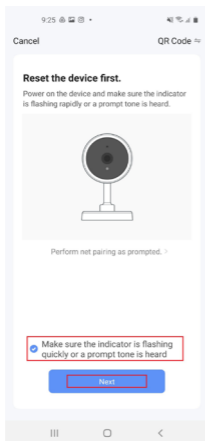

12. QR CODE CONNECTION

Hold the QR code up to the camera of the Ki device. You should hear a chime. Select "I heard a prompt". Wait for the device to be added.



If the connection fails, ensure you have entered the correct password (the app won't specifically tell you that the password is incorrect). If the connection fails again, press the 'reset' button on the back of the device and reconnect your Ki to the app.

If you have tried the above and are still having issues, it is likely to be caused by one of the following:

Poor strength of your wifi signal from the doorbell location.

Already paired to another smartphone (ie, family member/builder/electrician). A new smartphone not be added if old user still has their phone connected to the Ki. To remove the Ki from a smartphone, navigate to the home screen in the Smart life app and press the "settings" icon in the top righthand corner, then scroll down to the bottom and press "remove device"

Low power. Recharge/replace batteries and ensure there is power coming out of the wall.

Smartphone connected to a weak wifi source.

13. QR CODE CONNECTION

DEVICE CONNECTION STATUS DESCRIPTION

1. The red light is always blinking.
 - ▶ Ready to connect to network mode, after a few seconds of waiting, with tone reminder.
2. Flashing red, light blinks at one second intervals.
 - ▶ The device has entered the network connection mode. If the device successfully receives the broadcast or detects QR Code, there will be prompt tone reminder.
 - ▶ If the device failed to enter connection mode, possibly: 1) The WiFi router does not support broadcast transmission. We suggest to change QR code mode for connection. 2) It may detect QR code failed. We recommend to highlight the light of smartphone screen. Put it directly in front of doorbell lens.
3. The blue light is always blinking.
 - ▶ The device has entered the connection mode.
 - ▶ If the device failed to connect with network, possibly: 1) It may have timed out due to configuring to the correct WiFi account but using wrong WiFi password. Device will stay unconnection status. We suggest reconfiguration of the network. 2) Device has been bound by other user's smartphone. We suggest deleting the device and reconfiguring the network.
4. The red light and blue light alternatively blink once every one second; device in normal standby mode. After wake up status, if it remains unchanged, the device didn't enter connection mode.
5. The blue light blinks once every one second; device in normal standby mode. After wake up status, if it still remains unchanged, the device entered connection mode properly.

14. DEVICE MANAGEMENT

Click "..." on live view page to enter device management.

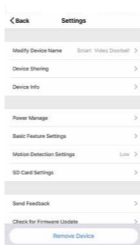
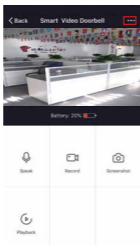

15. MODIFY DEVICE NAME

Click "Modify Device Name" on setting page to rename device .

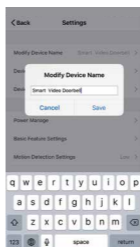
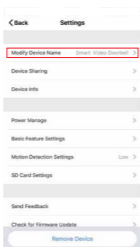

16. DEVICE SHARING

To share your Ki device with another user, navigate to the home screen and follow the following prompts highlighted in the images below:

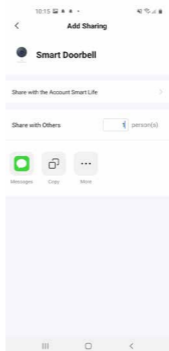
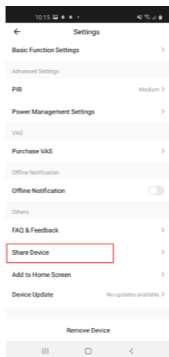
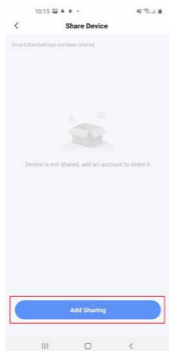
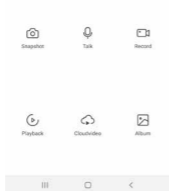

17. DEVICE INFO

Click "Device Info" to check device information.

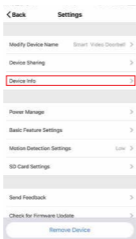

18. POWER MANAGEMENT SETTING

Click "Power Manage" to check power working status.

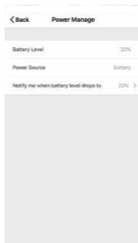
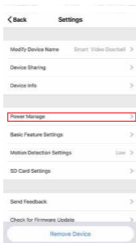

19. BASIC FUNCTION SETTING

Click "Basic Function Settings" to set below functions: Indicator status; image reverse; time watermark; wide dynamic mode; IR night vision.

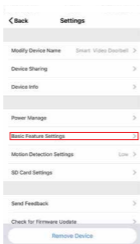

20. MOTION DETECTION SETTING

Select "PIR" to set the sensitivity of the camera.

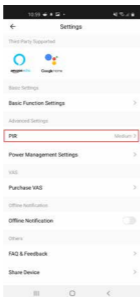

21. DOORBELL CALL PUSH MESSAGE

Press doorbell and it rings. Device makes call to smartphone, select "Accept" to check the monitoring image or "Refuse" to end call.



22. PIR MOTION DETECTION PUSH MESSAGE

Select push message to be notified if people stay in front of the device or move. Device will and start recording.

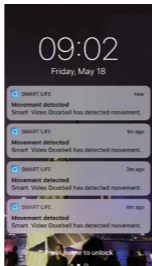

23. MESSAGE CENTER

Click "Message Center" to check the history of push messages.

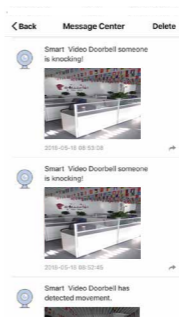
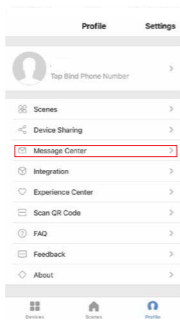



Telephone 1300 LIGHTS
Facsimile +61 3 9645 6574
Email sales@amphis.com.au

amphis.com.au

KĪ TROUBLE SHOOTING

STEPS FOR PROBLEM DIAGNOSIS

MY KĪ IS NOT OPERATING

The unit will need to be fully charged for at least 24 hours prior to operating. When the unit is charged, all device management functions (recordings, battery/power, device sharing, motion sensor etc.) can be accessed from the app. If the unit is hardwired (product code 108018HW), the hardwiring component will 'trickle charge' your unit.

A. Charge/restart your KĪ

You will require a universal micro USB cable and a phone adapter.

1. Detach the KĪ from the wall mount (if already installed). Remove the bottom screw and push the unit upwards to detach the unit from wall mount.
Note: There is a screw at the bottom and six upward L-hooks² on the wall mount that may break if pushed too hard.
2. Insert the two batteries provided. This acts as a back-up power supply.
3. Connect the KĪ, micro USB cable and phone adapter to wall socket. Hold down restart button until unit prompts are heard. The restart button is located at the back of the unit.

MY KĪ IS NOT PAIRING

Completion of step A above is required. Refer to sections 8 to 12 in the instruction manual (available on the Amphis website) when following step B.

B. Step-by-step checklist

1. Ensure the correct app is downloaded. If QR code does not work, check in the App Store/Play Store for '[Smart Life](#)'. Section 8 - select the correct logo.
2. Select 'Smart Door Bell' in the app. This can be found in the Video Surveillance category. Section 10 - app interface may look different due to software updates.
3. Check that only one admin device does the initial pairing, then invite other devices via invitation³.
4. Ensure that the WIFI connection is good and action according to screen instructions and when prompts are heard.

MY KĪ SAYS 'DEVICE HAS ALREADY BEEN CONNECTED TO ANOTHER USER'



The unit may have been paired by trade to check that it is in working order and the device was not removed from the app prior to handover.

C. Contact Amphis to speak to a team member

Please email warranty@amphis.com.au with the following details⁴:

1. Name, contact number, builder contract/job number and a screenshot of the 'binding prompt'.

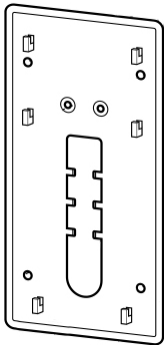
FOOTNOTES

FOOTNOTES	CLARIFICATION
1	<p>The hardwiring component will 'trickle charge' the unit, ie. regularly top up power. An additional 15W DC transformer (not included) will need to be wired from the unit to the main power supply.</p>
2	<p>The wall mount consists of six upward L-shape brackets.</p> <p>There is a screw at the bottom of the unit that secures the unit to the wall mount. This will need to be removed before detaching the unit.</p> <p>To detach the unit from wall mount, push upwards to release from L-hooks and pull away from wall.</p> 
3	<p>One admin will need to set up the device using the Smart Life app. Pairing secondary devices is only possible by sharing/invitation from the admin device. Do not create a Smart Life account prior to receiving an invitation from an admin device.</p>
4	<p>Name and contact number for communication.</p> <p>Job/contract number to locate the order (if this is not available to you, the home address is required)</p> <p>One of the below examples is required (refer to images):</p> <p>A photo of the device ID sticker located at the back of the unit on the battery lid.</p>  <p>A screenshot of the ticket details showing the 'ticket number' (This will appear when you select 'Apply to Unbind' on the app)</p> <div style="display: flex; justify-content: space-around;"> <div data-bbox="341 1630 831 1839"> <p>Failed to add to group</p>  <p>Smart Doorbell</p> <p>This device has been connected to another user and cannot be connected again. First log in to the old account and remove it, or contact our customer service personnel Apply to Unbind</p> </div> <div data-bbox="863 1621 1423 1868"> <p>Ticket details</p> <p>To-Be-Supplemented FBEU202202010024</p> <p>Device unbinding request/Device unbinding</p> <p>Equipment name: Smart Doorbell Description: Need to reset my door bell as I have</p> </div> </div>