



106512

CORA 12

PLYWOOD PENDANT

INSTALLATION MANUAL

Thank you for purchasing this quality Amphis product. Please read carefully before installation.

WARRANTY

This Amphis product is covered by a 3-year residential warranty. The warranty period starts from date of purchase. Proof of purchase will be required.

Warranty will be void if the luminaire is not assembled and installed by a licensed electrician, is used with a non-compatible dimmer, or if there is any damage due to improper usage or modification to the luminaire.

SPECIFICATIONS

Model Number 106512

Input Voltage 220-240V AC

Safeguard Grade Class 1

Ingress Protection IP65

Colour / Finish American oak, sassafras or walnut

Materials Plywood, aluminium and acrylic

Dimensions (mm) W1170 x D60 x H90

Weight 2900g

Suspension 1900mm

Dimmable Yes

Globe In-built LED

Warranty 3 Year Residential

SAFETY INSTRUCTIONS

- Always ensure the power is OFF and the luminaire has cooled down before performing any maintenance, cleaning or making any adjustment to the luminaire.
- Ensure that power leads and screws are secure before connecting the power.
- Select a suitable location away from liquids and hazards.
- To clean, wipe with a soft damp cloth. Do NOT soak or immerse the luminaire in water or other liquids.
- Ensure that the luminaire does not come in contact with corrosive chemicals/solvents or abrasive cleaners etc.
- The light source of this luminaire is not replaceable; when the light source reaches its end of life, the whole luminaire needs to be replaced. There are no serviceable parts. Do not attempt to dismantle or open the product.

INSTALLATION REQUIREMENTS

- This luminaire must be assembled and installed by a licensed electrician.
- All wiring and installation of the luminaire must adhere to the latest local and national wiring rules, e.g. AS/NZS 3000 Electrical Installations. Do not exceed the maximum wattage rating.
- The luminaire is a Class 1 product and must be earthed during wiring and installation.
- Select a suitable location for installation:
 - This luminaire is suitable for indoor use only.
 - The mounting point must support two times the weight of the luminaire.
 - Ensure the luminaire is not installed in direct line of an air vent/system.
 - If installing a luminaire in an area prone to moisture, ensure that the area is well-ventilated and an appropriately-rated exhaust fan is used if required. Damage or corrosion caused by moisture is not a product fault and is therefore not covered under warranty.
- Lay out all the components on a smooth surface and make sure no components are missing before assembling.
- If there are any missing parts, please contact Amphis's warranty department on 1300 LIGHTS (1300 544 487) or email warranty@amphis.com.au
- Do not operate or install any product that appears damaged in any way. Return the complete product to Amphis for inspection, repair or replacement.

INSTALLATION DIRECTIONS

NOTE Ensure power to the circuit has been switched OFF before commencing.
Due to the size of the luminaire a second person may be required to lift it during the installation process.

- 1 Remove the product and accessories from packaging and place them on a smooth non-scratch surface.
- 2 Remove the mounting brackets (M) from the canopies (E) by loosening the screws (F) on the side.
- 3 Use the mounting brackets (M) as a template to mark the screw positions on the ceiling. The centres of the two mounting brackets are to be placed 861mm apart.
- 4 Install the mounting brackets (M) onto the ceiling by using appropriately-sized mounting screws (L) and anchors (N). Ensure the screws (L) and anchors (N) used are suitable for the mounting surface and the surrounding environment. See Figure 1.
- 5 Connect the mains supply wire to the terminal block (H). Connect the mains earth to the terminal block (H). See Figure 2.

Mains Supply Wire	Luminaire Wire / Terminal Block
Earth - Yellow/Green	Yellow/Green or ⊕
Neutral - Blue or Black	Blue or N
Live - Brown or Red	Brown or L

NOTE The luminaire is a Class 1 product and must be earthed during wiring and installation.

- 6 Ensure the wires are secure and no bare wires are exposed.
- 7 Determine the approximate pendant drop required. Thread the strain relief (G) onto the flex cable (C). Affix the wire end stoppers (K) to the two cables (B). See Figure 3.
- 8 Screw in the cable grips (D) and secure the terminal block (H) to the canopy (E) with the lock washer (I) and hexagonal nut (J). See Figure 3.
- 9 Install the two canopies (E) onto the mounting brackets (M) and secure by tightening the screws (F) on the sides.
- 10 The luminaire suspension length can be adjusted by pushing up on the base of the cable grips (D).
- 11 After the installation is complete, switch on the luminaire to test and enjoy your new lighting product.

CORA 12 - INSTALLATION MANUAL

Components

- A Lighting fixture
- B Suspension cable
- C Flex cable
- D Cable grip
- E Canopy
- F Canopy fastener
- G Strain relief
- H Terminal block
- I Lock washer
- J Hexagonal nut
- K Wire end stopper
- L Screw
- M Mounting bracket
- N Anchors

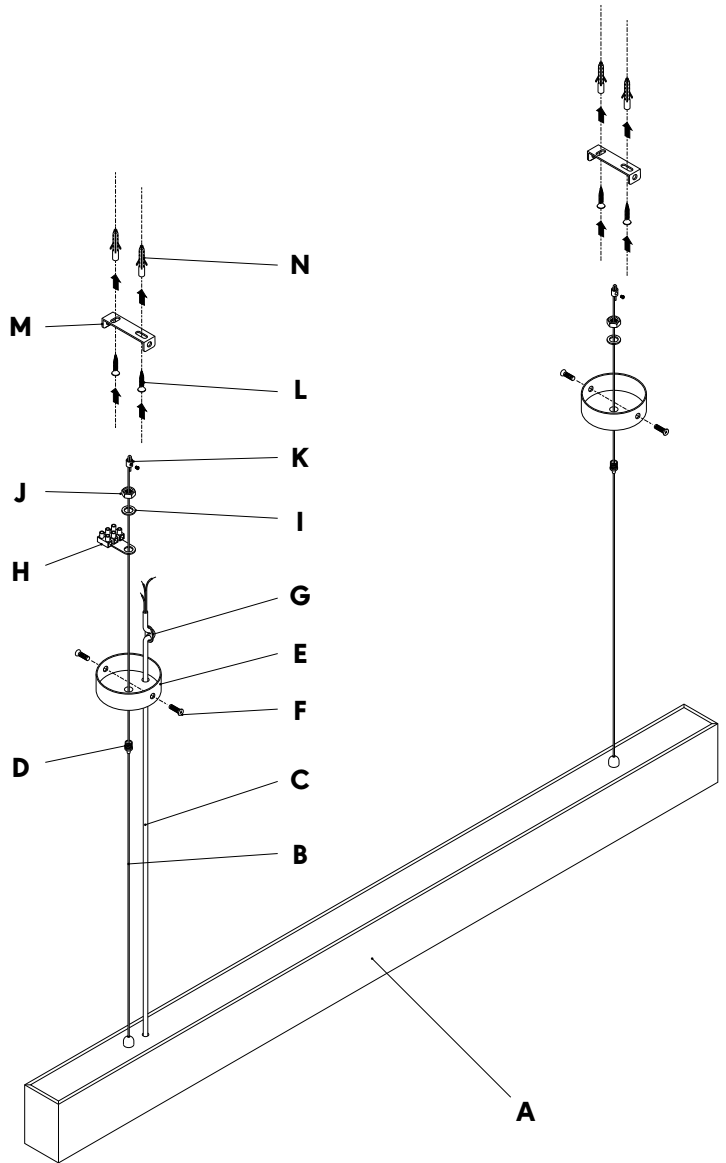

CORA 12 - INSTALLATION MANUAL

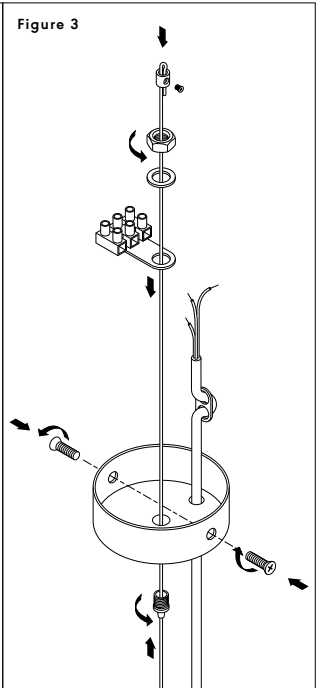
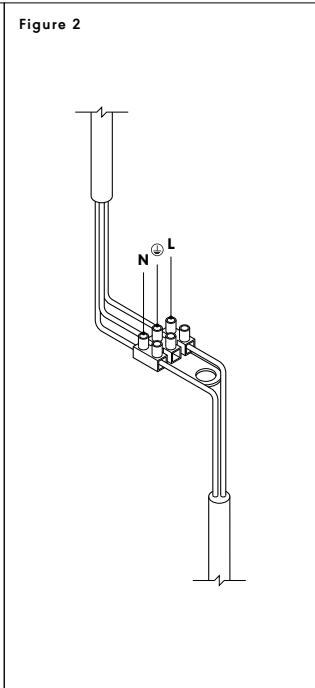
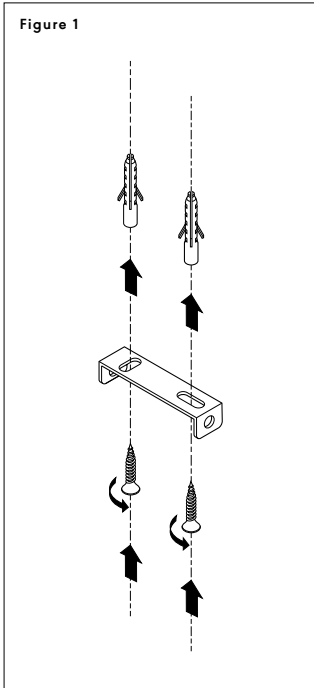
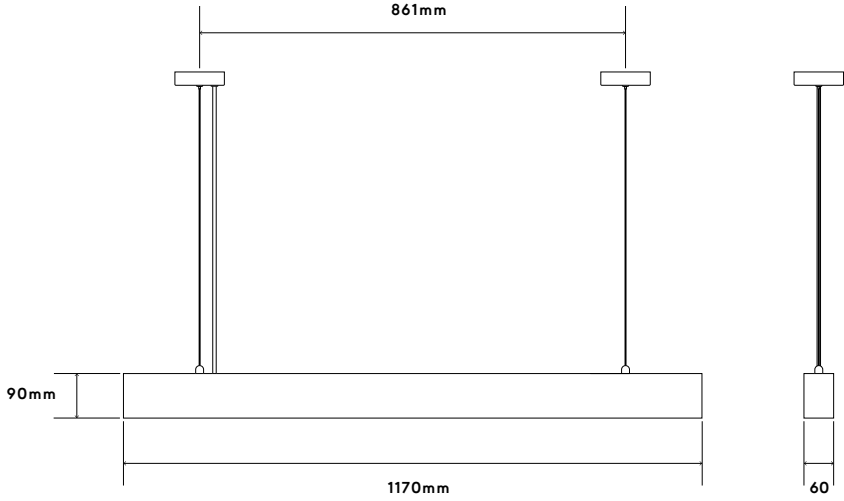

TROUBLESHOOTING

Problem	Possible Cause	Suggested Solution
Does not turn on. (New installation)	Loose wiring or no power to the luminaire.	Check your circuit breaker/safety switch box and turn on the power to your circuit.
		Contact the installing licensed electrician to check if the luminaire has been installed correctly.
Does not turn on. (Existing installation)	No power to the luminaire.	Check your circuit breaker/safety switch box and turn on the power to your circuit.
		Contact warranty@amphis.com.au

To the best of our knowledge, the information contained herein is accurate and reliable as of the date of publication; however, Amphis Pty Ltd does not assume any liability whatsoever for the accuracy and completeness of the information.

Amphis Pty Ltd makes no warranties which extend beyond the description contained herein.

Any information given in this statement does not constitute any warranty of merchantability or fitness for a particular use. It is the customer's responsibility to inspect and to test our products in order to satisfy themselves as to the suitability of the products to their particular purpose.



Telephone 1300 LIGHTS

Facsimile +61 3 9645 6574

Email sales@amphis.com.au

amphis.com.au