



GAZEBO

**FAIRHAVEN**

3.6m x 3.6m

ASSEMBLY GUIDE



the 1990s, the number of people with a mental health problem has increased in the UK (Mental Health Act 1983, 1990).

There is a growing awareness of the need to improve the lives of people with mental health problems. The Department of Health (1999) has set out a vision of a new mental health system, which will be based on the following principles:

- People with mental health problems should be treated as individuals, with their own needs and wishes.
- People with mental health problems should be given the opportunity to participate in decisions about their care and treatment.
- People with mental health problems should be given the opportunity to live in their own homes and communities.

The Department of Health (1999) has also set out a vision of a new mental health system, which will be based on the following principles:

- People with mental health problems should be given the opportunity to live in their own homes and communities.
- People with mental health problems should be given the opportunity to participate in decisions about their care and treatment.
- People with mental health problems should be treated as individuals, with their own needs and wishes.

The Department of Health (1999) has also set out a vision of a new mental health system, which will be based on the following principles:

- People with mental health problems should be given the opportunity to live in their own homes and communities.
- People with mental health problems should be given the opportunity to participate in decisions about their care and treatment.
- People with mental health problems should be treated as individuals, with their own needs and wishes.

The Department of Health (1999) has also set out a vision of a new mental health system, which will be based on the following principles:

- People with mental health problems should be given the opportunity to live in their own homes and communities.
- People with mental health problems should be given the opportunity to participate in decisions about their care and treatment.
- People with mental health problems should be treated as individuals, with their own needs and wishes.



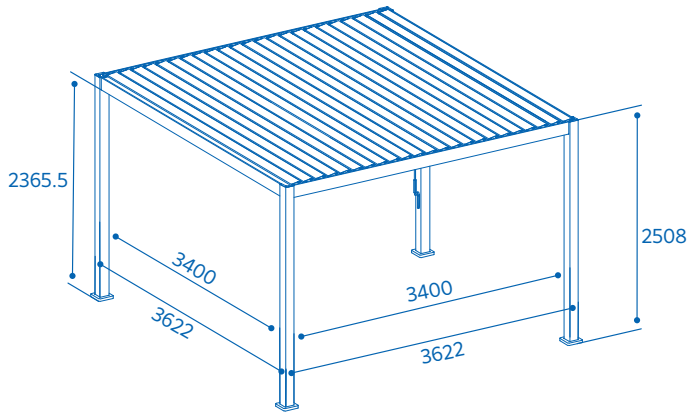

The Department of Health (1999) has also set out a vision of a new mental health system, which will be based on the following principles:



- People with mental health problems should be given the opportunity to live in their own homes and communities.
- People with mental health problems should be given the opportunity to participate in decisions about their care and treatment.
- People with mental health problems should be treated as individuals, with their own needs and wishes.

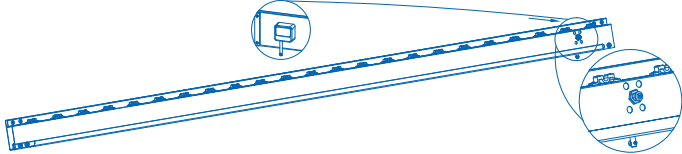

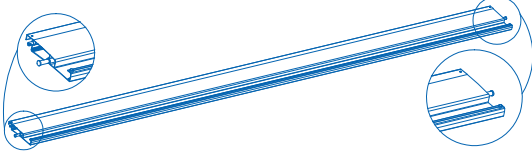
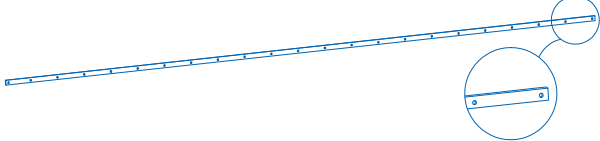

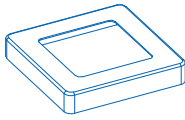
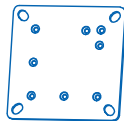
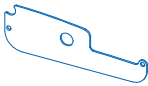
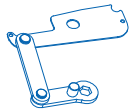
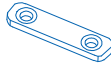
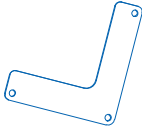

## PARTS SUMMARY

	REF	QTY	REF	QTY	REF	QTY
Carton 1/4	(A)	4 pcs	(I)	4 pcs	(J)	4 pcs
	(K)	47 pcs	(L)	1 pc	(M)	48 pcs
	(N)	4 pcs	(O)	24 pcs	(P)	96 pcs
	(Q)	96 pcs	(R)	12 pcs	(S)	27 pcs
	(W)	16 pcs	(X)	1 pc	(V)	1 pcs
	User Manual	1 set			(Y)	2 pcs
Carton 2/4	(B1)	1 pc	(B2)	1 pc	(C)	2 pcs
	(G)	1 pc	(H)	1 pc		
Carton 3/4	(D)	12 pcs				
Carton 4/4	(D)	11 pcs				

REF	PICTURE	QTY
A		4 pcs
B1		1 pc
B2		1 pc
C		2 pcs
D		23 pcs
G		1 pc
H		1 pc

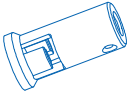
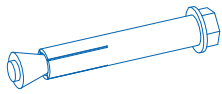
REF	PICTURE	QTY
I		4 pcs
J		4 pcs
K		47 pcs
L		1 pc
M		48 pcs
N		4 pcs
O		24 pcs
P	 M5x12mm	96 pcs

REF	PICTURE	QTY
Q	 4.2x25mm	96 pcs
R	 5.5x19mm	12 pcs
S		27 pcs
V		1 pc
W		16 pcs
X		1 pc
Y		2 pcs

# ASSEMBLY

---

## STEP 1

Check that no parts are missing from the four boxes. Ensure you have the required tools and safety equipment shown in figure 1.

Gloves



Knife

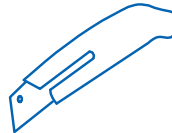

Mallet



Hard Hat



Tape Measure

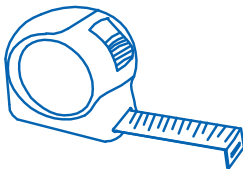

Driver

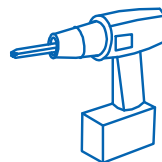

Ladders

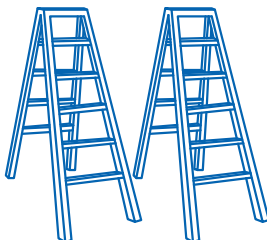

Figure 1.

## STEP 2

Slide a collar (I) over the bottom of one of the posts (A) as shown in figure 2, with the rounded part of the collar facing towards the top of the leg. Position base plate (J) over the bottom of the leg section and affix to the leg using 6 bolts (O). Repeat this process for the other three legs.

×4 times

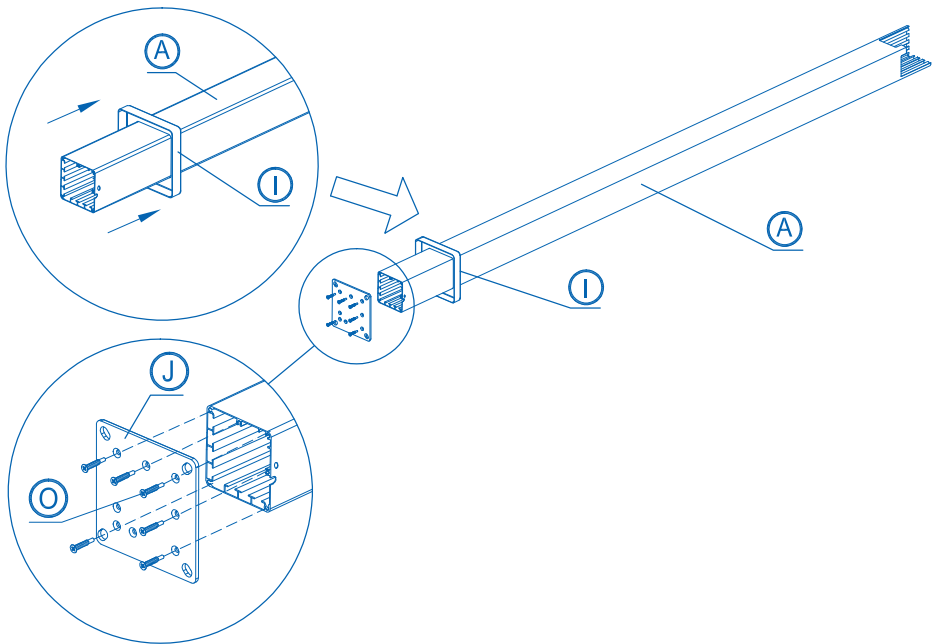

Figure 2.

# ASSEMBLY

## STEP 3

Lay two of the leg sections (A) on the ground as shown below. Take the (B1) rail and slide each end into position in the grooves along the top of the leg sections. Use large allen key (Y) to affix the four screws on each corner.

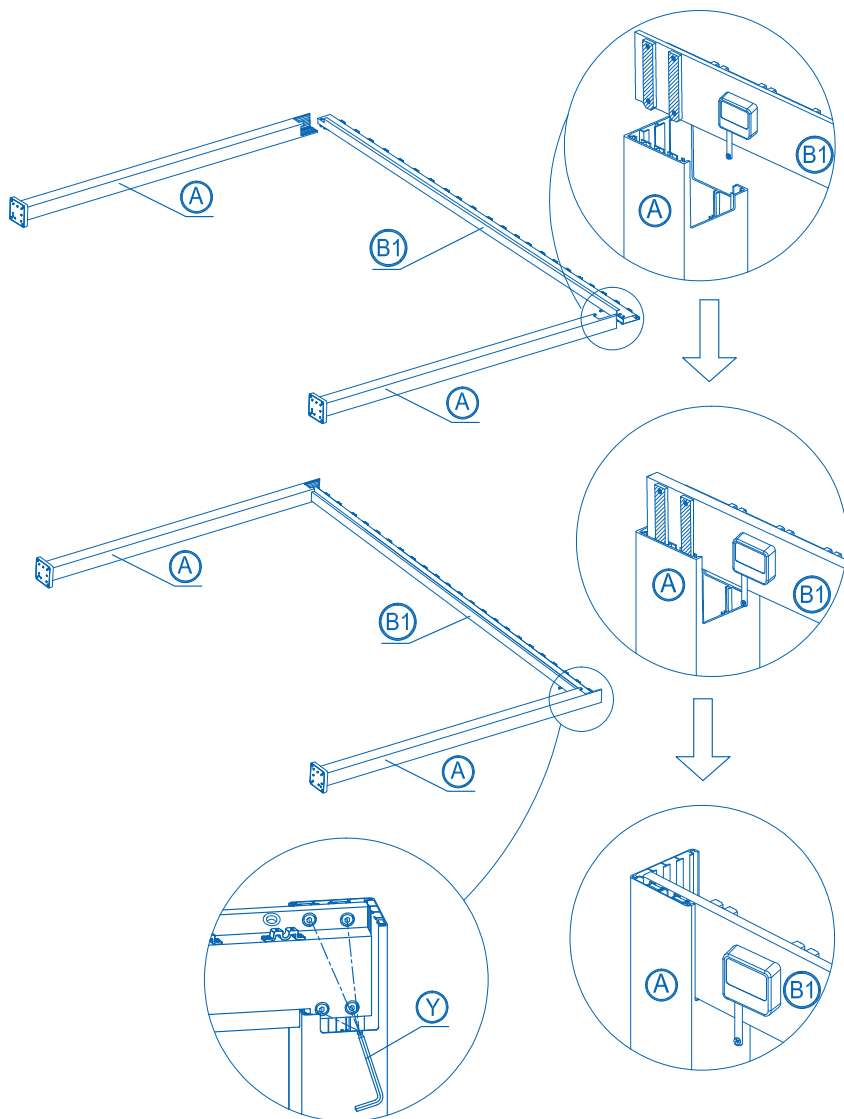

Figure 3.



## STEP 4

Lay down the other two leg sections (A) on the ground as shown. Take the (B2) rail and slide each end into position in the grooves along the top of the leg sections, just like the previous step. Use large allen key (Y) to affix the four screws on each corner.

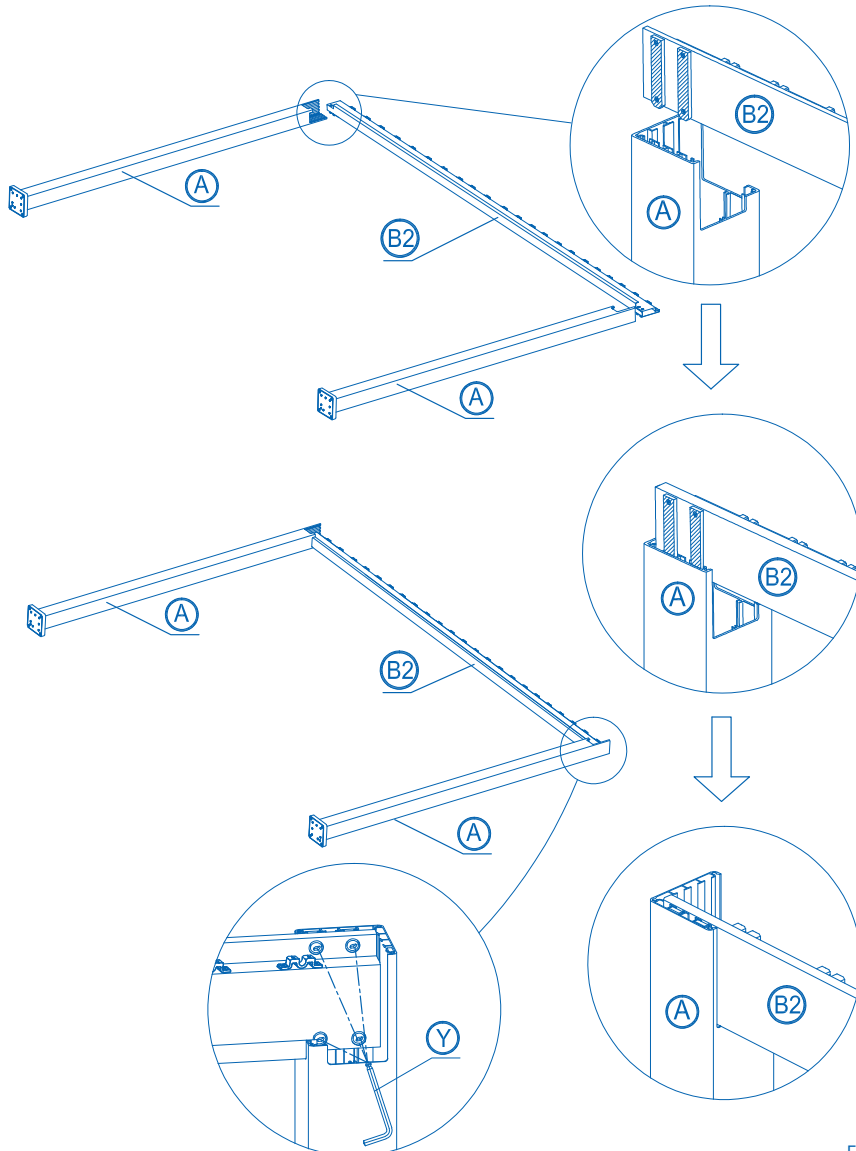

Figure 4.

## STEP 5

Working with at least one partner and ensuring everyone is wearing a hard hat, set up two ladders. Lift up one side wall (made up of two legs and a rail) and raise one end of the beam (C) above the opening on the leg section (A). Carefully slide the guides on the beam (C) down into the slots on the leg section (A). Use large allen key to drive in four more screws.

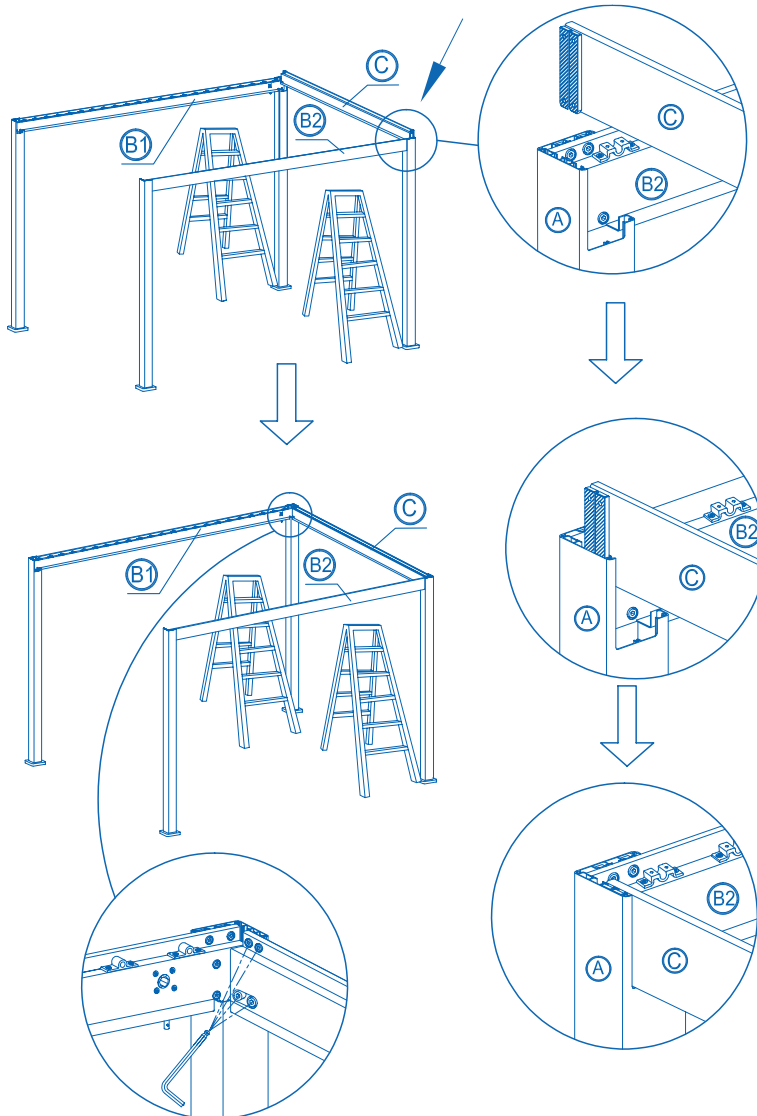

Figure 5.

## STEP 6

Move the ladders to the other side of the structure. Install the other beam (C) onto the open end, using the same method as in Step 5.

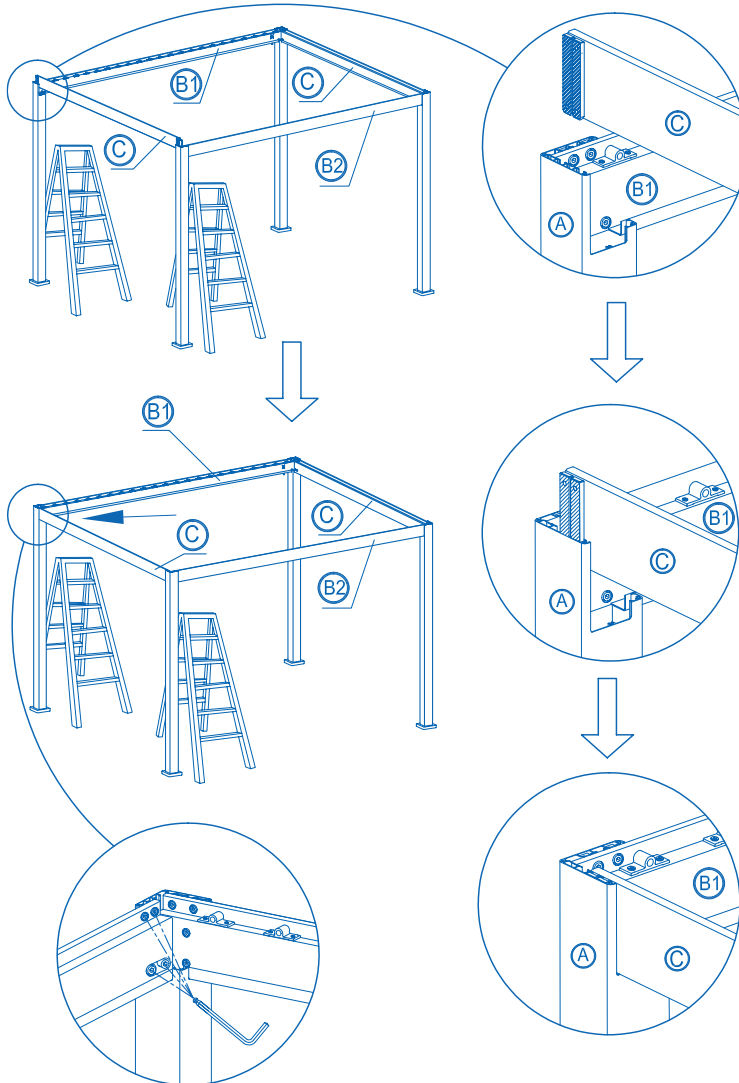

Figure 6.

## STEP 7

Find the corner below along the B1 rail with the crank pin hanging down. Remove the screw from the crank pin temporarily. Slide the crank mechanism (V) over the pin, lining up the holes. Drive the screw through both parts. Insert the hook of the crank handle (H) through the crank mechanism (V).

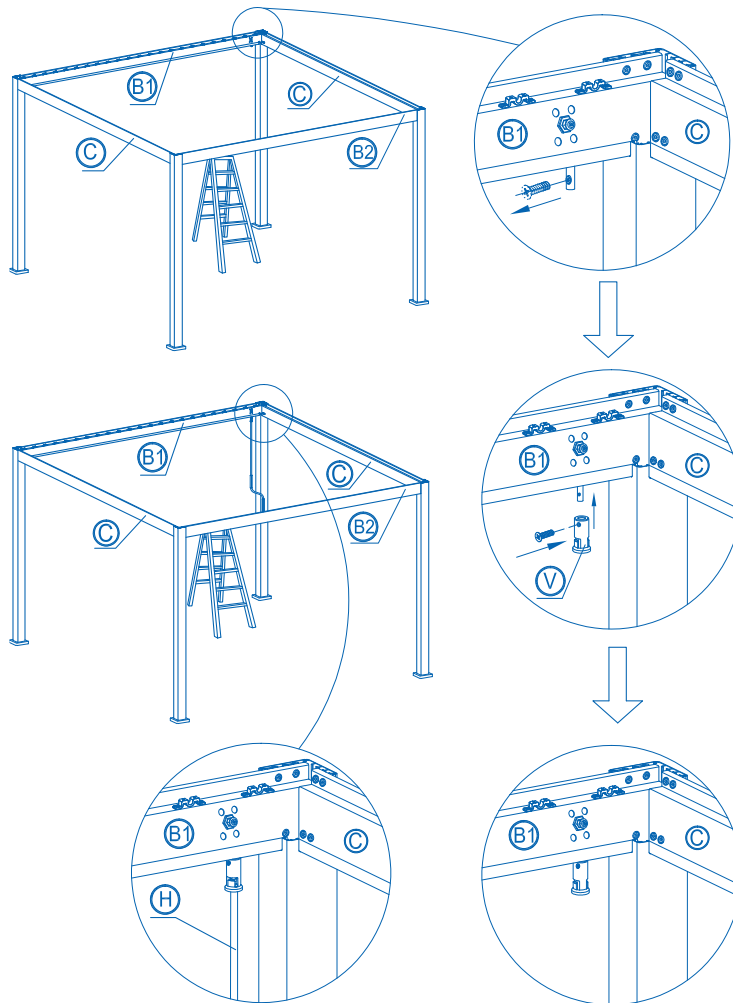

Figure 7.

## STEP 8

Take one of the louvres (D) aside and position as shown below, with the large opening facing up and in front of you. Take the louvre arm plate (L) and position it on the inside of the left end of the louvre. Use two of the 25mm screws (Q) to affix the controller to the louvre.

Find one of the louvre plates (K) and position it on the inside of the right end of the louvre. Screw the plate in place using two more of the 25mm screws.

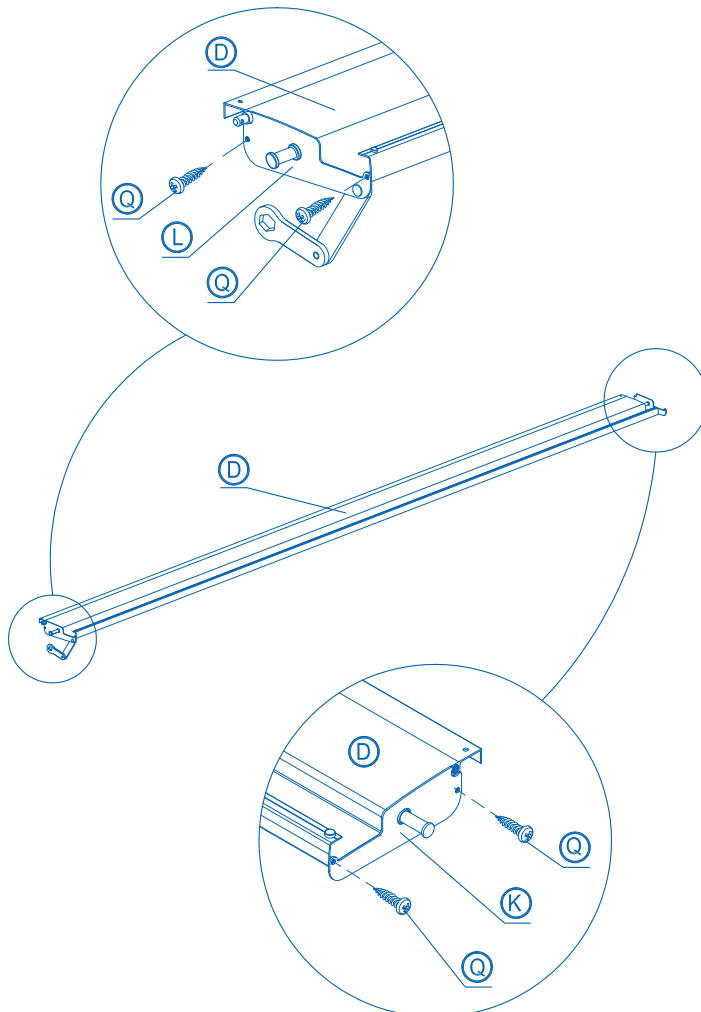

Figure 8.

## STEP 9

Remove the crank bolt from the (B) beam using the Allen key (X). Position the louvre at the top of the gazebo with the attached arm (L), lining up the louvre arm (L) with the crank socket on the (B) beam, just above the crank handle (second cradle position). Place the pin on the other end of the louvre in the second cradle position on top of the B2 beam.

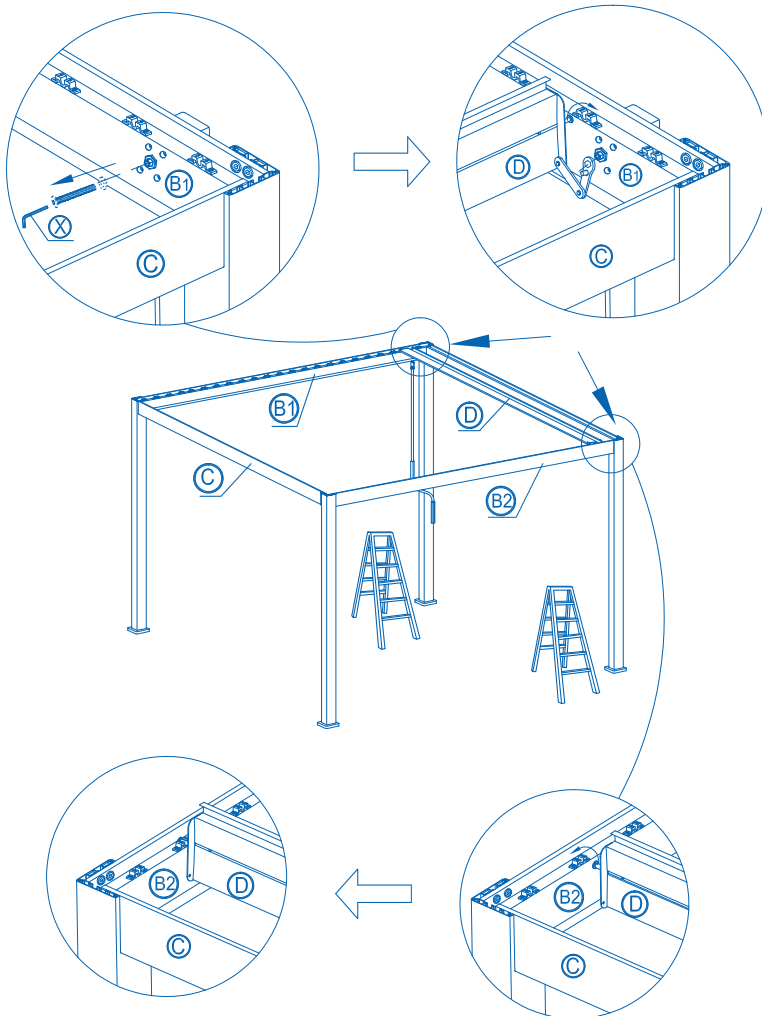

Figure 9.

## STEP 10

Ensure the louvre arm (L) is in the correct position (as per illustration).  
Re-insert the louvre bolt and tighten with the Allen key (X).

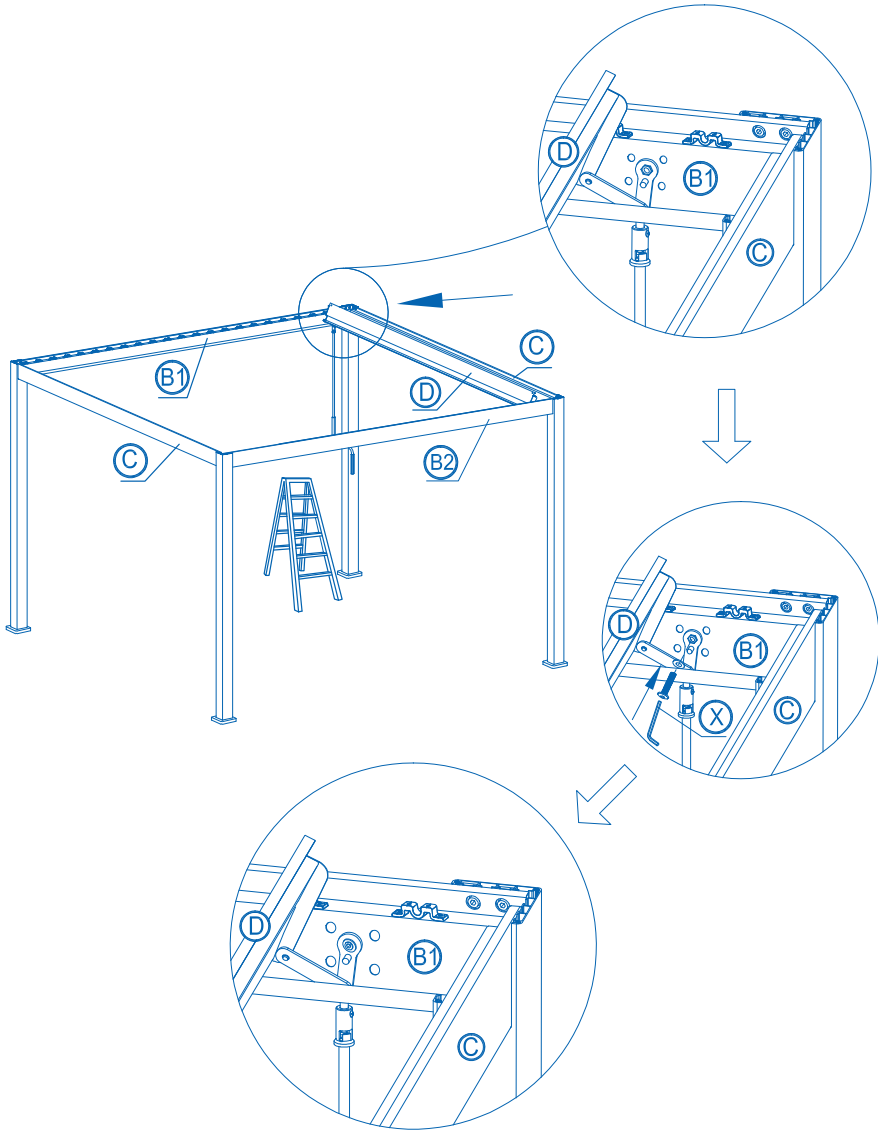

Figure 10.

## STEP 11

On the other side of the louvre, secure the louvre pin into the second position slot by placing a small cover (M) on top of the slot section, lining up the holes. Screw the cover in place using two M5 screws (P).

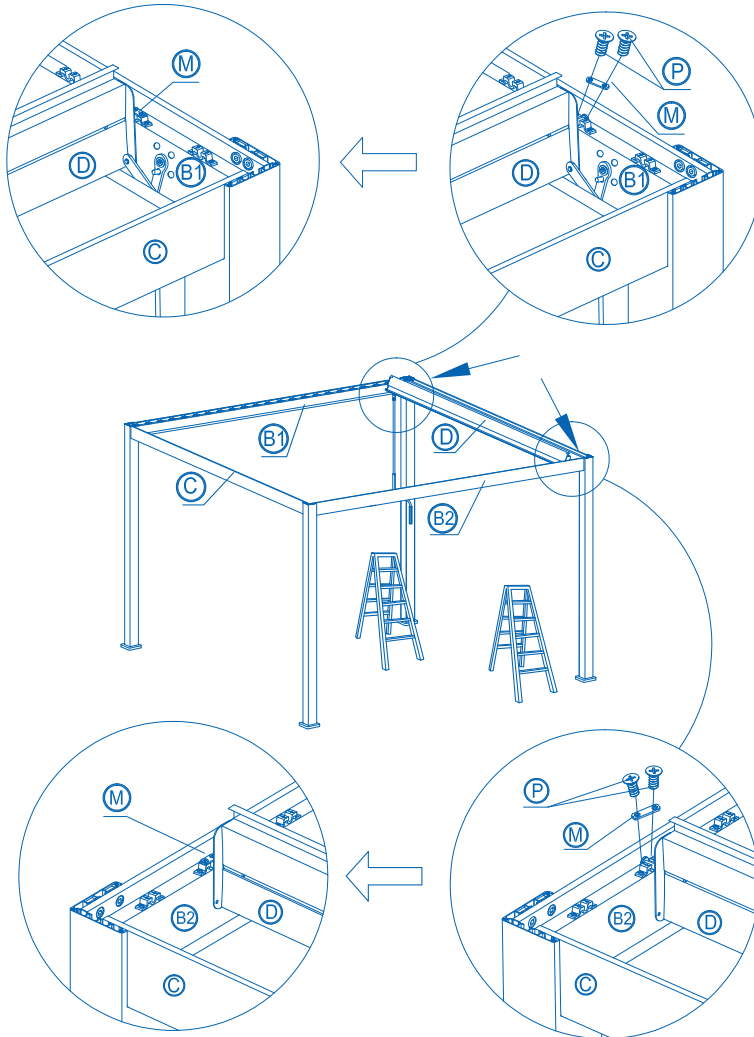

Figure 11.



## STEP 12

For each of the remaining 22 louvres, position a louvre plate (K) on the inside of each end. Affix each of the plates into place using two 25mm screws (Q).

×22 times

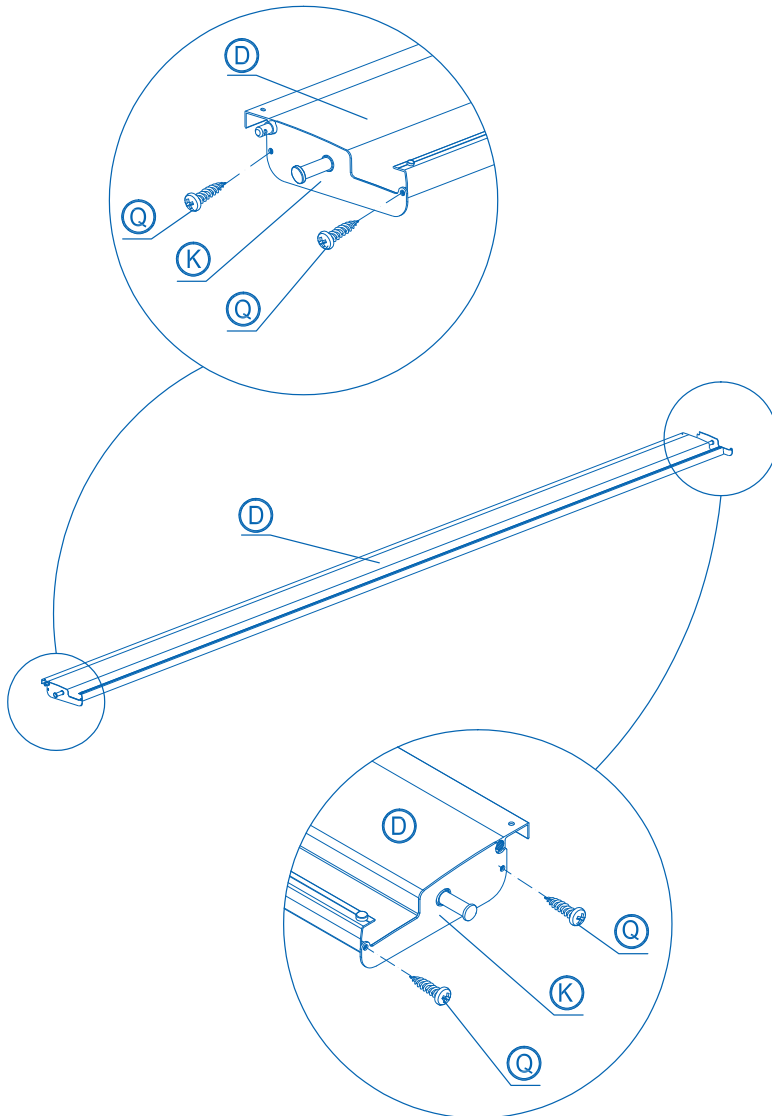

Figure 12.

## STEP 13

Install one of these louvres into the first position, next to the beam. Ensuring this louvre is in the same orientation as the one already installed, insert the pin on the crank handle end into the first hole position on the B1 rail. Place the pin on the other end of the louvre into the first position slot. Place a small cover (M) on top and screw down in place using two M5 screws (P).

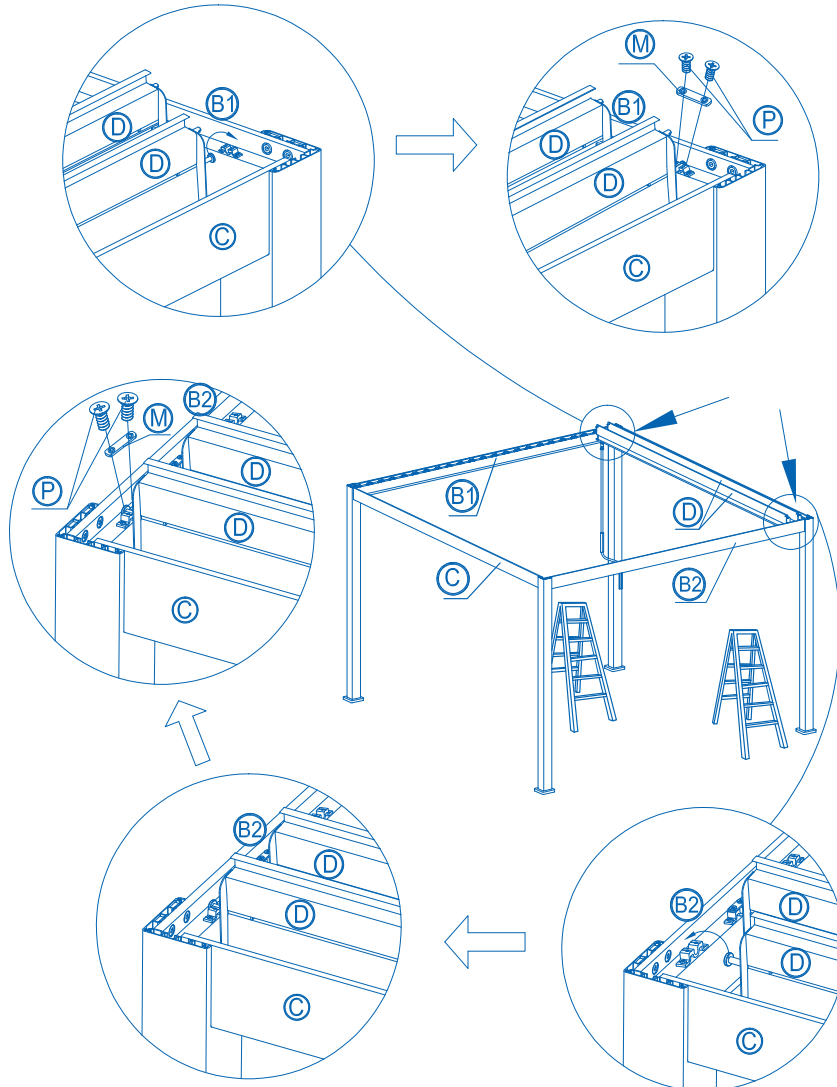

Figure 13.

## STEP 14

Carefully twist the crank handle to ensure the louvre already installed in the second position is rotating correctly (note, the louvre in the first position is designed to remain closed). Rotate the louvre and leave it open in a vertical position.

Install the remaining louvres in the same way as before. Ensure each louvre is in the same orientation, insert the pin on one end of the louvre into the hole on the B1 rail, place the other pin into the slot on the opposite end and screw down the small cover (M) with two M5 screws (P).

Adjust the driving louvre in a vertical position.

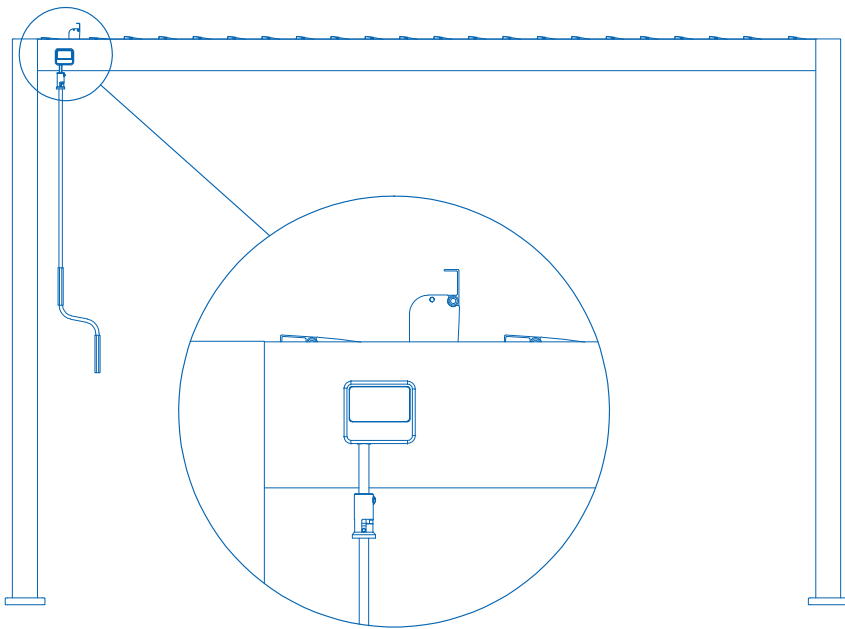

Figure 14.

## STEP 15

Once all louvres are correctly installed, take the louvre guide rail (G) and line up the holes with the free louvre pins on the crank handle side. Put the louvre guide rail over the pins as shown below. Push the straight section of a split pin (s) through the small hole of each pin protruding through the guide rail.

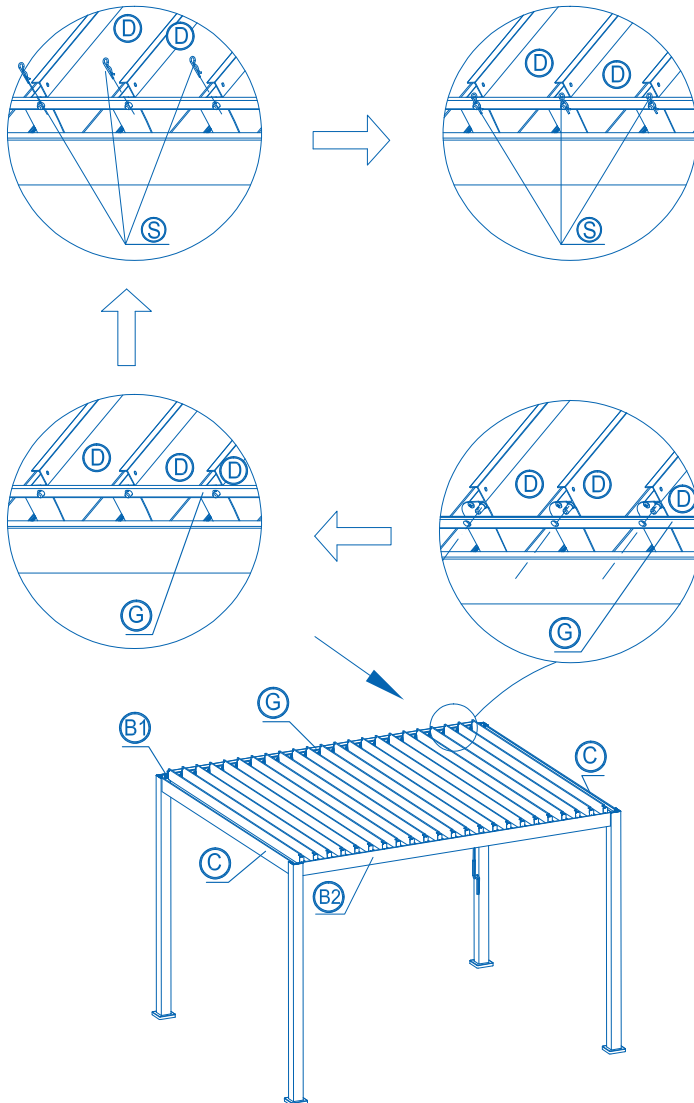

Figure 15.

## STEP 16

Position a right-angle plate (N) on top of one of the corners. Use three 19mm screws (R) to affix it into place. Repeat for the remaining corners.

## STEP 17

Secure the feet of the gazebo into the ground. For a hard surface such as concrete or tile, drill holes into the surface through the holes in the feet and install the supplied anchor bolts (W). For other surfaces, use another suitable fastener to secure the gazebo down.

x4 times

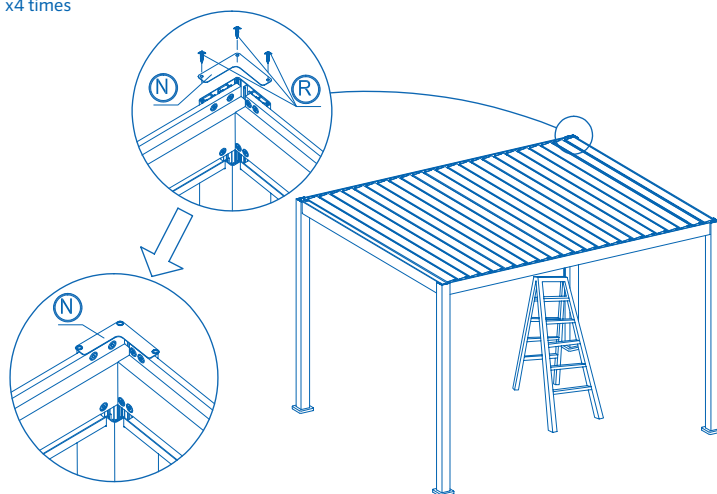

Figure 16.

x4 times

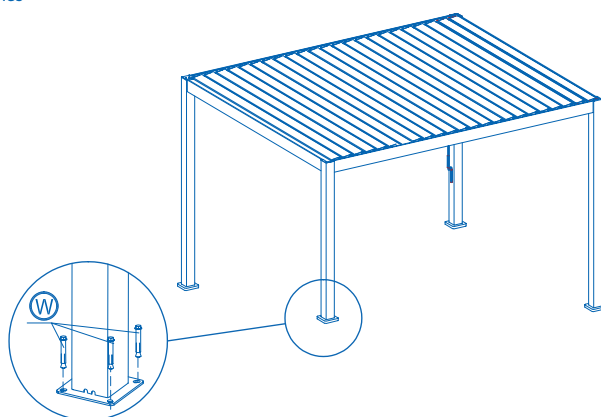

Figure 17.

**WARNING: Louvres must remain in the open position when not in use.**

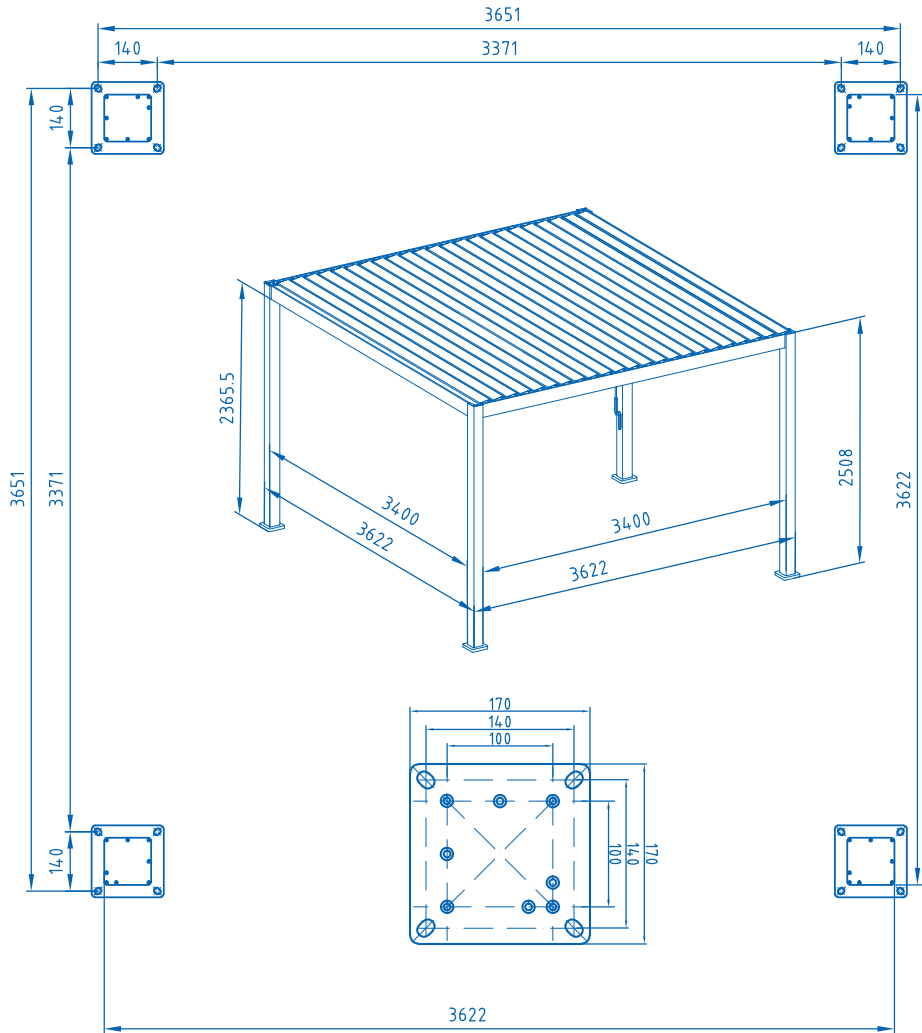

Figure 18.

## PRODUCT WARRANTY AND LIMITATION OF LIABILITY

Coolaroo products are manufacture by Gale Pacific Limited ACN 082 263 778 (Gale). Gale provides the following warranty in relation to Coolaroo products ("Product").

The benefits of this warranty are in addition to any rights and remedies imposed by Australian Consumer Law, NZ Consumer Guarantees Act 1993, and state and federal legislation that cannot be excluded. Nothing in this warranty is to be interpreted as excluding, restricting or modifying any applicable legislation to the supply of goods and services which cannot be excluded, restricted or modified.

### WARRANTY

Gale warrants that, subject to the exclusions and limitations below, all parts of the manufacture and assembly of the Product will be free from defects in materials and workmanship for a period of five (5) years for the frame from the date of purchase.

If a defect appears in the Product before the end of the warranty period and Gale finds the product to be defective in materials or workmanship, Gale will, in its sole discretion, either:

- a) replace or repair the Product or the defective part of the Product free of charge; or
- b) refund the purchase price of the Product.

Gale reserves the right to replace defective parts of the Product with parts and components of similar quality, grade and composition where an identical part or component is not available.

The warranty will not apply where:

- a) the Product has been altered or modified by someone other than Gale or its authorised agent;
- b) the alleged defect in the Product is within acceptable industry variances;
- c) Gale cannot establish any fault in the Product;
- d) the defect in the Product has arisen due to the customer's failure to install and use the Product in accordance with the instructions provided;
- e) the defect in the Product has arisen due to the customer's request to customise the Product;
- f) the Product has been subject to abnormal conditions, including environment, temperature, water, fire, humidity, pressure, stress or similar.

The warranty does not extend to:

- a) damage or defects caused by normal wear and tear,
- b) water or sun damage; or
- c) any other damage caused by the customer placing other equipment, furniture or material in close proximity to the Product.

Gale makes no express warranties or representations other than set out in this warranty.

The repair or replacement of the Product or part of the Product is the absolute limit of Gale's liability under this express warranty.

### WARRANTY CLAIMS

- 1) Upon purchasing the Product, the customer must register their warranty by completing the Coolaroo online warranty registration at [www.coolaroo.com](http://www.coolaroo.com). Alternatively, the customer can contact Coolaroo Customer Service on 1800 331 521 (AU) or 0800 555 171 (NZ) for assistance.
- 2) If a fault covered by warranty occurs, the customer must contact Gale using the contact details provided.
- 3) Any warranty claim must be accompanied by proof of purchase and details of the alleged defect.
- 4) The customer must bear the cost of the transport of the Product to and from Gale or the authorised agent to make the warranty claim, and all insurance of the Product.

### AUSTRALIAN CONSUMER LAW

Nothing in this agreement is intended to have the effect of contracting out of any applicable provisions of the Competition and Consumer Act 2010 or the Fair Trading Acts in each of the States and Territories of Australia, except to the extent permitted by those Acts where applicable.

This warranty is not transferable, and applies only to the initial purchaser of the installed Product.

In addition to the above warranty, Australian Consumer law and other state and territory legislation may imply warranties or conditions or impose liability on Gale in relation to the Product or its supply which cannot, or can only to a limited implied warranties or conditions and such liability, and for the warranty described above:

- a) all warranties and conditions (whether express or implied, statutory or otherwise) relating to the Product or its supply are expressly excluded; and
- b) Gale will not be liable for any loss or damage suffered by any person (including the purchaser of the Product) in any way relating to or arising from the Product or its use (including loss or damage arising from the negligence of, or contributed to by, Gale).

If liability for breach by Gale of a warranty or condition or any other liability imposed on Gale by legislation which cannot be excluded may be limited, Gale's liability is limited to the extent permitted by law, and if liability may be limited in any one of a number of ways, Gale's liability is limited in any one of the permitted ways chosen by Gale in its absolute discretion.

The Purchaser acknowledges that the Purchaser does not rely on the skill or judgment of Gale as to whether or not the Products are fit for any particular purpose.

The Purchaser indemnifies Gale from every liability, loss, damage, cost or expense directly or indirectly incurred or suffered by Gale caused by or contributed to by the Purchaser's failure to:

- 1) adequately provide or display safety markings or safety information on or with the Products;
- 2) comply with any law about the Products or their use;
- 3) take any reasonable precaution to bring to the attention of any potential users of the Products any dangers associated with Products;
- 4) any negligence or breach of duty by the Purchaser or any breach by the Purchaser of these terms.



## THANK YOU FOR PURCHASING A COOLAROO PRODUCT

Exposure to ultraviolet (UV) radiation from the sun is the major cause of skin cancer. In some countries the UV radiation is strong enough to cause sunburn in just 11 minutes on a fine summers day. To prevent sun damage we recommend following the Sun Smart steps: slip on clothing, slop on sunscreen, slap on a hat, slide on sunglasses and seek shade.

To register your product go to [coolaroo.com.au](http://coolaroo.com.au). The product code can be found printed above the barcode on the product packaging, alternatively you can find it on the relevant [coolaroo.com.au](http://coolaroo.com.au) product page.

**ATTENTION:** The schematics in this manual are for assembly and operation illustration only. They may differ from the gazebos actual appearance.

[coolaroo.com](http://coolaroo.com)

### **WARNING**

When assembling and using this product, safety precautions should always be followed to reduce the risk of personal injury and damage to equipment. Please read all instructions before assembly and use.

At least two or more people are recommended for safe assembly.

Keep all children and pets away from assembly area.

Check all nuts and bolts for tightness before and during usage.

Non permanent structure. Do not use in extreme weather conditions including heavy rain or high winds.

Do not leave the gazebo unattended. Louvres must remain in the open position when not in use.

Do not place the product near an open flame; or too close to any heat source.

For help with product assembly or for any other questions you may have, contact our Customer Service Department.

Item Code: 503093

Australia toll free: 1800 331 521  
New Zealand toll free: 0800 555 171  
United States Ph: +1 407 772 7900  
Middle East Ph: +971 4 881 7114  
China Ph: +86 574 5626 8888



Gale Pacific Limited  
145 Woodlands Drive, Braeside,  
Victoria 3195 Australia

Coolaroo is a registered trademark  
of Gale Pacific Limited

**MADE IN CHINA**

