



# CANTILEVER UMBRELLA

***MACKAY***

**ASSEMBLY GUIDE AND  
OPERATING INSTRUCTIONS**

## ⚠ WARNING

When assembling and using this product, safety precautions should always be followed to reduce the risk of personal injury and damage to equipment.

Please read all instructions before assembly and use.

Two or more people are recommended for safe assembly.

Keep all children and pets away from assembly area.

Install on level ground.

Check all nuts and bolts for tightness before use and regularly during use.

This is a non-permanent structure, do not use in extreme weather conditions including heavy rain or high winds.

Do not leave the umbrella unattended when open.

Do not place the product near an open flame or too close to any heat source such as heaters or BBQ's.

The diagrams in this manual are for assembly and operation only.  
Illustrations may differ from the umbrella's actual appearance.

## CARE AND MAINTENANCE

When not in use, close the umbrella, fasten canopy and store in a dry place. If the canopy is wet, allow to dry naturally when opened up before storing.

If necessary, clean the fabric with a hose.

DO NOT use umbrella over or near harsh chemicals or open flames including but not limited to chlorine, grills, barbecues and fire pits.

Components subject to turning and sliding can be treated with a non-staining lubricant spray (silicon-based).



## ASSEMBLY GUIDE

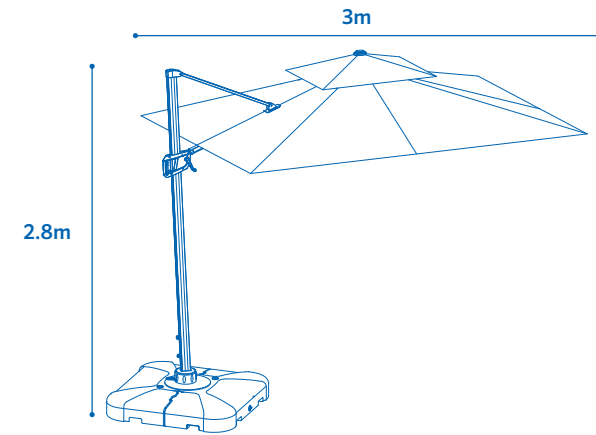

### STEP 1

Take all of the parts out of box 1 and 2 to ensure they are all present before starting construction.

#### Box 1

- a) Umbrella frame and cover
- b) Lower pole
- c) 360 degree swivel
- d) Plastic cover
- e) Screws x4 (M8x25)
- f) Screws x4 (M8x14)
- g) Washers x8
- h) Crank handle
- i) Allen key
- j) Locking screw x2



#### Box 2

- k) Fillable base

## STEP 2

Attach the swivel base (c) to the water base (k) using screws (e) and washers (g). Use allen key (l) to tighten.

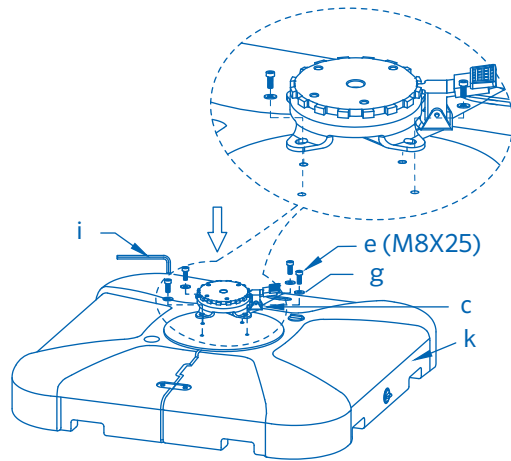

## STEP 3

Attach the lower pole (b) to the swivel base using screws (f) and washers (g). Use allen key (l) to tighten.

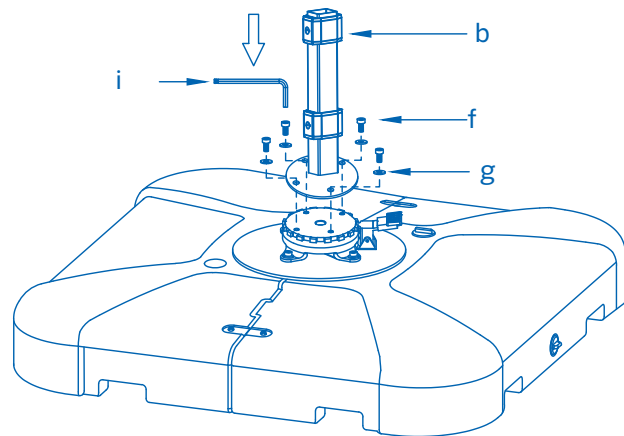

## STEP 4

Fill base (k) with water or sand. Place plastic cover (d) over lower pole (b).

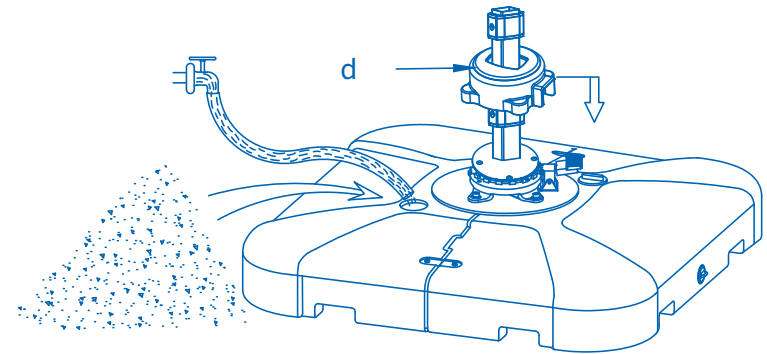

## STEP 5

Place umbrella frame and cover (a) over lower pole (b) so it slides inside the plastic cover (d).

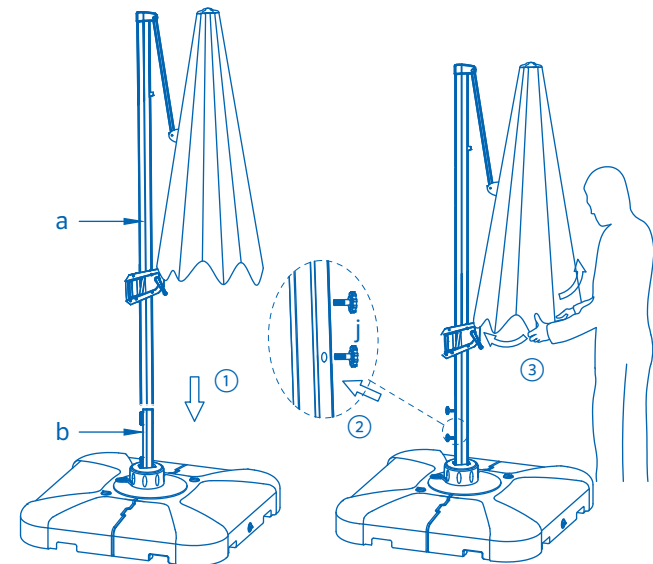

## STEP 6 - TO OPERATE

Ensure ribs are free to move by fluffing open the canopy. Pull the trigger on the easy glide handle and lift until it locks into the lowest position. Open the umbrella by inserting and winding the crank handle (h).

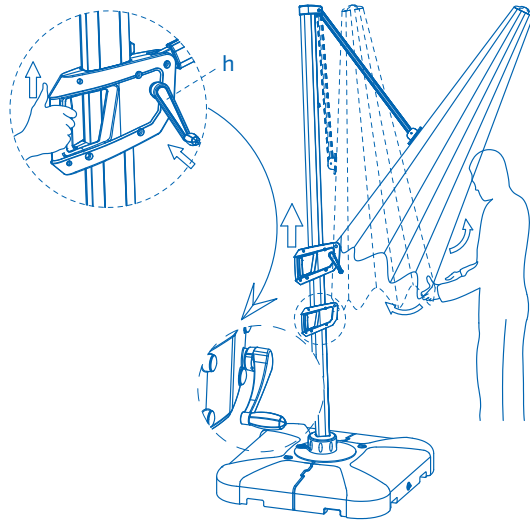

## STEP 7

To open the canopy, wind the crank handle (h) in a clockwise direction. To close the canopy, wind the crank handle in an anti clockwise direction.

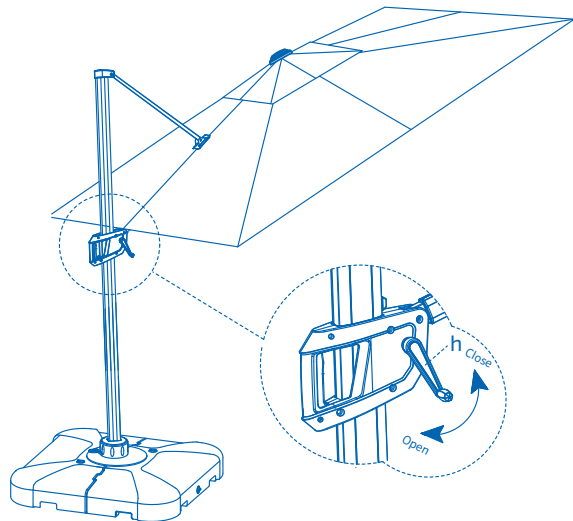

## STEP 8 - ROTATING THE CANOPY

Use the foot pedal on the swivel base (c) to rotate the canopy in a clockwise, or anti clockwise direction. The canopy can be rotated 360 degrees in either direction.

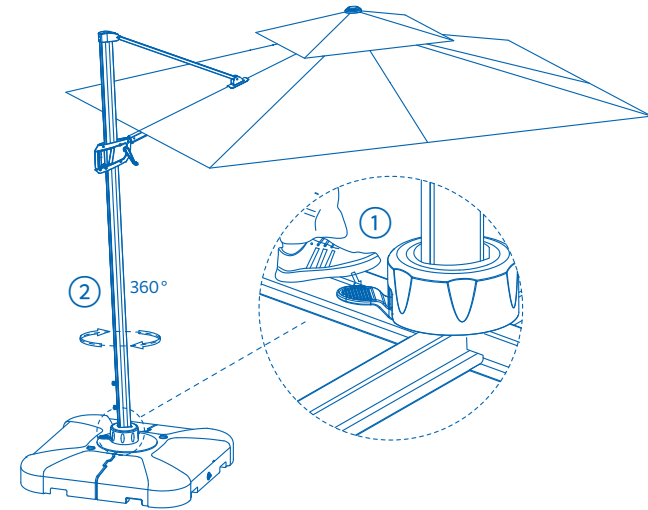

## STEP 9 - CLOSING THE UMBRELLA

To close the umbrella, wind the canopy down with the crank handle in the anti clockwise direction. Move the easy glide handle to the bottom position and wrap the Velcro® straps around the canopy.

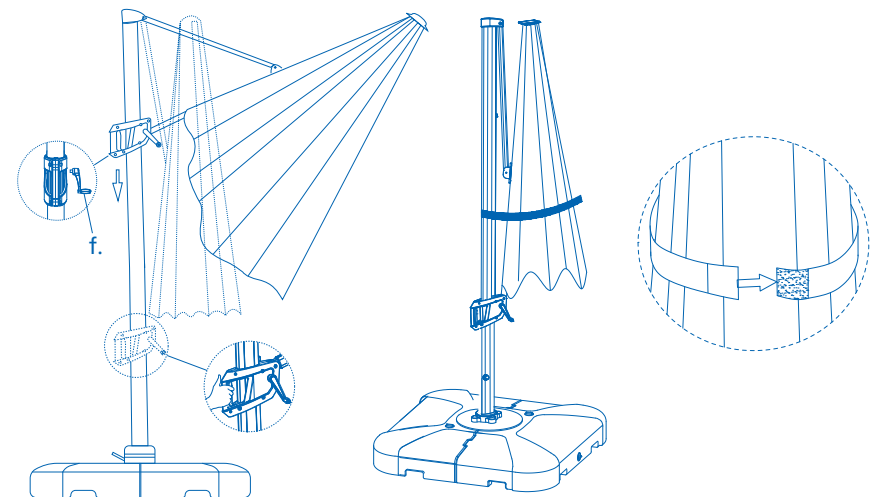

## STEP 10 - INSTALL THE COVER

With the cover open, use the stay poles to position the cover over the closed umbrella. Use the Velcro® to close and secure the cover over the umbrella.

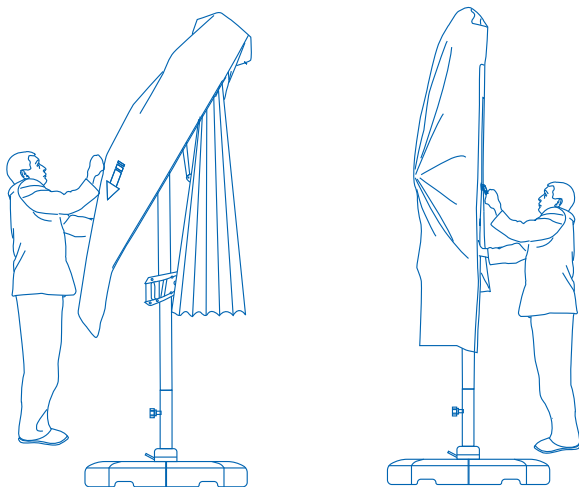

Ensure canopy is closed when not in use. Close in windy conditions or when a storm approaches.  
Never allow the umbrella to flap in the wind; this could damage the canopy.

## PRODUCT 2 AND 5 YEAR WARRANTY AND LIMITATION OF LIABILITY

Coolaroo products are manufacture by Gale Pacific Limited ACN 082 263 778 (Gale). Gale provides the following warranty in relation to Coolaroo products ("Product").

The benefits of this warranty are in addition to any rights and remedies imposed by Australian Consumer Law, NZ Consumer Guarantees Act 1993, and state and federal legislation that cannot be excluded. Nothing in this warranty is to be interpreted as excluding, restricting or modifying any applicable legislation to the supply of goods and services which cannot be excluded, restricted or modified.

### WARRANTY

Gale warrants that, subject to the exclusions and limitations below, all parts of the manufacture and assembly of the Product will be free from defects in materials and workmanship, for a period of 2 years for the frame and 5 years for the canopy, from the date of purchase.

If a defect appears in the Product before the end of the warranty period and Gale finds the product to be defective in materials or workmanship, Gale will, in its sole discretion, either:

- replace or repair the Product or the defective part of the Product free of charge; or
- refund the purchase price of the Product.

Gale reserves the right to replace defective parts of the Product with parts and components of similar quality, grade and composition where an identical part or component is not available.

The warranty will not apply where:

- the Product has been altered or modified by someone other than Gale or its authorised agent;
- the alleged defect in the Product is within acceptable industry variances;
- Gale cannot establish any fault in the Product;
- the defect in the Product has arisen due to the customer's failure to install and use the Product in accordance with the instructions provided;
- the defect in the Product has arisen due to the customer's request to customise the Product;
- the Product has been subject to abnormal conditions, including environment, temperature, water, fire, humidity, pressure, stress or similar.

The warranty does not extend to:

- damage or defects caused by normal wear and tear,
- water or sun damage; or
- any other damage caused by the customer placing other equipment, furniture or material in close proximity to the Product.

Gale makes no express warranties or representations other than set out in this warranty.

The repair or replacement of the Product or part of the Product is the absolute limit of Gale's liability under this express warranty.

## WARRANTY CLAIMS

- Upon purchasing the Product, the customer must register their warranty by completing the Coolaroo online warranty registration at [www.coolaroo.com](http://www.coolaroo.com). Alternatively, the customer can contact Coolaroo Customer Service on 1800 331 521 (AU) or 0800 555 171 (NZ) for assistance.
- If a fault covered by warranty occurs, the customer must contact Gale using the contact details provided.
- Any warranty claim must be accompanied by proof of purchase and details of the alleged defect.
- The customer must bear the cost of the transport of the Product to and from Gale or the authorised agent to make the warranty claim, and all insurance of the Product.

## AUSTRALIAN CONSUMER LAW

Nothing in this agreement is intended to have the effect of contracting out of any applicable provisions of the Competition and Consumer Act 2010 or the Fair Trading Acts in each of the States and Territories of Australia, except to the extent permitted by those Acts where applicable.

This warranty is not transferable, and applies only to the initial purchaser of the installed Product.

In addition to the above warranty, Australian Consumer law and other state and territory legislation may imply warranties or conditions or impose liability on Gale in relation to the Product or its supply which cannot, or can only to a limited implied warranties or conditions and such liability, and for the warranty described above:

- all warranties and conditions (whether express or implied, statutory or otherwise) relating to the Product or its supply are expressly excluded; and
- Gale will not be liable for any loss or damage suffered by any person (including the purchaser of the Product) in any way relating to or arising from the Product or its use (including loss or damage arising from the negligence of, or contributed to by, Gale).

If liability for breach by Gale of a warranty or condition or any other liability imposed on Gale by legislation which cannot be excluded may be limited, Gale's liability is limited to the extent permitted by law, and if liability may be limited in any one of a number of ways, Gale's liability is limited in any one of the permitted ways chosen by Gale in its absolute discretion.

The Purchaser acknowledges that the Purchaser does not rely on the skill or judgment of Gale as to whether or not the Products are fit for any particular purpose.

The Purchaser indemnifies Gale from every liability, loss, damage, cost or expense directly or indirectly incurred or suffered by Gale caused by or contributed to by the Purchaser's failure to:

- adequately provide or display safety markings or safety information on or with the Products;
- comply with any law about the Products or their use;
- take any reasonable precaution to bring to the attention of any potential users of the Products any dangers associated with Products;
- any negligence or breach of duty by the Purchaser or any breach by the Purchaser of these terms.



**THANK YOU**  
**FOR PURCHASING A**  
**COOLAROO PRODUCT**

While this umbrella will go a long way in providing protection from the sun, you should always apply all of the Sun Smart tips for optimal protection from UV rays. To prevent sun damage we recommend following the Sun Smart steps: slip on clothing, slop on sunscreen, slap on a hat, slide on sunglasses and seek shade under your premium Coolaroo umbrella.

To register your product, go to [coolaroo.com](http://coolaroo.com). The product code can be found printed above the barcode on the product packaging, alternatively you can find it on the relevant [coolaroo.com](http://coolaroo.com) product page.

[coolaroo.com](http://coolaroo.com)

For help with product assembly or for any other questions you may have, contact our Customer Service Department.

Australia toll free: 1800 331 521

New Zealand toll free: 0800 555 171

Item Code: 506520



Gale Pacific Limited  
145 Woodlands Drive, Braeside,  
Victoria 3195 Australia

Coolaroo and Xceltex are registered  
trademarks of Gale Pacific Limited

Made in China