

PARTS			
PART	DESCRIPTION	PART NO.	QTY
A	LEFT SIDE ASSEMBLY	SA-00359	1
B	RIGHT SIDE ASSEMBLY	SA-00360	1
C	GUSSET BRACE	PRT-00366	2
D	UNDER BRACE	PRT-00364	2
E	SPREADER	PRT-00365	1
F	TABLE TOP ASSEMBLY	SA-00202	1
G	SEAT ASSEMBLY	SA-00201	2

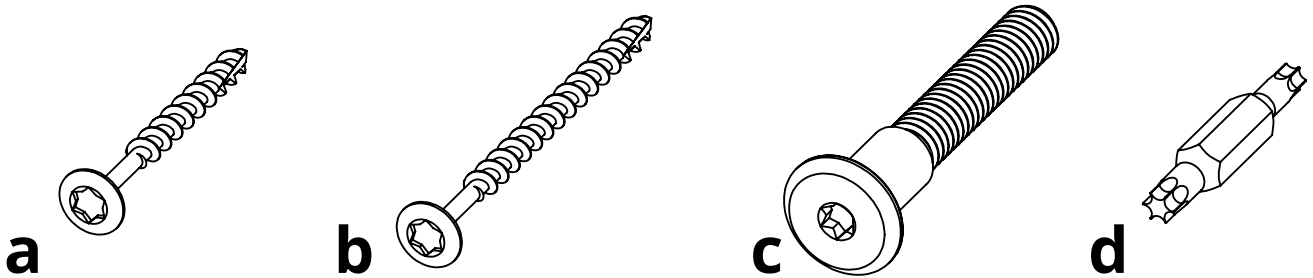

HARDWARE			
PART	DESCRIPTION	PART NO.	QTY
a	#8 X 1-3/4" TORX SCREW	H-0000-S8175	28
b1	#8 X 2-1/2" TORX SCREW-FRAME COLOR	H-0000-S825	8
b2	#8 X 2-1/2" TORX SCREW-TOP COLOR	H-0000-S825	16
c	5/16" X 2-1/8" CHAIR BOLT	H-0000-CB516218	8
d	T20 & T25 TORX BIT	H-0000-CTD	1

**Suggested Tools:** Drill, Plastic Mallet

# Please read entire instructions before beginning

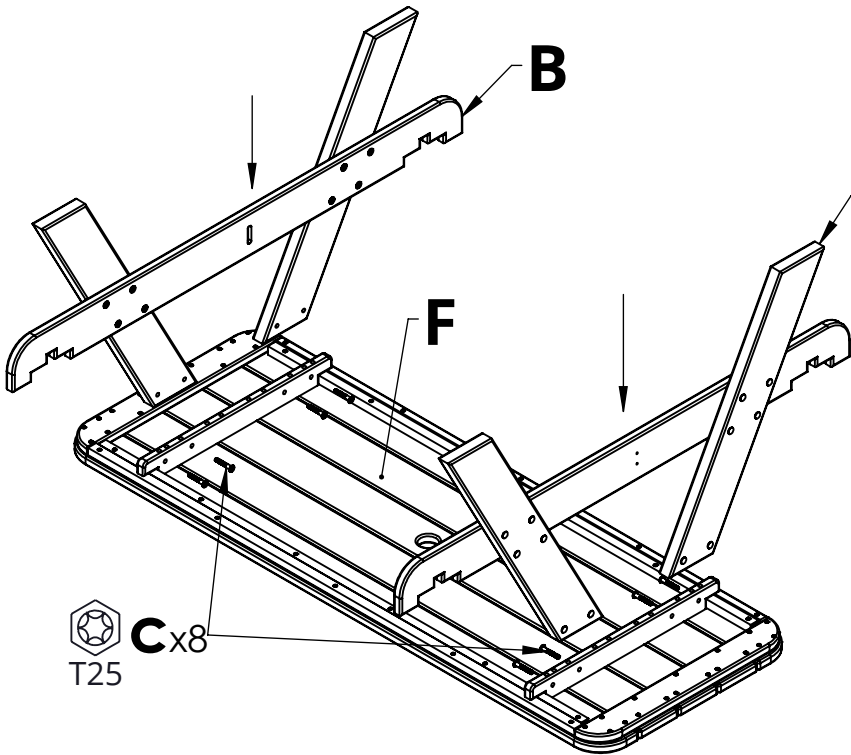

**1.** Lay Part F upside down and fasten Parts A & B with Part F using (8) of hardware c, four per side.

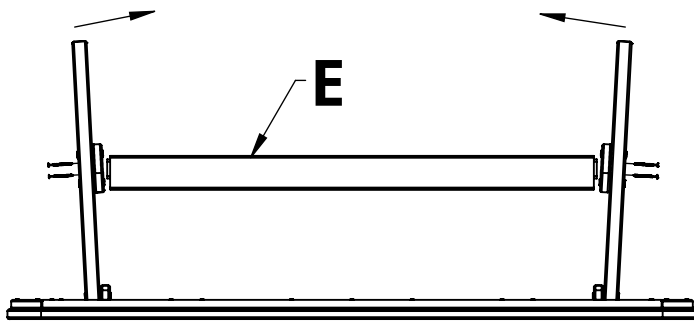

**2.** Flex Parts A & B to place and connect Part E

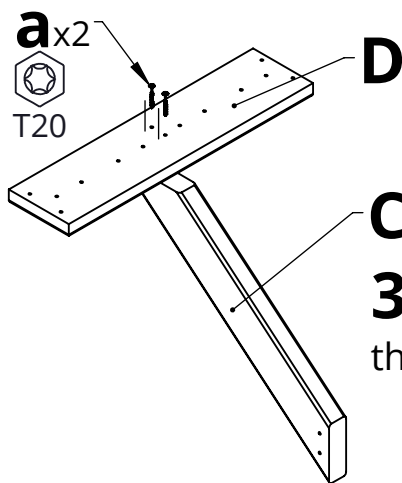
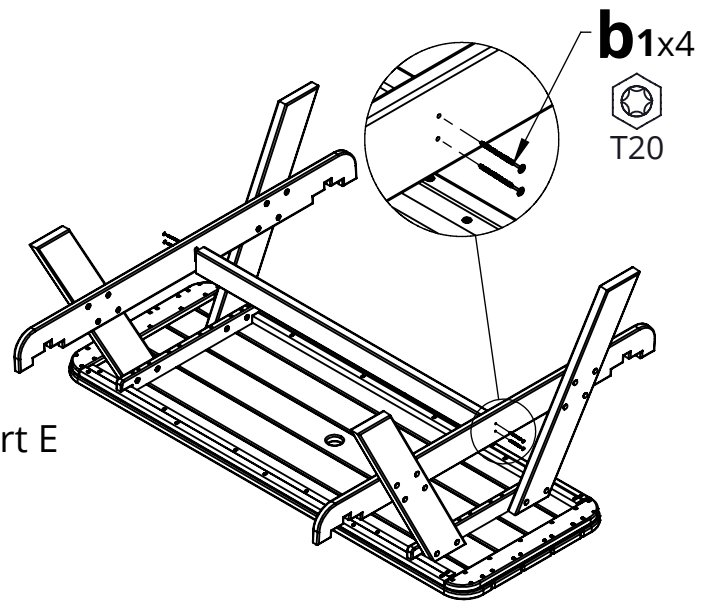

**3.** Attach Part D to Part C as shown, repeat this step to create two identical assemblies

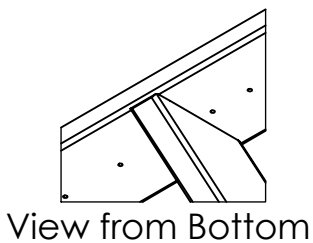

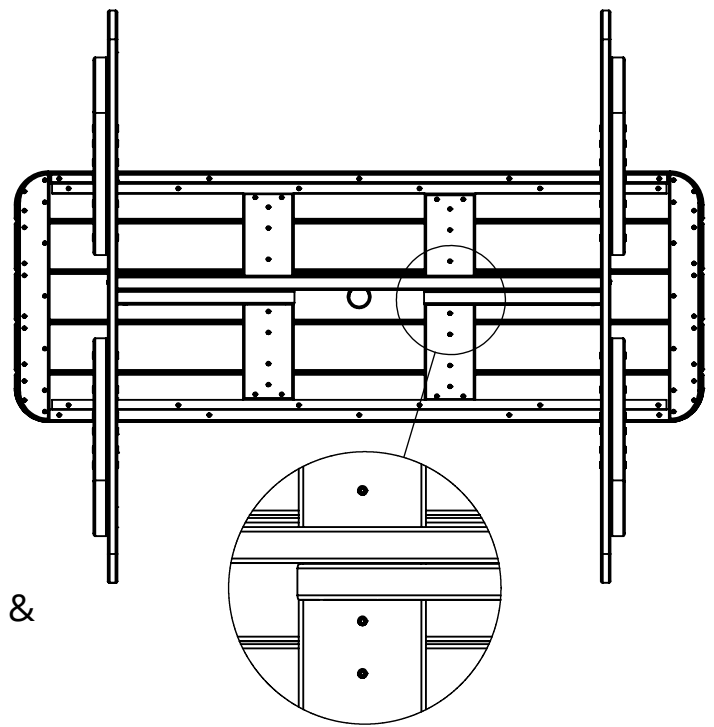
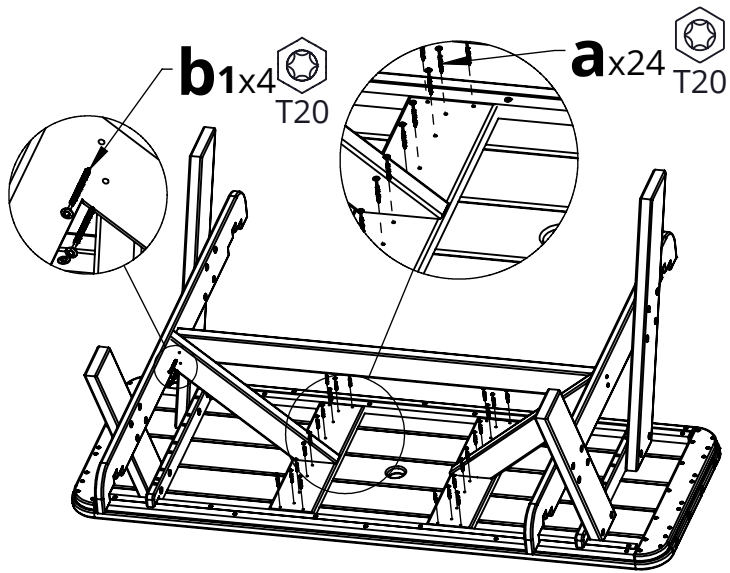

**4.** Place the previous assemblies as shown & connect them to Parts F & E

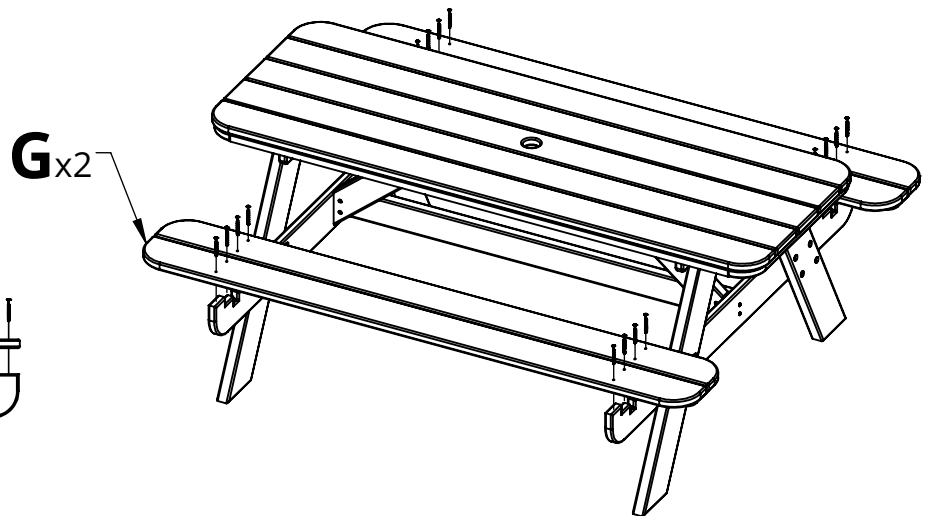
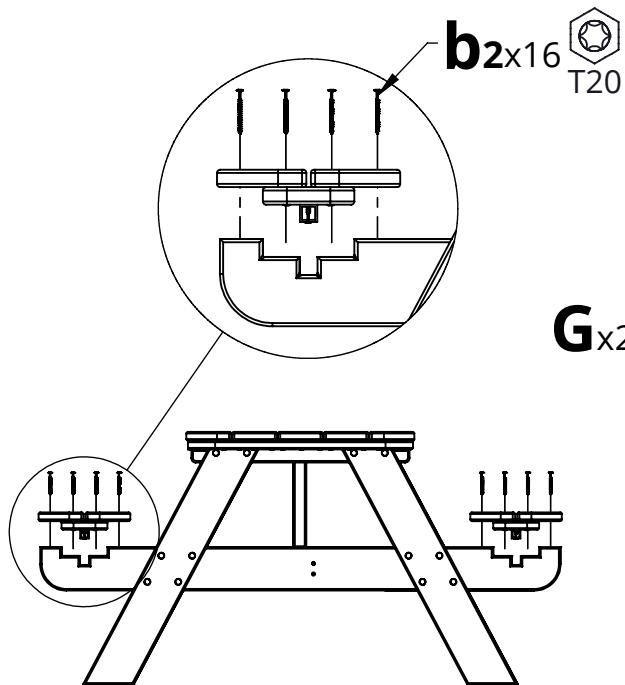

**5.** Rotate the assembly as shown & connect Parts G