

PARTS			
PART	DESCRIPTION	PART NO.	QTY
A	TABLE TOP ASSEMBLY	SA-00482	1
B	LEG	PRT-00982	4
C	FOOT	PRT-00983	2

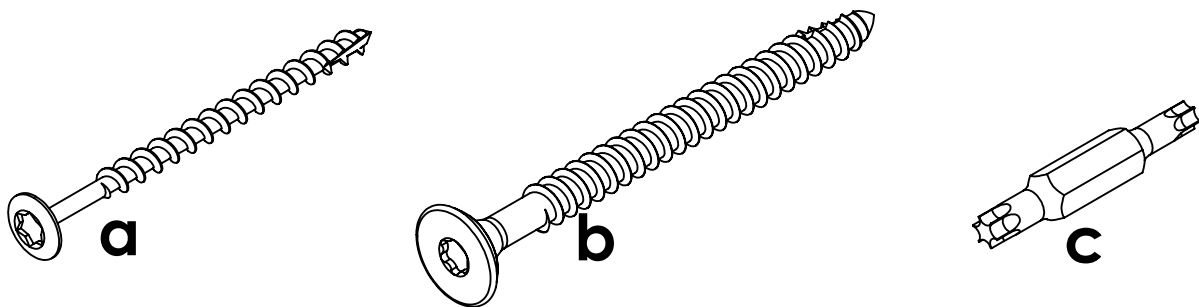

SA-00377 HARDWARE PACK			
PART	DESCRIPTION	PART NO.	QTY
a	#8 x 2-1/2" TORX SCREW	H-0000-S825	12
b	1/4"-10 x 3" LAG	H-0000-S103	16
c	T20 & T25 TORX BIT	H-0000-CTD	1

Suggested Tools: Drill, Mallet

Please read entire instruction before beginning

1. Pre-assemble the two leg assemblies by fastening (2) of part **B** to (1) of part **C** using hardware **a**.

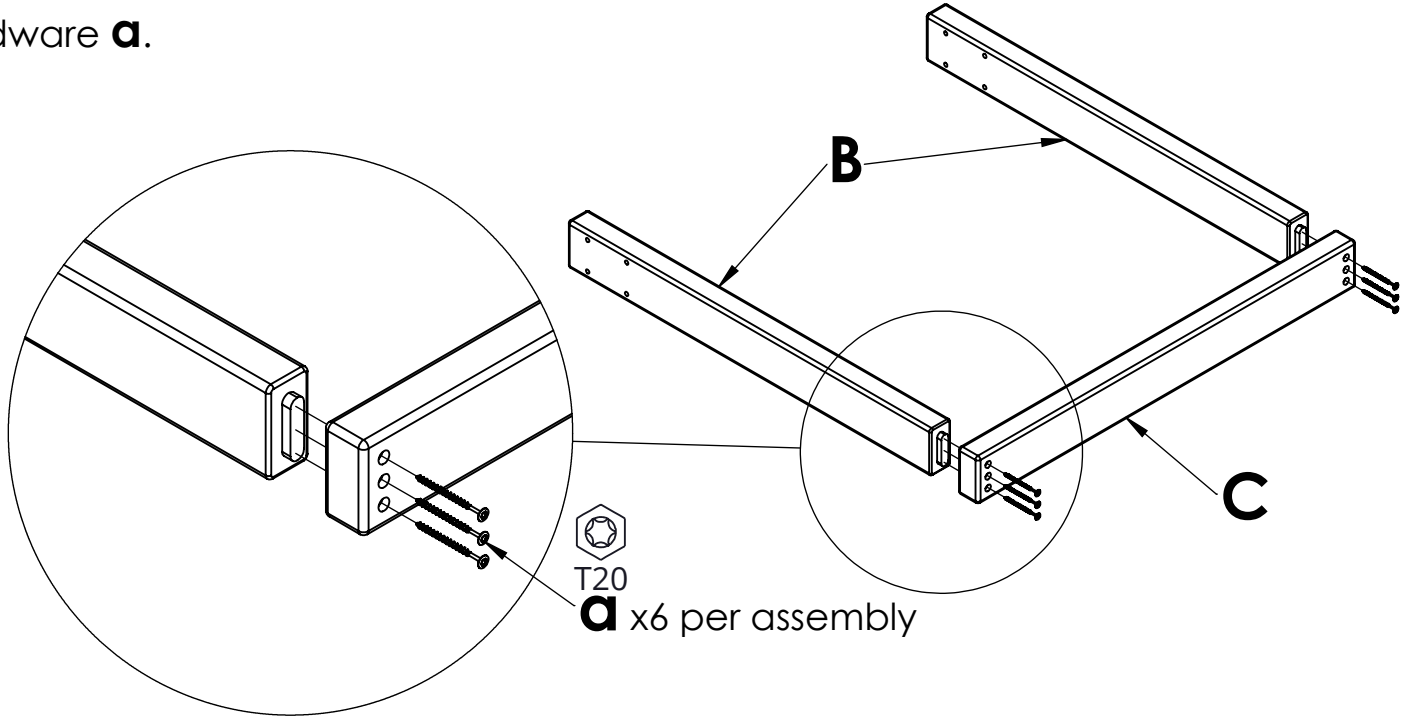

2. With the Table Top **A** laying on a non-marring surface, push the leg assemblies from step one down over the ends of the short table supports until they rest against the bottom of the table top. Fasten the leg assemblies using hardware **b**, (4) per leg. (2) screws should go into each short support. With help, turn the assembly onto its feet.

