

breezesta™

42"x 42" SQUARE ENDED BAR TABLE
BH-0918

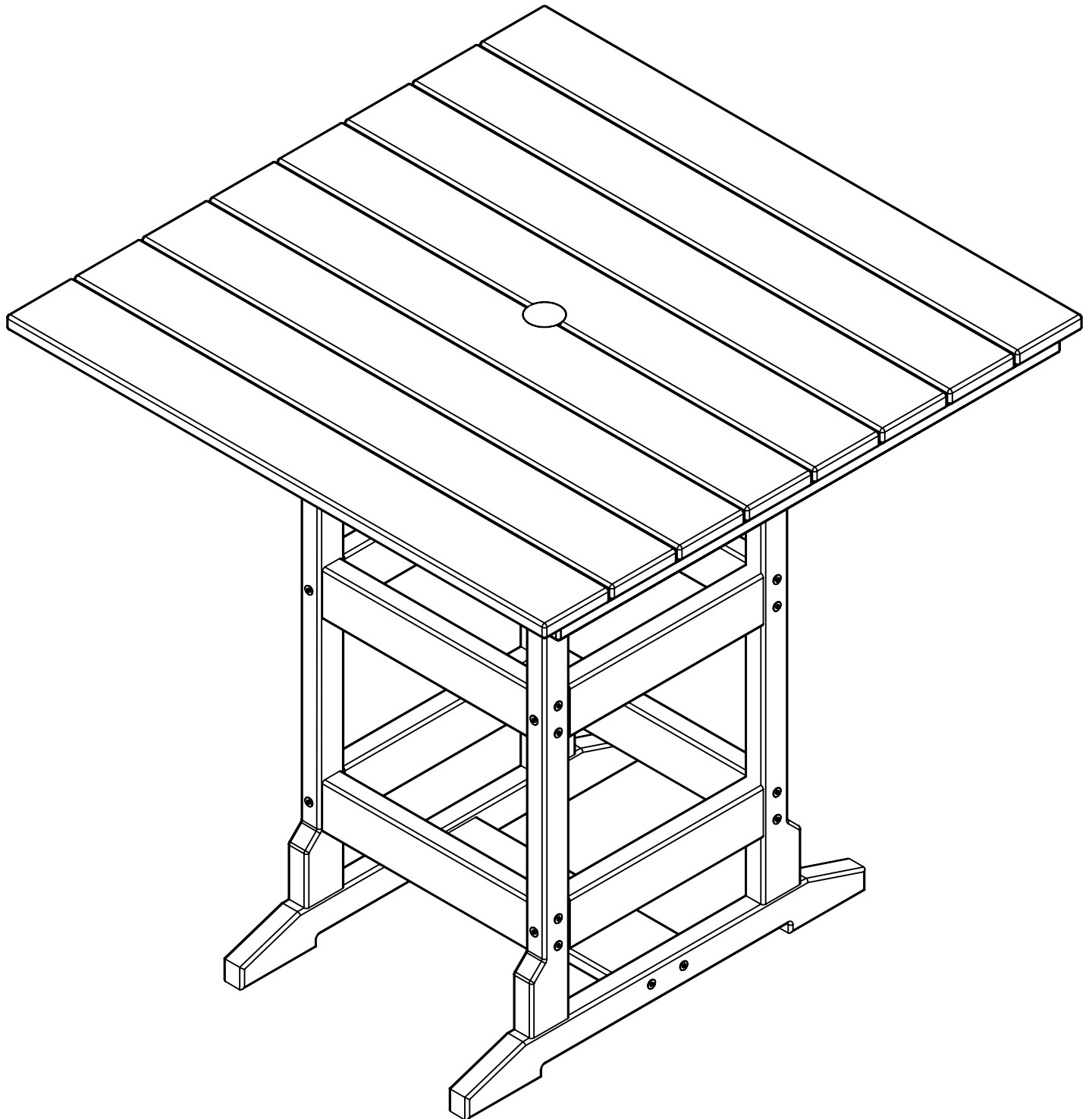

REV00-11/20

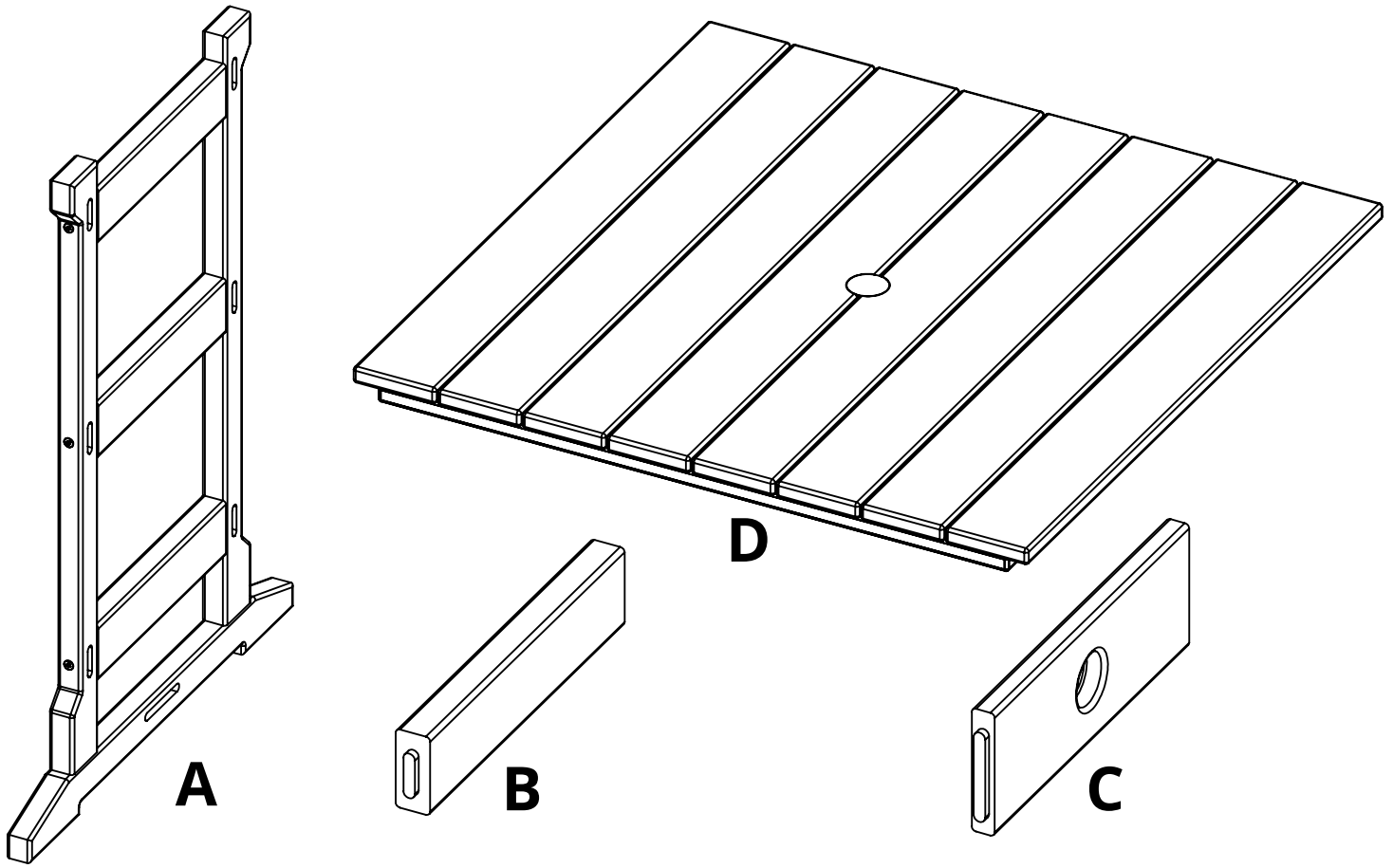

PARTS			
PART	DESCRIPTION	PART NO.	QTY
A	SIDE ASSEMBLY	SA-00321	2
B	SPREADER	PRT-00634	6
C	BASE SPREADER	PRT-00635	1
D	TABLE TOP ASSEMBLY 42"x 42" SQ ENDED	SA-00457	1

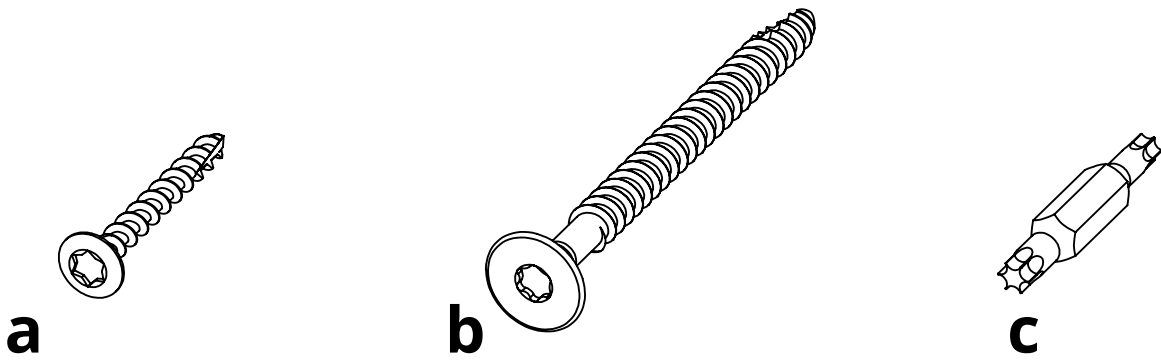

HARDWARE			
PART	DESCRIPTION	PART NO.	QTY
a	#8 X 2" TORX SCREW	H-0000-S82	4
b	1/4-10 X 3" LAG	H-0000-S103	28
c	T20 & T25 TORX BIT	H-0000-CTD	1

Suggested Tools: Drill, Plastic Mallet

Please read entire instructions before beginning

- 1.** Attach Part B and Part C to Part A using Hardware b

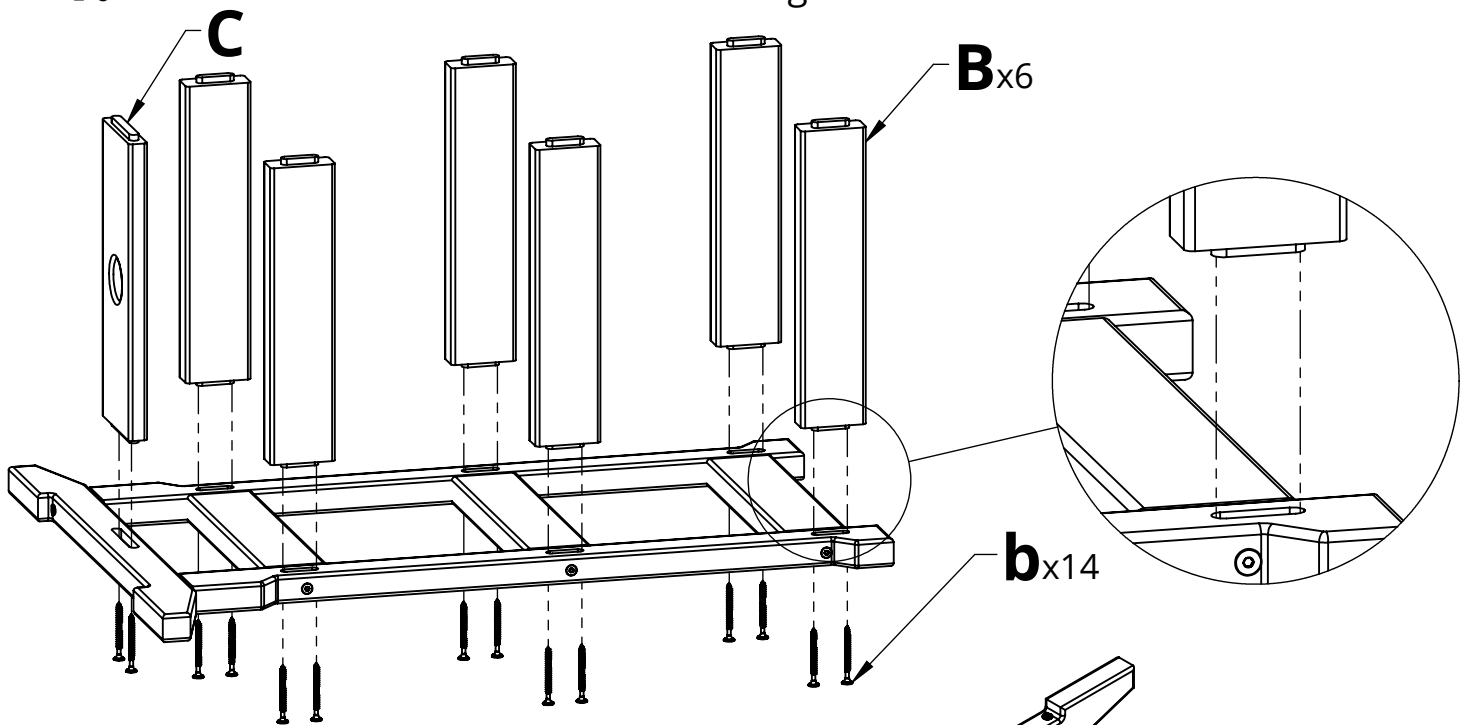

- 2.** Place second Part A on assembled piece from Step 1; Repeat Step 1

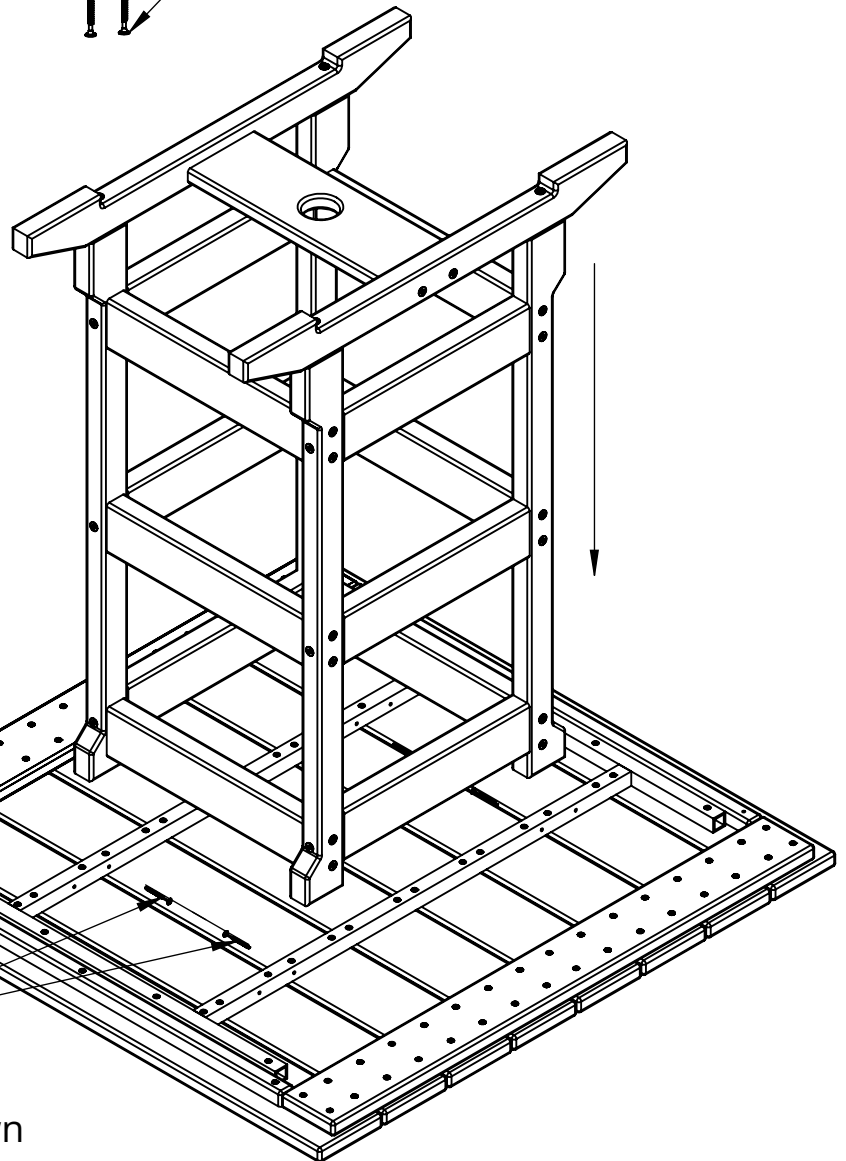

- 3.** Attach the assembly from steps 1 & 2 onto Part D using Hardware a

May be easier if assembled upside down