

A

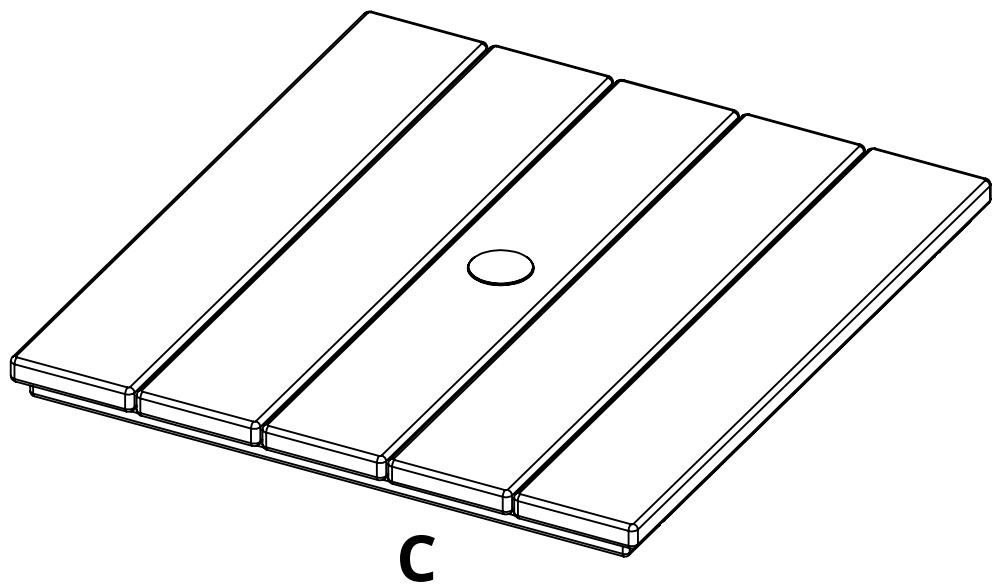

C

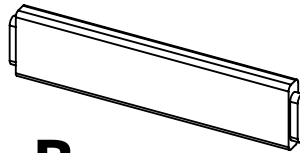

B

PARTS

PART	DESCRIPTION	PART NO.	QTY
A	SIDE ASSEMBLY	SA-00034	2
B	STOOL SPREADER	SS-11.25	6
C	TABLE TOP ASSEMBLY 26"x 28"	SA-00322	1

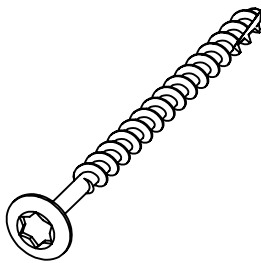

a

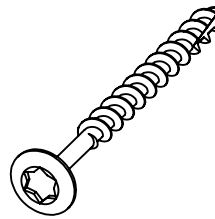

b

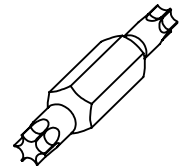

c

HARDWARE

PART	DESCRIPTION	PART NO.	QTY
a	#8 2-1/2" TORX SCREW	H-0000-S825	12
b	#8 X 2" TORX SCREW	H-0000-S82	10
c	T20 & T25 TORX BIT	H-0000-CTD	1

Suggested Tools: Drill, Plastic Mallet

Please read entire instructions before beginning

1. Attach Part B to Part A using Hardware a

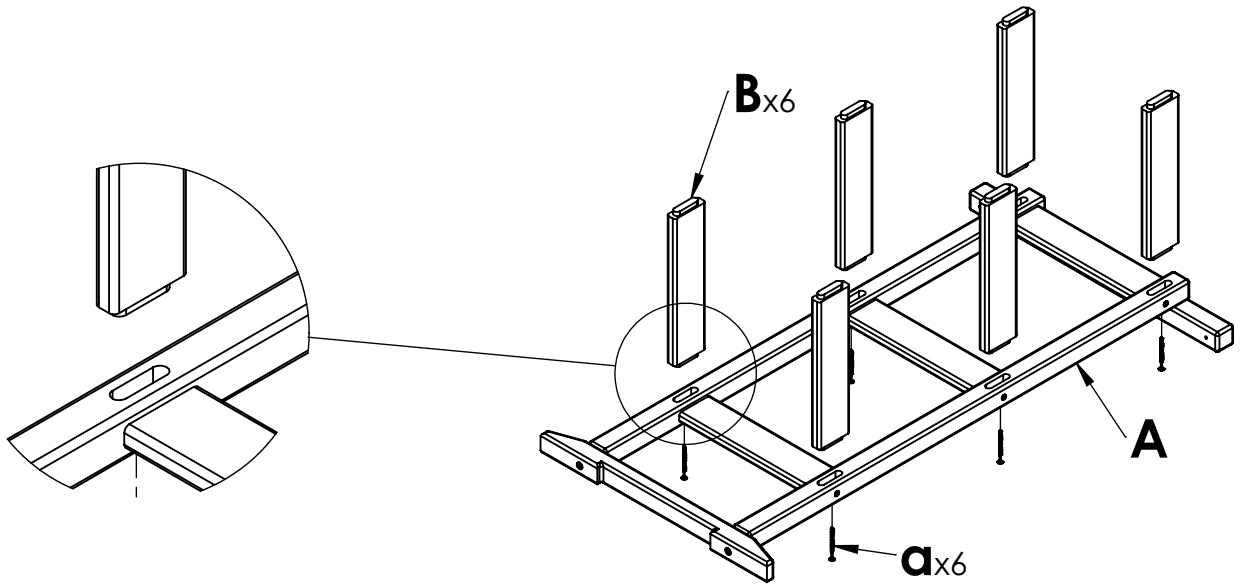

2. Place second Part A on assembled piece from Step 1, Attach with Hardware a

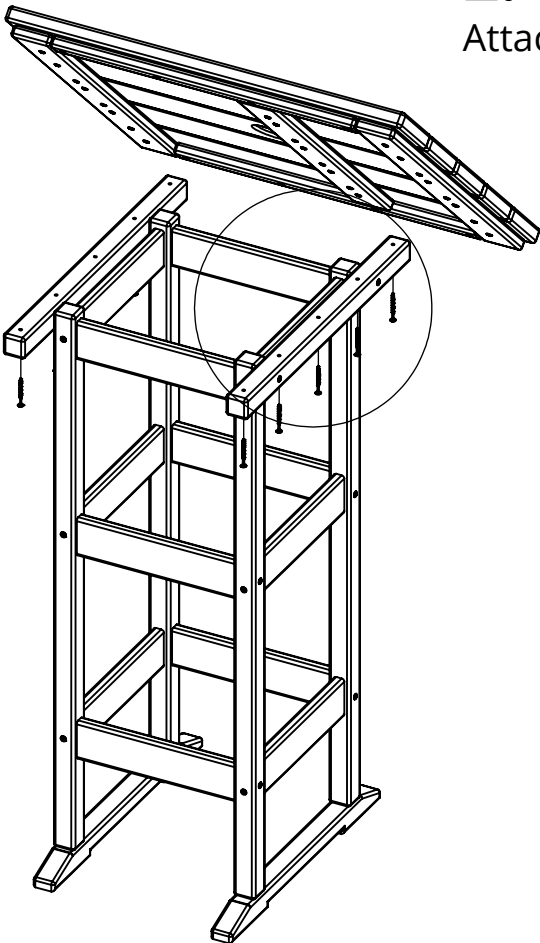

3. Place Part C onto Part A, attach using Hardware b

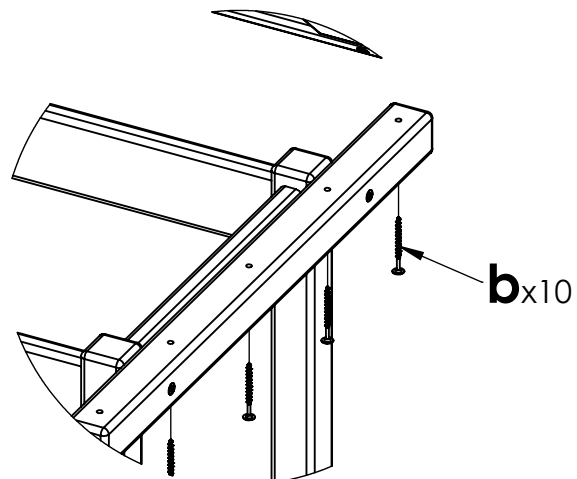

May be easier if assembled upside down