

## PARTS

PART	DESCRIPTION	PART NO.	QTY
A	FRONT LEG ASSEMBLY	SA-00080	2
B	LEFT BACK LEG ASSEMBLY	SA-00081	1
C	RIGHT BACK LEG ASSEMBLY	SA-00082	1
D	UNDER ARM SUPPORT	PRT-00146	2
E	LEFT ARM ASSEMBLY	SA-00066	1
F	RIGHT ARM ASSEMBLY	SA-00067	1
G	FOOT REST	PRT-00168	1
H	SEAT ASSEMBLY	SA-00068	1
I	LEG BASE ASSEMBLY	SA-00078	1
J	BACK ASSEMBLY	SA-00069	1

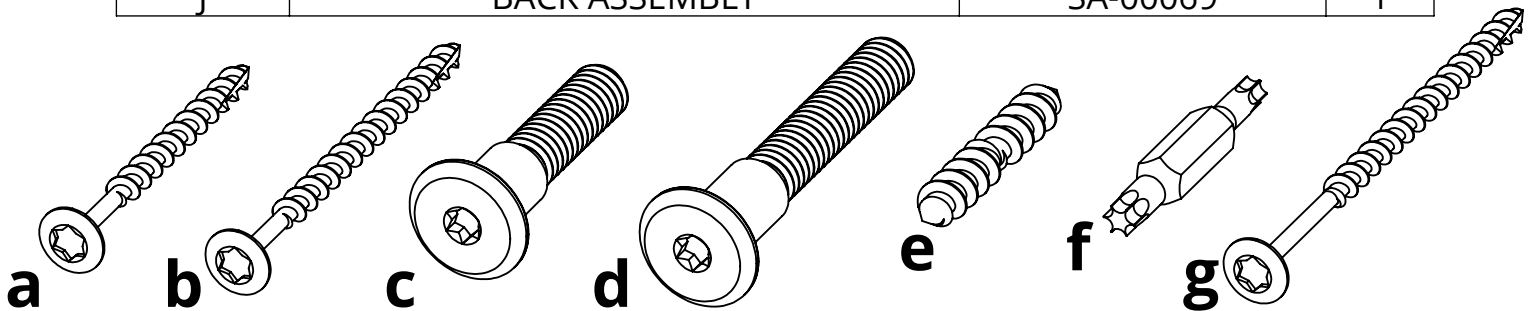

## HARDWARE

PART	DESCRIPTION	PART NO.	QTY
a	#8 X 2" TORX SCREW	H-0000-S82	2
b	#8 X 2-1/2" TORX SCREW	H-0000-S825	4
c	5/16" X 1-1/2" CHAIR BOLT	H-0000-CB51615	2
d	5/16" X 2-1/8" CHAIR BOLT	H-0000-CB516218	12
e	DOUBLE SCREW	H-0000-DS	4
f	T20 & T25 TORX BIT	H-0000-CTD	1
g	#8 X 3" TORX SCREW	H-0000-S83	4

**Suggested Tools:** Drill, Plastic Mallet

# Please read entire instructions before beginning

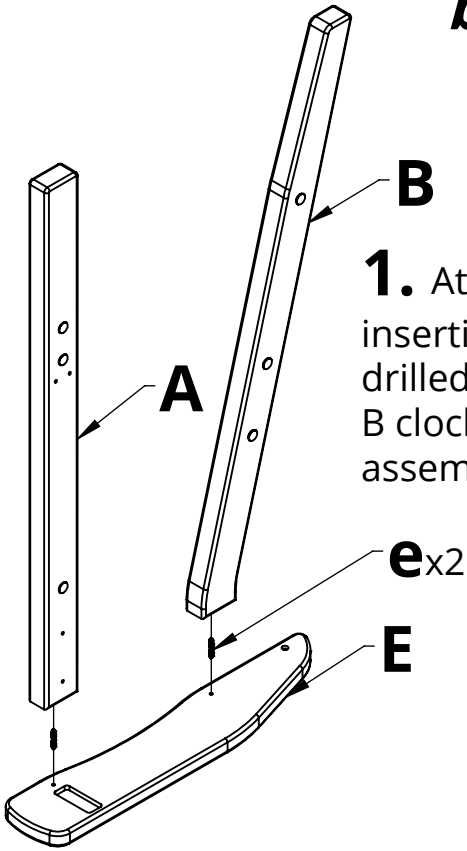

**1.** Attach Parts A & B to Part E by inserting Hardware e into the pre-drilled holes and rotating Parts A & B clockwise, stopping when the assembly is tight

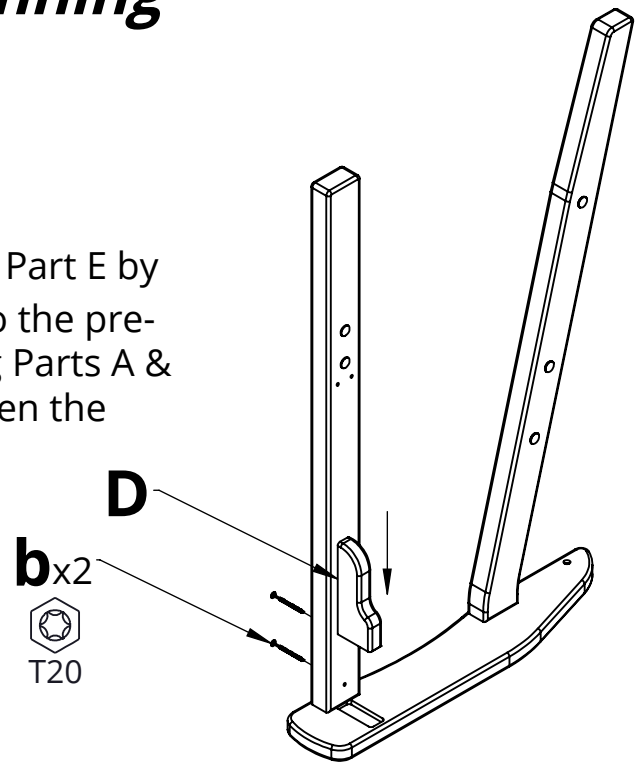

**2.** Attach Part D to the previous assemblies using Hardware b

**3.** Repeat Steps 1 & 2 with Parts A, C, F & D

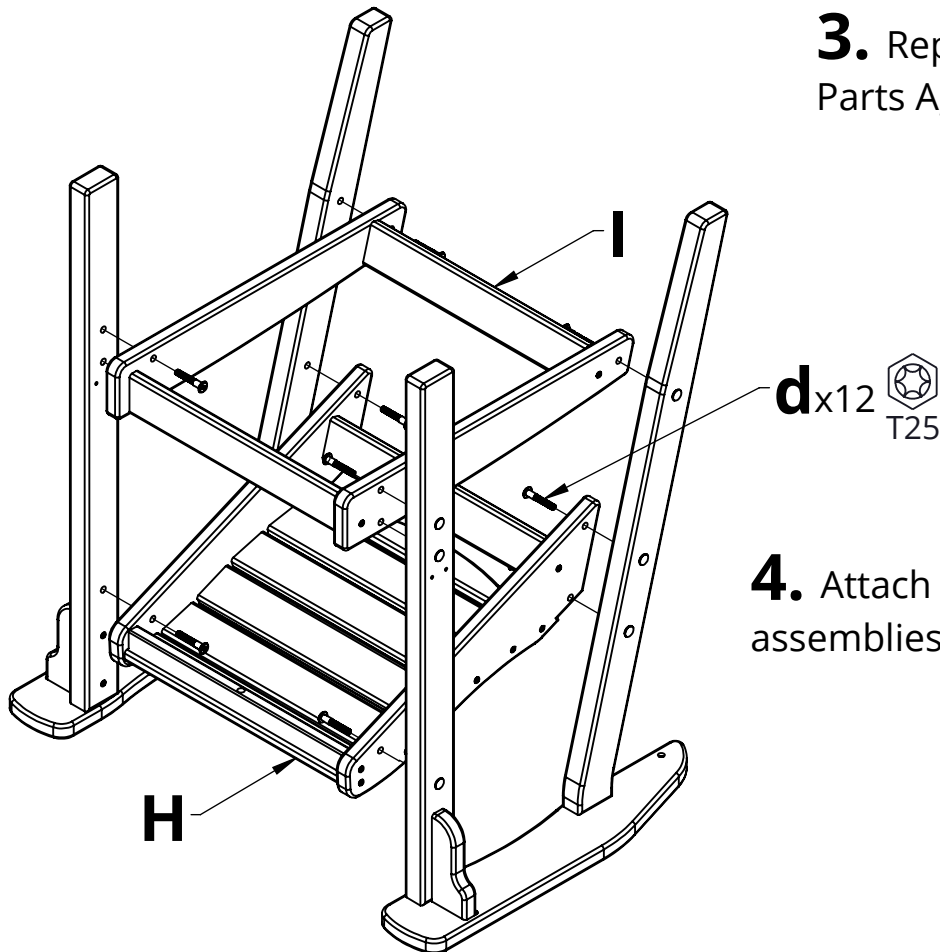

**4.** Attach Parts H & I to the previous assemblies using Hardware d

**5.** Drop Part G into place and secure it with Hardware g as shown

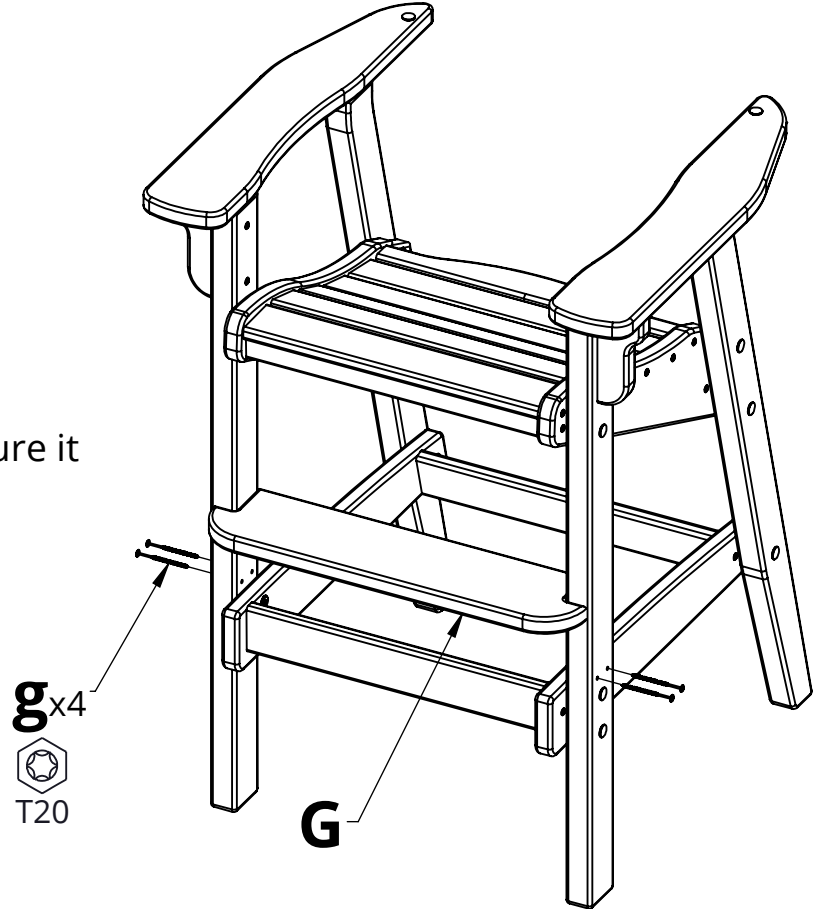

**6.** Slide part J into place and connect it as shown

