

PARTS			
PART	DESCRIPTION	PART NO.	QTY
A	LEFT ARM	PRT-00239	1
B	RIGHT ARM	PRT-00240	1
C	LEFT FRONT LEG	PRT-00241	1
D	RIGHT FRONT LEG	PRT-00242	1
E	ANGLED SPREADER	PRT-00213	2
F	FRONT/BACK RAIL	PRT-00235	2
G	SPREADER	PRT-00236	1
H	SEAT ASSEMBLY	SA-00125	1
I	BACK ASSEMBY	SA-00129	1
J	STRAIGHT SPREADER	PRT-00226	2

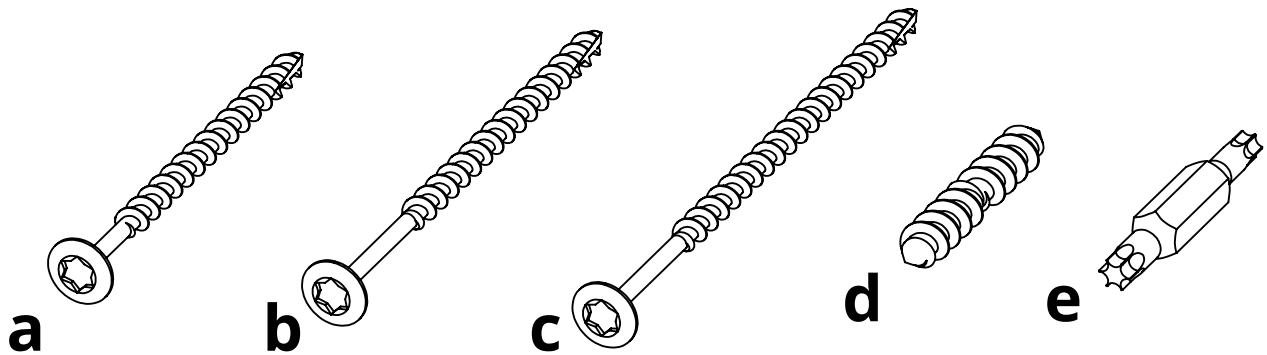

HARDWARE			
PART	DESCRIPTION	PART NO.	QTY
a	#8 X 2-1/2" TORX SCREW	H-0000-S825	6
b	#8 X 3" TORX SCREW	H-0000-S83	8
c	#8 X 3-1/2" TORX SCREW	H-0000-S835	6
d	DOUBLE SCREW	H-0000-DS	2
e	T20 & T25 TORX BIT	H-0000-CTD	1

**Suggested Tools:** Drill, Plastic Mallet

# Please read entire instructions before beginning

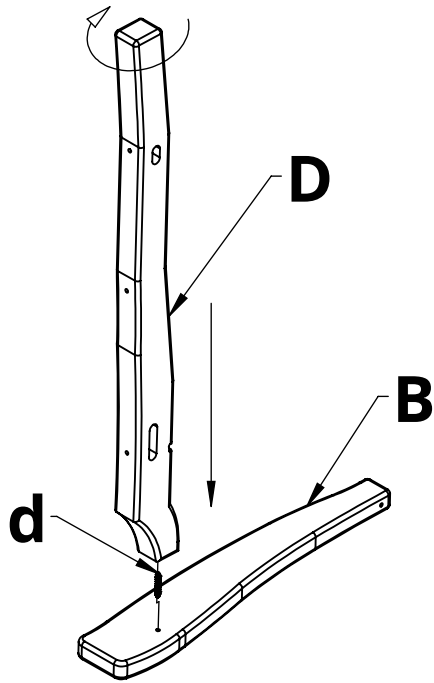

**1.** Rotate Part D clockwise onto Part B with Hardware d, stop when the connection is snug & in the correct orientation

**2.** Repeat Step 1 with Parts A & C

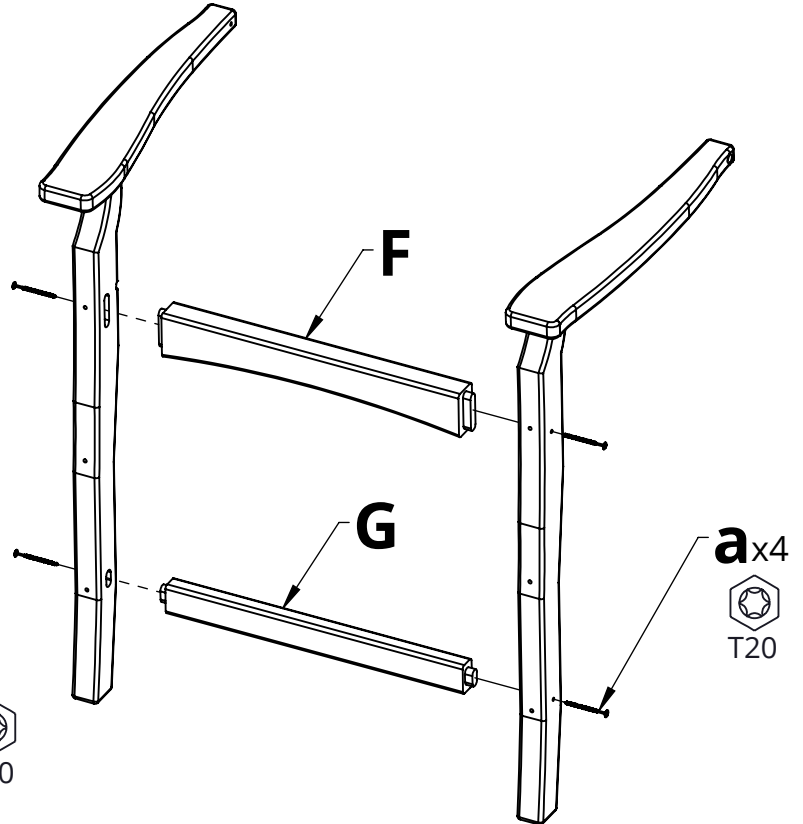

**3.** Place Parts F & G between the previous assemblies and connect them as shown

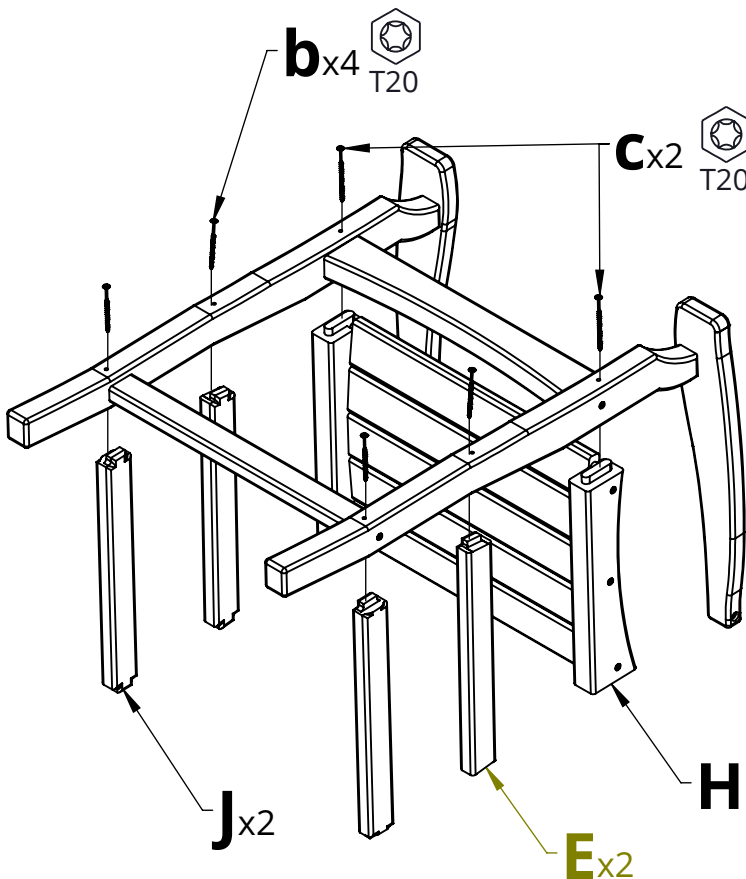

**4.** Insert Parts H, E, & J into the assembly as shown and connect them using the hardware shown

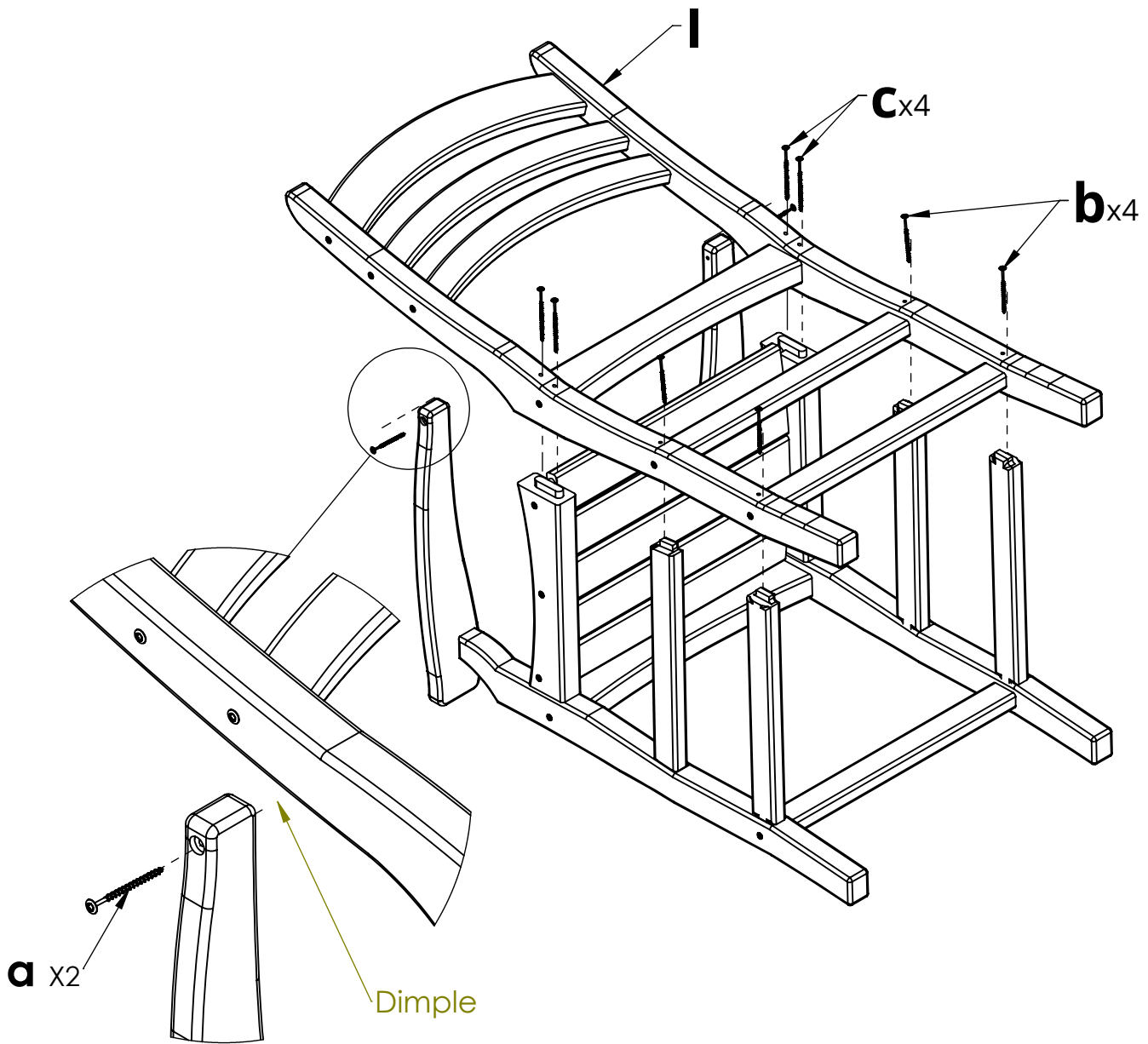

**5.** Turn the assembly over & attach Part I as shown. Note there is a dimple in each side of the back assembly to assist in aligning the arms to the back legs