

MGB454/654W

KOLD-DRAFT  **CLASSIC**

Marine Cuber with Manifold Installation Instructions

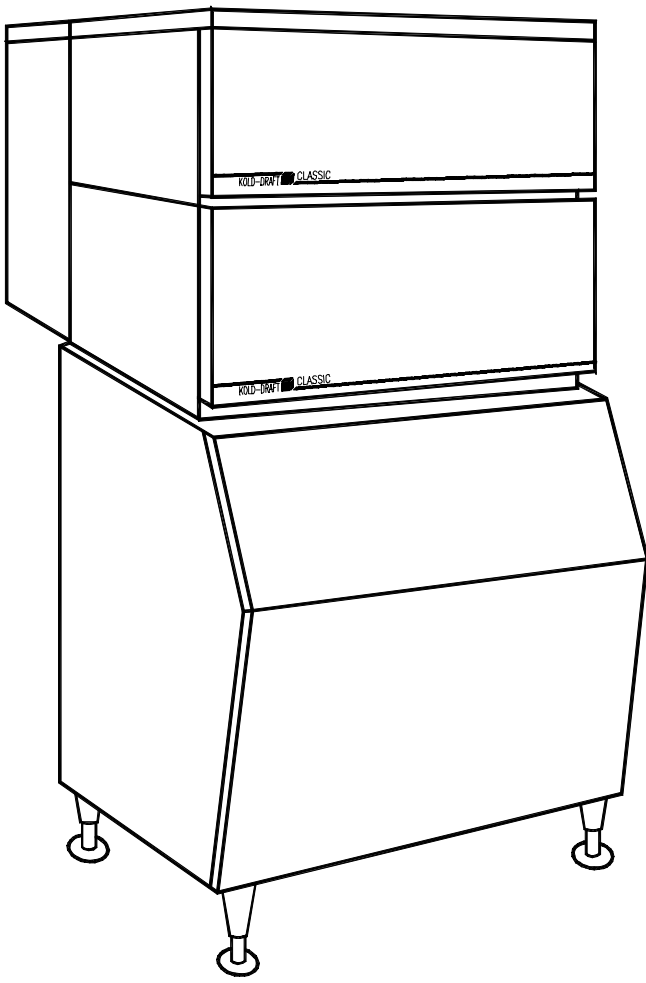

® KOLD-DRAFT 

Ice Machine Products

1525 East Lake Road, Erie, PA 16511-1088
814/453-6761
FAX 814/455-6336

©2004 KDIndustries, Inc., Erie, PA U.S.A.
Printed in U.S.A. 3/04
508 1039 01

A Tradition of Excellence In Ice Equipment.

INSTALLATION AND OPERATION INSTRUCTIONS FOR KOLD-DRAFT® MARINE ICE CUBERS

CHECK FOR FREIGHT DAMAGE BEFORE PROCEEDING: Even though damage to the carton may not have been evident, check for hidden damage and contact freight carrier immediately if necessary to file a claim.

THIS EQUIPMENT MUST BE INSTALLED IN COMPLIANCE WITH THE APPLICABLE FEDERAL, STATE/PROVINCE, AND/OR LOCAL PLUMBING,

CAUTION:

- ◆ RISK OF PERSONAL INJURY, PROPERTY DAMAGE, EQUIPMENT FAILURE, OR FIRE.
- ◆ Refer all maintenance to qualified personnel.
- ◆ Never operate this equipment with covers, panels, or other parts removed or not properly secured.
- ◆ Warn all users to clean up spillage immediately, keep storage bin doors closed, and report any apparent leakage or unusual sounds to responsible maintenance personnel.

ELECTRICAL, AND HEALTH/SANITATION CODES AND REQUIREMENTS. INSTALLATION

1. Position the ice storage bin so that the following minimum clearances will be available around the ice maker for ventilation and utility connections:
REAR (beyond condenser if protruding from cabinet) and **TOP**: 6 inches
RIGHT SIDE: 8 inches
LEFT SIDE : 4 inches

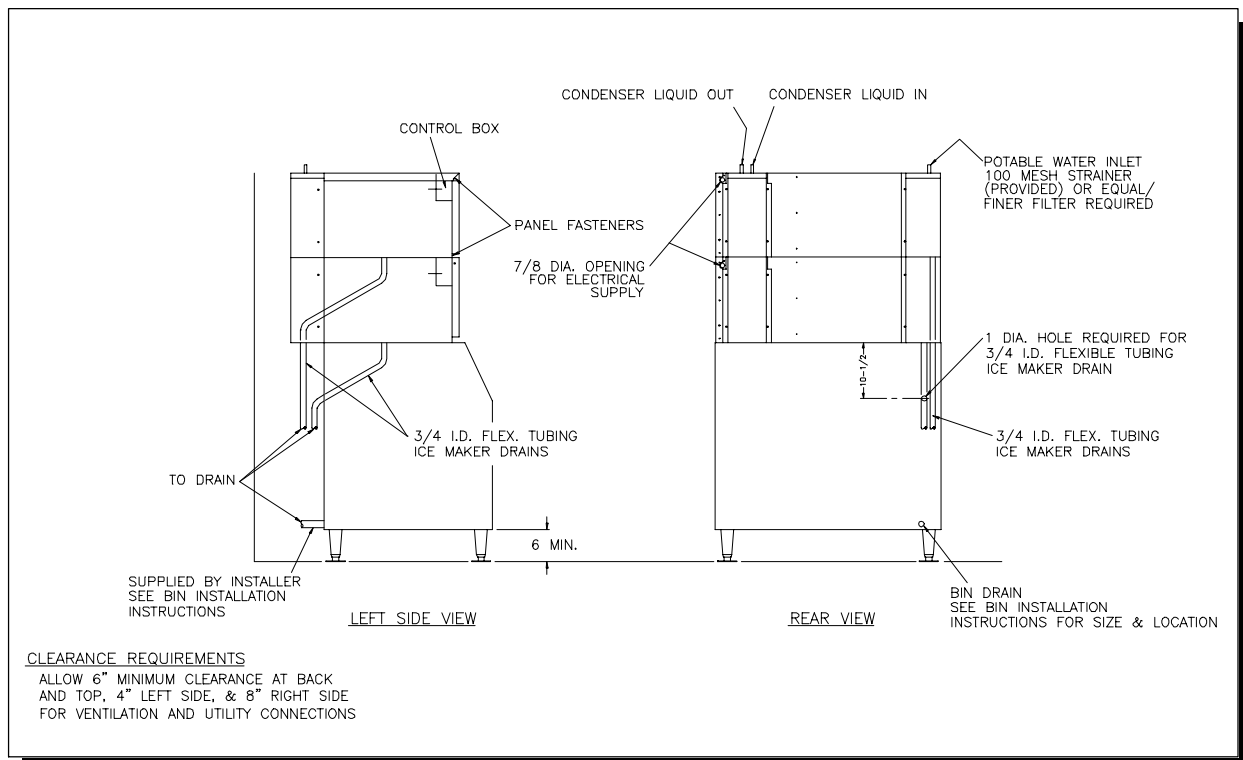

2. Level the bin with adjusters on legs, or by shimming if the bin is to be sealed to the floor. If gaps due to shims are greater than 1/8 inch, install a cove molding around the bin bottom. Seal the bin or molding to the floor with NSF Certified RTV sealant (Dow-Corning RTV 732 or equal).
3. Remove the cuber cabinet TOP panel as follows:
Lift from the front and pull forward until the rear clip is disengaged from the chassis.
4. *CAREFULLY* lift the cuber out of the carton and onto the floor.

CAUTION:

- ◆ RISK OF PERSONAL INJURY OR EQUIPMENT DAMAGE.
- ◆ Use a suitable lifting means and be careful of sharp edges.

5. Remove the remaining cuber cabinet panels as follows:
FRONT: Remove the (5) screws at the bottom and front-sides, pull forward.
SIDES : Pull forward and lift to disengage the clips from the chassis.
NOTE: When re-installing the panels, be sure that the screws engage the TOP panel.
6. Remove the ice deflectors, ice chutes and drain pans. Drain tubes are packed with the drain pans.
7. Install gasketing on top of bin if required. Gasket material must be positioned so that it extends to the outside edge of the perimeter of the cuber chassis when the cuber is in place.
8. *CAREFULLY* place the cuber onto the gasketed bin, noting the alignment of the mounting holes in the chassis if mounting means are provided on the bin. Follow the bin installation instructions for securing the cuber to the bin.
9. Install the drain pans, ice chutes and ice deflectors. Route the drain tubes through the rear of the bin and the back of the lower ice machine, and clamp the tubing to the drain pan nipples.

10. Typical drain tubing shown on the following drawing.

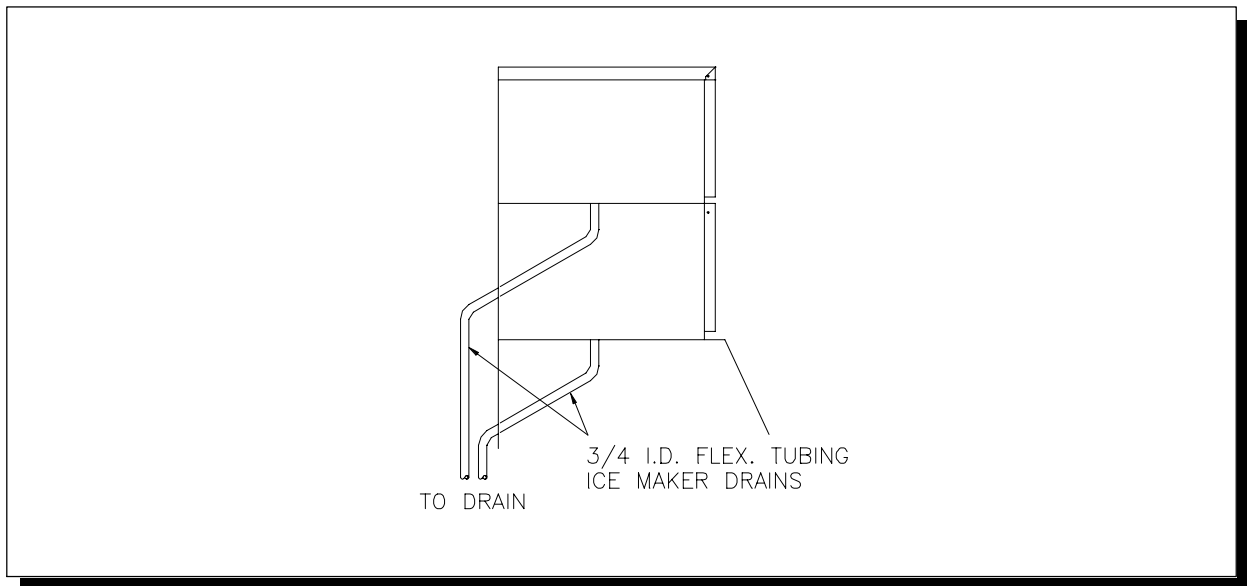

11. Electrical, water and drain locations are shown on the following drawing: All dimensions are in inches.

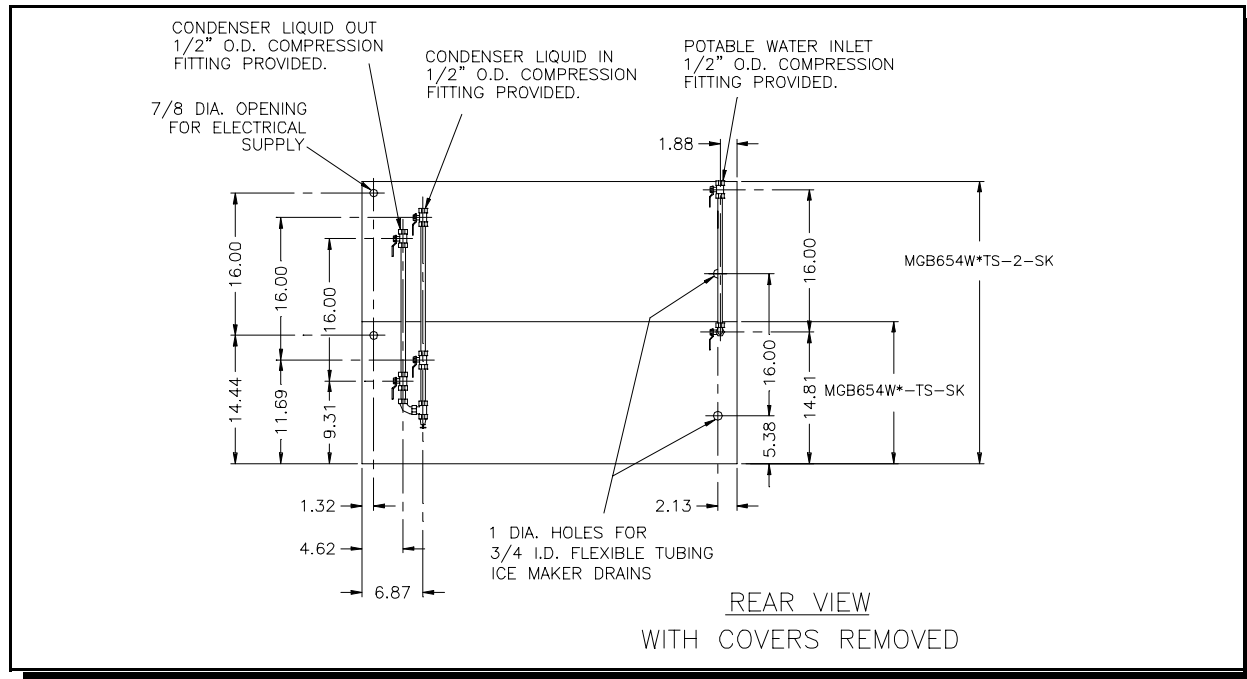

12. Purge the potable water supply line.

WARNING:

- ◆ RISK OF CONTAMINATION OF ICE IN THE BIN.
- ◆ Provide separate, unconnected drains for the ice maker and the bin.
- ◆ Consult local codes for suitable connections to the ship drains.

13. Remove the water plate shipping strap(s).
14. Route the bin thermostat capillary tube through the grommet in the compressor compartment wall and under the ice chute. See the diagram and notes following for location and securing of the capillary tube. The capillary tube clips will be toward the drain pan when properly installed.

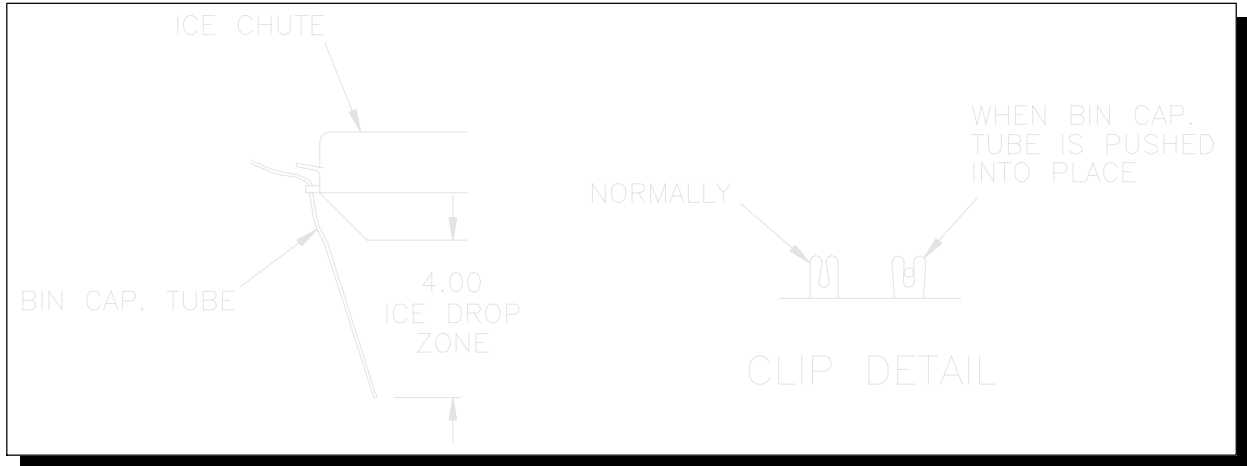

15. If start-up will not occur immediately, secure all cuber cabinet panels now.

INSTALLATION SPECIFICATIONS

MODEL	ELECTRICAL SUPPLY	MINIMUM CIRCUIT AMPACITY	FUSE / HACR BREAKER SIZE (AMPS)		WATER INLET SIZE (COMP)	ICE MAKER DRAIN SIZE (ID)	CONDENSER COOLANT (COMP)	
			NORMAL	MAXIMUM			SUPPLY	DISCHARGE
MGB654W	208-230/60/1	17.3	20	30	1/2	3/4	1/2	1/2

READ THE FOLLOWING NOTES CAREFULLY PRIOR TO MAKING CONNECTIONS

<u>Voltage tolerances:</u>	Nominal 208-230	No-load MAXIMUM 252	Full-load MINIMUM 198
----------------------------	--------------------	---------------------------	-----------------------------

CAUTION:

- ◆ RISK OF PROPERTY DAMAGE, EQUIPMENT FAILURE OR FIRE
- ◆ Failure to comply with all installation specifications and instructions may cause erratic operation and the risk of damage or fire

Ampacity: Minimum ampacity does not indicate typical running current value. Refer to equipment NAME PLATE data. Use minimum ampacity value for sizing branch circuit conductors up to 25 feet length. For conductor length over 25 feet up to 100 feet, increase 1 AWG size. Over 100 feet requires 2 or more AWG size increase.

Branch circuit protection: Proper protection must be provided by either fuse(s) or HACR type circuit breaker(s). Each ice maker must be provided with a separately protected circuit with no other load(s). A fused disconnect installed adjacent to each ice maker is recommended (must be supplied by the installer), and may be required by local codes. NORMAL protector size is based on rated voltage and operation at lower than extreme temperature limits. When branch circuit conductors are sized to permit, increasing the protector size (up to the specified maximum) may avoid nuisance protector opening under harsh operating conditions.

Water supply: Minimum 30 psig supply pressure while the ice maker is filling is required. Maximum supply pressure is 100 psig. The water fill flow rate is 1 GPM for each MGB654W machine. Backflow/back-siphonage protection is provided by an internal air gap (accepted by NSF). If additional protection is required by local codes or authorities, any device(s) and installation of the same, including specification and cost, are the responsibility of the installation specifier.

Ice maker drain: The size of the gravity drain for the ice maker purge and rinse water must not be reduced. Individual drains from stacked ice makers may be discharged into a standpipe or manifold with a minimum 1-1/2 inch air gap at each ice maker connection.

Liquid condenser coolant pressure drop: Condenser coolant pressure drop may reach 20 psig during peak load with 85°F. coolant temperature at recommended refrigerant high-side pressure. The condenser coolant (water) regulating valve may require adjustment due to variations in the coolant supply characteristics to provide optimum efficiency.

All models are intended FOR INDOOR USE ONLY with PERMANENT CONNECTION TO THE FIELD ELECTRICAL SUPPLY.

Other operating condition requirements:

Ice maker ambient air temperature: MINIMUM 45°F.; MAXIMUM 90°F.

Potable water and condenser liquid supply:

Temperature: MINIMUM 45°F.; MAXIMUM 90°F.

Pressure: MINIMUM 30 psig; MAXIMUM 100 psig*

*If regulator is used, recommended setting is 30 to 50 psig.



KOLD-DRAFT supports all efforts to preserve our environment. Since commercial refrigerants are suspected of being harmful to the environment, NEVER VENT REFRIGERANT INTO THE ATMOSPHERE.

START-UP INSTRUCTIONS

WATER LEVELS, CYCLE TIMES, AND REFRIGERANT CHARGES

PARAMETER	MGB654WC/HK
Water fill level (Top of tank to level in control tube)	2-3/4"
*Approximate cycle time, min.	18
Refrigerant charge (R-404a), oz.	23
Approximate harvest weight, lb.	7.1

* Values are at 90°F. air/70°F. water temperatures with cuber adjusted to produce fully-formed ice. Greater capacity can be obtained by reducing the water fill level (lowering the high-level probe) to produce ice with larger dimples. A slight adjustment of the probe will result in a noticeable effect on dimple size. The control stream will not rise over the dam with lower water fill levels than indicated above.

CAUTION: REFRIGERANT CHARGES MUST BE ACCURATELY WEIGHED.

Consult the specification and troubleshooting guide if variations from the following description of operation are noticed:

1. Remove the top and front cabinet panels.
2. Be sure that the "ICE-OFF-WASH" switch is in the center (OFF) position.
3. Turn on supply water and power. Be sure that condenser liquid are ready for use before turning power on. Check for leaks in water/liquid supply connections.
4. Be sure that pump hoses are connected, then put about one pint of clean tap water into the circulation system to lubricate the pump seal.
5. Move the "ICE-OFF-WASH" switch to the right "WASH" position and observe the water fill cycle and the pump running. If all water distributor holes do not produce full streams and the appearance of air is evident in the tube, pinch the plastic tube connected to the water solenoid valve outlet while water is running until the streams are full all the way across the distributor tube. Water fill is complete when the water in the liquid level control tube reaches the high-level probe. At this time observe that the water shuts off and that there are no water leaks (dripping into the drain pan).
6. Pull the right end of the water plate down, stretching the springs until the pump stops, and hold until the pump does not re-start when released. The water plate will open fully to dump the batch of water previously taken in, then close

immediately. The water plate should stop when it is fully closed, and the water fill cycle will repeat.

7. After the water fill is complete, move the "ICE-OFF-WASH" switch to the left "ICE" position and observe that the compressor starts, and the water pump continues to run. The refrigeration system operation should be checked during the first few cycles, and any adjustments should be made at this time. Consult the "adjustments" section in the service manual. Initial ice making cycles may exhibit super-cooling of the circulating water so that ice crystals form in the circulating water ("slush"), possibly stopping the flow momentarily. If water goes over the control stream dam when circulation resumes after two (2) cycles AND with all skin panels installed, consult the Factory.
8. Test the bin thermostats by holding some ice against the capillary tubes. If necessary, adjust the thermostats so that the ice makers shut off within 30 seconds after ice contacts the capillary tubes.
9. Be sure that the drain pans ice chutes and deflectors are in place, and that the electrical control box covers are secured, then replace the cabinet panels (skins). Start with the SIDE panels, then the FRONT panel, secure the FRONT panel with (3) screws along the bottom edge, replace the TOP panel and finally secure all the panels with (2) screws in the TOP-SIDES of the machine.
10. Discard ice from start-up cycles, then clean and sanitize the bin following the instructions provided with the bin.
11. Complete and mail the Registration Certificate and leave this manual with the owner/user. Emphasize the "CAUTION: RISK OF PERSONAL INJURY..." NOTICE ON THE FRONT PAGE, and the importance of the PREVENTATIVE MAINTENANCE recommendations below.

PREVENTATIVE MAINTENANCE

CLEANING: Usually at 3 to 6 month intervals, depending on water conditions.

INSPECTIONS: During cleaning - at least twice a year.

SERVICE: All such equipment will require service at some time. Service requirements will be minimized with faithful preventative maintenance including good housekeeping at the installation site. A CALL FOR SERVICE AS SOON AS A POSSIBLE PROBLEM IS NOTICED MAY AVOID EXTENSIVE REPAIRS.

ICE CUBER CLEANING INSTRUCTIONS

CAUTION:

- ◆ RISK OF PERSONAL INJURY OR PROPERTY DAMAGE.
- ◆ Do not use ammonia solutions in cleaning any part of the ice maker.
- ◆ Do not mix ice machine cleaner and sanitizer together.
- ◆ Use rubber gloves, eye protection and an apron.
- ◆ Clean up splashes or spillage immediately.
- ◆ Follow these instructions exactly.

1. Mix one bag of KOLD-DRAFT ice machine cleaner (55R-01000-B) in two (2) quarts of clean, warm water (180°F. MAX.) for each evaporator/water plate assembly to be cleaned.
2. If the cuber is operating, wait until a harvest cycle occurs then trip the "ICE-OFF-WASH" switch to "WASH" as soon as the water plate begins to close.
3. Empty all ice from the storage bin and shut off other ice makers on the same bin.
4. After the water fill is completed, switch the "ICE-OFF-WASH" to "OFF". While pinching water level control hose, carefully remove the water level control tube from the cap. **HOLD THE TUBE HIGH ENOUGH SO THAT THE TUBE DOES NOT OVERFLOW.** Release the hose and pour about half of the mixed cleaner into the tube. Replace the tube on the cap, while pinching water level control hose, then pour the remaining cleaner into the control stream box.
5. Switch the "ICE-OFF-WASH" to "WASH" and allow the cleaner to circulate for approximately 15 minutes, then pull the right side of the water plate down until the pump stops and hold it until the pump will not re-start when released.
6. The water plate will open and dump the cleaner then close immediately, and the water system will refill. Repeat this dumping and refilling three (3) times to rinse out all of the cleaning solution.
7. Mix a sanitizing solution of two (2) oz. 5-1/4% sodium hypochlorite (household bleach, or equivalent) and one (1) quart of clean water.
8. As in step #4, pour about half of the sanitizing solution into the water level control tube and the remaining sanitizer into the control stream box.
9. Allow the sanitizing solution to circulate **AT LEAST 15 MINUTES**, then dump and rinse two (2) times as described above. If necessary, reset the water level probes to the proper levels.
10. While the cleaning and sanitizing solutions are circulating, clean, rinse, and sanitize all accessible parts of the ice-making compartment of the cuber with clean cloths. Use a cleaning solution of 8 tablespoons (1/2 cup) baking soda per gallon of warm water, and a sanitizing solution of no less than 1 teaspoonful (5 ml) 5-1/4% sodium hypochlorite per quart of clean water.
11. After cleaning has been completed, trip the "ICE-OFF-WASH" switch to "ICE" and check to be sure that the cuber is operating properly, particularly the water level probes. Then re-assemble and secure all cabinet enclosure panels.

ICE CUBER CLEANING INSTRUCTIONS

ICE BIN CLEANING INSTRUCTIONS

The bin should be cleaned periodically. If bin drain has any horizontal run, remove ice from left side of bin and flush with two quarts of hot water monthly. (Long drain lines should be flushed weekly.)

1. Clean exterior of bin frequently.
2. To clean the interior, follow instructions provided with bin.
3. Empty the storage area and disconnect the electrical power supply to the ice maker(s).
4. Remove the ice maker inspection panel, top, left and right end panels, and drain pan. Sliding bin doors may be removed by lifting them up, then pulling out from the bottom.
5. When cleaning the ice maker, follow the ice maker cleaning instructions and clean the bin last.
6. Replace all enclosure panels before re-connecting the electrical supply.

CAUTION:

- ◆ RISK OF PERSONAL INJURY, EQUIPMENT DAMAGE OR CONTAMINATION OF THE ICE BIN.
- ◆ Do not use ammonia solutions or strong detergents in cleaning any part of the ice maker or bin.
- ◆ Never use appliance polishers or other finish preservatives or cleaners in ice storage areas.

WINTER CONDITIONING

Ice cubers that are idle in the winter months require preparation to prevent damage from freezing. The following procedure should insure the safety of the machine so that it can be started easily the following year.

1. Shut off and detach the water supply to the Ice Cuber.
2. If the cuber contains a water-cooled condenser, the cuber must be running while air is introduced through the condenser water inlet connection to blow water out of the condenser coils.
3. The machine should then be run into defrost to drain the water tank and the air blown into the water inlet to blow out the water solenoid.

MARINE MULTIPLEXING INSTRUCTIONS

STACKING ADDITIONAL UNITS, IF REQUIRED

CAUTION:

- ◆ RISK OF PERSONAL INJURY, PROPERTY DAMAGE, EQUIPMENT FAILURE OR FIRE.
- ◆ Refer all maintenance to qualified personnel.
- ◆ Never operate this equipment with covers, panels or other parts removed or not properly secured.
- ◆ Use a suitable lifting means and be careful of sharp edges.

1. Remove cabinet panels from upper and lower ice makers.
2. Mount support clips on top side flanges of lower ice maker frame and position so the clip holes are aligned with the holes in the frame. (See Illustration "A") The lower flange of the front support clips must slide into the space between the

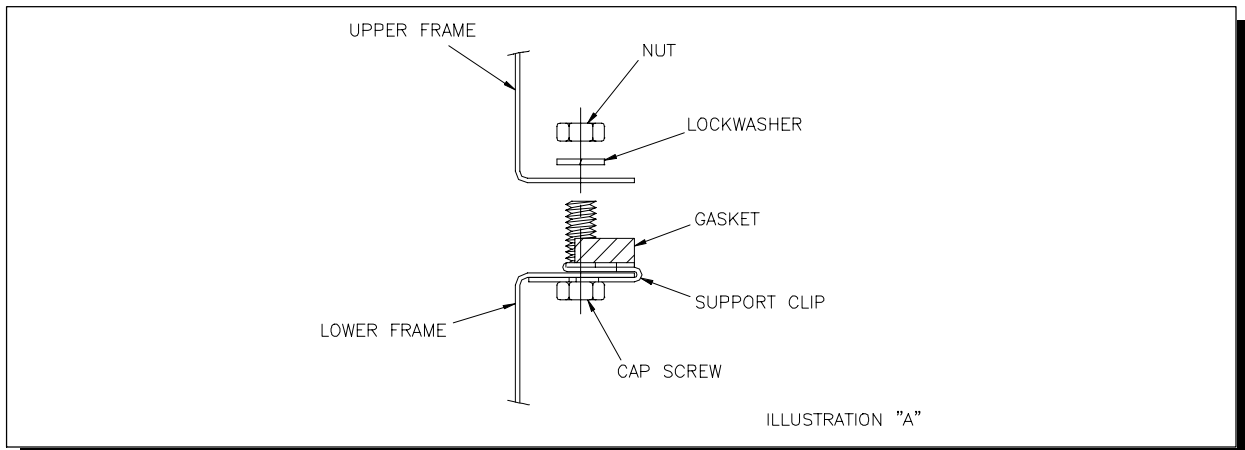

top side flange of the ice maker and the top flange of the electrical box.

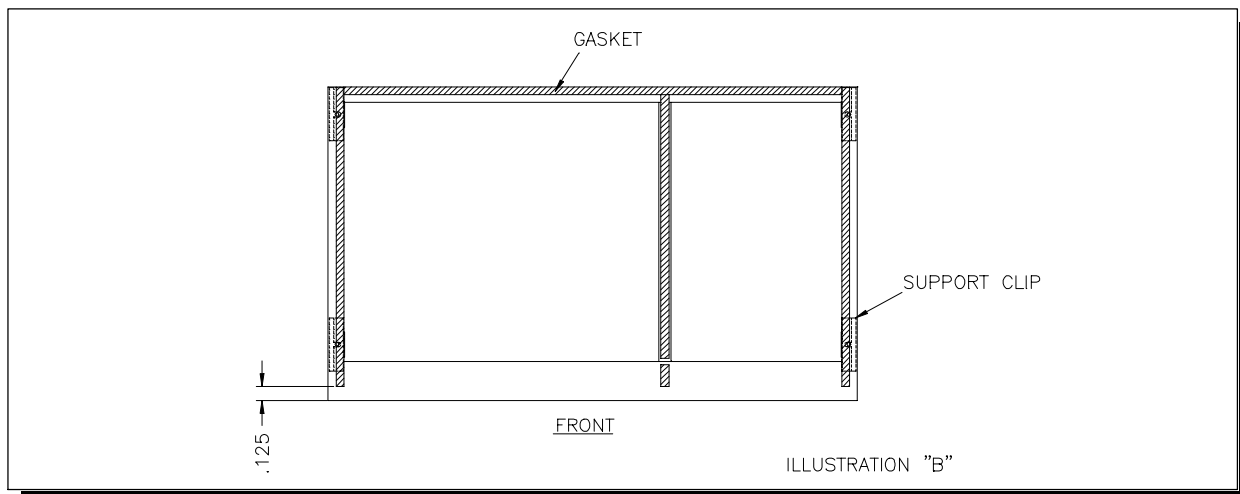

3. Apply gasket supplied with stacking kit to lower ice maker frame and cut to fit. (See Illustration "B") Place gasket over the support clips already in position and pierce the gasket where it covers the mounting holes.

WIRING DIAGRAM
KOLD DRAFT 'CLASSIC' ICE CUBE MAKER
GB4XX AND GB6XX SERIES

COLOR CODE	
BK	BLACK
B/G	BLACK/GREEN
B/W	BLACK/WHITE
BU	BLUE
GY	GRAY
O	ORANGE
PK	PINK
R	RED
R/W	RED/WHITE
W	WHITE
Y	YELLOW
Y/BU	YELLOW/BLUE
Y/O	YELLOW/ORANGE

VOLTAGE	① WIRE COLOR	② CAPACITOR	③ WIRE COLOR
115 V/60 HZ.	WHITE	4 mF/250 VAC	BLACK
220-240 V/50 HZ.	BLUE	1 mF/370 VAC	RED
208-230 V/60 HZ.	BROWN	1 mF/370 VAC	RED

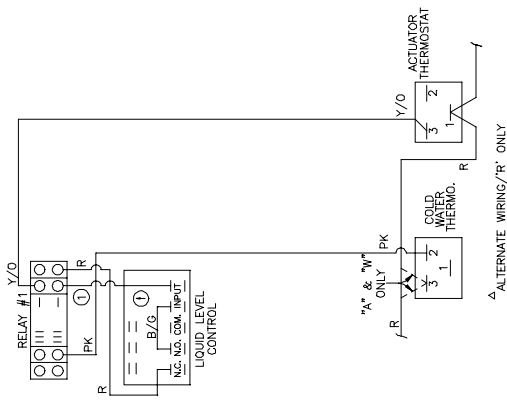
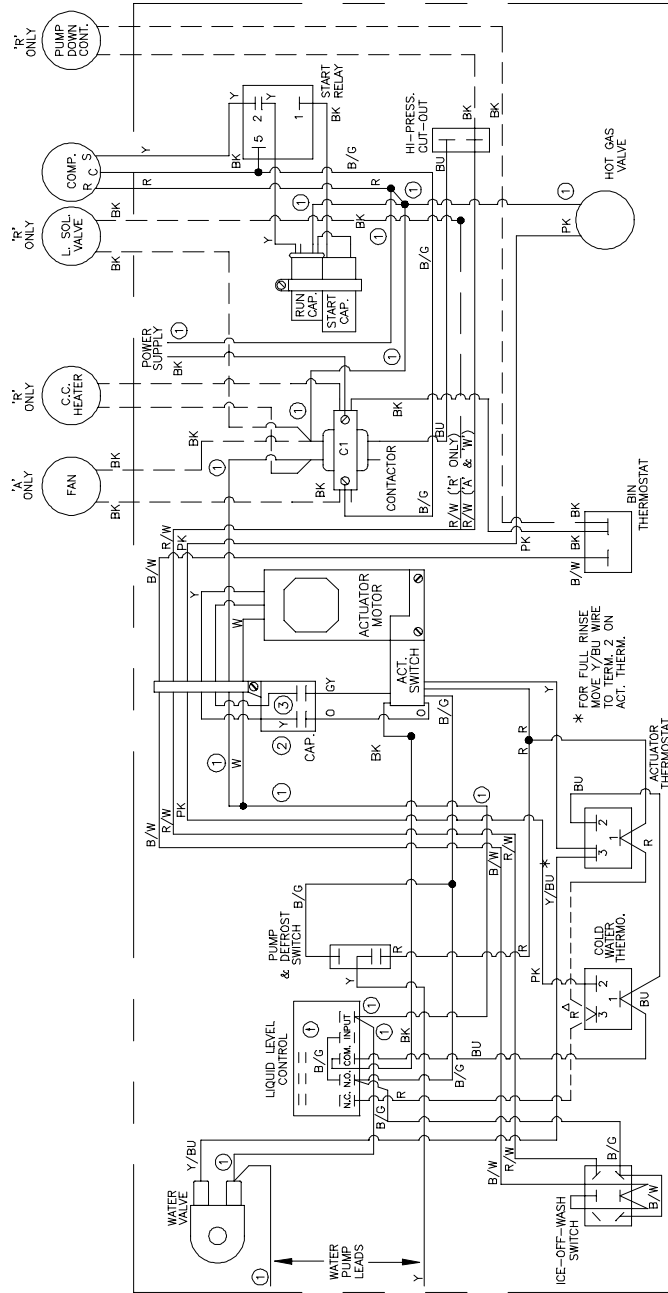

WIRING DIAGRAM
KOLD DRAFT 'CLASSIC' ICE CUBE MAKER
GB4XX AND GB6XX SERIES

COLOR CODE	
BK	BLACK
B/G	BLACK/GREEN
B/W	BLACK/WHITE
BU	BLUE
GY	GRAY
O	ORANGE
PK	PINK
R	RED
R/W	RED/WHITE
W	WHITE
Y	YELLOW
Y/BU	YELLOW/BLUE
Y/O	YELLOW/ORANGE

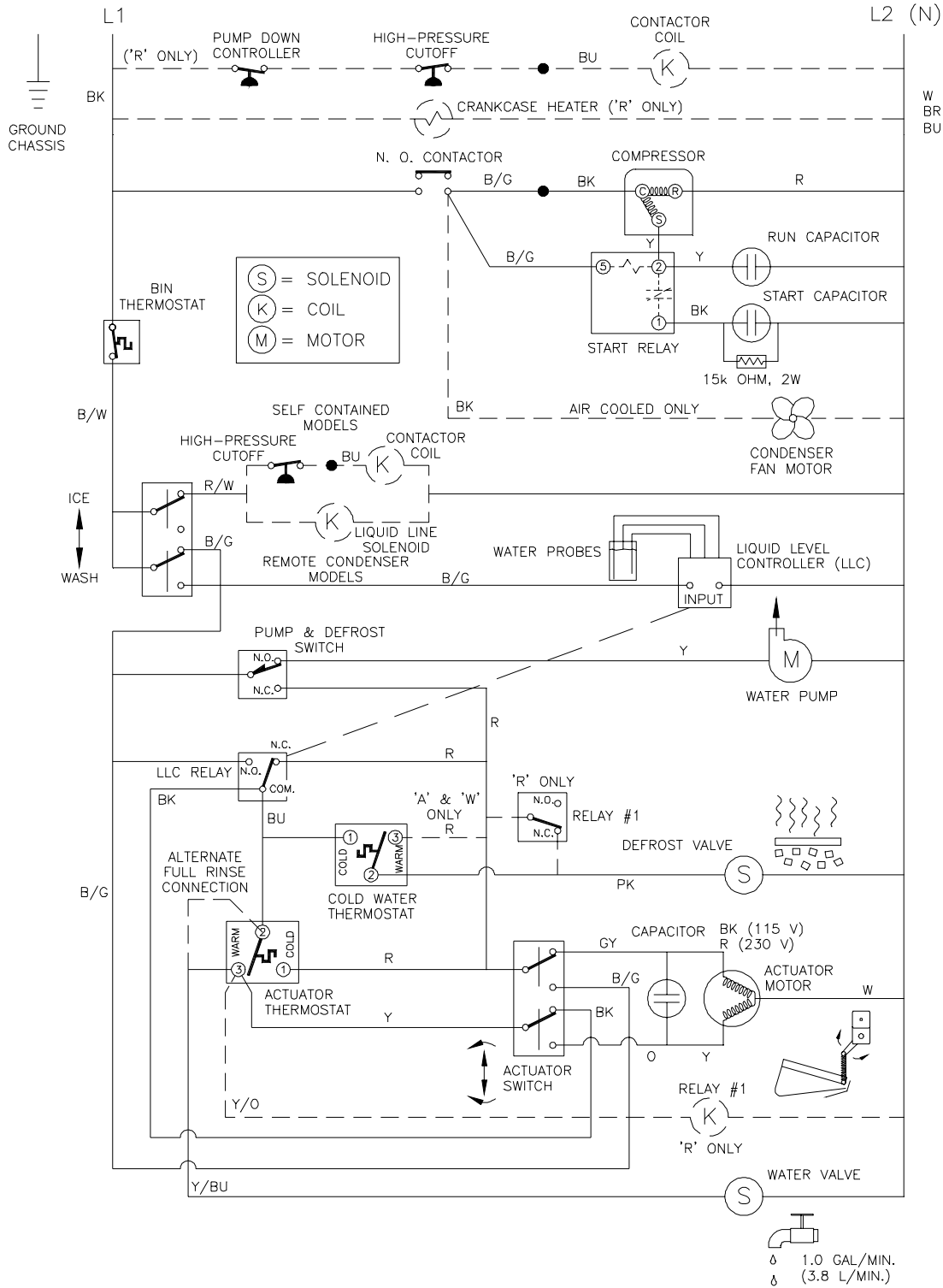

4. Position upper ice maker on lower unit and align mounting holes. Install cap screws, lock washers and nuts. (See Illustration "A") **CAUTION:** Support upper unit until all fasteners are secured.
5. Install the upper ice maker drain pan and ice chute. Connect the drain hose to the drain pan and route the drain hose through the rear of the lower ice maker.
6. Route upper ice maker bin thermostat capillary tube down to the lower ice maker chute opening for positioning. Keep capillary tube toward front of partition wall out of the path of falling ice. Note- For all machines stacked above two high, a bin thermostat with a longer capillary tube is required. Contact the factory for more information.
7. Install the side cabinet panels. Follow start-up instructions, included with ice maker, to complete installation.

