



KOLD-DRAFT®

ice machines • bins • crushers • dispensers

2020 BROCHURE



WE ARE A FRIENDLY, FLEXIBLE COMPANY,
AND OUR ICE MAKERS ARE PRETTY DARN SMART, TOO.

KOLD-DRAFT	OUR HISTORY	01
	GBX1060 ICE MACHINE	02
	GBX560 ICE MACHINE	03
	GTX560 ICE MACHINE	04
	GTX360 ICE MACHINE	05
	GB1060 ICE MACHINE	06
	GB560 ICE MACHINE	07
	GT560 ICE MACHINE	08
	GT360 ICE MACHINE	09
	HD200 / HDX200 SERIES ICE DISPENSERS	10
	T280 ICE CRUSHER	11
	COCKTAIL SERIES	12
	SC200 SERIES ICE MACHINE	13
	ICE BINS	14

DETERMINING MODEL NUMBERS

HOW TO DETERMINE THE MODEL NUMBER. WHAT DO THE LETTERS AND NUMBERS MEAN?

ICE SPECIFICATION GUIDE

Soft Drinks @ 3/4 Full of Cubed Ice	Approx. Ice Needed	Soft Drinks @ 3/4 Full of Cubed Ice	Approx. Ice Needed
6 oz. Cup	2 1/2 oz.	20 oz. Cup	7 1/2 oz.
8 oz. Cup	3 oz.	24 oz. Cup	9 oz.
10 oz. Cup	3 1/2 oz.	28 oz. Cup	10 1/2 oz.
12 oz. Cup	4 1/2 oz.	32 oz. Cup	12 oz.
14 oz. Cup	5 oz.	Water Containers	4 lbs./gal.
16 oz. Cup	6 oz.		

Cube Sizes	Uses
Half-Cubes: 1 1/4" x 1 1/4" x 3/8"	Soft Drinks, Mixed Drinks & Airlines
Large Cubes: 1" x 1" x 1 1/4"	Bagged Ice, Tall Drinks, Cocktails & Water Pitchers
Full-Cubes: 1 1/4" x 1 1/4" x 1 1/4"	Bagged Ice, Tall Drinks, Craft Cocktails & Water Pitchers
Crushed Ice	Salad Bars, Iced Foods, Packing & Perishables

Type of Business	Approx. Ice Per Day
Hotel/Motel Room Service	5 lbs. Cubed Ice/room
Hotel/Motel Food Service	1 1/2 lbs. Cubed/Crushed Ice/person
Hotel/Motel Banquet Service	1 lb. Cubed/Crushed Ice/person
Restaurants	3 lbs. Cubed Ice/person
Bars/Cocktail Lounges	3 lbs. Cubed Ice/person
Hospitals	5 lbs. Cubed Ice/bed
Nursing Homes	6 lbs. Cubed Ice/bed
Salad Bars 4" Deep Per Square Foot	8 lbs. Cubed Ice/sq. ft. or 20 lbs. Crushed Ice/sq. ft.
Cafeterias	3 lbs. Cubed Ice/seat

GT = 30" machine
GB = 42" machine

36 = up to 300 lbs. of ice per 24 hours (GT only)
56 = up to 500 lbs. of ice per 24 hours
106 = up to 1000 lbs. of ice per 24 hours (GB only)

1 = 115 Volt, 60 Hz
4 = 208-230 Volt, 60 Hz
7 = 208-230 Volt, 50 Hz ***

A = Air Cooled
L = Liquid Cooled (water)
R = Remote Cooled
(GB1064, GB564, and GT564 only)

C = Full Cube
HK = Half Cube

All Remotes require a separate remote condenser and lines sets to connect the 2 pieces of equipment together.

EXAMPLE:

GT361AC

- 30" Wide
- up to 300 lbs. of ice
- 115 Volt
- Air Cooled
- Full Cube Size

GB564LHK

- 42" Wide
- up to 500 lbs. of ice
- 208-230 Volt
- Liquid Cooled
- Half Cube Size

GB1064RC

- 42.3" Wide
- up to 1000 lbs. of ice
- 208-230 Volt
- Remote Cooled
- Full Cube Size



KOLD-DRAFT

ice Machines • bins • crushers • dispensers

OUR HISTORY



Founded in 1920 in Dayton, Ohio, KOLD-DRAFT's original name was Uniflow for the type of pumps manufactured. In 1926, the plant was moved to its current location in Erie, Pennsylvania. It was from this location that KOLD-DRAFT's reputation for innovation and pure dependability began.

In 1955, KOLD-DRAFT began producing automatic ice machines. Using a unique evaporator and water plate system, KOLD-DRAFT's design produced perfect, pure, clean, hard ice cubes—every time. The "upside down" horizontal evaporator was the key. Water is shot up into the evaporator cells at an incredibly high rate of speed and freezes from the outside in.

This system washes out minerals and foreign substances before the water freezes, producing pure cubes that melt slower. Slower melting ice brings drinks closer to the temperature of the ice without diluting them, keeps food colder longer, and lasts longer in coolers.

World-wide, the finest restaurants, hotel chains, mixologists, bartenders and cocktail enthusiasts call for beautifully crafted ice as the starting point for their food and beverages. Ice is the starting point of any beverage. With KOLD-DRAFT ice as the foundation, any recipe can be fabulous. Kold-Draft machines are engineered to give you 99.9% pure ice.

ICE IN ITS PUREST FORM



FULL ICE CUBE

Few brands have achieved iconic status in ice. Our machines produce the exclusive full cube. The only true square cube in the industry. It's larger and harder than all other ice.

1¼" × 1¼" × 1¼"

HALF ICE CUBE

Kold-Draft's half cube is exactly half the size of the full cube. The half cube provides excellent liquid displacement. The half cube is the right size cube for every purpose.

1¼" × 1¼" × ⅝"

LARGE CUBE

Kold-Draft's large cube is a unique shape. The large cube is an all-purpose cube for usage in all types of beverages. It is only made from our Cocktail Series.

1" × 1" × 1.25"

KOLD-DRAFT

ice Machines • bins • crushers • dispensers



SHOWN WITH KDB650 BIN

Plumbing:

- 3/4" FPT potable water inlet
- 3/4" FPT bin drain
- 3/4" I.D. flex tubing cuber drain
- 3/8" FPT condenser (liquid-cooled) inlet
- 1/2" FPT condenser (liquid-cooled) outlet

Exterior Finish:

300 Series stainless steel

Refrigeration System:

Thermostatic expansion valve controlled R-404A-HFC

Clearance Requirements:

Allow 4" left side, 8" right side and back, and 6" top for ventilation and utility connections.

Condenser Heat Rejection:

BTUH/kW/Ton
13,850/4.06/1.15 avg.
18,000/5.3/1.5 peak



1 1/4" x 1 1/4" x 1 1/4" 1 1/4" x 1 1/4" x 3/8"

IT'S NICE TO BE NOTICED™

X-SERIES

GBX1060 – ICE MACHINE

THE X-SERIES WORKHORSE

Produces up to 1,000lbs of ice per day! The X-Series from Kold-Draft features rounded corners, plastic top panels, plastic louvers and an LCD display. X-Series machines are stackable with other X-Series machines. Double the capacity in the same footprint!

Dimensions/Weight

Description	Dimensions / inches (cm)			Ship Weight
	W	D	H	
Air Cooled	42.3" (107.4cm)	31.1" (79cm)	33.7" (85cm)	360lb (163.3kg)
Liquid Cooled	42.3" (107.4cm)	25.7" (65.3cm)	33.7" (85cm)	320lb (145kg)
Remote Air Cooled	42.3" (107.4cm)	25.7" (65.3cm)	33.7" (85cm)	320lb (145kg)

Recommended Operating Requirements:

	MIN.	MAX.
Room Air Temp.	45°F (7°C)	110°F (43°C)
Water Temp.	45°F (7°C)	90°F (32°C)
Voltage 208-230	198V	253V
Potable Water Pressure	20 PSIG (137 kPa)	100 PSIG (689 kPa)
Liquid-Cooled Condenser Pressure	20 PSIG (137 kPa)	100 PSIG (689 kPa)

GBX1060 Series Daily Capacities: Lbs. of ice per 24 hours per unit

Model Number	Electrical Volt/ Hz/Ph	Condenser	Cube Size	Ice Capacity 24 Hours lbs. (kg)		Energy Input 90°F (32°C) 70°F (21°C) kWh/100 lbs. (kJ/kg)	Water Use gal/100# (l/kg) 90°F (32°C) 70°F (21°C)		MCA	MOP	Required Condenser	
				70°F (21°C) 50°F (10°C) Ambient/ Water	90°F (32°C) 70°F (21°C) Ambient/ Water		Potable	Condenser				
GBX1064AC	208-230/60/1	Air Cooled	Full Cube	1075 (488)	860 (390)	4.9 (389)	12.9 (1.1)	n/a	11	20	n/a	
GBX1064AHK			Half Cube	1066 (484)	881 (400)	4.9 (389)	13.0 (1.1)		11	20		
GBX1064LC		Liquid Cooled	Full Cube	1047 (475)	918 (416)	4.1 (325)	16.4 (1.4)	174 (14.5)	10	20		
GBX1064LHK			Half Cube	1089 (494)	931 (422)	4.1 (325)	15.3 (1.3)	157 (13.1)	10	20		
GBX1064RC		Remote Air Cooled	Full Cube	959 (435)	767 (348)	5.3 (421)	12.6 (1.1)	n/a	11	25		RC314APV
GBX1064RHK			Half Cube	1031 (468)	838 (380)	5.1 (405)	15.0 (1.3)		11	25		

Use Model # GBX1067AHK, GBX1067AC, GBX1067LHK, GBX1067LC, GBX1067RHK, GBX1067RC to Indicate 220/50/1.

RC Condenser Series

Model Number	Description	Dimensions / inches (cm)			Gross Weight
		W	D	H	
RC314APV	Single-circuit vertical air flow remote condenser, vapor-charged with resealable quick-connect fittings, for GB1064R Cubers	40.75" (103.5cm) including interconnect fitting housing	22.75" (57.8cm)	30.2" (76.6cm) including 10" (25.4 cm) legs and fan guard	140lb (63.5kg)



Made in USA



Intertek COMPONENT



COMPONENT



WARRANTY ON ALL PARTS & LABOR (EXCLUDES INSTALLATION ONLY)

X-SERIES

GBX560 – ICE MACHINE

THE X-SERIES SIGNATURE

Produces up to 500lbs of ice per day! The X-Series from Kold-Draft features rounded corners, plastic top panels, plastic louvers and an LCD display. X-Series machines are stackable with other X-Series machines. Double the capacity in the same footprint!

Dimensions/Weight				
Description	Dimensions / inches (cm)			Ship Weight
	W	D	H	
Air Cooled	42.3" (107.4cm)	31.1" (79cm)	17" (43.2cm)	215lb (97.5kg)
Liquid Cooled	42.3" (107.4cm)	25.63" (65.1cm)	17" (43.2cm)	200lb (90.7kg)
Remote	42.3" (107.4cm)	25.63" (65.1cm)	17" (43.2cm)	200lb (90.7kg)

Recommended Operating Requirements:

	MIN.	MAX.
Room Temp.	45°F (7°C)	110°F (43°C)
Water Temp.	45°F (7°C)	90°F (32°C)
Voltage 208-230	198V	253V
Voltage 115	104V	126V
Potable Water Pressure	20 PSIG (137 kPa)	100 PSIG (689 kPa)
Liquid-Cooled Condenser Pressure	20 PSIG (137 kPa)	100 PSIG (689 kPa)

GBX560 Series Daily Capacities: Lbs. of ice per 24 hours per unit

Model Number	Electrical Volt/Hz/Ph	Condenser	Cube Size	Ice Capacity 24 Hours lbs. (kg)		Energy Input 90°F (32°C) / 70°F (21°C) kWh/100 lbs. (kJ/kg)	Water Use gal/100# (l/kg) 90°F (32°C) / 70°F (21°C)		MCA	MOP	Required Condenser
				70°F (21°C) Ambient/Water	90°F (32°C) Ambient/Water		Potable	Condenser			
GBX561AC	115/60/1	Air Cooled	Full Cube	490 (222)	402 (182)	5.9 (468)	14.0 (1.2)	n/a	14	30	n/a
GBX561AHK			Half Cube	502 (228)	412 (187)	5.9 (468)	16.0 (1.3)	13	30		
GBX561LC		Liquid Cooled	Full Cube	559 (254)	474 (215)	4.8 (381)	14.7 (1.2)	157 (13.1)	13	30	
GBX561LHK			Half Cube	585 (265)	513 (233)	4.6 (365)	16.3 (1.4)	126 (10.5)	13	30	
GBX564AC	208-230/60/1	Air Cooled	Full Cube	483 (219)	413 (187)	6.0 (476)	13.9 (1.2)	n/a	7	20	
GBX564AHK			Half Cube	542 (246)	448 (203)	5.8 (460)	16.8 (1.4)	7	20		
GBX564LC		Liquid Cooled	Full Cube	543 (246)	456 (207)	4.9 (389)	14.0 (1.2)	162 (13.5)	7	20	
GBX564LHK			Half Cube	598 (271)	522 (237)	4.7 (373)	14.7 (1.2)	181 (15.1)	7	20	
GBX564RC		Remote Air Cooled	Full Cube	495 (225)	427 (194)	6.4 (508)	14.4 (1.2)	n/a	8	20	
GBX564RHK			Half Cube	508 (230)	458 (208)	6.2 (492)	16.2 (1.4)	8	20		

Use Model # GBX567AHK, GBX567AC, GBX567LHK, GBX567LC to Indicate 220/50/1.

RC Condenser Series

Model Number	Description	Dimensions / inches (cm)			Gross Weight
		W	D	H	
RC214APV	Single-circuit vertical air flow remote condenser, vapor-charged with re-sealable quick-connect fittings for GB/GT564R Cubers	40.75" (103.5cm) including interconnect fitting housing	22.75" (57.8cm)	30.2" (76.6cm) including 10" (25.4cm) legs and fan guard	135lb (62.4kg)

KOLD-DRAFT

ice Machines • bins • crushers • dispensers



SHOWN WITH KDB650

Plumbing:

- 3/4" FPT potable water inlet
- 3/4" FPT bin drain
- 3/4" I.D. flex tubing cuber drain
- 3/8" FPT condenser (liquid-cooled) inlet
- 1/2" FPT condenser (liquid-cooled) outlet

Exterior Finish:

300 Series stainless steel

Refrigeration System:

Thermostatic expansion valve controlled R-404A-HFC

Clearance Requirements:

Allow 4" left side, 8" right side and back, and 6" top for ventilation and utility connections.

Condenser Heat Rejection:

BTUH/kW/Ton
6,500/1.91/0.54 avg
8,750/2.6/0.729 peak

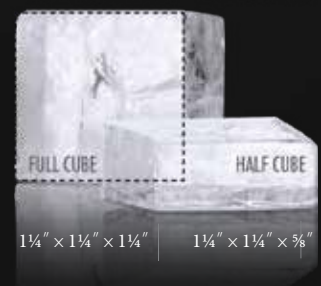

IT'S NICE TO BE NOTICED™



KOLD-DRAFT

ice Machines • bins • crushers • dispensers



SHOWN WITH KDB400

Plumbing:

- 3/4" FPT potable water inlet
- 3/4" FPT bin drain
- 3/4" I.D. flex tubing cuber drain
- 3/8" FPT condenser (liquid-cooled) inlet
- 1/2" FPT condenser (liquid-cooled) outlet

Exterior Finish:

300 Series stainless steel

Refrigeration System:

Thermostatic expansion valve controlled R-404A-HFC

Clearance Requirements:

Allow 4" left side, 8" right side and back, and 6" top for ventilation and utility connections.

Condenser Heat Rejection:

BTUH/kW/Ton
6,500/1.91/0.54 avg.
8,750/2.6/0.729 peak

X-SERIES GTX560 – ICE MACHINE

THE X-SERIES CLASSIC

Produces up to 500lbs of ice per day! The X-Series from Kold-Draft features rounded corners, plastic top panels, plastic louvers and an LCD display. X-Series machines are stackable with other X-Series machines. Double the capacity in the same footprint!

Dimensions/Weight				
Description	Dimensions / inches (cm)			Ship Weight
	W	D	H	
Air Cooled	30.1" (76.5cm)	25.7" (65.3cm)	30.7" (78cm)	225lb (163.2kg)
Liquid Cooled	30.1" (76.5cm)	25.7" (65.3cm)	30.7" (78cm)	220lb (99.8kg)
Remote	30.1" (76.5cm)	25.7" (65.3cm)	30.7" (78cm)	220lb (99.8kg)

Recommended Operating Requirements:

	MIN.	MAX.
Room Air Temp.	45°F (7°C)	110°F (43°C)
Water Temp.	45°F (7°C)	90°F (32°C)
Voltage 208-230	198V	253V
Voltage 115	104V	126V
Potable Water Pressure	20 PSIG (1.37 kPa)	100 PSIG (689 kPa)
Liquid-Cooled Condenser Pressure	20 PSIG (1.37 kPa)	100 PSIG (689 kPa)

GTX560 Series Daily Capacities: Lbs. of ice per 24 hours per unit

Model Number	Electrical Volt/ Hz/Ph	Condenser	Cube Size	Ice Capacity 24 Hours lbs. (kg)		Energy Input 90 F (32°C) 70 F (21°C) kWh/100 lbs. (kJ/kg)	Water Use gal/100# (l/kg) 90 F (32°C) 70 F (21°C)		MCA	MOP	Required Condenser
				70 F (21°C) 50 F (10°C) Ambient/ Water	90 F (32°C) 70 F (21°C) Ambient/ Water		Potable	Condenser			
GTX561AC	115/60/1	Air Cooled	Full Cube	525 (238)	424 (192)	5.8 (460)	16.0 (1.3)	n/a	14	30	n/a
GTX561AHK			Half Cube	538 (244)	424 (192)	5.9 (468)	18.3 (1.5)		13	30	
GTX561LC		Liquid Cooled	Full Cube	543 (246)	477 (216)	4.8 (381)	15.5 (1.3)	166 (13.9)	13	30	
GTX561LHK			Half Cube	561 (254)	484 (220)	4.7 (373)	17.6 (1.5)	184 (15.4)	12	30	
GTX564AC	208-230/60/1	Air Cooled	Full Cube	502 (228)	405 (184)	6.0 (476)	18.8 (1.6)	n/a	7	20	
GTX564AHK			Half Cube	514 (233)	405 (184)	6.0 (476)	18.5 (1.5)		8	20	
GTX564LC		Liquid Cooled	Full Cube	557 (253)	489 (222)	4.8 (381)	13.9 (1.2)	162 (13.5)	7	20	
GTX564LHK			Half Cube	593 (269)	512 (232)	4.8 (381)	15.9 (1.3)	159 (13.3)	7	20	
GTX564RC		Remote Air Cooled	Full Cube	496 (225)	413 (187)	6.5 (516)	13.2 (1.1)	n/a	8	20	
GTX564RHK			Half Cube	526 (239)	450 (204)	6.3 (500)	13.1 (1.1)		7	20	

Use Model # GTX567AHK, GTX567AC, GTX567LHK, GTX567LC to indicate 220/50/1.

RC Condenser Series

Model Number	Description	Dimensions / inches (cm)			Gross Weight
		W	D	H	
RC214APV	Single-circuit vertical air flow remote condenser; vapor-charged with resealable quick-connect fittings, for GB/GT564R Cubers	40.75" (103.5cm) including interconnect fitting housing	22.75" (57.8cm)	30.2" (76.6cm) including 10" (25.4 cm) legs and fan guard	135lb (61.24kg)



1 1/4" x 1 1/4" x 1 1/4" 1 1/4" x 1 1/4" x 3/8"

IT'S NICE TO BE NOTICED™



X-SERIES

GTX360 – ICE MACHINE

THE X-SERIES IMPACT

Produces up to 300lbs of ice per day! The X-Series from Kold-Draft features rounded corners, plastic top panels, plastic louvers and an LCD display. X-Series machines are stackable with other X-Series machines. Double the capacity in the same footprint!

Dimensions/Weight				
Description	Dimensions / inches (cm)			Ship Weight
	W	D	H	
Air Cooled	30.1" (76.5cm)	25.7" (65.3cm)	16.9" (42.9cm)	175lb (79.3kg)
Liquid Cooled	30.1" (76.5cm)	25.7" (65.3cm)	16.9" (42.9cm)	175lb (79.3kg)

Recommended Operating Requirements:

	MIN.	MAX.
Room Air Temp.	45°F (7°C)	110°F (43°C)
Water Temp.	45°F (7°C)	90°F (32°C)
Voltage 208-230	198V	253V
Voltage 115	104V	126V
Potable Water Pressure	20 PSIG (137 kPa)	100 PSIG (689 kPa)
Liquid-Cooled Condenser Pressure	20 PSIG (137 kPa)	100 PSIG (689 kPa)

GTX360 Series Daily Capacities: Lbs. of ice per 24 hours per unit

Model Number	Electrical Volt/Hz/Ph	Condenser	Cube Size	Min. Ice Capacity 24 Hours lbs. (kg)		Max. Energy Input 90°F (32°C) 70°F (21°C) kWh/100 lbs. (kJ/kg)	Max. Water Use gal/100# (l/kg) 90°F (32°C) 70°F (21°C)		MCA	MOP	Required Condenser	
				70°F (21°C) 50°F (10°C) Ambient/ Water	90°F (32°C) 70°F (21°C) Ambient/ Water		Potable	Condenser				
GTX361AC	115/60/1	Air Cooled	Full Cube	352 (160)	282 (128)	6.5 (516)	25.9 (2.2)	n/a	12.0	15	n/a	
GTX361AHK			Half Cube	372 (169)	286 (130)	6.5 (516)	22.0 (1.8)		12.0	15		
GTX361LC		Liquid Cooled	Full Cube	358 (162)	304 (138)	5.2 (413)	19.5 (1.6)	170 (14.2)	11.1	15		
GTX361LHK			Half Cube	410 (186)	367 (166)	4.9 (389)	21.0 (1.8)	185 (15.4)	11.1	15		
GTX364AC		208-230/60/1	Air Cooled	Full Cube	357 (162)	310 (141)	6.2 (492)	21.3 (1.8)	n/a	6.5		15
GTX364AHK				Half Cube	389 (176)	317 (144)	6.3 (500)	21.3 (1.8)		6.5		15
GTX364LC	Liquid Cooled		Full Cube	349 (158)	295 (134)	5.2 (413)	19.3 (1.6)	168 (14.0)	6.0	15		
GTX364LHK			Half Cube	399 (181)	351 (159)	4.9 (389)	22.0 (1.8)	175 (14.6)	6.0	15		

Use Model # GTX367AHK, GTX367AC, GTX367LHK, GTX367LC to Indicate 220/50/1.

KOLD-DRAFT

ice Machines • bins • crushers • dispensers



SHOWN WITH KDB400

Plumbing:

- 3/4" FPT potable water inlet
- 3/4" FPT bin drain
- 3/4" I.D. flex tubing cuber drain
- 3/8" FPT condenser (liquid-cooled) inlet
- 1/2" FPT condenser (liquid-cooled) outlet

Exterior Finish:

300 Series stainless steel

Refrigeration System:

Thermostatic expansion valve controlled R-404A-HFC

Clearance Requirements:

Allow 4" left side, 8" right side and back, and 6" top for ventilation and utility connections.

Condenser Heat Rejection:

BTUH/kW/Ton
4,700/1.38/0.39 avg.
5,850/1.71/0.49 peak



1 1/4" x 1 1/4" x 1 1/4" | 1 1/4" x 1 1/4" x 3/8"

IT'S NICE TO BE NOTICED™



KOLD-DRAFT

ice Machines • bins • crushers • dispensers



SHOWN WITH KDB950

Plumbing:

- 3/4" FPT potable water inlet
- 3/4" FPT bin drain
- 3/4" I.D. flex tubing cuber drain
- 3/8" FPT condenser (liquid-cooled) inlet
- 1/2" FPT condenser (liquid-cooled) outlet

Exterior Finish:

300 Series stainless steel

Refrigeration System:

Thermostatic expansion valve controlled R-404A-HFC

Clearance Requirements:

Allow 4" left side, 8" right side and back, and 6" top for ventilation and utility connections.

Condenser Heat Rejection:

BTUH/kW/Ton
13,850/4.06/1.15 avg.
18,000/5.3/1.5 peak

GB1060 – ICE MACHINE

THE WORKHORSE

The KOLD-DRAFT GB1060 Workhorse Series produces up to 1,000lbs. of ice per day. The GB1060 is also stackable — allowing you to double the capacity in the same footprint.

Dimensions/Weight

Description	Dimensions / inches (cm)			Ship Weight
	W	D	H	
Air Cooled	42.3" (107.4cm)	31.1" (79cm)	33.7" (85cm)	360lb (163.3kg)
Liquid Cooled	42.3" (107.4cm)	25.7" (65.3cm)	33.7" (85cm)	320lb (145kg)
Remote Air Cooled	42.3" (107.4cm)	25.7" (65.3cm)	33.7" (85cm)	320lb (145kg)

Recommended Operating Requirements:

	MIN.	MAX.
Room Air Temp.	45°F (7°C)	110°F (43°C)
Water Temp.	45°F (7°C)	90°F (32°C)
Voltage 208-230	198V	253V
Potable Water Pressure	20 PSIG (137 kPa)	100 PSIG (689 kPa)
Liquid-Cooled Condenser Pressure	20 PSIG (137 kPa)	100 PSIG (689 kPa)

GB1060 Series Daily Capacities: Lbs. of ice per 24 hours per unit

Model Number	Electrical Volt/Hz/Ph	Condenser	Cube Size	Ice Capacity 24 Hours lbs. (kg)		Energy Input 90°F (32°C) 70°F (21°C)	Water Use gal/100# (l/kg)		MCA	MOP	Required Condenser	
				70°F (21°C) 50°F (10°C) Ambient/ Water	90°F (32°C) 70°F (21°C) Ambient/ Water		Potable	Condenser				
GB1064AC	208-230/60/1	Air Cooled	Full Cube	1075 (488)	860 (390)	4.9 (389)	12.9 (1.1)	n/a	11	20	n/a	
GB1064AHK			Half Cube	1066 (484)	881 (400)	4.9 (389)	13.0 (1.1)		11	20		
GB1064LC		Liquid Cooled	Full Cube	1047 (475)	918 (416)	4.1 (325)	16.4 (1.4)	174 (14.5)	10	20		
GB1064LHK			Half Cube	1089 (494)	931 (422)	4.1 (325)	15.3 (1.3)	157 (13.1)	10	20		
GB1064RC		Remote Air Cooled	Full Cube	959 (435)	767 (348)	5.3 (421)	12.6 (1.1)	n/a	11	25		RC314APV
GB1064RHK			Half Cube	1031 (468)	838 (380)	5.1 (405)	15.0 (1.3)		11	25		

Use Model # GB1067AHK, GB1067AC, GB1067LHK, GB1067LC, GB1067RHK, GB1067RC to Indicate 220/50/1.

RC Condenser Series

Model Number	Description	Dimensions / inches (cm)			Gross Weight
		W	D	H	
RC314APV	Single-circuit vertical air flow remote condenser; vapor-charged with resealable quick-connect fittings, for GB1064R Cubers	40.75" (103.5cm) including interconnect fitting housing	22.75" (57.8cm)	30.2" (76.6cm) including 10" (25.4 cm) legs and fan guard	140lb (63.5kg)



1 1/4" x 1 1/4" x 1 1/4" 1 1/4" x 1 1/4" x 3/8"

IT'S NICE TO BE NOTICED™



COMPONENT



GB560 – ICE MACHINE

THE SIGNATURE

The KOLD-DRAFT GB560 produces up to 500lbs. of ice per day. Stack it on another GB Series machine and increase the amount of ice harvested.

Dimensions/Weight				
Description	Dimensions / inches (cm)			Ship Weight
	W	D	H	
Air Cooled	42.3" (107.4cm)	31.1" (79cm)	17" (43.2cm)	215lb (97.5kg)
Liquid Cooled	42.3" (107.4cm)	25.63" (65.1cm)	17" (43.2cm)	200lb (90.7kg)
Remote	42.3" (107.4cm)	25.63" (65.1cm)	17" (43.2cm)	200lb (90.7kg)

Recommended Operating Requirements:

	MIN.	MAX.
Room Temp.	45°F (7°C)	110°F (43°C)
Water Temp.	45°F (7°C)	90°F (32°C)
Voltage 208-230	198V	253V
Voltage 115	104V	126V
Potable Water Pressure	20 PSIG (137 kPa)	100 PSIG (689 kPa)
Liquid-Cooled Condenser Pressure	20 PSIG (137 kPa)	100 PSIG (689 kPa)

GB560 Series Daily Capacities: Lbs. of ice per 24 hours per unit

Model Number	Electrical Volt/Hz/Ph	Condenser	Cube Size	Ice Capacity 24 Hours lbs. (kg)		Energy Input 90°F (32°C) 70°F (21°C) kWh/100 lbs. (kJ/kg)	Water Use gal/100# (l/kg) 90°F (32°C) / 70°F (21°C)		MCA	MOP	Required Condenser	
				70°F (21°C) 50°F (10°C) Ambient/Water	90°F (32°C) 70°F (21°C) Ambient/Water		Potable	Condenser				
GB561AC	115/60/1	Air Cooled	Full Cube	490 (222)	402 (182)	5.9 (468)	14.0 (1.2)	n/a	14	30	n/a	
GB561AHK			Half Cube	502 (228)	412 (187)	5.9 (468)	16.0 (1.3)		13	30		
GB561LC		Liquid Cooled	Full Cube	559 (254)	474 (215)	4.8 (381)	14.7 (1.2)	157 (13.1)	13	30		
GB561LHK			Half Cube	585 (265)	513 (233)	4.6 (365)	16.3 (1.4)	126 (10.5)	13	30		
GB564AC	208-230/60/1	Air Cooled	Full Cube	483 (219)	413 (187)	6.0 (476)	13.9 (1.2)	n/a	7	20		RC214APV
GB564AHK			Half Cube	542 (246)	448 (203)	5.8 (460)	16.8 (1.4)		7	20		
GB564LC		Liquid Cooled	Full Cube	543 (246)	456 (207)	4.9 (389)	14.0 (1.2)	162 (13.5)	7	20		
GB564LHK			Half Cube	598 (271)	522 (237)	4.7 (373)	14.7 (1.2)	181 (15.1)	7	20		
GB564RC		Remote Air Cooled	Full Cube	495 (225)	427 (194)	6.4 (508)	14.4 (1.2)	n/a	8	20		
GB564RHK			Half Cube	508 (230)	458 (208)	6.2 (492)	16.2 (1.4)		8	20		

Use Model # GB567AHK, GB567AC, GB567LHK, GB567LC to indicate 220/50/1.

RC Condenser Series

Model Number	Description	Dimensions / inches (cm)			Gross Weight
		W	D	H	
RC214APV	Single-circuit vertical air flow remote condenser, vapor-charged with re-sealable quick-connect fittings for GB/GT564R Cubers	40.75" (103.5cm) including interconnect fitting housing	22.75" (57.8cm)	30.2" (76.6cm) including 10" (25.4cm) legs and fan guard	135lb (62.4kg)

KOLD-DRAFT

ice Machines • bins • crushers • dispensers



SHOWN WITH KDB650

Plumbing:

- 3/4" FPT potable water inlet
- 3/4" FPT bin drain
- 3/4" I.D. flex tubing cuber drain
- 3/8" FPT condenser (liquid-cooled) inlet
- 1/2" FPT condenser (liquid-cooled) outlet

Exterior Finish:

300 Series stainless steel

Refrigeration System:

Thermostatic expansion valve controlled R-404A-HFC

Clearance Requirements:

Allow 4" left side, 8" right side and back, and 6" top for ventilation and utility connections.

Condenser Heat Rejection:

BTUH/kW/Ton
6,500/1.91/0.54 avg
8,750/2.6/0.729 peak



IT'S NICE TO BE NOTICED™



KOLD-DRAFT

ice Machines • bins • crushers • dispensers



SHOWN WITH KDB400

Plumbing:

- 3/4" FPT potable water inlet
- 3/4" FPT bin drain
- 3/4" I.D. flex tubing cuber drain
- 3/8" FPT condenser (liquid-cooled) inlet
- 1/2" FPT condenser (liquid-cooled) outlet

Exterior Finish:

300 Series stainless steel

Refrigeration System:

Thermostatic expansion valve controlled R-404A-HFC

Clearance Requirements:

Allow 4" left side, 8" right side and back, and 6" top for ventilation and utility connections.

Condenser Heat Rejection:

BTUH/kW/Ton
6,500/1.9/0.54 avg.
8,750/2.6/0.729 peak

GT560 – ICE MACHINE

THE CLASSIC

The KOLD-DRAFT GT560 produces up to 500lbs. of our exclusive FULL cube, and HALF cube. Known for their shape, purity, hardness and slower melt rate, our ice lasts longer in storage bins, ice coolers, cocktail sinks, drinks, salad bars and bags.

Dimensions/Weight				
Description	Dimensions / inches (cm)			Ship Weight
	W	D	H	
Air Cooled	30.1" (76.5cm)	25.7" (65.3cm)	30.7" (78cm)	225lb (163.2kg)
Liquid Cooled	30.1" (76.5cm)	25.7" (65.3cm)	30.7" (78cm)	220lb (99.8kg)
Remote	30.1" (76.5cm)	25.7" (65.3cm)	30.7" (78cm)	220lb (99.8kg)

Recommended Operating Requirements:

	MIN.	MAX.
Room Air Temp.	45°F (7°C)	110°F (43°C)
Water Temp.	45°F (7°C)	90°F (32°C)
Voltage 208-230	198V	253V
Voltage 115	104V	126V
Potable Water Pressure	20 PSIG (1.37 kPa)	100 PSIG (689 kPa)
Liquid-Cooled Condenser Pressure	20 PSIG (1.37 kPa)	100 PSIG (689 kPa)

GT560 Series Daily Capacities: Lbs. of ice per 24 hours per unit

Model Number	Electrical Volt/ Hz/Ph	Condenser	Cube Size	Ice Capacity 24 Hours lbs. (kg)		Energy Input 90°F (32°C) 70°F (21°C) kWh/100 lbs. (kJ/kg)	Water Use gal/100# (l/kg) 90°F (32°C) 70°F (21°C)		MCA	MOP	Required Condenser
				70°F (21°C) 50°F (10°C) Ambient/ Water	90°F (32°C) 70°F (21°C) Ambient/ Water		Potable	Condenser			
GT561AC	115/60/1	Air Cooled	Full Cube	525 (238)	424 (192)	5.8 (460)	16.0 (1.3)	n/a	14	30	n/a
GT561AHK			Half Cube	538 (244)	424 (192)	5.9 (468)	18.3 (1.5)	n/a	13	30	
GT561LC		Liquid Cooled	Full Cube	543 (246)	477 (216)	4.8 (381)	15.5 (1.3)	166 (13.9)	13	30	
GT561LHK			Half Cube	561 (254)	484 (220)	4.7 (373)	17.6 (1.5)	184 (15.4)	12	30	
GT564AC	208-230/60/1	Air Cooled	Full Cube	502 (228)	405 (184)	6.0 (476)	18.8 (1.6)	n/a	7	20	
GT564AHK			Half Cube	514 (233)	405 (184)	6.0 (476)	18.5 (1.5)	n/a	8	20	
GT564LC		Liquid Cooled	Full Cube	557 (253)	489 (222)	4.8 (381)	13.9 (1.2)	162 (13.5)	7	20	
GT564LHK			Half Cube	593 (269)	512 (232)	4.8 (381)	15.9 (1.3)	159 (13.3)	7	20	
GT564RC		Remote	Full Cube	496 (225)	413 (187)	6.5 (516)	13.2 (1.1)	n/a	8	20	
GT564RHK			Half Cube	526 (239)	450 (204)	6.3 (500)	13.1 (1.1)	n/a	7	20	

Use Model # GT567AHK, GT567AC, GT567LHK, GT567LC to Indicate 220/50/1.

RC Condenser Series

Model Number	Description	Dimensions / inches (cm)			Gross Weight
		W	D	H	
RC214APV	Single-circuit vertical air flow remote condenser; vapor-charged with resealable quick-connect fittings, for GB/GT564R Cubers	40.75" (103.5cm) including interconnect fitting housing	22.75" (57.8cm)	30.2" (76.6cm) including 10" (25.4 cm) legs and fan guard	135lb (61.24kg)



1 1/4" x 1 1/4" x 1 1/4" | 1 1/4" x 1 1/4" x 3/8"

IT'S NICE TO BE NOTICED™



GT360 – ICE MACHINE

THE IMPACT

Even if you don't need a ton of ice, you can still make a large impact with your customers. The KOLD-DRAFT GT360 produces up to 300lbs. of our exclusive FULL cube, and HALF cube ice.

Dimensions/Weight				
Description	Dimensions / inches (cm)			Ship Weight
	W	D	H	
Air Cooled	30.1" (76.5cm)	25.7" (65.3cm)	16.9" (42.9cm)	175lb (79.3kg)
Liquid Cooled	30.1" (76.5cm)	25.7" (65.3cm)	16.9" (42.9cm)	175lb (79.3kg)

Recommended Operating Requirements:

	MIN.	MAX.
Room Air Temp.	45°F (7°C)	110°F (43°C)
Water Temp.	45°F (7°C)	90°F (32°C)
Voltage 208-230	198V	253V
Voltage 115	104V	126V
Potable Water Pressure	20 PSIG (137 kPa)	100 PSIG (689 kPa)
Liquid-Cooled Condenser Pressure	20 PSIG (137 kPa)	100 PSIG (689 kPa)

GT360 Series Daily Capacities: Lbs. of ice per 24 hours per unit

Model Number	Electrical Volt/Hz/Ph	Condenser	Cube Size	Min. Ice Capacity 24 Hours lbs. (kg)		Max. Energy Input 90°F (32°C) 70°F (21°C)	Max. Water Use gal/100# (l/kg)		MCA	MOP	Required Condenser
				70°F (21°C) 50°F (10°C) Ambient/ Water	90°F (32°C) 70°F (21°C) Ambient/ Water		Potable	Condenser			
GT361AC	115/60/1	Air Cooled	Full Cube	352 (160)	282 (128)	6.5 (516)	25.9 (2.2)	n/a	12.0	15	n/a
GT361AHK			Half Cube	372 (169)	286 (130)	6.5 (516)	22.0 (1.8)				
GT361LC		Liquid Cooled	Full Cube	358 (162)	304 (138)	5.2 (413)	19.5 (1.6)	170 (14.2)	11.1	15	
GT361LHK			Half Cube	410 (186)	367 (166)	4.9 (389)	21.0 (1.8)	185 (15.4)	11.1	15	
GT364AC	208-230/60/1	Air Cooled	Full Cube	357 (162)	310 (141)	6.2 (492)	21.3 (1.8)	n/a	6.5	15	
GT364AHK			Half Cube	389 (176)	317 (144)	6.3 (500)	21.3 (1.8)				
GT364LC		Liquid Cooled	Full Cube	349 (158)	295 (134)	5.2 (413)	19.3 (1.6)	168 (14.0)	6.0	15	
GT364LHK			Half Cube	399 (181)	351 (159)	4.9 (389)	22.0 (1.8)	175 (14.6)	6.0	15	

Use Model # GT367AHK, GT367AC, GT367LHK, GT367LC to Indicate 220/50/1.

KOLD-DRAFT

ice Machines • bins • crushers • dispensers



SHOWN WITH KDB400

Plumbing:

- 3/4" FPT potable water inlet
- 3/4" FPT bin drain
- 3/4" I.D. flex tubing cuber drain
- 3/8" FPT condenser (liquid-cooled) inlet
- 1/2" FPT condenser (liquid-cooled) outlet

Exterior Finish:

300 Series stainless steel

Refrigeration System:

Thermostatic expansion valve controlled R-404A-HFC

Clearance Requirements:

Allow 4" left side, 8" right side and back, and 6" top for ventilation and utility connections.

Condenser Heat Rejection:

BTUH/kW/Ton
4,700/1.38/0.39 avg.
5,850/1.71/0.49 peak

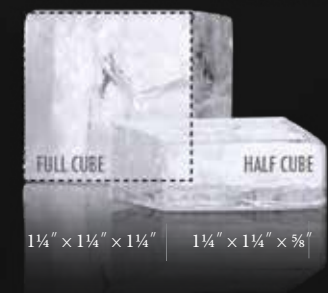

IT'S NICE TO BE NOTICED™



KOLD-DRAFT

ice Machines • bins • crushers • dispensers



HD200 Series
(Shown with optional Ice Maker)

Exterior Finish:

304 Series Stainless Steel Exterior corrosion resistance, and long life.

Interior Finish:

Urethane Foam Insulated Cabinet

Available with 90° corners (HD201, HD204, HD207) or rounded corners (HDX201, HDX204, HDX207)

Clearance Requirements:

Please see ice machine recommendations.

Large Sink Accommodates Most Hotel Ice Buckets

Dual voltage, 50/60 Hz. motor.
1/3 HP capacitor start energy saver motor.

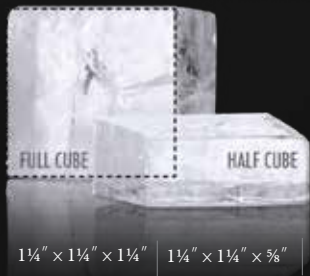

1 1/4" x 1 1/4" x 1 1/4" | 1 1/4" x 1 1/4" x 5/8"

IT'S NICE TO BE NOTICED™

HD200 / HDX200 SERIES ICE DISPENSERS

THE DISPENSER

Kold-Draft Ice Dispensers deliver a high-capacity storage and easy to use ice dispenser solution. The HD200 & HDX200 series will fit any Kold-Draft 30" modular ice maker. These dispensers feature easy to use push button operation and a lift wheel agitation/dispensing system to prevent ice clumping.

HD201 / HDX201 Series Ice Dispensers Specifications

Model Number	Electrical Volt/ Hz/Ph	MCA	MOP	Storage Capacity	Corner Style	Operating Temperature Range	Operation	Drain	Dimensions (Including Legs) In (mm)	Shipping Weight
HD201	115/60/1	2.1A	15A	190 lb (86.2 kg)	90°	45°F – 90°F (7°C – 32°C)	Push Button	1/2" IPS	30" x 32.3" x 53" (762 x 820 x 1346)	230 lb 104 kg
HD204	208-230/60/1	1.2A	15A	190 lb (86.2 kg)	90°	45°F – 90°F (7°C – 32°C)	Push Button	1/2" IPS	30" x 32.3" x 53" (762 x 820 x 1346)	230 lb 104 kg
HD207	220/50/1	1.2A	15A	190 lb (86.2 kg)	90°	45°F – 90°F (7°C – 32°C)	Push Button	1/2" IPS	30" x 32.3" x 53" (762 x 820 x 1346)	230 lb 104 kg
HDX201	115/60/1	2.1A	15A	190 lb (86.2 kg)	90°	45°F – 90°F (7°C – 32°C)	Push Button	1/2" IPS	30" x 32.3" x 53" (762 x 820 x 1346)	230 lb 104 kg
HDX204	208-230/60/1	1.2A	15A	208-230/60/1	90°	45°F – 90°F (7°C – 32°C)	Push Button	1/2" IPS	30" x 32.3" x 53" (762 x 820 x 1346)	230 lb 104 kg
HDX207	220/50/1	1.2A	15A	190 lb (86.2 kg)	90°	45°F – 90°F (7°C – 32°C)	Push Button	1/2" IPS	30" x 32.3" x 53" (762 x 820 x 1346)	230 lb 104 kg

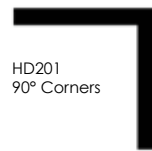

HD201
90° Corners



HDX201
Rounded
Corners



COMPONENT



T280 SERIES – ICE CRUSHER

THE BIG CRUSH

KOLD-DRAFT crushed ice is superior to flaked ice. Our T280 crushed ice is made from harder, denser cubes, so it lasts longer and melts slower than flaked ice.

Dimensions/Weight				
Description	Dimensions / inches (cm)			Ship Weight
	W	D	H	
T280	42.3" (107.4cm)	25.5" (64.7cm)	15.5" (39.4cm)	150lb (68kg)

General Specifications for T281 and T284						
Model Number	Voltage (V/HZ/PH)	Number of Wires	MCA	MOP	Operating Range	Use with Models
*T281	115/50-60/1	2	7.2	15	104-126V	GB561
*T284	208-230/50-60/1	2	4.1	15	198-253V	GB564/GB1064

*Models are for GB560 and GB1060 Series Energy Efficient Models.

We reserve the right to make product improvements at any time. Specifications and design are subject to change without notice.

Note: Always disconnect power before cleaning or servicing equipment. Automatic motor operation when used with **KOLD-DRAFT GB Series Ice Machines**. Pre-wired to operate with either one or two **KOLD-DRAFT GB Series Ice Machines**.

KOLD-DRAFT

Ice Machines • bins • crushers • dispensers



SHOWN WITH KDB650

Exterior Finish:

Stainless steel cabinet, crusher mechanism, and hopper for cleanliness, corrosion resistance, and long life.

Clearance Requirements:

Please see ice machine recommendations.

Crusher mechanism has ball bearings for durability.

Dual voltage, 50/60 Hz. motor. 1/3 HP capacitor start energy saver motor.

Provides for crushed and cubed ice when used with a divided bin.

Safety interlock provided to prevent operation of crusher when panels are removed.

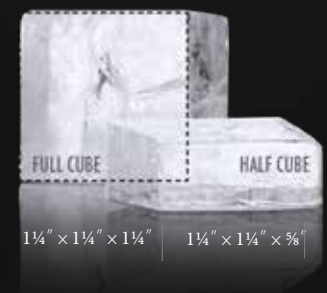

1 1/4" x 1 1/4" x 1 1/4"

1 1/4" x 1 1/4" x 5/8"

IT'S NICE TO BE NOTICED™



KOLD-DRAFT

Ice Machines • bins • crushers • dispensers



COCKTAIL SERIES ICE MACHINES

COCKTAIL SERIES - KD-110, KD-70, KD-50

The KOLD-DRAFT Cocktail Series of Ice Machines provides consumers with a top-shelf choice for ice that matches their top-shelf beverage. The KOLD-DRAFT Cocktail Series produces a Large Cube measuring 1.19" x 1.38" x 1.3". The KOLD-DRAFT Cocktail Series consists of three machines with daily ice production of 50lbs, 70lbs or 110 lbs. KOLD-DRAFT equipment offers some of the best recovery rates in the industry, too. You get more ice, more often.

Dimensions/Weight (with 6" legs)

	Ice Storage Capacity	Unit Dimensions / inches (cm)			Shipping Weight
		W	D	H	
KD-110	60 lb	24.8" (62.99cm)	20.7" (52.58cm)	36.7" (93.21cm)	130 lb (59kg)
KD-70	40 lb	19.7" (50.03cm)	17" (43.18cm)	36.7" (93.21cm)	110 lb (50kg)
KD-50	26 lb	15.5" (39.37cm)	17.7" (44.95cm)	36.7" (93.21cm)	102 lb (43kg)

Recommended Operating Requirements:

	MIN.	MAX.
Room Temp.	45°F (7°C)	90°F (32°C)
Water Temp.	45°F (7°C)	90°F (32°C)
Voltage 115	104V	126V
Potable Water Pressure	5 PSIG (0.034 MPA)	100 PSIG (0.6 MPA)

Cocktail Series Daily Capacities: Lbs. of ice per 24 hours per unit

Model Number	Electrical Volt/Hz/Ph	Condenser	Cube Size	Ice Capacity 24 Hours lbs. (kg)		Energy Input 90°F/70°F kWh/100# (kJ/kg)	Tier	Water Use gal/100# (l/kg) 90°F/70°F		MCA	MOP
				70°F (21°C) / 50°F (10°C) Ambient/Water	90°F (32°C) / 70°F (21°C) Ambient/Water			Potable	Condenser		
KD-110	115/60/1	Air Cooled	Large	118 (53.5)	107 (48.5)	8.9 (738.1)	I	15.89 (1.1)	n/a	7	15
KD-70				82 (37.2)	73 (33.11)	9.2 (761.9)		21.67 (1.8)		5	
KD-50				59 (26.7)	43 (19.5)	12.9 (1023.8)		20.11 (1.7)		5	

Plumbing:
1/4" water line
3/4" drain line

Exterior Finish:
300 Series stainless steel

Refrigeration System:
Refrigerant is R134A

Clearance Requirements:
Front must be completely unobstructed, at least 4" of clearance on the back, and 0.6" clearance for the top and sides.



1.19" x 1.38" x 1.3"

IT'S NICE TO BE NOTICED™

Large Cube:

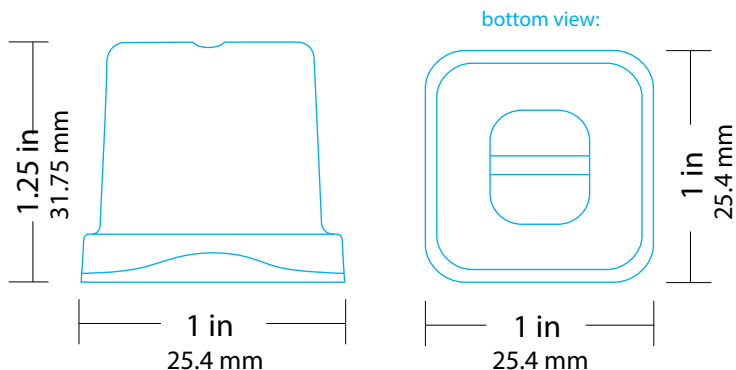

SC200 SERIES – SELF CONTAINED ICE MACHINE

THE KOLD-DRAFT SC200

The KOLD-DRAFT SC200 produces up to 200 lbs. of full cube ice per day. The SC200 is ideal for any undercounter or bar application. The front breathing inlet and discharge allows for installation in tight spaces.

Dimensions/Weight				
Description	Dimensions / inches (cm)			Ship Weight
	W	D	H	
Air Cooled (without legs)	26" (66cm)	28.6" (72.6cm)	31.4" (79.8cm)	185lb (84kg)
With Legs	26" (66cm)	28.6" (72.6cm)	37.4" (100cm)	185lb (84kg)

Recommended Operating Requirements:

	MIN.	MAX.
Room Temp.	45°F (7°C)	90°F (32°C)
Water Temp.	45°F (7°C)	90°F (32°C)
Voltage 220-240	210	250
Voltage 115	104	126
Potable Water Pressure	5 PSIG (0.034 MPA)	100 PSIG (0.6 MPA)

SC200 Series Daily Capacities: Lbs. of ice per 24 hours per unit

Model Number	Electrical Volt/Hz/Ph	Condenser	Cube Size	Ice Capacity 24 Hours lbs. (kg)		Energy Input 90°F/70°F kWh/100# (kJ/kg)	Tier	Water Use gal/100# (l/kg) 90°F/70°F		MCA	MOP
				70°F (21°C) / 50°F (10°C) Ambien/Water	90°F (32°C) / 70°F (21°C) Ambien/Water			Potable	Condenser		
SC201AC	115/60/1	Air Cooled	Full Cube	150 (68.04)	119 (53.98)	8.71 (691.28)	1	29.56 (2.47)	n/a	6	15
SC207AC	220-240/50/1	Air Cooled	Full Cube	149 (67.59)	118 (53.52)	8.25 (654.77)	1	29.34 (2.45)	n/a	3	15

KOLD-DRAFT

Ice Machines • bins • crushers • dispensers



SC200 SERIES
SELF CONTAINED
ICE MACHINE

Features:

- Produces up to 200 lbs. of full cube ice per day.
- Ideal for any undercounter or bar application.
- Front breathing inlet and discharge allows installation in tight spaces.
- Front access to ice. Door lifts up or slides in, so it's out of the way.
- Electroless nickel plated evaporator.
- Corrosion-resistant stainless steel exterior with plastic door and bin liner.
- Stores 125 lbs. of ice.

Plumbing:

- 1/2" FIP potable water inlet
- 3/4" FIP ice bin drain
- 1/2" FIP ice maker drain
- .88" Diameter electrical connection

Exterior Finish:

Corrosion-resistant stainless steel exterior with plastic door and bin liner



1 1/4" x 1 1/4" x 1 1/4"



IT'S NICE TO BE NOTICED™

Features:

- Stainless Steel exterior.
- Rigid stainless steel lift doors withstand heavy use.
- A gasket seals the door opening to reduce ice meltage.
- Non-corroding polyethylene lined walls eliminate pitting and staining.
- Easy cleaning.
- Non-CFC polyurethane foam insulation bonds the shell and linin.
- Extra-large door openings provide maximum access for ice removal and bin cleaning.
- Low door sills allow users to easily reach ice at the bottom of the bin.

ICE BINS



KDB230

- Match with the GT360 Series
- Storage capacity 230 lbs / 104 kg



KDB400

- Match with the GT360 or GT560 Series
- Storage capacity 400 lbs / 181 kg



KDB650

- Match with the GB560 or GB1060 Series
- Storage capacity 660 lbs / 299 kg



KDB950

- Match with the GB1060 or GB560 Series
- Storage capacity 950 lbs / 431 kg

General Specifications for KDB230/KDB400/KDB650/KDB950

Model	Dimensions / inches (cm)			Ice Capacity lb (kg)	Shipping Weight lb (kg)
	W	D	H <small>WITH 6" LEGS</small>		
KDB230	30.25" (76.8cm)	34" (86.4cm)	23" (58.4cm)	230lb (104kg)	110lb (50kg)
KDB400	30.25" (76.8cm)	34" (86.4cm)	37" (94cm)	400lb (181kg)	140lb (64kg)
KDB650	42" (106.6cm)	35" (88.9cm)	41" (104.1cm)	660lb (181kg)	190lb (86kg)
KDB950	48" (121.9cm)	31.75" (80.6cm)	50" (127cm)	950lb (431kg)	220lb (100kg)



Ice Machines
Dispensers
Crushers
Bins

KOLD-DRAFT®

ice Machines • bins • crushers • dispensers