



**GYROCOPTERS**

# RIZZ FOLDABLE EBIKE INSTRUCTION

Do not use this product without carefully reading this instruction manual  
and understanding the performance of electric bicycles  
Please keep the instruction manual properly

# HELMETS SAVE LIVES!

Always wear a properly fitted helmet that complies with CPSC or CE safety standards when you ride your Gyrocopters Rizz Ebike



**Correct Fitting:**  
Make sure your helmet covers your forehead.



**Incorrect Fitting:**  
Forehead is exposed and vulnerable to serious injury.

## Instructions For Gyrocopters Rizz Ebike

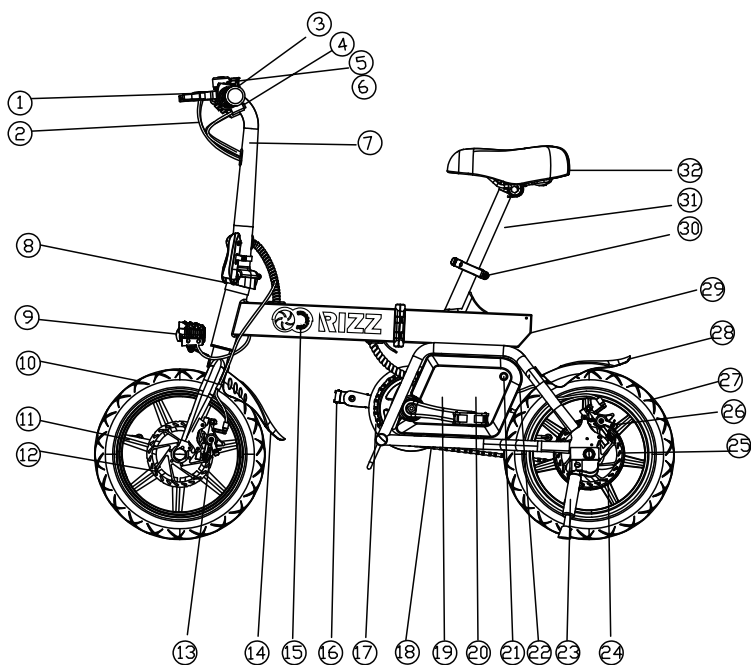

- |                            |                     |
|----------------------------|---------------------|
| 1. Brake lever             | 17. Chainring       |
| 2. Wiring harness          | 18. Chain           |
| 3. Grips                   | 19. Controller      |
| 4. Power switch/Button     | 20. Battery         |
| 5. Bell                    | 21. Charging port   |
| 6. Instrument/light button | 22. Battery box     |
| 7. Riser                   | 23. Parking rack    |
| 8. Front fork headset      | 24. Motor           |
| 9. Headlight               | 25. Disc brake pad  |
| 10. Tire                   | 26. Disc brake      |
| 11. Wheel                  | 27. Tire            |
| 12. Disc brake pad         | 28. Rear fender     |
| 13. Disc brake             | 29. Taillight       |
| 14. Front fender           | 30. Seat post clamp |
| 15. Frame                  | 31. Seat post       |
| 16. Pedal                  | 32. Seat            |

## Product Parameters

Build	Model	Rizz
	Body material	Iron frame
	Folded size	1215*230*580mm
	Expanded size	1215*475*1020mm
	Packing size	1215*210*600mm
	Wheelbase	840 mm
	Pedal ground clearance	120 mm
	Wheel hub	14 inches
	Body color	Black
Performance	Weight	20KG
	Load	120KG
	Average speed	20 km/h
	Max speed	25 km/h
	Power consumption per hundred kilometers	1.08 kWh
	Hill climbing capacity	15 degrees
	Operating temperature	-10~45 degrees Celsius
	IP rating	IP54

### Remark:

The maximum speed of the e-bike is influenced by various factors, including power, load, tire pressure, road conditions, chain, lubrication level, riding habits, temperature, and more.

## Product Parameters

Core	Model	Rizz
	Battery type	18650 lithium-ion
	Battery capacity	5.2AH
	Battery rated voltage	36V
	Charging voltage	DC42V
	Charger input voltage	AC100-240V
	Charging time	3-4H
	Motor type	Brushless DC motor
	Motor rated power	350W
	Motor rated voltage	36V
	Controller under voltage value	31V
	Controller over current value	15A
Features	Headlight	Yes
	Taillight	Yes
	Cruise	Yes
	Speed sensor	Yes
	Adjustable seat height	Yes
	Brakes	Front and rear disc brakes
	Modes	Pedal Assist / Throttle / Regular

### Remark:

The maximum speed of the e-bike is influenced by various factors, including power, load, tire pressure, road conditions, chain, lubrication level, riding habits, temperature, and more.

# Riding preparation

## 1. Read this instruction carefully to know the product performance and requests.

- 1)Check the tire pressure: Whether the pressure is sufficient. In case of insufficient tire pressure, the tire requires to be inflated to the normal state; Whether the tire lace is overly worn, or the tire surface is overly damaged or cracked, the new tire should be replaced immediately to the relevant maintenance place to prevent the vehicle from skidding on the wet or smooth road.
- 2)Check the circuit system: Battery power should be always sufficient to support the completion of your required mileage. Charge it first if the battery is not enough. Check if the dashboard (non standard configuration,) of the digital tube and battery indicator light work normal, if there is a fault, eliminate it first for maintenance.
- 3)Check the brake system: Check whether the power function of the brake is normal or not If the brake power failure function is invalid, please do not use it. Please send it to the relevant maintenance place in time for maintenance.
- 4)Check other items: Make sure that the entire vehicle's (mainly front and back wheel) screws are tight; the handlebar is adjusted well; the wheel lock has been opened; the foot has been put in place; the quick dismantling folding device is fine , and the safety buckle is in place.

## 2. Warning

- 1)During driving on an uphill surface, adverse wind and bad road conditions, manpower should be used to assist power riding to reduce the battery load.
- 2)If there is any kind of abnormal condition during the riding, emergency brake should be made on both front and rear brake, and the power switch should be turned off immediately. Continue ridding only after ensuring that the vehicle is in normal condition.
- 3)Gyrocopters Rizz Ebike is comfortable water and snow but it should not be miss leaded to be completely soaked in water. The wading depth should not exceed the lower edge of the motor hub or it would cause internal leakage of the motor hub.
- 4)For your safety and others, please ride on the non motorized lane, and do not carry people while obeying the traffic rules.
- 5)Before driving your Gyrocopters Rizz Ebike as a newbie, you should thoroughly understand the performance of the electric vehicle.
- 6)Do not drive with motor vehicles or drive too close to automobiles. Avoid driving into the blind spot area of motor vehicle drivers.

Note: Turn off the power while parked to save electricity



## 3. Brake

- 1)When you have to use the brake while driving, stop pedaling first and then use the brakes. .
- 2)Brake rear wheel first, then brake front wheel.
- 3)When the emergency brake is needed, the front and rear brake should be used at the same time because the braking effect will be reduced if using alone.

### Note:

- 1)While braking, speeding or turning, you must be very careful. Try not to increase the manpower at this time.
- 2)Drive at a slower speed and leave a enough distance for others.
- 3)Pay more attention to slippery and smooth road, and keep enough brake distance.

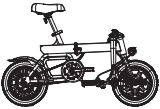
#### 4.Folding ( Follow the folding method)

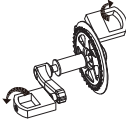
<b>Folding Steps:</b>			<b>Install Pedals :</b>
			
1.Expand diagram	2.Adjust the handle, loosen the handle of the folding riser and fold the lower riser.	3.Adjust the seat tube height,open the frame folding handle and fold the frame.	Right Pedal: Rotating Clockwise Left Pedal: Rotating Anticlockwise

#### 5.Parking

- 1)When you get off the Gyrocopters Rizz Ebike, you should turn off the power switch to ensure the service life of batteries, motors and electrical switches as well as to prevent accidents.
- 2)When open the kickstand, it' s recommended to park the vehicle in a spacious place. When temporarily parking is made , please use the safety lock to lock the vehicle (the safety lock is not provided as the accessories).
- 3)Do not park your Ebike in the building hall, evacuation staircase, safety exit and follow the safety code of a park correctly.

## Maintenance

#### 1.About the charger

- 1)When charging, please use factory designated special charger it should not be charged in the residential buildings, and place it where the children can not touch safe.
- 2)Pay attention to the charger plug when the charger is used, so as to avoid damaging the plug and causing poor input or output. At the same time, pay attention to assure it is moistureproof and waterproof.
- 3)The charger is not allowed to be used in unstable, excessive oil fumes and dust, humid, direct sunlight environment do not connect electrical appliances while their is lightning and maintain good ventilation conditions.
- 4)While using and storage of the charger, pay attention to avoid external objects entering, strictly prohibit any liquid or metal and other objects into the charger, so as to avoid the internal short circuit of the charger Beware of an impact or a violent shock.
- 5)There is a high voltage inside the charger Please do not open it without professionals. Please do not change the plug and wire of the charger by yourself
- 6)The charger should not be carried in the car when possible. If it is necessary to carry it, it should be placed in the toolbox after the shock absorption is done well, and the device in the charger should not be dismantled or replaced by yourself.

#### 2. Charging process

- 1)While charging, put the charger in the ventilation place first, then plug the charger outlet into the charging hole, then plug the charger into the electricity .
- 2)When Indicator changes from red to green, it indicates that battery charge is full. It should be recharged for 1-2 hours to ensure that the battery is fully charged. The longest time should not exceed 6 hours.
- 3)After charging, the input plug of the charger should be unplugged and then the output plug should be connected to the Gyrocopters Rizz Ebike.It is forbidden to connect the charger to the electric power outlet for a long time without charging. If you smell the odor in the charging process or find the charger temperature is too high, please stop charging immediately and send it back to the maintenance department to repair it.

### 3. About the battery (Non professionals shouldn't dismantle it)

1) Between the limit of 0 degree ~ 45 degree, the battery is charged; Between -20 degree ~ 60 degree discharge, keeping the battery dry and strictly forbidden to put the battery in the acid and alkaline liquid, avoiding the rain, away from the fire source, the heat source and the high temperature environment. It is strictly forbidden to reverse the positive and negative electrodes of the battery. It is strictly prohibited to destroy, disassemble the battery or make the battery short circuited. When charging, please use the original special charger. charging should not be more than 6 hours, the charging current is not more than 2A. In the long run, please keep the battery in the cool and dry place, and charge the battery for five hours a month. When charging, the battery must be handled according to the instructions. Otherwise, the user will be responsible for the result.

2) The newly purchased Gyrocopters Rizz Ebike may not be ready to ride so please charge then ride the bike.

3) Users must charge according to the requirements of the instructions when charging, otherwise the consequences will be concealed. Pay attention to the battery type and applicable voltage charged by the charger, and strictly prohibit mixing. When charging, it should be placed in a ventilated environment. It is strictly prohibited to recharge in residential buildings, confined space or hot weather.

4) When the vehicle is folded, the two metal contacts on the battery box end can not touch at the same time, which will result an accident caused by the short circuit of the battery.

5) Batteries should not be stored or used under high temperature for more than 60C in the sun. If you don't need it for a long time, please charge the battery once a month and charge it to half full at a time.

6) Strictly prohibit the battery to get soaked in water.

### 4. About the motor

Attention should be paid for protecting motor outlet to avoid short circuit of motor line wear and burning motor. At the same time, attention should be paid to avoid motor immersion in water for long time.

### 5. About the controller

Attention should be paid to the protection of the exposed wires of the vehicle, so as to avoid causing the shortcircuit burn out of the controller, and strictly prohibit the flushing of the controller with water.

## Notice

1) You must wear helmets, gloves, kneecap and elbow protectors before riding.

2) It is best to ride at medium speed. Do not continue pedaling when slowing down.

3) It is not allowed to ride on motorways, pedestrians and steep slopes. (climbing gradient should be less than 20 degrees)

4) It is not allowed to ride over the maximum weight of the body as mentioned. (maximum load 120KG)

5) It is not allowed to use in extremely hot and cold environment It is not suitable to ride on a bumpy wet road.

6) Strictly prohibit to be used by children under 16 years of age. Illegal use may encounter many unexpected dangers. The company does not undertake any liability of damage to life or personal injury and property damage when not following this manual.

## Declaration of responsibility

The company has the right to amend the product type, specification or related information mentioned in the manual and reserve the final interpretation right.

1) The specific type of functions mentioned in this manual is applicable to this particular type only.

2) Any changes or changes in the product type, the specification or related information mentioned in this manual will not notice the user.

3) Without the written permission of the company, no copy, modification, retransmission, dissemination or release of the version manual shall be made in any form.

4) Please read the handbook carefully before using the product and operate it in accordance with the manual. Otherwise, the company is not responsible for the damage of the products caused by improper use or error or the loss of personal and property.

5) For product related information, please inquire on Gyrocopters.ca



## Weight and Speed Limitations

Speed and weight limits are set for your own safety. Please do not exceed the limits listed in the "Specifications" section of this manual.

### **WARNING**

Overweight exertion on the device may increase possibility of injury or product damage.

## OPERATING RANGE

The following are some of the major factors that will affect the operating range of your device.

- 1) **Terrain:** Riding distance is highest when riding on a smooth, flat surface. Riding uphill and/or on rough terrain will reduce distance significantly.
- 2) **Weight:** A lighter user will have further range than a heavier user.
- 3) **Ambient temperature:** Please ride and store the device under recommended temperatures, which will increase driving distance; battery life, and overall performance of your device.
- 4) **Speed and Riding Style:** Maintaining a moderate and consistent speed while riding produces maximum distance. Traveling at high speeds for extended periods, frequent starts and stops, idling and frequent acceleration or deceleration will decrease overall distance.

\*Do not attempt to stop suddenly as this may lead to injury or damage to your brake discs.

### **WARNING**

Proper use of your brake is vital to ensure safe, efficient stopping. To avoid misuse and potential injury, do not apply sudden or excessive force to your brake. Apply the brake gradually and give yourself enough room to come to a complete stop safely.

Please follow all local, state and federal laws in regards to recycling, handling and disposing of Lead-acid battery.

## **WARNING**

**SEEK IMMEDIATE MEDICAL ASSISTANCE IF YOU ARE EXPOSED TO ANY SUBSTANCE THAT IS EMITTED FROM THE BATTERY.**

## **SAFETY ALERTS**

While riding your Gyrocopters Rizz Ebike, if there is a system error or illegal operation performed the device will prompt the user in a variety of ways.

The following are common occurrences where you will see Safety Alerts. These notices should not be ignored, but appropriate action should be taken to correct any illegal operation, failure or errors.

- Prohibited riding surfaces (uneven, too steep, unsafe, etc.)
- Battery voltage is too low.
- The device is still charging.
- Overheating, or motor temperature is too high.
- When the battery is about to run out of power, the battery icon will flash.
- If any or both tires are blocked, the device will stop after 10 seconds.
- When the battery level has depleted below protection mode, the device motor will power off after 15 seconds.

While sustaining a high discharge current during use (such as riding up a steep slope for a long period of time), the device motor will power off after 15 seconds.

## **WARRANTY**

Manufacturer warranty does not cover any physical/accidental damage due to improper usage. The warranty does not cover normal wear and tear, wheel, fender, or any other physical damage or water/liquid damage to your parts and unit.

For warranty information,

Please visit us at [www.gyrocopters.ca](http://www.gyrocopters.ca) or [www.imgadgets.com](http://www.imgadgets.com)

email us at [customer care@gyrocopters.ca](mailto:customer care@gyrocopters.ca) or [customer care@imgadgets.com](mailto:customer care@imgadgets.com)



GYROCOPTERS.CA

Website [Gyrocopters.ca](http://Gyrocopters.ca)

Phone: 6478461064

Address: 11-2340 Meadowvale Blvd, Mississauga, Ontario, Canada