

Packing Contents

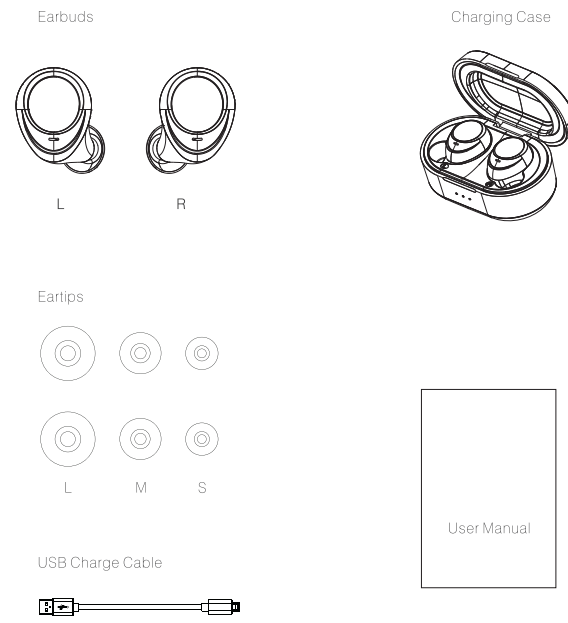

Technical Specification:

Earphone Type: TWS Earbuds
 Bluetooth Version: V5.0
 Bluetooth Chipset: RealTek
 Bluetooth Profile: HSP, HFP, A2DP, AVRCP
 Support decoder: SBC, AAC
 Auto ON/OFF: Yes by magnetic switch
 Auto Pairing: Yes, take out from case
 Stereo: Talk & Music
 Touch Sensor: Yes
 Operating range: 10M
 Frequency Range: 2.4GHz-2.48GHz
 Pairing Code: 0000 (1 device request)
 Frequency Response: 50Hz-20KHz
 Driver: Dynamic 6mm graphene driver
 Speaker impedance: 32Ω ± 15%
 Rated Power: 3mW
 THD+N: ≤ 1% @ 200Hz ~ 3 KHz
 Sensitivity: 96dB (±3dB) @ 1 KHz, 128mV
 Battery: Li-Polymer 500mAh Charging Case + 75mAh X 2 earbuds
 Battery cycle: >300 cycles
 Talk time: Up to 8 hours* + 25 hours with charging case
 Music playing time: up to 8 hours* + 25 hours with charging case
 Standby time: up to 100 hours*
 Mic. Sensitivity: -42dB ± 3dB (0dB=1V/Pa @ 1 KHz)
 Mic. THD+N: ≤ 2%
 Ear earplugs: Hybrid Silicone Bullet Type L, M, S Size
 Working Voltage: 3.7V
 Charging Voltage: 5V for charging case
 Charging Current: 900mA for Charging case, 50mA for earbuds
 Charging port: Micro-USB
 Charging time: 1.5 hours fully charged the case
 N.W.: 5.8g/earbud, 70g including charging case
 Earbud Dimensions: 23*19*13mm
 Charging Case Dimensions: 65*40*31mm (HWD)
 Operation: -10℃-40℃, 90% Relative humidity

FAQ

IMGadgets Wave Buds cannot pair with mobile device or just one earbud has sound?
 Ans: Please check whether your headset is in pairing mode and if the Bluetooth function on your device is on. If repairing is needed, please follow below steps:
 1. Delete the connected Bluetooth name by selecting "Forget this device" from your Bluetooth enabled device
 2. Open the charging case and put back the two earbuds inside the charging case
 3. Press and hold the back of both earbuds with two different fingers for 8-10 seconds until the red lights flash 3 times
 4. Then you can take out the earbuds to re-pair with your Bluetooth device to use
 Keep one thing in mind. Top part of the buds (touch sensors) are very sensitive to touch. Please ensure not to hold the buds right from the top or else without knowing you might be unpairing them if you hold it for a few seconds.

IMGadgets Wave Buds headset cannot be switched on?
 Ans: Please check the battery status of your headset as well as the charging case's battery. Don't forget to remove the seal sticker from each earbud on the first use.

Can I change the battery for the headset?
 Ans: No, this headset has a built-in non-detachable Li-Polymer battery, it cannot be removed.

IMGadgets Wave Buds has disconnected with my cellphone within 10 meters?
 Ans: Please check if there is metal or other material within a relatively close range which may interfere with the Bluetooth connection. Bluetooth is a radio technology which is sensitive to objects between the earbud and the connected device.

Why could I not charge the charging case and earbuds?
 Ans: Check if the terminal is plugged in tightly. If it is, try to use another new charging cable as well as seeing if the seal sticker on earbuds' charging pins have been removed.

Why do the earbuds power off automatically?
 Ans: After being powered on without any connection to a phone or Bluetooth device for 5 minutes, the earbuds will automatically turn off. Please reconnect the earbuds if this occurs.

Why aren't the touch sensors working?
 Ans: We recommend to operate IMGadgets Wave Buds under iOS8 & Android 4.3 or above. Please check that the volume on your device is turned up.

Safety Rules

- 1) Please follow the rules depicted in this manual closely to ensure your safety. Before using this TWS Stereo Headphone, we would strongly encourage you to read through this user manual.
- 2) Be more wary of any edges, uneven surfaces, metal parts, accessories and its packaging so as to prevent any possible injury or damage.
- 3) Do not modify, repair or dismantle this TWS Stereo Headsets. Doing so may result in fires, electric shocks, complete breakdown of this TWS Stereo Headsets, etc. All of which, are not covered under warranty.
- 4) Do not use any diluents or volatile liquid to clean the TWS Stereo Headsets.
- 5) Do not use the TWS Stereo Headsets in a hazardous location.

Service and Support
 If you have any issues with the device, please contact IMGadgets Support Team at support@imgadgets.com for assistance.

WAVE BUDS

- | Touch Sensor
- | Stereo Call & Music
- | AUTO ON/OFF
- | AUTO Pairing

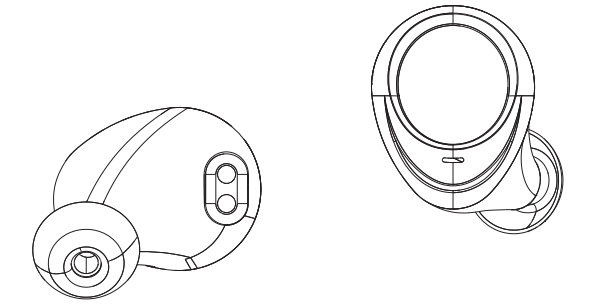

WAVE BUDS TWS Earbuds Quick Start Guide

1 / POWER ON & Pairing

Option 1: Auto On and Pairing
 With the two earbuds in the case, open the lid to power on.
 Take out the earbuds and wait about 10 seconds until (L)&(R) earbuds are paired automatically.

Option 2: Manually On and Pairing
 1. Delete the connected Bluetooth name by selecting "Forget this device" from your Bluetooth enabled device
 2. Open the charging case and put back the two earbuds inside the charging case
 3. Press and hold the back of both earbuds with two different fingers for 8-10 seconds until the red lights flash 3 times.
 4. Then you can take out the earbuds to re-pair with your Bluetooth device to use
 Keep one thing in mind. Top part of the buds (touch sensors) are very sensitive to touch. Please ensure not to hold the buds right from the top or else without knowing you might be unpairing them if you hold it for a few seconds.

2 / Turn on Bluetooth® (iOS/ Android/ Others)

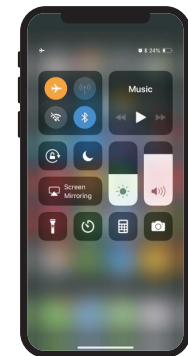

iOS
 Apple iOS
 Go to settings > Bluetooth
 Move the Bluetooth slider to On
 A list of Bluetooth devices will appear
 Tap your IMGadgets WaveBuds in the list to connect

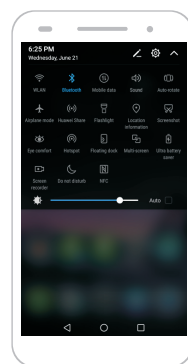

android
 Android
 Go to Setting > Wireless & Networks > Bluetooth settings
 Check the box next to Bluetooth to turn it on
 A list of Bluetooth devices will appear
 Tap your IMGadgets WaveBuds in the list to connect

3 / Full operation guidelines

1. Touch control area
2. Mic
3. Charging interface
4. Charging case battery indicator

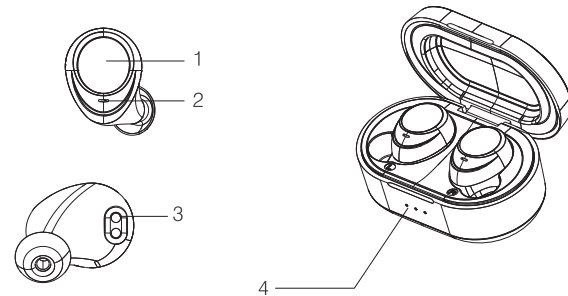

4 / Start Listening

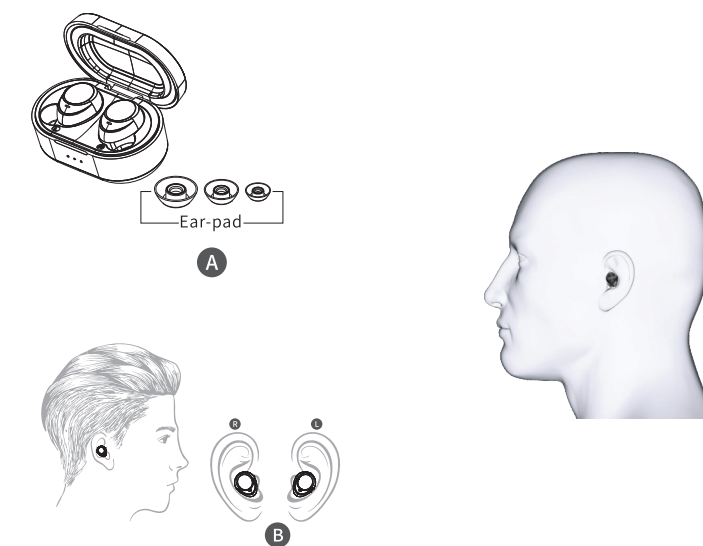

5 / Tap Control Instructions

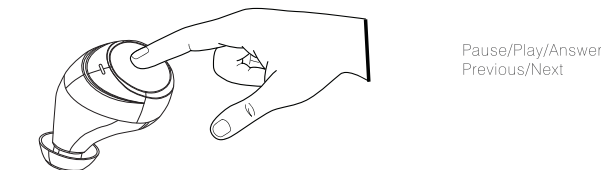

Power Off	Earbuds Off	Take out from charging case or long tap for 3 sec manually
Pairing	Earbuds Off	Long tap for 5 sec manually
Activator On	Stand By Mode	Long tap L earbud for 2 sec to activate Siri/Google Assist.
Activator Off	Stand By Mode	Long tap L earbud for 2 sec to turn off Siri/Google Assist.
Answer Call	Incoming Call	Single Tap L or R earbud
End Call	On Call	Single Tap L or R earbud
Reject Call	Incoming Call	Long tap L or R earbud for 2 sec
Hold Call	On Call	Long tap L or R earbud for 2 sec
Play Music	Connected & Music On	Single Tap L or R earbud
Pause Music	Music Playing	Single Tap L or R earbud
Pre-Track	Music Playing	Double tap L earbud
Next Track	Music Playing	Double Tap R earbud
Power Off	Earbuds On	Put earbuds into charging case or long tap for 8 sec manually
Auto Off	Earbuds On	Disconnected over 5 mins

6 / Charging

Charging by the charging case.

A. Charging of Headset

The indicator light of the charging case is red when being charged, and will turn off automatically after being fully charged.

B. Charging of Charging Base

Use the USB charging cable to charge, and will automatically turn off after being fully charged

Put the earbuds (L/R) to the corresponding position in the charging case & close tightly

Charging Micro USB to the charging case

Use the USB Cable to connect with computer

Use the USB Cable to connect with mobile phone charger

Warning:
 You must select a qualified charger from a regular manufacturer. (Charging voltage: 5V, 900 mAh for charging case, 50 mAh for earbuds). A fully charged headset will lose its power automatically if left unused. It is recommended to charge the headset every 3 months. Do not leave the headset in very hot or cold conditions (best between -10°C and 40 °C) which may affect the headset's operations although it is fully charged. Please take out the earbuds from the charging case and store it separately if not in use for a long time. Do not dispose of in water or fire.