

To watch our setup video and for all guides for MojoDesk and accessories please visit mojodesk.com/help

Kit Contents

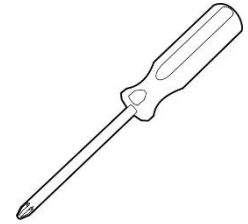

You will need:
Phillips Screwdriver

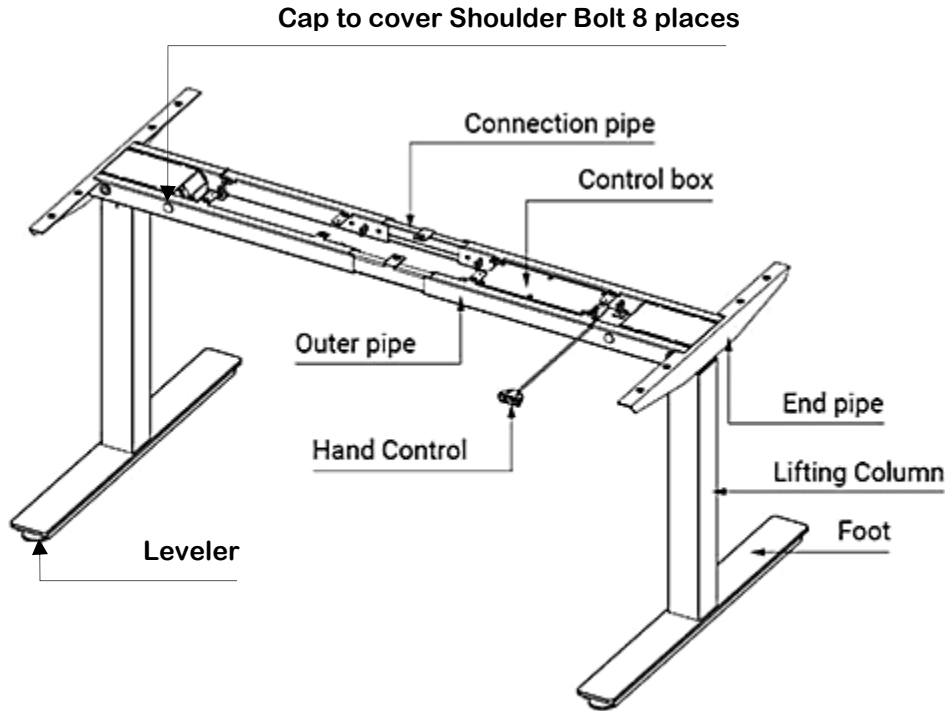
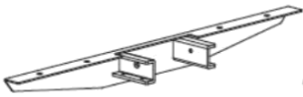

End Pipe - Qty 2

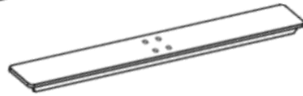

Foot – Qty 2

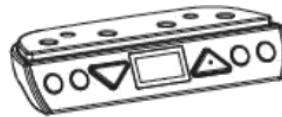

Hand Control – Qty 1



Safety Sensor – Qty 1
Black Screws – Qty 2
(in baggie)



Shoulder Bolt – Qty 4
Color: Silver

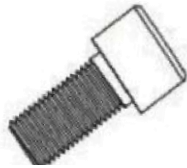

Foot Bolt – Qty 8
Color: Silver



Table Top Screw – Qty 16
Color: Silver



Hand Control Screw – Qty 2
Color: Black



5mm Allen Key – Qty 1

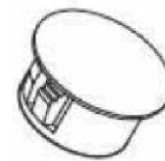

Cap – Qty 8

MojoDesk Assembly Instructions

Step 1 – Open the carton on a flat floor or work area. Do not discard box. The box is designed to unfold to a work surface to avoid scratching during assembly.

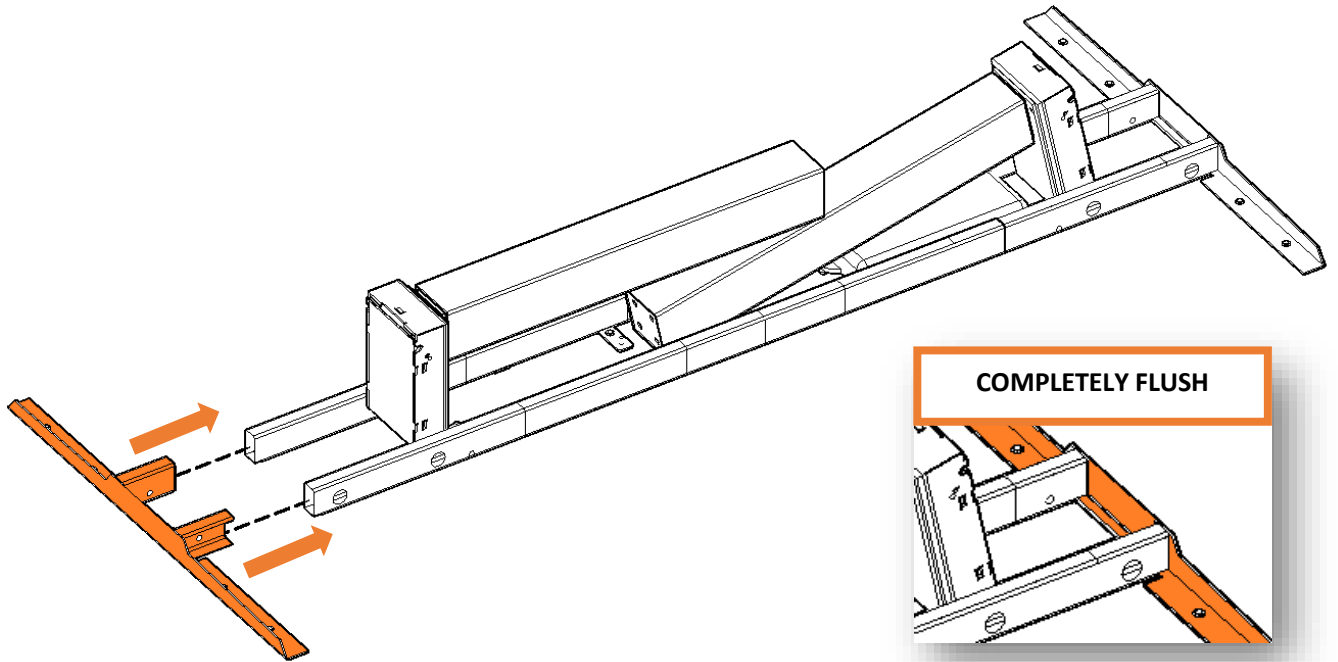

Step 2 – Insert the end pipes into ends of the desk frame. The end pipe needs to be inserted such that that it is completely flush with the outer pipes of the desk frame.

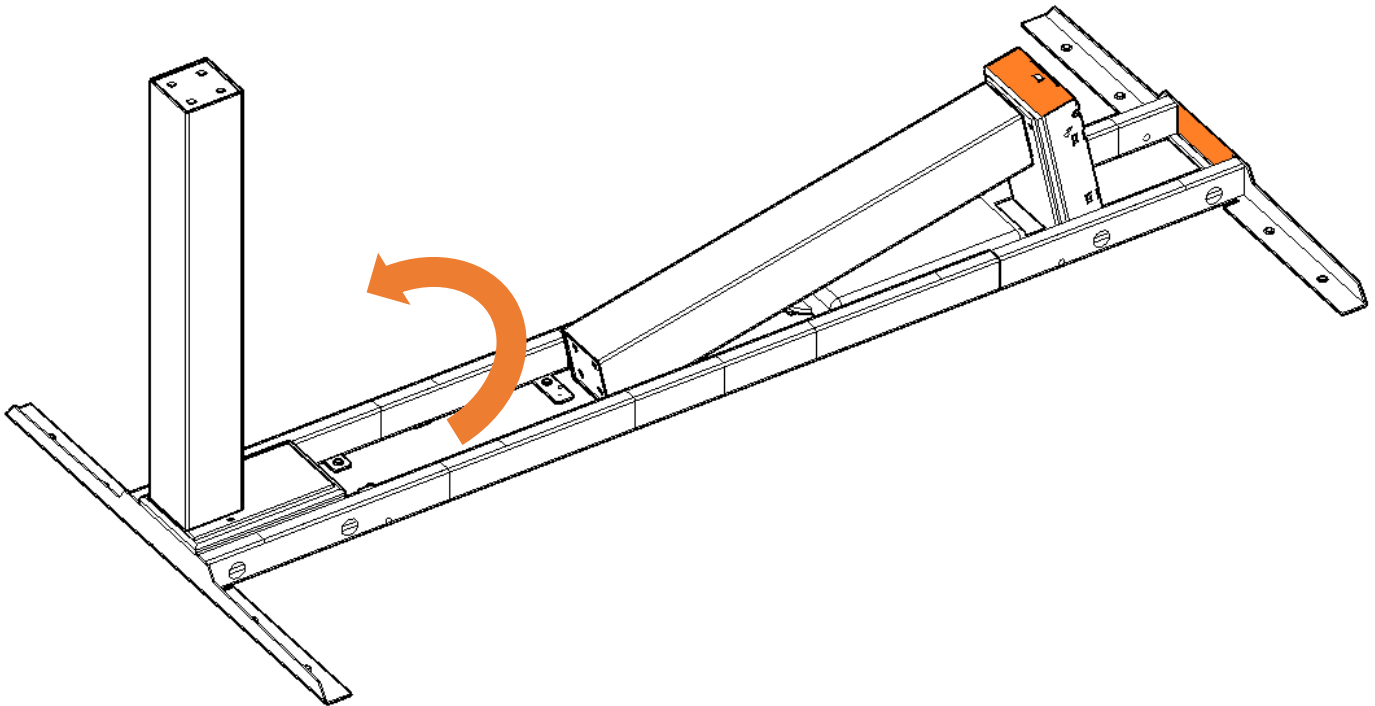

Step 3 - Pivot legs into a vertically upright position. Verify the end pipes are fully inserted into the frame, and that the rear of the legs are flush with the end pipes.



MojoDesk Assembly Instructions

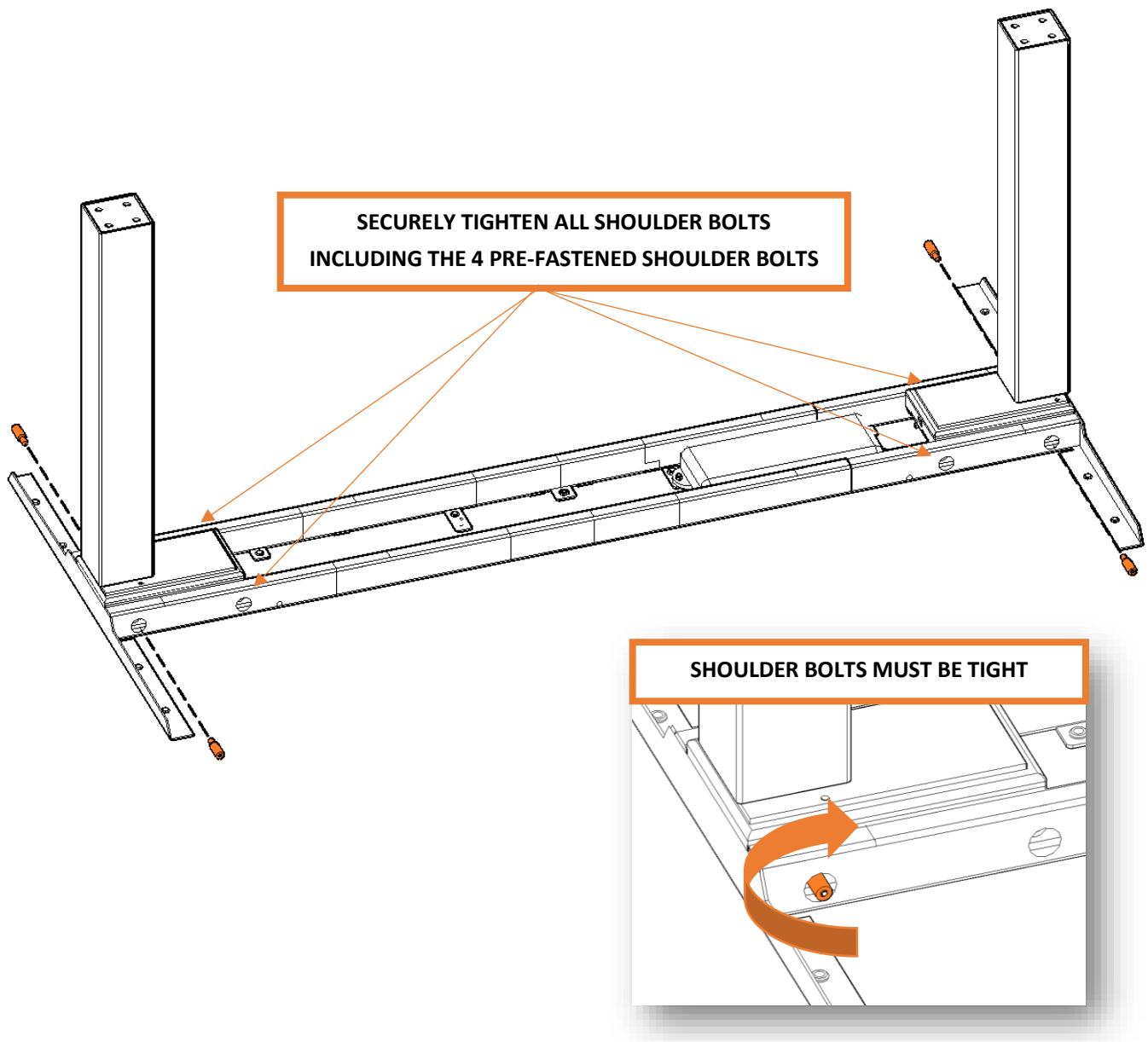

Step 4 – Install shoulder bolts (4 pcs) to secure each leg and end pipe into the desk frame with the supplied Allen Key. Torque the bolts tightly so the legs don't move in the frame. After securely fastening the 4 shoulder bolts it is **IMPORTANT** the other 4 pre-fastened shoulder bolts get tightened as well. For ultimate stability and strength **ENSURE ALL 8 SHOULDER BOLTS ARE SUPER TIGHT.**



MojoDesk Assembly Instructions

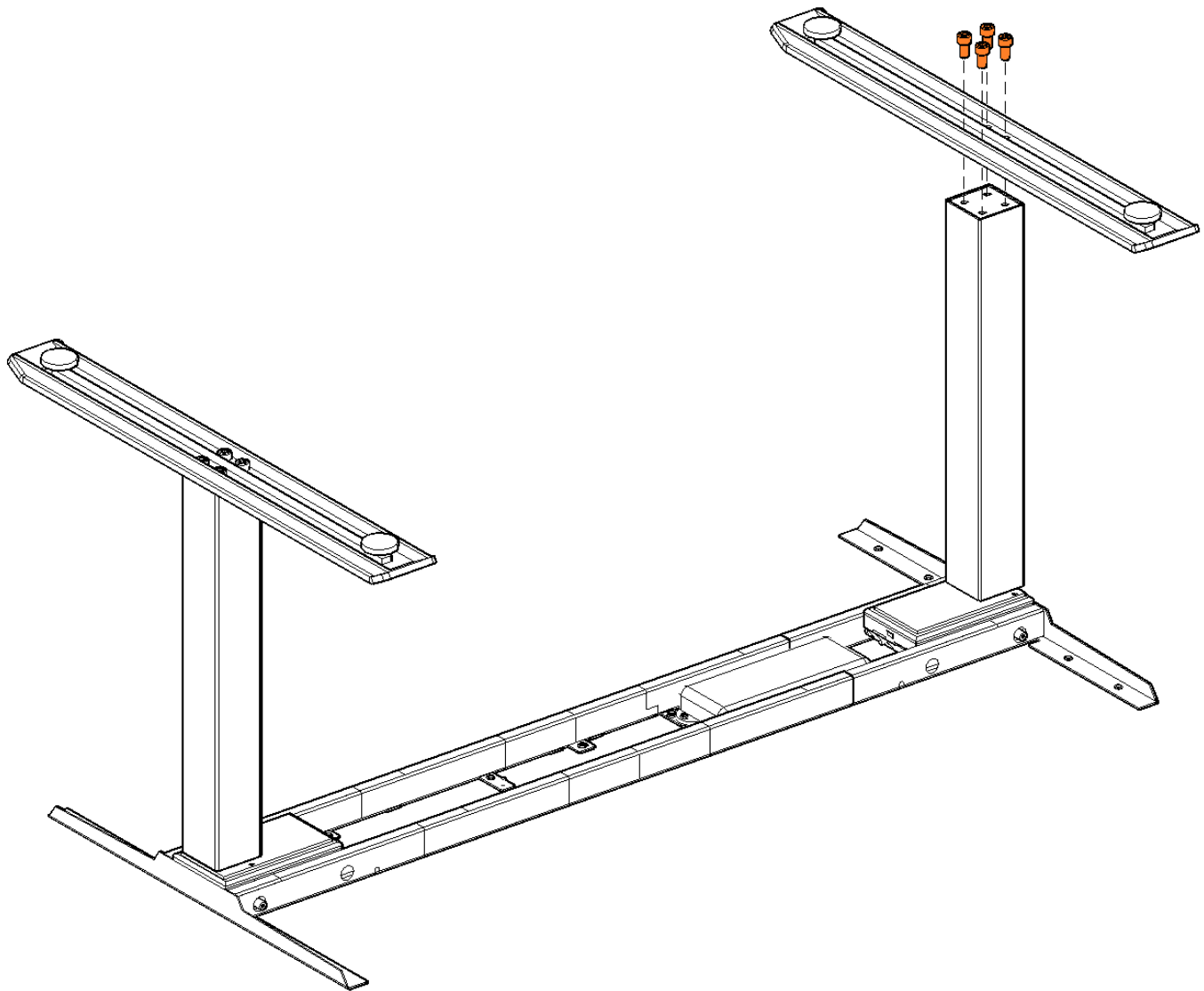

Step 5 – Attach feet to the lifting columns using foot bolts (4 bolts per foot) and the supplied Allen key. Torque the bolts tightly so the feet don't move on the legs.





MojoDesk Assembly Instructions

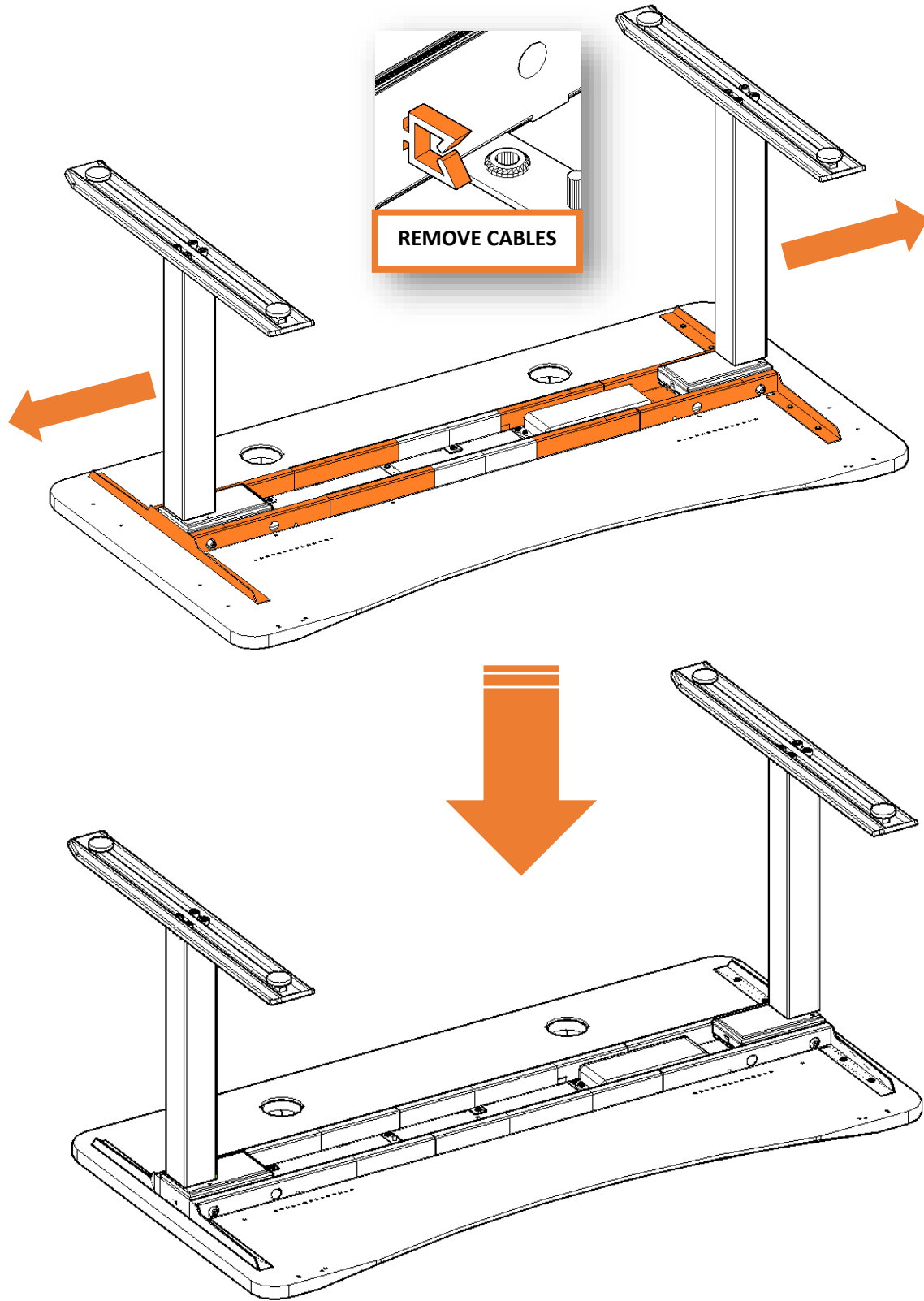

Step 6 – Move the assembled desk frame to the tabletop (Team Lift Recommended). Remove the cables from the cable management clips. Adjust the table frame to achieve appropriate span between lifting columns. Align mounting holes in end pipes and desk frame with the pre-drilled holes in the table top.



MojoDesk Assembly Instructions

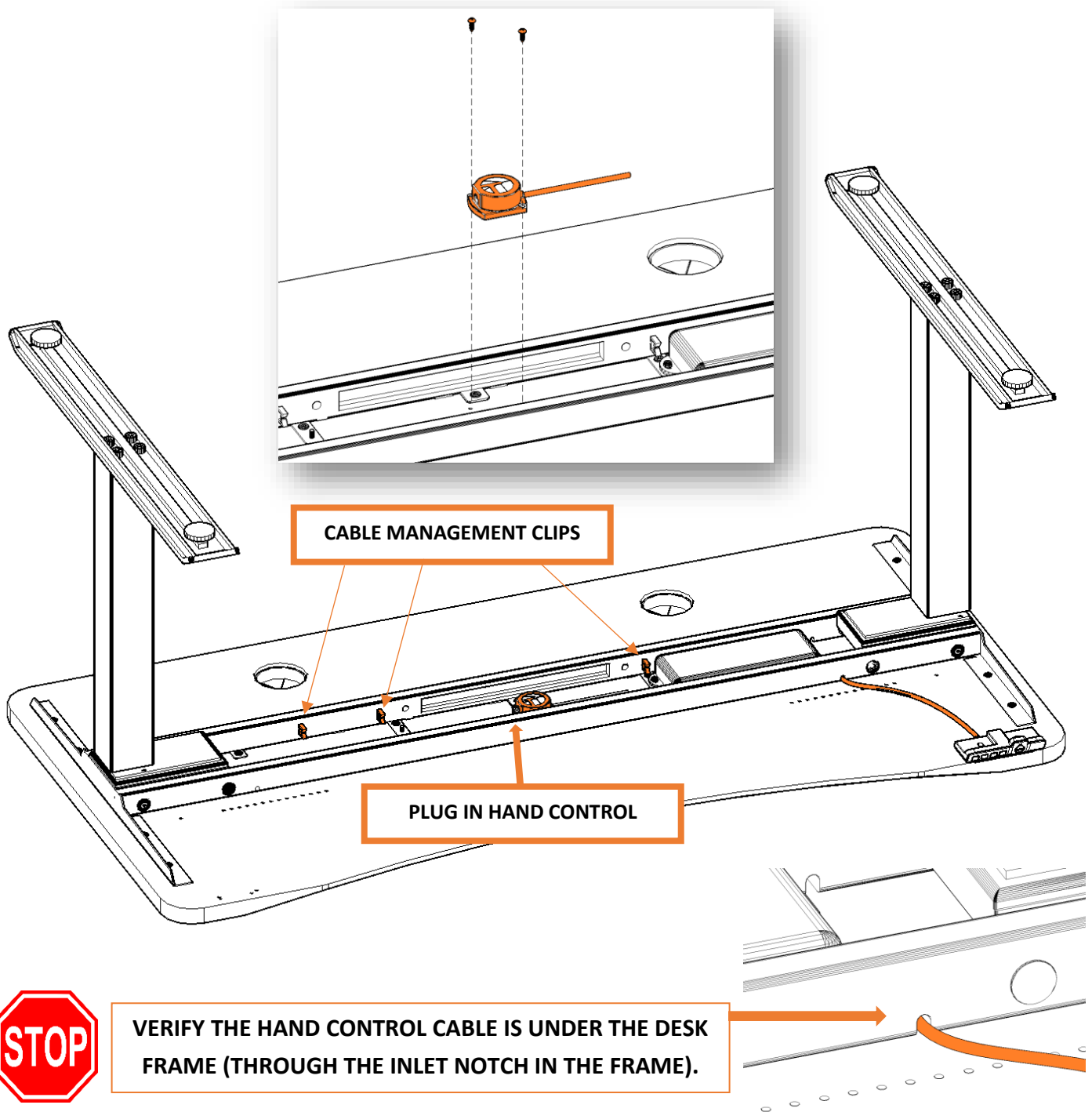

Step 7 – Mount the safety sensor as shown using the two pre-drilled holes in the center of the table top with the **TWO BLACK SCREWS INCLUDED IN BAGGIE**. Plug the safety sensor into the control box and plug the hand control into the safety sensor. Run the wire through the cable management clips. Then, run the hand control wire through the inlet notch in the frame.

MojoDesk Assembly Instructions

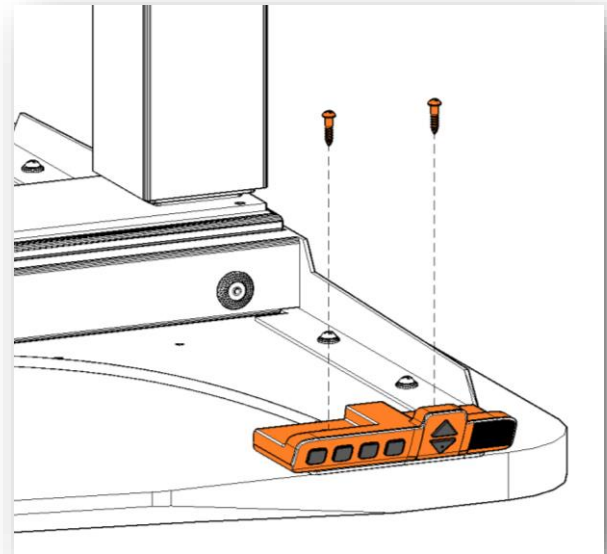
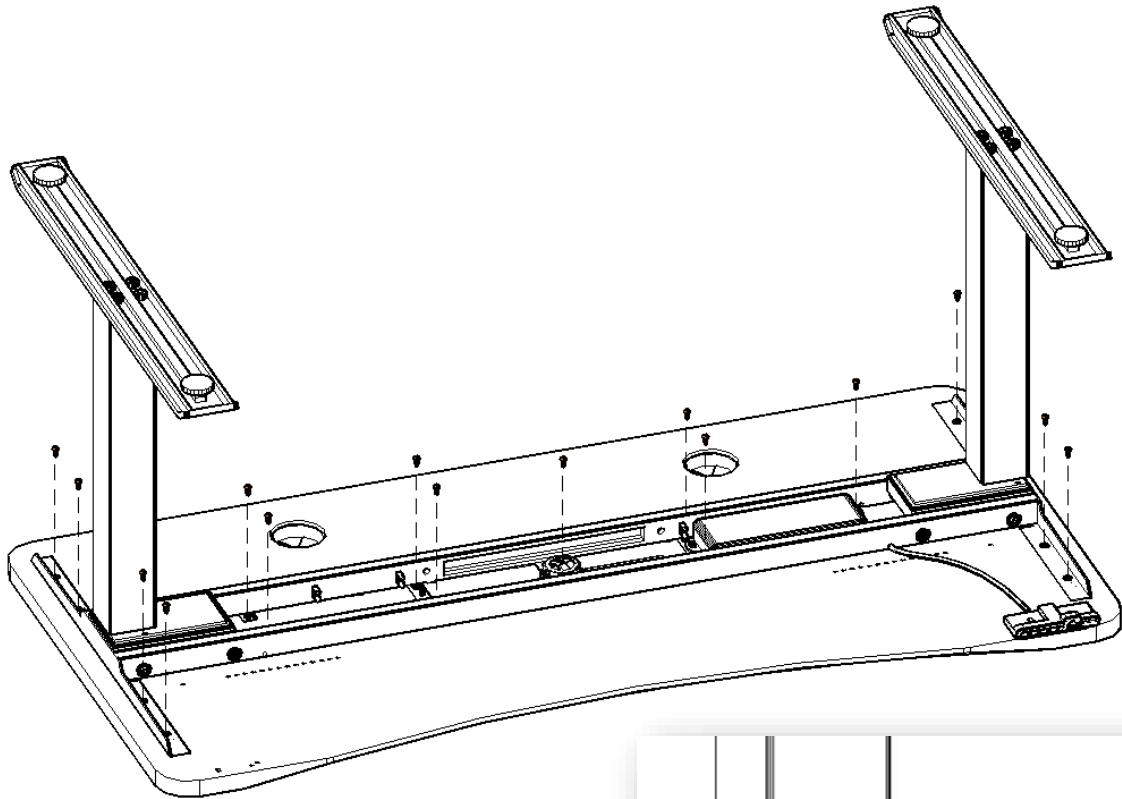

Step 8 – Mount the assembled desk frame to the tabletop with **SILVER TABLE TOP SCREWS**. Then, install the hand control to the table top as shown in circled detail with **TWO BLACK HAND CONTROL SCREWS**.

- Note :**
- The frame placement on the work surface is angled on certain size tables for ultimate stability and strength
 - DO NOT overtighten black hand control screws to avoid the possibility of piercing through the desk top



MojoDesk Assembly Instructions

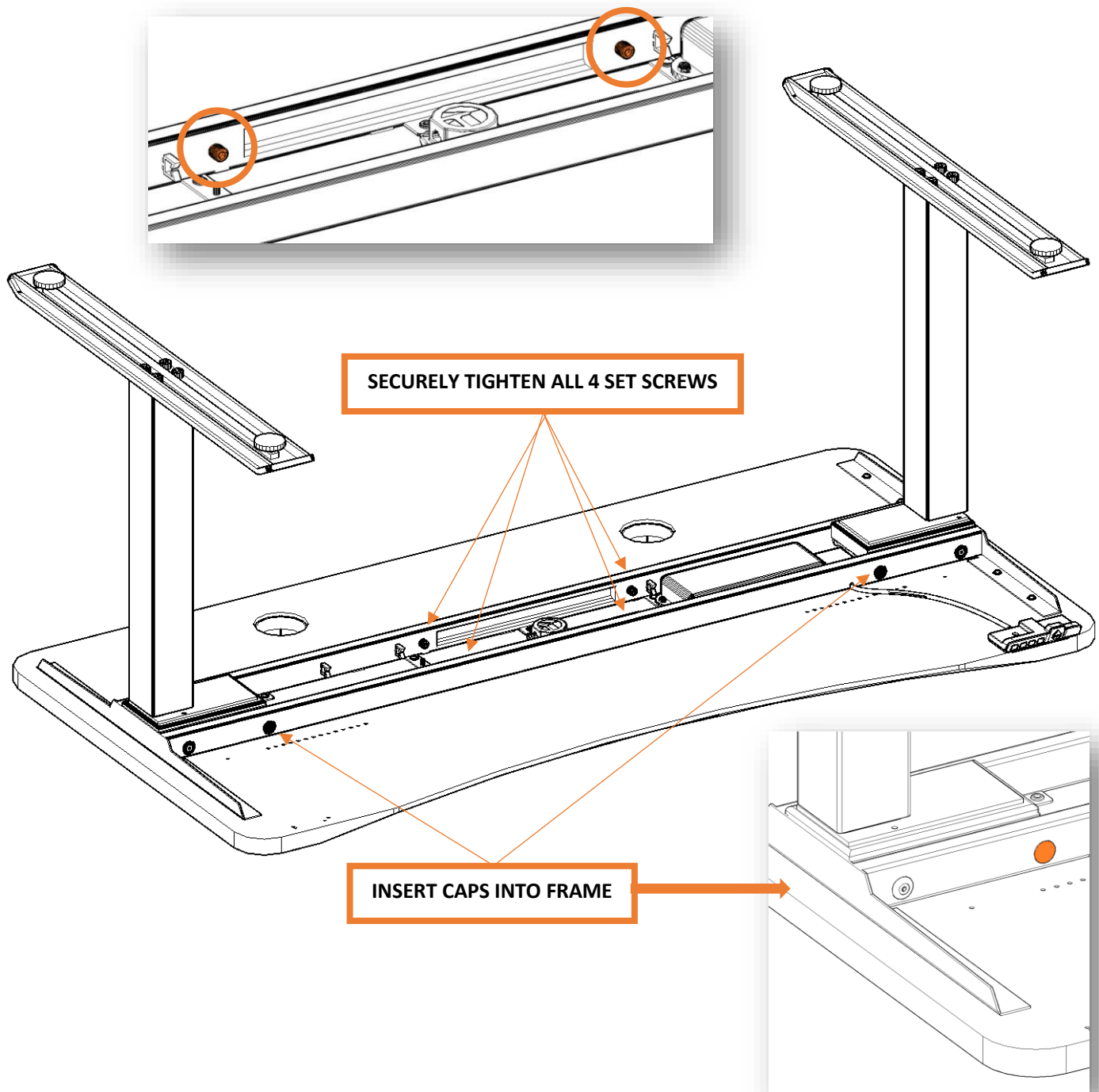

Step 9 – After the desk frame is secured to the tabletop, use the supplied Allen key to tighten the set screws.

Step 10 – Install caps into holes where the lifting columns mount to the desk frame



MojoDesk Assembly Instructions

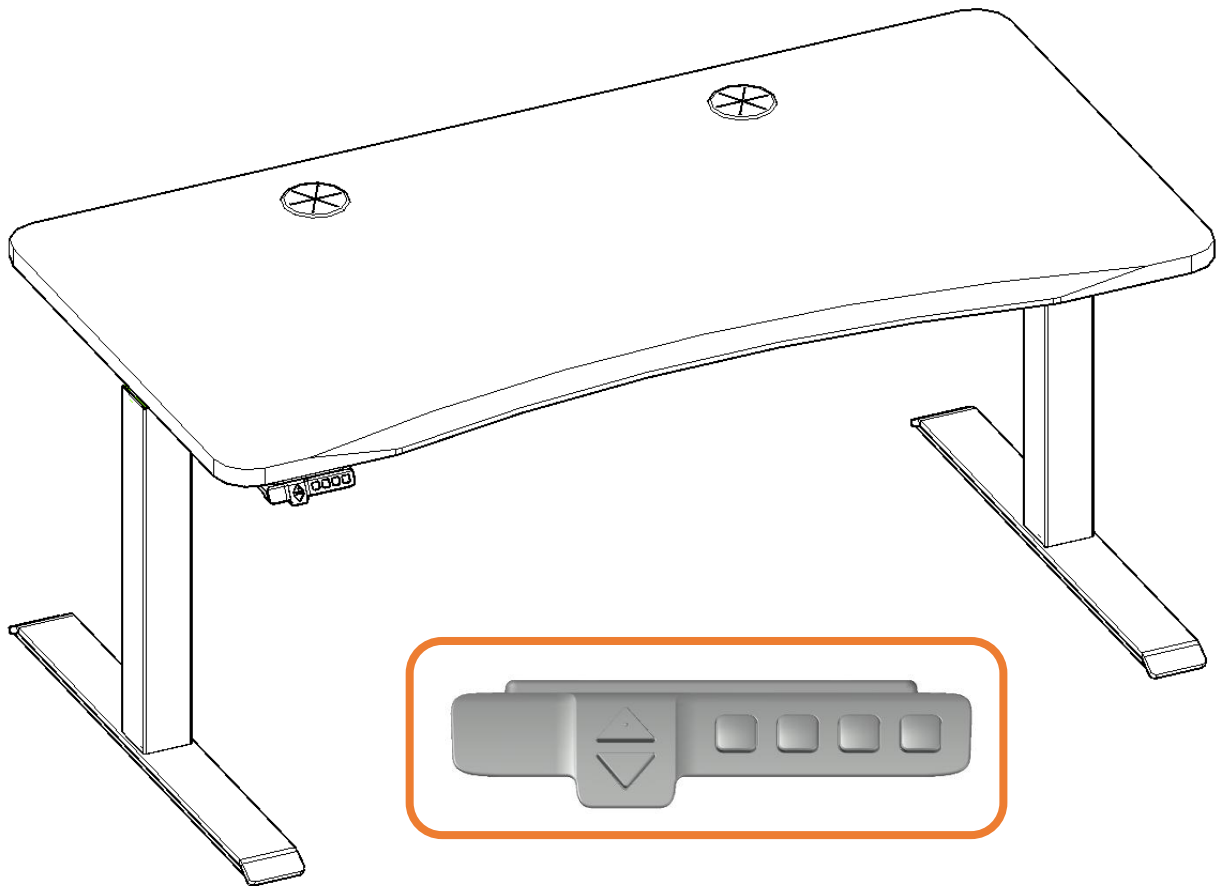

- Step 11** – a. Flip over the desk (Team Lift Recommended). Insert power cable into the control box, then plug in the power cord to a standard wall outlet. Reset the control box by simultaneously pressing and holding the up and down arrows for 5 seconds until you hear a beep AND you see 000 in the display. (Note: If you have already raised the desk higher than the bottom position of 62 then the desk will need to move downwards to position 62, beep and display 000 to confirm a reset).
- b. For perfect balance, adjust the levelers (4) under the feet by turning them.
- c. To set the memory for a specific height, raise or lower the desk to the desired height, then press and hold one of the memory position button and either the up or down arrow simultaneously until P1, P2, P3, or P4 appears on the control display. When moving the desk to a set position hold the memory position button and release. The table will automatically raise and lower to the preset position.

To watch our setup video and for all guides for MojoDesk
and accessories please visit mojodesk.com/help

