

**ANSI/HFES 100-2007**

***Human Factors Engineering of Computer Workstations***



**Published by the Human Factors and Ergonomics Society  
P.O. Box 1369  
Santa Monica, CA 90406-1369 USA  
310/394-1811, Fax 310/394-2410  
info@hfes.org, <http://hfes.org>**

© 2007 by the Human Factors and Ergonomics Society. All rights reserved. No portion of this document may be reproduced, stored, or transmitted by any means without prior written permission of the Human Factors and Ergonomics Society. Address orders and permission requests to the Communications Department at the address above.

# Table of Contents

<b>FOREWORD</b> .....	<b>1</b>
<b>1 PURPOSE</b> .....	<b>3</b>
<b>2 GENERAL SCOPE</b> .....	<b>4</b>
2.1 Guiding Principles .....	6
2.2 Limitations.....	7
<b>3 CONFORMANCE POLICY</b> .....	<b>8</b>
3.1 Conformance Exclusions .....	8
<b>4 CITED STANDARDS</b> .....	<b>9</b>
<b>5 INSTALLED SYSTEMS</b> .....	<b>10</b>
5.1 Purpose and Scope .....	11
5.2 Design Specifications .....	11
5.2.1 General Specifications .....	11
5.2.1.1 User Postures .....	12
5.2.1.2 Adjustment Controls in the Workstation.....	14
5.2.1.3 Adjustable Surfaces .....	14
5.2.1.4 Pinch Points .....	15
5.2.1.5 Device Cabling .....	15
5.2.2 Beneath the Work Surface .....	15
5.2.2.1 Leg and Foot Clearance .....	15
5.2.2.2 Footrests.....	16
5.2.3 In Front of the Work Surface .....	16
5.2.3.1 Chairs.....	16
5.2.3.2 Chair Casters.....	16
5.2.3.3 Chair Seat Pan and Backrest Adjustments .....	17
5.2.3.3.1 Armrests .....	18
5.2.3.4 Input Device Location .....	18
5.2.3.5 Arm and Wrist/Palm Supports .....	20
5.2.4 On Top of the Work Surface .....	21
5.2.4.1 Horizontal Work Envelope .....	21
5.2.4.2 Monitor Support Surface .....	22
5.2.4.3 Monitor Viewing Angle.....	23
5.2.4.4 Document Holders .....	24
5.2.5 Surrounding the Work Surface.....	24
5.2.5.1 Illuminance .....	24
5.2.5.2 Luminance Balance.....	25
5.2.5.3 Acoustical Noise.....	25
5.2.5.4 Mechanical Vibrations.....	25
5.2.5.5 Contact Surface Temperature .....	26
5.2.5.6 Ambient Thermal Conditions .....	26
5.2.5.7 Product Emissions .....	27
5.2.5.8 Electromagnetic Compatibility .....	27
5.2.5.9 Static Electricity.....	27

5.3	Conformance .....	28
5.3.1	User Postures.....	28
5.3.2	Control Clearance for Users' Feet and Legs .....	29
5.3.3	Pinch Points .....	29
5.3.4	Leg and Foot Clearance.....	29
5.3.5	Footrests.....	29
5.3.6	Chairs .....	29
5.3.7	Chair Seat Pan and Backrest Adjustments .....	29
5.3.8	Armrests.....	30
5.3.9	Input Device Location .....	30
5.3.10	Monitor Support Surface .....	30
5.3.11	Illuminance.....	31
5.4	References .....	31

## **6 INPUT DEVICES ..... 34**

6.1	Purpose and Scope.....	34
6.2	Design Specifications .....	34
6.2.1	General Specifications .....	34
6.2.1.1	Control Dynamics.....	34
6.2.1.2	Device Stability.....	35
6.2.1.3	Intentional Movements .....	35
6.2.1.4	Grip Surface.....	35
6.2.1.5	Handedness .....	35
6.2.1.6	Surface Reflectance .....	36
6.2.1.7	Edges, Corners, and Surfaces.....	36
6.2.1.8	Button Placement.....	36
6.2.1.9	Button Force and Displacement.....	36
6.2.1.10	Button Feedback .....	37
6.2.1.11	Button Lock .....	37
6.2.1.12	Labels.....	37
6.2.2	Keyboards .....	37
6.2.2.1	Keyboard Layout .....	38
6.2.2.1.1	Alphabetic Keys.....	38
6.2.2.1.2	Numeric Keypads .....	38
6.2.2.2	Cursor Control .....	39
6.2.2.3	Keyboard Height, Slope, and Wrist/Palm Support.....	40
6.2.2.4	Profile .....	42
6.2.2.5	Dual-State Keys .....	42
6.2.2.6	Key Nomenclature .....	42
6.2.2.7	Key Spacing.....	43
6.2.2.8	Key Size and Shape .....	43
6.2.2.9	Key Force.....	43
6.2.2.10	Key Displacement.....	44
6.2.2.11	Key Rollover/Simultaneous Key Depression.....	45
6.2.2.12	Keying Feedback .....	45
6.2.2.13	Key Repeat Rate .....	46
6.2.2.14	Home Row Locator.....	46
6.2.2.15	Keyboard Wrist Rest.....	46
6.2.3	Mouse Devices .....	46
6.2.3.1	Shape and Size.....	47
6.2.3.2	Motion Sensor.....	47
6.2.4	Puck Devices.....	47
6.2.4.1	Shape and Size.....	48

6.2.5	Trackballs.....	48
6.2.5.1	Diameter .....	48
6.2.5.2	Resistance .....	49
6.2.6	Joysticks.....	49
6.2.6.1	Handle Size.....	50
6.2.6.2	Force .....	50
6.2.6.3	Displacement .....	50
6.2.7	Styli and Light Pens .....	50
6.2.7.1	Surface.....	51
6.2.7.2	Button Shape.....	51
6.2.7.3	Diameter .....	51
6.2.7.4	Length.....	51
6.2.8	Tablets and Overlays.....	51
6.2.8.1	Surface.....	51
6.2.8.2	Attachment and Detachment.....	52
6.2.9	Touch-Sensitive Panels .....	52
6.2.9.1	Minimum Touch Area .....	52
6.2.9.2	Dead Space .....	52
6.2.9.3	Target Tracking .....	53
6.3	Metrics .....	53
6.3.1	Device Stability.....	53
6.3.2	Numeric Keypad Layout.....	53
6.3.3	Cursor Control.....	53
6.3.4	Keyboard Height and Slope .....	53
6.3.5	Key Spacing .....	53
6.3.6	Key Force.....	54
6.3.7	Key Displacement .....	54
6.3.8	Keying Feedback.....	54
6.3.9	Shape and Size .....	54
6.4	References .....	54

## **7 VISUAL DISPLAYS ..... 56**

7.1	Purpose and Scope.....	56
7.2	General Specifications .....	56
7.2.1	Default Configuration .....	56
7.2.2	Viewing Characteristics .....	57
7.2.2.1	Design Viewing Distance .....	57
7.2.2.2	Gaze Angle .....	58
7.2.2.3	Design Angular Viewing Envelope .....	58
7.2.3	Spatial Characteristics.....	59
7.2.3.1	Moiré .....	59
7.2.3.2	Pixel Grid Modulation, Fill Factor, and Pixel Pitch.....	60
7.2.3.3	Pixel and Subpixel Faults .....	61
7.2.3.4	Geometric Distortion .....	61
7.2.3.5	Graphic Orthogonality Error.....	62
7.2.4	Temporal Quality .....	62
7.2.4.1	Response Time.....	62
7.2.4.2	Temporal Coding.....	62
7.2.4.3	Flicker.....	62
7.2.4.4	Jitter .....	63
7.2.5	Luminance and Color Quality.....	64
7.2.5.1	Luminance Range .....	64
7.2.5.2	Luminance Nonuniformity.....	64
7.2.5.3	Luminance Contrast and Reflections .....	64

7.2.5.4	Luminance Coding.....	65
7.2.5.5	Image Polarity.....	65
7.2.5.6	Default Color Set.....	66
7.2.5.7	Color Differences.....	66
7.2.5.8	Color Uniformity.....	66
7.2.5.9	Number of Colors.....	66
7.2.5.10	Background/Foreground Interactions.....	67
7.2.6	Information Format.....	67
7.2.6.1	Character Height.....	67
7.2.6.2	Sizes of Colored Characters.....	68
7.2.6.3	Character Width-to-Height Ratio.....	68
7.2.6.4	Stroke Width.....	68
7.2.6.5	Character Format.....	68
7.2.6.6	Spacing Between Characters.....	69
7.2.6.7	Spacing Between Lines.....	69
7.2.6.8	Spacing Between Words.....	69
7.3	References.....	70

## **8 FURNITURE..... 73**

8.1	Purpose and Scope.....	73
8.2	General Specifications.....	73
8.2.1	User Postures.....	74
8.3	Design Specifications.....	75
8.3.1	General Specifications.....	75
8.3.1.1	Stability.....	75
8.3.1.2	Pinch Points.....	76
8.3.1.3	Workstation Adjustments.....	76
8.3.1.4	Finish of Furniture and Accessories.....	76
8.3.1.5	Surface Gloss.....	76
8.3.2	Surfaces.....	77
8.3.2.1	Operator Clearances.....	77
8.3.2.1.1	Method 1—Reclined Seated and Upright Seated Postures.....	77
8.3.2.1.2	Method 2—Upright, Reclined, and Declined Seated Postures.....	77
8.3.2.2	Work Surfaces.....	80
8.3.2.3	Monitor Support Surface/Device.....	81
8.3.2.4	Input-Device Support Surface.....	81
8.3.2.4.1	Sit-Only Working Postures.....	82
8.3.2.4.2	Stand-Only Working Postures.....	82
8.3.2.4.3	Sit/Stand Working Postures.....	83
8.3.2.5	Standing Operator Foot Clearances.....	84
8.3.3	Seating.....	85
8.3.3.1	Height.....	85
8.3.3.2	Depth and Front Edge of the Seat Pan.....	85
8.3.3.3	Seat Pan Width.....	85
8.3.3.4	Seat Pan Angle.....	85
8.3.3.5	Seat Pan—Backrest Angle.....	86
8.3.3.6	Backrest Height and Width.....	86
8.3.4	User Supports.....	87
8.3.4.1	Armrests.....	87
8.3.4.2	Wrist/Palm, Forearm Supports.....	87
8.3.4.3	Footrests.....	88
8.4	Conformance.....	88
8.4.1	Supplier Conformance.....	88
8.4.1.1	Surfaces.....	88
8.4.1.2	Seating.....	89
Appendix A	.....	91

A.1 Anthropometric Derivations .....	91
A.1.1 Anthropometric Data .....	91
A.1.2 Univariate Data .....	91
A.1.3 Adding Percentiles .....	91
A.1.4 Unidimensional Data .....	91
A.1.5 Multidimensional Data .....	92
A.1.6 Iterative Solution to Clearance Space .....	92
A.2 Clearance Under the Work Surface .....	93
A.2.1 Deriving the Models .....	93
A.2.1.1 Minimum Width .....	93
A.2.1.2 Minimum Knee Depth .....	93
A.2.1.3 Minimum Foot Depth .....	93
A.2.1.4 Maximum Thigh Height .....	94
A.2.1.5 Maximum and Minimum Knee Height .....	94
A.2.1.6 Upper Limits .....	94
A.2.1.6.1 Method 1—Upright and Reclined Seated Postures .....	94
A.2.1.6.2 Method 2—Upright and Declined Seated Postures .....	95
A.2.1.7 Lower Limit .....	95
A.3 Seat Height .....	95
A.3.1 Deriving the Models .....	95
A.3.1.1 Maximum Seat Height .....	96
A.3.1.2 Minimum Seat Height .....	96
A.3.2 Defining Accommodation Ranges .....	97
A.4 Standing and Sit-Stand Work Surfaces; Height and Angle Adjustments .....	97
A.4.1 Deriving the Models .....	97
A.4.1.1 Standing Support Surface Height .....	97
A.4.2 Defining Accommodation Ranges .....	97
8.5 References .....	98

## LIST OF FIGURES

5-1. Reference Postures for Computer Workstation Users .....	11
5-2. Elbow Reference Postures .....	12
5-3. Shoulder Abduction Reference Postures .....	13
5-4. Shoulder Flexion Reference Postures .....	13
5-5. Wrist Flexion and Extension Reference Postures .....	13
5-6. Torso-to-Thigh Reference Postures .....	13
5-7a. Side View of Recommended Space for Placement of Input Devices .....	19
5-7b. Top View of Recommended Space for Placement of Input Devices .....	20
5-8. Nomenclature for Wrist/Palm Support Dimensions .....	21
5-9. Recommended Space for Input Devices and Primary, Secondary, and Tertiary Horizontal Work Zones .....	22
5-10. Diagram of Manual Goniometer .....	28
6-1. Row References for Conventional Keyboards .....	38
6-2. Numeric Keypad Layouts .....	39
6-3. Cursor Key Layouts .....	39
6-4. Illustration of Keyboard Slope .....	40
6-5. Keyboard Height Measured from Table Surface to Middle of Home Row of Keyboard .....	41
6-6. Keyboard Slant and Tilt .....	41
6-7. Illustration of Key Spacing .....	43
6-8. Example of Force Displacement Curves .....	44
6-9. Illustration of a Mouse .....	47
6-10. Illustration of a Puck .....	48
6-11. Illustration of a Trackball .....	48

6-12.	Exposed Surface and Diameter of Trackball .....	49
6-13.	Finger-Operated and Hand-Operated Joysticks .....	49
6-14.	Illustrations of Light Pen and Stylus.....	50
6-15.	Touch Panel Dead Space .....	53
7-1.	Design Angular Viewing Envelope .....	59
7-2.	Spatial Limits on the Display Surface Imposed by the Design Angular Viewing Envelope at the Design Viewing Distance .....	60
7-3.	Maximum Contrast of Moiré Patterns .....	61
7-4.	Height and Width of Characters .....	67
7-5.	Spacing Between Characters, Lines, and Words .....	69
8-1.	Reference Postures for Computer Workstation Users.....	74
8-2.	Placement of Clearance Space Boxes .....	78
8-3a.	Clearance Spaces for Method 1 .....	79
8-3b.	Clearance Spaces for Method 2 .....	79
8-4.	Method of Combining Height and Tilt for Input-Device Support Surfaces.....	83
A-1.	Clearance Dimensions .....	93
A-2.	Seat Height Dimensions .....	96

## LIST OF TABLES

5-1.	Surface Temperature and Contact Time .....	26
7-1.	Default Display Configuration.....	57
8-1.	Combinations of Height and Tilt Within the Acceptable Ranges for Standing Work .....	83
8-2.	Assessment of Chair Conformance Using BIFMA Chair Measuring Device .....	90
A-1.	Combinations of Elbow Angle and Surface Height.....	98

# FOREWORD

This standard contains hardware design specifications that are based on accepted human factors engineering research and experience for computer workstations, their associated furniture, and the end user's workplace environment. This standard was developed by the Human Factors and Ergonomics Society (HFES), using the rules and procedures of the American National Standards Institute (ANSI).

This edition is the first revision of ANSI/HFES100-1988, *American National Standard for Human Factors Engineering of Visual Display Terminal Workstations*. This edition of the standard incorporates several extensions based on technology advancements and increased human factors knowledge to the technical areas discussed in ANSI/HFES100-1988.

The members of the ANSI/HFES 100 Committee who drafted this edition are listed below:

Thomas J. Albin <i>Chair</i> Auburn Engineers	David Carson Xybix	Stephen Guttman S. H. Guttman Consulting, LLC
Marvin Dainoff, Ph.D. <i>Vice Chair</i> Miami University	David Cochran University of Nebraska, Lincoln	Thomas Hayosh Unisys Corporation
Sumner Adams Kimball International	H. Harvey Cohen Error Analysis, Inc.	Alan Hedge, Ph.D. <i>Chair, Environment Subcommittee</i> Cornell University
Dennis Ankrum Nova Office Furniture	Ed Coleman Lexmark International	Robert Hennessy <i>Chair, Visual Displays Subcommittee</i> Monterey Technologies
Ruthjean Banks California State Compensation Insurance Fund	John Cone IBM	Mark Hoffman NCR
Dennis Bechis, Ph.D. National Information Display Laboratory	Jack Dennerlein, Ph.D. Harvard University	Carlo Infante, Ph.D. CBI Technology Consultants
Teresa Bellinger Haworth	Dan Donohoo, Ph.D. Battelle	Philip Jacobs Jacobs Consulting
Carolyn Bensel U.S. Army Research, Development and Engineering Command	Bill Dowell Herman Miller	Tamara James Duke University Medical Center
Ted Braun Liberty Mutual Insurance	Richard Driscoll BIFMA	Peter Johnson, Ph.D. University of Washington
Jim Briggs, Ph.D. (deceased) Boeing Commercial Airplane	George English KeyTronic	Al Jorgenson Quantum Data
Dennis Burnside United States Air Force Research Laboratory	James Gerner Gerner & Associates	Edward F. Kelley NIST
Dick Cappels Apple Computer, Inc.	Claire Gordon, Ph.D. United States Army Natick Research and Development Center	Peter Kennedy Apple Computer, Inc.
	Chris Grant, Ph.D. University of Michigan	Walter Kleeman, Jr. (deceased) The Worldport Corporation
	James Greeson Ergonomic Solutions	



Doug Kokot Koala Consulting	Ken Miller Photo Research	James Sheedy, Ph.D. University of California
Karl H. E. Kroemer, Ph.D. <i>Chair, Furniture Subcommittee</i> Virginia Tech	Michael Miller, Ph.D. Eastman Kodak Center	Louis Silverstein, Ph.D. VCD Sciences, Inc.
Nancy Larson 3M	Abbas Moallem San Jose State University	Tom Sluchak IBM
David LeGrande Communication Workers of America	Michael O'Neill, Ph.D. Herman Miller	Wanda Smith <i>Chair, Input Devices Subcommittee</i> Global Ergonomic Technologies
Win Lochridge Metamorphosis	Karen Piegorsch Synergo	Carolyn M. Sommerich, Ph.D. North Carolina State University
LTC Mary Lopez United States Army	Richard Pekelney RS Pekelney Engineering	Carla Springer, Ph.D. C. J. Springer & Associates
Rani Lueder Humanics	Alan Poston Federal Aviation Administration	Laura Stock Labor and Occupational Health Program
Walter Makous, Ph.D. <i>Chair, Visual Displays Canvass Subcommittee</i> University of Rochester	Douglas Prickett Kimball International	David Thompson, Ph.D. Portola Associates
Richard Marklin, Ph.D. Marquette University	Cynthia Purvis Hewlett Packard Corporation	Kathy Uyeda, Ph.D. TDS Health Care
Daniel McCrobie, Ph.D. Honeywell, Inc.	James Reger, Ph.D. Compaq Computers	Harold Welch Apple Computer, Inc.
Dennis McIntosh Center for Office Technology	Kathleen Robinette, Ph.D. United States Air Force Research Laboratory	Don Williams, Ph.D. Abilene Christian University
Hugh McLoone Microsoft	Marie Robinson Pacific Bell	Helmut Zwahlen, Ph.D. Ohio University
Gerry McVey, Ph.D. (deceased) Boston University	Diana Roose Oberlin College	
Sharon Middendorf <i>Noncommittee member- Contributor</i> 3M	Fred Schott Aetna Life and Casualty	
	Brian Shaw The Aerospace Corporation	

# 1 PURPOSE

This technical standard specifies acceptable applications of human factors engineering principles and practices to the design and configuration of the human-hardware interfaces in computer workstations.

For the purposes of this standard, the term *computer workstation* refers to an operator-machine system consisting of a computing unit and, more important, several associated hardware components that form interfaces with the users of the system. The user interfaces addressed by this standard are input devices, output devices, and furniture. Because the application of human factors engineering principles and practices requires the consideration of specific end-user situational constraints, this standard also considers the configuration of the installed workstation components and the ambient environment immediately surrounding the computer workstation.

This standard applies to computer workstations used regularly in office workplaces by users with normal perceptual and cognitive capabilities for text-, data-, and simple graphics-processing tasks. It is specifically intended for moderate to intensive computer users. The specifications in this standard are not intended to apply to the diverse uses of computers beyond the office workplace application stated above. Although generalizations of some specifications contained in this standard to other applications may be reasonable and justifiable, it must be recognized that such generalizations exceed the scope of this standard. For example, health and safety considerations for users of computer workstations are beyond the intended purposes and stated scope of this standard.

Implementation of this standard and the assessment of conformance with this standard should be performed by trained and knowledgeable human factors engineers and ergonomists. These professionals may have technical responsibilities, in whole or in part, for the design, installation, and inspection of computer workstations and their associated components.

Many specifications contained in this technical standard are presented in a quantitative manner; that is, as numbers representing acceptable design limits. Such specifications are based on accepted empirical data and established human factors engineering principles and practices. Users of these specifications should follow acceptable human factors engineering practice when tailoring the specifications contained in this standard to particular computer workstations and user populations.

NOTE: All normative dimensions in this standard are given in SI units (meter, kilogram, seconds). Dimensions given in US customary units such as inches, pounds, etc. are presented for advisory purposes only and are non-normative.

## 2 GENERAL SCOPE

This standard covers operator-machine interface issues associated with computer workstations used regularly in offices (i.e., intentionally built indoor office workplaces) for text-, data-, and simple graphics-processing tasks. This standard applies to computer workstations for a wide range of users; in general the physical dimensions and force requirements are designed to accommodate at least 90 percent of the North American population.

### **User Diversity<sup>1</sup>**

“In general, the design specifications for the computer workstation components are intended to be equitable; that is, the design accommodates people with diverse abilities.”

However, users may vary in their ability to perceive information that is statically presented or dynamically supplied by the computer workstation, in their ability to understand how to use the product, and in their ability to operate the product. Some users may need to use assistive devices with their computer workstation components. For example, a user with tremor or limited eye-hand coordination might need a special keyboard with increased spacing between the keys.

In some instances, the most practical or feasible means of achieving accommodation of diverse users may be through the use of software intended to be used with the workstation component, such as device drivers, rather than through the physical properties of the device. For example, it may be more practical to adjust key repeat rate via software controls than to build variable activation delays into a key switch circuit.

Because of the very nature of diversity, it is difficult and perhaps even contradictory to attempt to specify a unique set of design criteria that will accommodate all users. For example, a user with very limited strength may require that keys on an input device respond almost instantaneously to a light touch, yet a user with an intentional tremor may require that the keys respond only to a sustained high level of force. At present the research literature does not suffice to answer these accommodation questions, at least at a level sufficient to allow specification.

Similarly, the current state of knowledge does not allow us to determine if there is a single set of design criteria that will result in a computer workstation component suitable for all possible users. However, it is possible to provide designers with some general principles regarding features of computer workstation components that will support accommodation.

### **General Guidelines**

#### ***Perception***

Computer workstation components, either separately or in combination with supporting software, should facilitate diverse users' ability to perceive statically or dynamically displayed information such as

- Key labels
- Key locations
- Feedback from operation of the device
- Status of toggle keys, for example, number lock and capital lock

---

<sup>1</sup> The Human Factors and Ergonomics Society wishes to acknowledge the kind permission of the International Standards Organization to use this material related to user diversity.

## ***Operation***

Computer workstation components, either separately or in combination with supporting software, should facilitate diverse users' ability to operate the device by

- Not limiting the ability to use alternate methods of carrying out the device functions, for example, assistive technologies
- Minimizing the likelihood of accidental activation
- Supporting error recovery
- Support varying rates of user-provided input, for example, keying rate

## ***Understanding***

Computer workstation components, either separately or in combination with supporting software, should facilitate diverse users' ability to

“Apprehend the manner or method of using the device.”

Finally, the United States Federal Government has established accessibility criteria to be used when purchasing computer workstation components. These criteria are described in Section 508 of the US Rehabilitation Act. Similarly, the International Standards Organization (ISO) has developed a Draft International Standard (ISO 9241-20), which addresses accessibility of computer workstations. At the time of this revision, there are no known conflicts between the accessibility content of these documents (Section 508 and ISO 9241-20) and the content of this document.

Because the form and functionality of computer workstations recognized in this standard vary substantially, the standard presents specifications for a generic workstation and for specific user-interface components (i.e., input devices, visual displays, and furniture) used in that workstation. These specifications are contained in four subsequent chapters:

- Chapter 5, Installed Systems
- Chapter 6, Input Devices
- Chapter 7, Visual Displays
- Chapter 8, Furniture

General scope statements for each of these chapters are presented below. The individual chapters contain detailed scope statements, which discuss assumptions and limitations of the specifications contained therein.

Chapter 5, Installed Systems, addresses human factors specifications for configurations of installed and functioning workstations and for their immediately surrounding ambient environments. These specifications provide guidance to system integrators and apply to the effects of computer workstations on ambient conditions in designed indoor office environments used for the regular conduct of computer-based tasks. The specific work issues considered in this chapter include

- Layout of computer components
- Lighting
- Acoustical noise
- Temperature
- Ventilation

- Equipment emissions
- Mechanical vibrations
- Electrical interference

Chapter 6, Input Devices, identifies human factors specifications for keyboards and auxiliary input devices used in computer workstations. This standard does not address the design of typewriters or handheld computer-based devices. The specific input devices considered in this chapter include

- Keyboards
- Mouse and puck devices
- Trackballs
- Joysticks
- Stylus and light pens
- Tablets and overlays
- Touch-sensitive screens

Chapter 7, Visual Displays, provides specifications for visual display monitors used in computer workstations. These specifications apply to cathode ray tube (CRT) and flat-panel displays, that use monochromatic or color technologies to render at least 100 alphanumeric characters simultaneously. This standard does not address design specifications for projection, head- and helmet-mounted display, or so-called near-eye display technologies. The specific visual display devices considered in this chapter include

- Color and monochrome CRTs
- Color and monochrome flat-panel displays

Chapter 8, Furniture, presents specifications for work surfaces, seating, and selected auxiliary components. These requirements apply to designed workplaces in which users perform computer-based tasks within the range of four reference postures. This standard does not specify or advocate one particular posture for the seated or standing users of computer workstations. Rather, a range of common postures is recognized to encourage changes of posture. The specific furniture components considered in this chapter include

- Monitor support surfaces
- Input device support surfaces
- Operator work surfaces
- Chairs
- Operator supports

## 2.1 Guiding Principles

The specifications presented in this standard are intended to aid operator performance in tasks performed on computer workstations. The specifications support the following human factors and ergonomics objectives:

- Enhance workstation usability by improving ease of use and ease of learning
- Facilitate user performance by encouraging task proficiency and error recovery
- Accommodate users of various physical sizes and expertise levels

- Maintain user performance by allowing postural changes that minimize static loads
- Promote user satisfaction by fostering product acceptance and product usage

## **2.2 Limitations**

Although the information contained in this standard may be generalized to the design, configuration, and use of non-office workstations, the reader is cautioned against generalizing the technical specifications. This standard is not intended to apply to transient computer work situations (e.g., using a laptop computer during airplane travel) or to workstations specially configured for individuals with physical or cognitive disabilities.

However, the use of a portable device in an office setting, such as a laptop computer in a docking station, is specifically understood to be within the scope of this standard and not to be an example of transient computer work.

Furthermore, this standard does not apply to operator health considerations or work practices. Although increased biomechanical efficiency during work periods is desirable from a human factors and ergonomics viewpoint, the focus of this standard is to support operator performance through attention to the design aspects of computer hardware and environment interfaces. No implications are made herein that conformance to this standard produces health-related outcomes.

## 3 CONFORMANCE POLICY

The standard contains two classes of specifications: requirements and recommendations. Requirements are identified by a bold typeface “**shall**,” whereas recommendations are indicated by a bold typeface “**should**.”

The requirements and recommendations represent a consolidation and reduction to practice of the human factors engineering principles for the design and configuration of computer workstations and their components. The requirements and recommendations have been developed from accepted human factors and ergonomics research and established professional practices.

Conformance with this standard can be achieved at either the *component* level or the *system* level. “Component conformance” applies to specific devices used in computer workstations. This compliance level is intended to allow manufacturers of workstation components to meet the objectives of the standard apart from considerations involving the configuration of the installed computer workstation. For example, manufacturers of keyboards need to meet only the applicable requirements in Chapter 6, Input Devices; display device manufacturers need to meet only the requirements in Chapter 7, Visual Displays; and furniture manufacturers need to comply only with the applicable requirements in Chapter 8, Furniture.

“System conformance” applies to the configuration of installed computer workstations. This level of compliance is intended for system integrators and site evaluators to ensure that installed computer workstations meet the objectives of the standard. The system conformance requirements apply to an entire computer workstation. For example, system integrators and evaluators need to meet only the applicable requirements in Chapter 5, Installed Systems, to ensure that the installation of system components supports the range of acceptable configurations.

Evaluations of product conformance with this standard are intended to be performed by professionals who are familiar with and trained in the procedures and measurement techniques involved. To encourage consistency and comparability across conformance evaluations, assessment protocols are presented in each chapter.

Although a workstation and its individual components may comply with the standard when initially configured, the conformance requirements are intended to apply throughout the life cycle of a computer workstation. Systems integrators and evaluators **should** review installed workstations whenever components are added, modified, replaced, or removed.

NOTE: All normative dimensions in this standard are given in SI units (meter, kilogram, seconds). Dimensions given in US customary units such as inches, pounds, etc are presented for advisory purposes only and are non-normative.

### 3.1 Conformance Exclusions

The standard provides specifications for selected components and configurations of computer workstations. The standard does not apply to components and configurations beyond those explicitly mentioned. It is recognized that alternative computer workstation technologies may achieve their functional objectives in an acceptable manner. Thus this standard **shall not** be used to qualify the acceptance, impede the development, or preclude the use of alternative or novel computer workstation components.

Computer workstation components are excluded from the conformance requirements of this standard if their technical design or intended usage falls outside the scope of this standard. It is the responsibility of the component manufacturer or system integrator to establish evidence and documentation for exclusion from this standard.

## 4 CITED STANDARDS

This standard refers to other industry, national and international standards.

ANSI/BIFMA X5.5-1998, *Desk products—Tests*

ANSI/BIFMA X5.9-2004, *Lateral files—Tests*

ANSI/BIFMA X5.3-1997, *Vertical files—Tests*

ANSI/BIFMA X5.1-2002, *General purpose office chairs—Tests*

ANSI/IES RP-1-1993—*American National Standard practice for office lighting*

ANSI S12.2 (R1999)—*American National Standard: Criteria for evaluating room noise* (ASA 115-1995)

BIFMA/CMD-1-2002, *Universal Measurement Procedure for the Use of BIFMA Chair Measuring Device (CMD)*

BIFMA G1 –2002 Ergonomics guideline for VDT (visual display terminal) furniture used in office work spaces

EN563 *Safety of machinery—Temperatures of touchable surfaces: Ergonomics data to establish temperature limit values for hot surfaces*

ISO DIS 9241-20 *Ergonomics of human-system interaction—Part 20: Guidance for the accessibility of information communication equipment and services*

ISO DIS 9241-410 *Ergonomics of human-system interaction—Part 410: Design criteria for physical input devices*



## 5 INSTALLED SYSTEMS

The use of individually compliant workstation components is only part of the process of achieving the productivity and comfort benefits associated with ergonomic VDT workstations. Full realization of these benefits will be achieved only when individual components are effectively integrated into a system that, as a whole, matches the capabilities of the user(s). Simply put, the workstation components as a whole must fit the worker and the work to obtain the desired comfort and productivity benefits.

This chapter presents specifications and guidance to employers and the individuals that they designate to configure computer workstations, also referred to as Video Display Terminals(VDTs), and the immediately surrounding workplace environment for the individual user. These workstations consist of input devices, visual displays, and furniture that individually comply with component specifications stated elsewhere in the standard (i.e., Chapter 6, Input Devices; Chapter 7, Visual Displays; and Chapter 8, Furniture).

**Definition of Employer:** the individual or organization responsible for the proper workstation setup. Typically, the employer will utilize Facility Designers, Interior Designers, Facility Managers, Installers, System Integrators, In-house Health and Safety Professionals, Ergonomists, and so forth, to provide the necessary workstation initial design, setup, adjustments, and maintenance to assure compliance with this standard.

The installation and configuration of ergonomically sound workstations involves several key considerations:

- Employers need to ensure that the individual hardware components, such as support surfaces and chairs, meet their associated design specifications stated elsewhere in this standard.
- Employers need to ensure that the hardware components are compatible with one another when arranged in the actual workstation. This consideration might be characterized by assessments such as “Can this chair be used with this desk?” and “Can this input device be used with this support surface?”
- Employers need to ensure that the configured workstation properly fits the user(s). Some users have body dimensions that lie outside the design ranges used in the equipment specifications of Chapters 6, 7, and 8 of this standard. In such cases the specifications and guidance of this chapter may be of benefit in configuring workstations to suit these individual needs.
- Employers need to ensure that users are informed about the proper use and adjustment of the workstation components. Users’ knowledge of the workstation capabilities needs to include an understanding of the underlying human factors and ergonomics objectives achieved and to be maintained in the configuration of the component devices.
- Note: An employer is defined as the individual or organization responsible for the proper workstation set up. Typically, the employer will contract with Facility Designers, Interior Designer, Facility Managers, Installers, System Integrators, In-house Health and Safety Professionals, Ergonomists, etc., to provide the necessary workstation initial design, set up, adjustments, and maintenance to assure compliance with this standard.
- Improperly configured workstations will likely fail as a system to achieve a good fit with the individual user’s requirements, regardless of the compliance of individual hardware components. Thus the specifications in this chapter stem from a systems engineering perspective and are intended to foster compatibility among components when installed and configured into a computer workstation.

## 5.1 Purpose and Scope

The purpose of this chapter is to provide specifications and guidance to individuals who have responsibilities for acquiring, installing, and integrating computer workstations. These individuals need to recognize and understand the interdependencies among the individual workstation components.

The scope of this chapter covers the configuration of workstation hardware components, lighting, acoustics, temperature, ventilation, and product emissions.

Specifications as to the design of individual hardware components are not presented in this chapter. The reader is directed to use Chapter 6, Input Devices; Chapter 7, Visual Displays; and Chapter 8, Furniture, as companion specifications when considering the design of the individual hardware components.

## 5.2 Design Specifications

### 5.2.1 GENERAL SPECIFICATIONS

This standard recognizes that VDT users frequently change their working postures to maintain comfort and productivity. Four reference postures are used in this standard to represent a range of postures observed at computer workstations (see Figure 5-1).

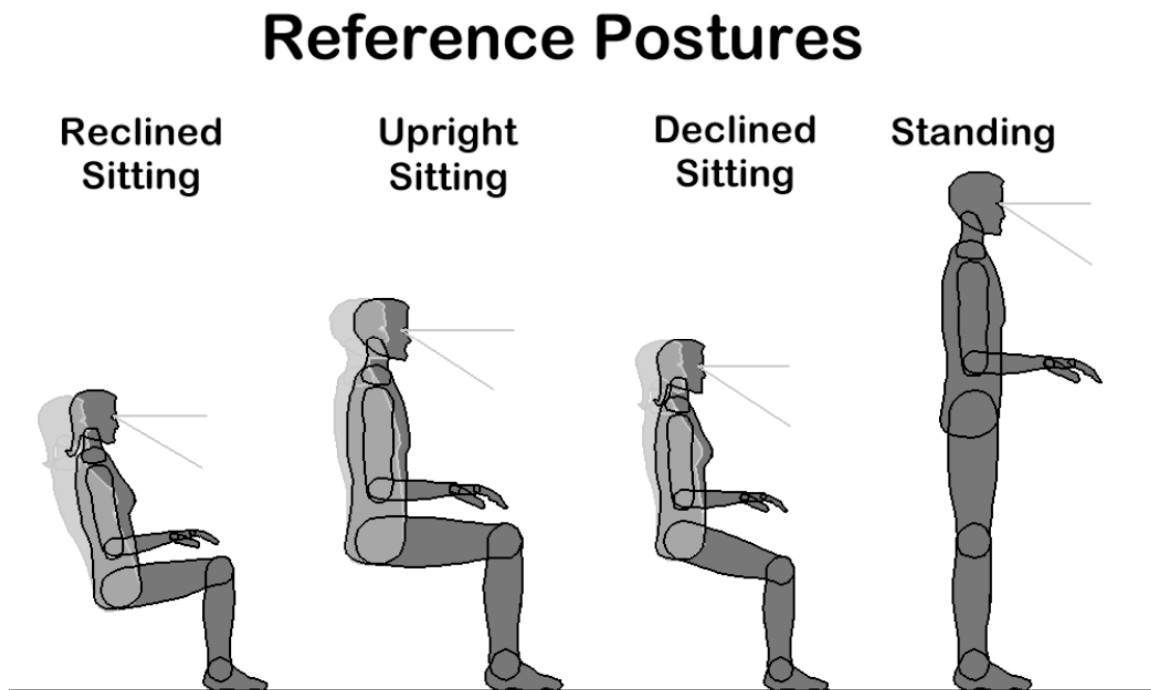

Figure 5-1. Reference postures for computer workstation users.

The four reference postures are characterized as the following:

**Reclined sitting.** In the reclined sitting posture, the user's torso and neck recline between 105 and 120 degrees to the horizontal.

**Upright sitting.** In the upright sitting posture, the user's torso and neck are approximately vertical and in line (between 90 and 105 degrees to the horizontal), the thighs are approximately horizontal, and the lower legs vertical.

**Declined sitting.** In the declined sitting posture, the user's thighs are inclined below the horizontal, the torso is vertical or slightly reclined behind the vertical, and the angle between the thighs and the torso is greater than 90 degrees.

**Standing.** In the standing posture, the user's legs, torso, neck, and head are approximately in line and vertical.

Users require frequent movement and postural changes to achieve and maintain comfort and productivity (Kroemer, Kroemer, & Kroemer-Elbert, 1994; Sanders & McCormick, 1993). The four reference postures are intended to illustrate the diversity of body positions observed at computer workstations. Because these reference postures are intended as examples of human postures, variations in actual postures observed during work sessions can be expected. However, not all postures are equally comfortable or productive.

### 5.2.1.1 User Postures

The installed workstation **shall** allow users to adopt postures within the following reference postural design criteria:

- Elbow angles between 70 and 135 degrees (Cushman, 1984; Grandjean, Hunting, & Pidermann, 1983; Miller & Suther, 1981; Weber, Sancin, & Grandjean, 1984) (Figure 5-2)
- Shoulder abduction angles less than 20 degrees (Chaffin & Andersson, 1984; Karlqvist, Hagberg, Köster, Wenemark, & Ånell, 1996) (Figure 5-3)
- Shoulder flexion angles less than 25 degrees (Chaffin & Andersson, 1984) (Figure 5-4)
- Wrist flexion angles less than 30 degrees (Hedge, McCrobie, & Morimoto, 1995; Rempel & Horie, 1994) (Figure 5-5)
- Wrist extension angles less than 30 degrees (Hedge et al., 1995; Weiss, Gordon, Bloom, So, & Rempel, 1995; Rempel & Horie, 1994)
- Torso-to-thigh angles equal to or greater than 90 degrees (Chaffin & Andersson, 1984) (Figure 5-6)

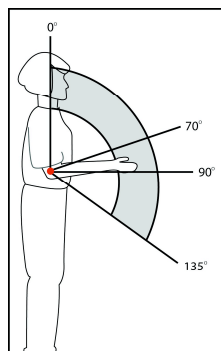
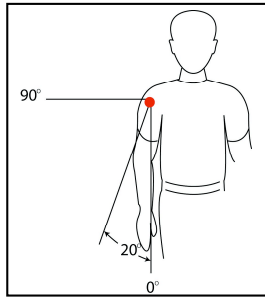
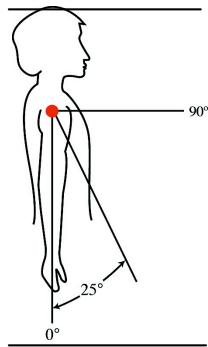

Figure 5-2. Elbow reference postures.



**Figure 5-3. Shoulder abduction reference postures.**



**Figure 5-4. Shoulder flexion reference postures.**

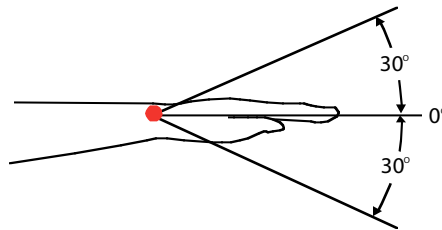

**Figure 5-5. Wrist flexion and extension reference postures.**

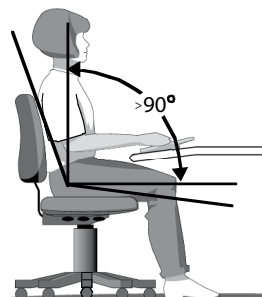

**Figure 5-6. Torso-to-thigh reference postures**

There is wide variation in physical size among the working population. For example, there is a difference of 34 cm (13.4 inches) in height between a small woman and a tall man in the anthropometric database (Gordon et al, 1989) used in this standard. Moreover, personal work styles, fluctuation in task content throughout the workday, and worker physiology all dictate variation in working posture. This combined variation of size and posture, if not accounted for in the design of equipment, results in a mismatch between the user and equipment and, in turn, inefficiencies in the work process (Chaffin, 1984). Such work inefficiencies can add as much as 2% to 22 % to task performance times (Dainoff, 1990; Niebel, 1984).

These postural guidelines are appropriate for all users. Consequently, they may be used for guidance when the individual user is outside the range of sizes that the equipment specifications in this standard have been designed to accommodate.

### **5.2.1.2 Adjustment Controls in the Workstation**

Controls used for the adjustment of workstation components **shall not**

- Intrude into the leg and foot clearance spaces when not in use
- Interfere with users' typical work activities

Controls that conform to the users' expectation for function, method of operation, and location and that are easy to identify, manipulate, and access from the reference postures facilitate movement (Burandt & Grandjean, 1963; Kleeman & Prunier, 1980; Lueder, 1994; Shute & Starr, 1984; Winkel & Oxenburgh, 1990).

Elderly or disabled users may have special requirements with regard to adjustment controls. Some considerations for these user groups are:

- Inadvertent activation of controls while tactilely locating and identifying the control or controls
- Ability or inability to use two hands for control activation
- Limits on the ability to exert force, or the ability to grasp, pinch, or twist the wrist
- Ability to discern the status of locking or toggle controls through touch or sound

### **5.2.1.3 Adjustable Surfaces**

Adjustable workstation surfaces **shall**

- Use a fail-safe mechanism to prevent inadvertent movement
- Use a control locking mechanism to prevent inadvertent operation

Adjustable surfaces that hold heavy objects, such as a visual display, can present a hazard to users. For example, adjustable surfaces moving relative to each other may create pinch-point hazards, either while in operation or in the event of failure.

Elderly or disabled users may have special requirements with regard to adjustment surfaces. Some considerations for these user groups are:

- Accessibility for individuals in wheelchairs

#### 5.2.1.4 Pinch Points

Pinch points, in which fingers, arms, and legs can be caught between movable surfaces or parts, **shall**

- Be avoided by means of design or guarding

In adjustable workstation furniture, surfaces move relative to one another. This may lead to pinch-point hazards in which fingers, arms, or legs can be caught between moving surfaces or parts. This can occur, for example, when a motorized work surface moves past a fixed surface or when clearance between a seat adjustment lever and the bottom of the seat is inadequate. The size of the clearance gap necessary to avoid pinch points will depend on which limb might be involved, but it can be determined with reference to the appropriate 95th percentile male dimension.

The recommended hierarchy of procedures to avoid pinch points is to

- Design to eliminate the hazard
- Guard against the hazard
- Provide warning labels and instructions to users for safe operation

#### 5.2.1.5 Device Cabling

Cables that connect to devices in the workstation **should**

- Be placed to avoid interference with the operation of workstation components
- Be placed to avoid creating hazards for people or equipment in the workstation

Poorly installed cables can present hazards, cause unintended motion of input devices, and/or limit device usage. The characteristics of cables to consider in the workstation configurations include length, weight, tension, flexibility, and location.

### 5.2.2 BENEATH THE WORK SURFACE

#### 5.2.2.1 Leg and Foot Clearance

The installed system **shall**

- Provide adequate leg and foot clearance in the chosen reference posture or postures

The installed system **should not**

- Hinder the foot, leg, or knee in alternative or auxiliary (non-VDT) work positions

Providing adequate clearance under the work surface to allow users to change posture during work periods is a cardinal principle in human factors and ergonomics (Pheasant, 1986). *Adequate clearance* is defined as sufficient clearance to allow the user to assume the desired working position without unintentionally touching workstation components.

The important dimensions under a work surface are sufficient height for leg clearance; sufficient width for hip, leg, and foot clearance; and sufficient depth for knee and foot clearance. Chapter 8 (Section 8.3.2.0, Operator Clearances) gives dimensional specifications for leg and foot clearance necessary to accommodate a population ranging in size from a 5th percentile female to a 95th percentile male in all four of the reference positions.

### 5.2.2.2 Footrests

Footrests **shall**

- Be provided when the range of adjustment of the chair, work surface, or both, does not permit the person's feet to be supported on the floor

A chair with a seat pan that is too high commonly results in a concentration of pressure on the popliteal area at the back of the knee (Chaffin & Andersson, 1984). Appropriate height adjustment and rounded edges on the front of the seat pan facilitate reduction of pressure in the popliteal area. When this is not feasible, as when there is an insufficient range of height adjustment to accommodate an individual, footrests can act to relieve the popliteal pressure by providing the needed support to the feet.

Footrests are necessary postural supports for users when the adjustment ranges of the chair, work surface, input device support surface, and display support surface do not allow the user's feet to be supported by the floor in the relevant reference postures. Moreover, adjustable footrest heights will accommodate a broader range of users and reference postures—the tallest footrest is determined by a female user with the smallest popliteal height sitting in a chair that is adjusted to its maximum seat height.

## 5.2.3 IN FRONT OF THE WORK SURFACE

### 5.2.3.1 Chairs

The chair used to support the user at the workstation **shall**

- Have a lumbar support
- Have a backrest that reclines
- Have a seat pan that adjusts for height and tilt
- Support at least one other of the seated reference postures in addition to the upright sitting posture
- Provide support to the user's back and thighs in the chosen reference postures

The system integrator **should**

- Verify that the chair can be adjusted to provide clearance under the work surface
- Provide information to the user as to the recommended use and adjustment of the chair

Utilizing a chair that complies with the specifications of Chapter 8, Furniture, allows the use of at least two of the three seated reference postures. This facilitates use of multiple working postures.

### 5.2.3.2 Chair Casters

Castors on the chair used to support the workstation user **should**

- Be appropriate for the type of flooring at the workstation

Chair casters and flooring interact with one another to affect the mobility and safety of seated operators. Chair casters that are matched properly to flooring allow operators to change position without having to assist with their arms or to push so hard that the chair reclines. Mismatched chair casters and flooring increase users' efforts to push, pull, or maneuver the chair and may cause inadvertent chair movements while users are sitting down or rising. Generally, hard-wheel chair

casters are used on soft flooring, such as carpeting, whereas soft-wheel chair casters are used on hard flooring, such as wood, concrete, or tile. Regular maintenance of casters is critical for continued acceptable performance.

### 5.2.3.3 Chair Seat Pan and Backrest Adjustments

The seat pan of the chair used to support the workstation user **shall**

- Be height adjustable
- Have a user adjustment for tilt

NOTE: “User adjustment for tilt” is defined as any method of activating the movement of the seat pan/backrest. This can be either through the use of manual devices (levers, knobs, adjustments, etc.) or by movement of the body/body weight.

The seat pan of the chair used to support the workstation user **should**

- Be wide enough to accommodate the clothed hip width of a 95th percentile female
- Be of sufficient depth to allow the user’s back to be supported by the backrest without contact between the back of the user’s knee and the front edge of the seat pan
- Have a tilt lock or stop position that the user can select while seated, if a tilt lock is provided (a stop limits motion in one direction, whereas a lock limits movement in two directions)
- Have a rounded front edge

The backrest of the chair used to support the workstation user **shall**

- Not constrain the user’s torso to a position forward of vertical
- Not force a torso-thigh angle less than 90 degrees
- Allow adjusting the angle between the backrest and seat pan to an angle of 90 degrees or greater
- Allow the user to recline at least 15 degrees from the vertical

The backrest of the chair used to support the workstation user **should**

- Allow the user to control the resistance necessary to recline the backrest
- Provide support to the lumbar and thoracic regions of the back

The chair **should**

- Have a means of adjusting the backrest tension

A seat pan that is too high precludes using the floor for support of the feet and legs. This commonly results in a concentration of pressure on the popliteal area at the back of the knee (Chaffin & Andersson, 1984). Appropriate height adjustment and rounded edges on the front of the seat pan facilitate reduction of pressure in the popliteal area.

Conversely, a seat pan that is too low raises the legs and thighs off the seat pan and concentrates pressure on a small portion of the buttocks overlying the ischial tuberosities (Chaffin & Andersson, 1984). A seat pan that is too low may also increase the likelihood of awkward postures such as arm



flexion, shoulder abduction, and reduced thigh-torso angles (hip flexion) and thereby degrade user comfort and/or performance.

Torso-thigh angles less than 90 degrees increase compressive loading on the disc of the spine, increase the loading on back muscles, and produce uncomfortable pressure concentrations on the thighs (Chaffin & Andersson, 1984). Similarly, provision of lumbar support decreases compressive loading of the spine (Chaffin & Andersson).

Seat pan and backrest adjustment characteristics vary among chairs. Some chairs have an automatic mechanism linking seat pan tilt with the backrest. In others, the user must independently adjust the angle for both.

The backrest's function is to support, or counteract, the force attributable to the action of gravity on the mass of the torso. Adjustments that increase or decrease the tension on the backrest allow it to act as a spring with variable stiffness, supporting greater or lesser amounts of torso weight. Tension adjustment is necessary to accommodate users with different masses and to accommodate user preferences as to how much of their torso weight the chair will support in the selected working posture. This is commonly achieved by means of a user-adjustable control, although some chairs may sense body mass and adjust backrest tension accordingly.

#### **5.2.3.3.1 Armrests**

If provided, the armrests of the chair used to support the workstation user **shall**

- Provide sufficient clearance to allow the user to sit or stand without interference
- Not cause the user to violate any of the postural guidelines specified in Section 5.2.1.1, User Postures

If provided, the armrests of the chair used to support the workstation user **should**

- Be adjustable in height
- Allow adjustment of the clearance width between the armrests
- Be detachable

This standard does not require the use of armrests on chairs but suggests leaving the decision of whether or not to utilize them with the user or system integrator.

Practically, sufficient clearance between the armrests allows the user's hips to pass between them while moving from sitting or standing without touching the armrests.

Support for the arms reduces the loading of the spinal and shoulder muscles (Chaffin & Andersson, 1984) and assists in entering or leaving the chair.

If the armrests are too high, they will force the user to raise and abduct the shoulders. Shoulder abduction increases the likelihood that the user will experience discomfort (Karlqvist et al., 1996).

Armrests that are too widely separated force the user to abduct the shoulder, increasing the likelihood of user discomfort. Similarly, armrests that are too high or too low commonly lead to awkward postures. Finally, armrests may be so large as to force the user to sit far away from the input devices, resulting in undesirable extended reaches and/or other awkward postures.

#### **5.2.3.4 Input Device Location**

For both seated and standing work, the input-device support surface **shall**

- Adjust in height, or a combination of height and tilt, to allow placement of the input device within the recommended space
- Provide adequate leg and foot clearance
- Provide adequate space for multiple input devices (e.g., keyboard and mouse)

For seated work, the input-device support surface **shall**

- Allow the user to work in at least **two** of the reference postures without compromising the postural design criteria described in Section 5.2.1.1, User Postures

If detachable, the input-device support surface **should**

- Be marked to specify the range of adjustment for height and tilt

For sit/stand work, the input device support surface **shall**

- Accommodate at least one of the three seated reference postures in addition to the standing reference posture described in Section 5.2.1 without requiring the user to violate the user postural criteria described in Section 5.2.1.1, User Postures

The recommended space for the location of input devices is a three-dimensional volume defined by reference to the user. The boundaries of the space are swept out by the user's forearm-hand length when the forearms are first held parallel to the horizontal plane and the included elbow angle is then allowed to vary between 70 and 135 degrees. The shoulders are relaxed, the upper arm is approximately vertical, and the elbows are held loosely against the torso with no more than 20 degrees abduction. For seated working positions, the lower limits of the recommended space are determined by thigh clearance. The recommended space is illustrated in Figures 5-7a and 5-7b.

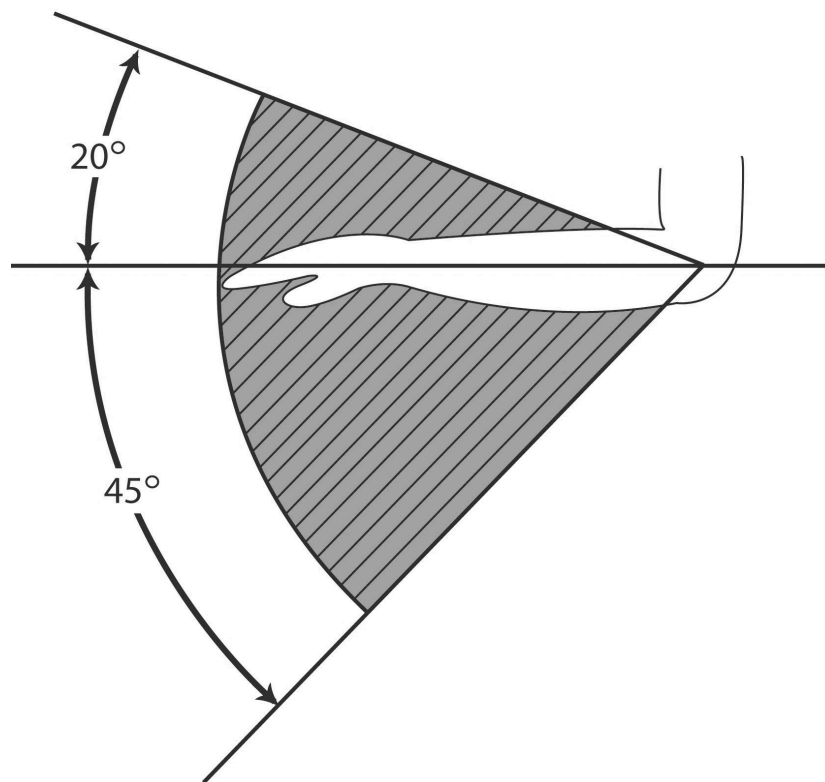

**Figure 5-7a. Side view of recommended space (shaded area) for placement of input devices**

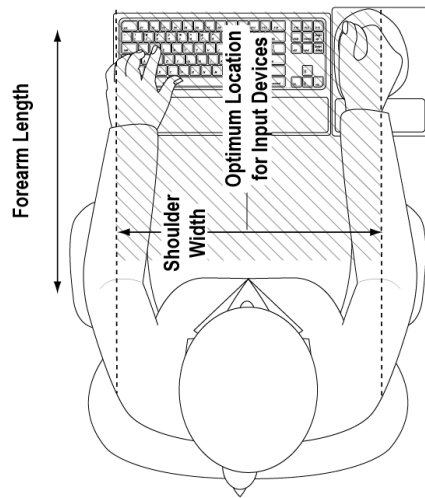

**Figure 5-7b. Top view of recommended space (shaded area) for placement of input devices.**

Research suggests that input devices are most comfortable to use and place less demand on the user when they are located so as to minimize shoulder abduction (Cook & Kothiyal, 1998; Harvey & Peper, 1997; Karlqvist et al., 1996; Paul & Nair, 1996). This is achieved when the devices are approximately located within the shoulder span of the user and within forearm reach. Similarly, users report equal comfort and productivity for a wide range of elbow angles (Cushman, 1984; Grandjean et al., 1983; Miller & Suther, 1981; Weber et al., 1984). Adjusting the height and tilt of support surfaces for input devices may be necessary to facilitate neutral wrist posture (Berqvist, Wolgast, Nilsson, & Voss, 1995; Hedge & Powers, 1995; Karlqvist, 1998).

This standard specifies a location for input devices. Work surface space, if used as input device support, would need to be at least wide enough to support the input devices in the recommended space but may be wider to accommodate other work tasks.

### **5.2.3.5 Arm and Wrist/Palm Supports**

For tasks requiring prolonged use or precise control of input devices, supports **should**

- Be provided for the user's forearms and/or wrists/palms
- Adjust in height and tilt
- Attain the wrist and arm postural design criteria specified in Section 5.2.1.1, User Postures

Research has indicated that these devices are beneficial to performance when configured and used properly (Andersson & Ortengren, 1974; Erdilyi, Sihvonen, Hilin, & Hanninen, 1988; Schuldt, 1988).

Opinions vary regarding the use of wrist/palm supports. However, rests for the wrist/palm and forearm have been shown to reduce muscle activity and to facilitate more neutral wrist angles when used

appropriately (Albin, 1997; Damann & Kroemer, 1995; Feng, Grooten, Wretenberg, & Arborelius, 1997; Grandjean, 1987).

Wrist/palm supports that are less than 3.8 cm (1.5 in.) deep (see Figure 5-8) may not be appropriate as they may cause increased contact pressure (Paul & Menon, 1994). Wide, flat surfaces (>3.8 cm; 1.5 in.) for wrist/palm supports are recommended.

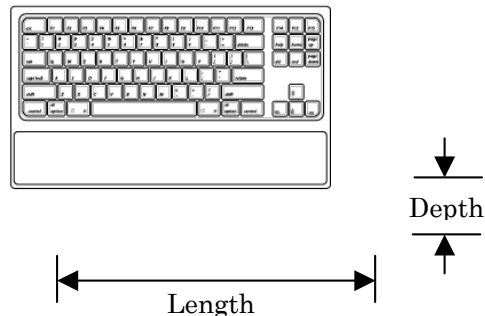

**Figure 5-8. Nomenclature for wrist/palm support dimensions.**

## **5.2.4 ON TOP OF THE WORK SURFACE**

### **5.2.4.1 Horizontal Work Envelope**

When located on the horizontal surface, the input devices **shall** be

- Located as specified in 5.2.3.4

The horizontal work envelope **should**

- Accommodate the user postural design criteria described in Section 5.2.1.1, User Postures
- Be at least 70 cm (27.6 in.) wide

The most commonly used objects **should**

- Be located in the primary work zone

The primary work zone (illustrated in Figure 5-9) is the shape swept out on the work surface by rotating the forearm horizontally at elbow height. Arm motions within this area reduce the physiological cost of movement and improve movement speed and accuracy (Konz & Johnson, 2000).

Space requirements must be determined by analyzing the task requirements. The suggested range of minimum widths for normal work activity is comparable to the 95th percentile male forearm-to-forearm breadth plus a 7.5-cm (3-in.) movement allowance. A work surface of minimum width would not be appropriate for tasks that require space for equipment other than the VDT.

This standard specifies a location for input devices. Work surface space, if used as input device support, would need to be at least wide enough to support the input devices in the recommended space but may be wider to accommodate other work tasks.

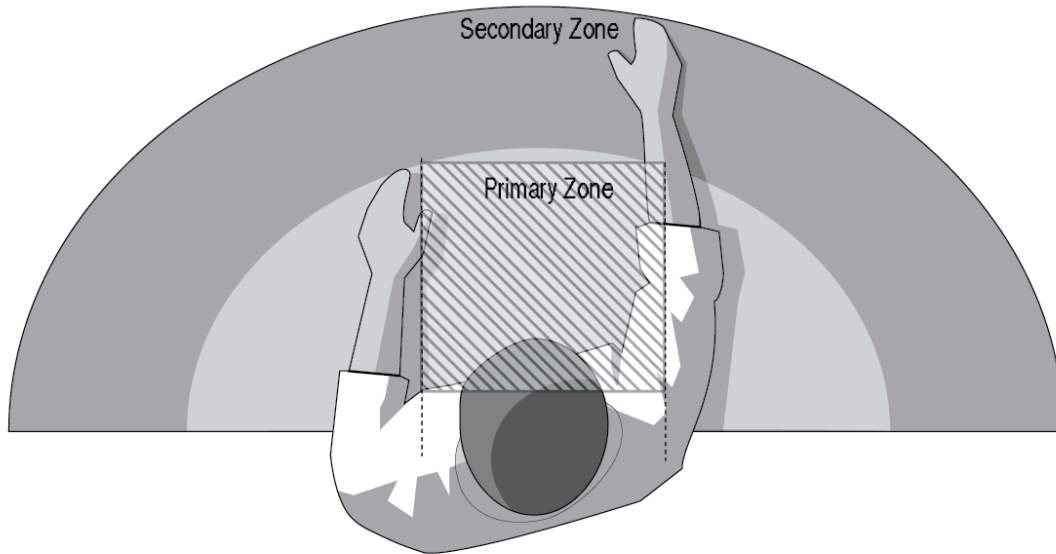

**Figure 5-9. Recommended space for input devices and primary, secondary, and tertiary horizontal work zones.**

#### 5.2.4.2 Monitor Support Surface

The visual display support surface **shall**

- Allow users to adjust the line-of-sight (viewing) distance between their eye point and the front (first) surface of the viewable display area
- Allow users to adjust the tilt and rotation angle between their eye point and the front (first) surface of the viewable display area

The visual display support surface **should**

- Allow users with normal visual capabilities to adjust the line-of-sight (viewing) distance between their eyes and the front (first) surface of the viewable display area within the range of 50 to 100 cm (19.7 to 39.4 in.)

Viewing conditions are based in part on the visual effort needed to accommodate and converge on the viewable display surface at close distances. Near work causes the eyes to converge and the lenses to accommodate. This causes the extraocular and ciliary muscles of the eye to contract and maintain contraction (Turville, Psihogios, Ulmer, & Mirka, 1998). This is thought to contribute to visual discomfort in VDT workers. Studies indicate that users with normal visual capabilities often report greater visual fatigue for viewing distances of 50 cm than for 100-cm viewing distances (Jaschinski-Kruza, 1990), and these observers often consider 50-cm distances too close (Jaschinski-Kruza, 1988, 1990, 1991).

These design limits, however, may need to be shortened for users of some flat-panel display workstations or for users with low visual capabilities, given that they may need closer viewing distances (even less than 40 cm [15.7 in.]) to achieve acceptable postures and viewing. Nevertheless, it is often advantageous to locate frequently viewed surfaces at or near the same optical distance to minimize visual fatigue.

Optimal viewing of a visual display is influenced by numerous factors in the workstation, such as the physical image quality of a monitor (resolution, addressability, pixel shape, subpixel arrangement, luminance and color contrast, viewable screen size), the screen information layout and font characteristics (typeface, font size), the user's posture (angular alignment to screen), visual capabilities (optometric corrections), and the ambient light conditions (screen illumination, glare, reflections). Display-support surfaces that allow adjustment of the alignment between the user and the viewable screen area during a work session are essential to achieving optimal viewing conditions.

A common approach to achieving optimal viewing conditions often begins by ensuring that the physical image quality of the screen is appropriate for the workstation environment. One important factor has been to ensure that the viewing distance allows alphanumeric characters rendered on the screen (in their primary or default font) to subtend at least 16 arc minutes of visual angle (2.3 mm at 50 cm viewing distance; 0.1 in. at 19.7 in.). This minimum character size is necessary to ensure legibility (Snyder & Maddox, 1978) and it should be increased to at least 20 to 22 arc minutes for readability.

### 5.2.4.3 Monitor Viewing Angle

The center of the visual display screen **should**

- Be located 15 to 25 degrees below horizontal eye level

During work periods, display screens **should not**

- Be located more than 35 degrees off axis (i.e., from the user's predominant line of sight) while the user is gazing straight ahead

The entire visual area of a visual display terminal workstation, including items other than the display such as the keyboard, **should**

- Be located between 0 degrees (horizontal eye height) and 60 degrees below eye height when users assume the upright sitting, reclined sitting, declined sitting, or standing reference posture

The vertical height of a VDT screen represents a compromise between minimizing visual discomfort and musculoskeletal discomfort of the neck and shoulders. In general, lowering a screen or increasing the viewing distance will reduce visual discomfort. However, lowering the screen increases the loading on neck and shoulder muscles. Display screen height above eye level has also been associated with musculoskeletal discomfort.

Research findings indicate that viewers prefer downward gaze angles for near work (Heuer, Breuwer, Roemer, Kroger, & Knapp, 1991; Hill & Kroemer, 1986), whereas upward gaze angles—especially those involving backward tilting of the head—cause discomfort. Several researchers found that downward gaze angles lead to reduced eyestrain and visual fatigue (Owens & Wolf-Kelly, 1987; Tyrell & Leibowitz, 1990), improved accommodation and vergence for close work (Heuer & Owens, 1989), and reduced evaporation of the tear layer (Tsubota & Nokamori, 1993).

However, other researchers have found that gaze angles greater than 35 degrees result in increased muscle loading (Turville et al., 1998; Sommerich, Joines, & Psihogios, 2001). Long periods of work requiring sustained forward tilt of the head by 30 degrees or more can cause discomfort (Chaffin, 1973). Because users may not rotate their eyes comfortably more than 30 degrees downward (in relation to their head position) during sustained viewing, gaze angles lower than 60 degrees for long periods may cause discomfort.

Horizontal eye level to screen center angles of 15 to 20 degrees at distances of 75 to 83 cm (29.5 to 32.7 in.) appear to be a reasonable compromise (Sommerich et al., 2001). Allie, Purvis and Kokot

(2005) suggest placing the top of the viewing area 5 degrees below horizontal eye level, with the center of the screen 25 degrees below horizontal eye level is an appropriate “middle ground” between visual and musculoskeletal demands.

#### **5.2.4.4 Document Holders**

Document holders **should**

- Allow placement of materials adjacent to the monitor and at approximately the same height, distance, and angle relative to the user’s eyes as the monitor screen
- Be stable when loaded with the intended materials

Adjustable document holders allow users to read and/or transcribe hard-copy materials without assuming awkward postures (Bauer & Wittig, 1998). Placing the hard-copy materials at a distance from and angle to the user similar to those of the monitor minimizes changes in visual accommodation and vergence, thereby reducing visual effort.

### **5.2.5 SURROUNDING THE WORK SURFACE**

#### **5.2.5.1 Illuminance**

Workplace illumination **shall**

- Not degrade the image quality on the display

NOTE: Chapter 7 provides further information regarding image quality

Workplace illumination **should**

- Be sufficient for the effective performance of the required task
- Range between 200 and 500 lux (18.6 to 46.5 foot-candle) on the work surface for light-emitting displays

In general, ambient illuminance should be sufficient to support the visual tasks that will be done at the computer workstation or on associated paper documents. Reading blueprints, for example, requires relatively high illuminance on the document (as high as 1000 lux (93 foot-candle) to ensure comfortable viewing. A task light is a solution in such an instance. Task lights need to be positioned carefully to avoid causing glare on the computer display. An adjustable fixture that allows the user to change the direction of the light is recommended so that glare on the display is minimized.

Below 100 lux (9.3 foot-candle) , the user’s ability to read printed paper may be impaired. This finding is especially true for older workers, who need more light to read comfortably than do younger ones. Illuminance levels between 200 and 500 lux are sufficient for standard visual tasks (Illuminating Engineering Society, 1993). These tasks include reading printed text and text on a CRT display.

When specifying the illuminance levels at the workstation, it is important to consider the display technologies that will be used in those environments. High illuminance at emissive computer workstation screens, such as CRT displays, can reduce character contrast and impair visual performance. An upper limit of 500 lux for ambient lighting is recommended to maximize screen visibility for these types of displays (Illuminating Engineering Society, 1989, 1993).

Unwanted light may be controlled by positioning light sources, use of window shades, glare screens, and so forth.

### 5.2.5.2 Luminance Balance

Luminance from environmental sources in the user's field of view that are greater than 5 degrees of arc **should**

- Not exceed 10 times the average screen luminance for negative-polarity screens (bright characters on dark background)
- Not exceed 3 times the average screen luminance for positive-polarity screens (dark characters on bright background)

Correct luminance balance in a workstation allows comfortable viewing of the display. Properly balanced luminance sources produce a visual environment in which bright spots do not distract the user.

For negative-polarity screens, surround luminances that are brighter than the screen average luminance result in the best visual performance. Under these conditions, visual performance is not degraded until the background luminance approaches 100 times the average screen luminance. The best visual performance occurs when the background luminance is approximately 5 times the average screen luminance.

For positive-polarity screens, the best visual performance is obtained when the background luminance is approximately equal to the average screen luminance. Under these conditions, visual performance is not degraded substantially until the background is more than 20 times the average screen luminance.

### 5.2.5.3 Acoustical Noise

The maximum level of background noise emission from a computer workstation and its components **should**

- Have Balanced Noise Criteria (NCB) rating ranging between 38 and 43

The ideal general recommendation is to strive to achieve an NCB rating within the range as low as possible. Higher NCB ratings should be used only when economic circumstances dictate.

The NCB values given assume occupied spaces, with heating/ventilation/air conditioning (HVAC) operating and all other sources of normal and interior and exterior noise also operating (ANSI S12.2, 1999). These levels allow oral communication and provide an environment quiet enough to aid concentration on mental tasks. It has been shown that people normally raise their voices about 0.5 dB for every 1 dB increase in the background noise level (Kryter, 1985).

If the background noise levels are higher than desired, noise may be reduced by using carpeted floors, ceiling acoustical tiles, draperies, and sound-absorbing/isolating partitions or other sound-absorbing materials (Kleeman, 1991). Separating noise sources from the work environment with walls or partitions or by covering equipment with an acoustical enclosure also effectively reduces noise.

### 5.2.5.4 Mechanical Vibrations

The stability and function of computer workstation components **should not**

- Be impaired by vibration

Excessive mechanical vibration can adversely affect users' task performance as well as the intended operational levels of the computer workstation components. For example, mechanical vibrations of the visual display can reduce perceived image, and mechanical vibrations of furniture can loosen position adjustment settings. Mechanical vibrations can also cause unwanted noise in the work area.



Examples of vibration sources at computer workstations include components of the workstation (impact printers, cooling fans), structural features of the facility (air-conditioning systems), and nearby equipment and pedestrian traffic in the work area.

### 5.2.5.5 Contact Surface Temperature

Surfaces of the workstation components that the user is expected to touch with bare skin **shall**

- Not exceed the exposure times and temperatures for the surface materials listed in Table 5-1

**Table 5-1. Surface Temperature and Contact Time**

Material	Time/Temperature (degrees Celsius**)				
	1 s	4 s	10 s	10 min	8 h*
Unpainted metal	65	58	55	48	43
Lacquered metal	75	61	55	48	43
Enameled metal	70	60	56	48	43
Ceramic, glass, stone	80	70	66	48	43
Plastics	85	74	70	48	43
Wood	110	93	89	48	43

\* Amount of contact area (more than 10% of skin surface area) or contact with vulnerable structures (such as the airways) invalidates the 8-hour values given here. From EN563 *Safety of machinery—Temperatures of touchable surfaces: Ergonomics data to establish temperature limit values for hot surfaces*.

\*\* Degrees Celsius = 5/9 (Degrees Fahrenheit –32)

Only a few surfaces of the computer workstation and its equipment present thermal contact hazards to users. Surfaces that are intended to be touched, such as the back panel of the computer and connector surfaces, need to be cool enough to avoid skin burns (Parsons, 1993). The values shown are from EN563 (1994).

### 5.2.5.6 Ambient Thermal Conditions

The ambient temperature **should**

- Range between 20° and 23.5° centigrade (68° to 74.3° Fahrenheit) during the heating season and between 23° and 26° centigrade (73.4° and 78.8° Fahrenheit) during the cooling season

The relative humidity of the air in the workstation **should**

- Range between 30% and 60%

The air velocity **should**

- Be less than 20 cm/s (7.9 in./s)

The rate of heat exchange between people and their surroundings is a major factor affecting alertness, comfort, and task effectiveness. The thermal parameters of the computer workstation are not significantly different from those for comfort at office workstations in general. However, any additional heat gain from the computer and its components needs to be considered when designing a computer workstation environment.

In workplaces with relative humidity below 30%, some computer users, particularly those wearing contact lenses, may report dryness of the eyes. This condition may be exacerbated by higher airflow

rates, which also can dry the eyes. It has been shown that users blink less frequently when using a computer, which also dries the eyes (Rosner & Belkin, 1989). To provide an environment that promotes comfortable vision, maintain the relative humidity between 30% and 60% in the computer workstation. At this level, moisture in the air is sufficient for contact lens wearers.

### 5.2.5.7 Product Emissions

The computer and its components **should not**

- Emit pollutants that adversely affect work performance

Computers and their peripherals (e.g., laser printers) may emit chemicals, mainly volatile organic compounds (VOCs), ozone, and particles (Brooks & Davis, 1993). VOC emission rates are directly dependent on the materials used in the manufacture of the product and the chemicals used in the product under normal operating conditions. Maintain ventilation rates of at least 20 cubic feet of air per minute per person in the office to ensure that any harmful substances are removed from the office. Where more than a single unit of a computer workstation is in use or where there is a high density of components (e.g., a printer room with several laser printers and other equipment), additional ventilation beyond that appropriate for a normal office may be warranted, depending on occupancy rates.

Qualitative and quantitative risk assessments can be conducted to determine whether exposure to chemicals emitted during the operation of the computer and its associated components is toxic. To estimate potential toxicity associated with exposure to product emissions, identify potential routes of exposure and exposed workers, identify chemicals for risk assessment, estimate and model the exposure level, and estimate the potential hazards.

### 5.2.5.8 Electromagnetic Compatibility

The magnitude of environmental magnetic fields **should not**

- Exceed the susceptibility of the computer workstation display

The influence of electromagnetic fields on the computer workstation can cause display quality distortions. Environmental magnetic fields arise from power distribution in the building and emission from nearby devices. Surrounding electromagnetic fields less than 200 nanotesla usually will not affect the stability of the display image or the performance of the computer. Consider the placement of the computer and display relative to devices that produce electromagnetic fields that can cause jitter, such as CRT displays, motors, and ballast transformers for fluorescent task lamps.

### 5.2.5.9 Static Electricity

The computer workstation **should**

- Be free of electrostatic potentials in excess of  $\pm 500$  volts
- Be cleaned of statically precipitated dust periodically

Dust particles in the air are often polarized and will orient and accelerate in the presence of an electric field, as is present on the face of a CRT, up to  $7.5 \text{ mm/s}^2$  (Grandjean, 1987). Dust will collect on charged surfaces more quickly than on surfaces where no field is present. Relative humidity in the workstation, the density of air ions, and the particle content determine the rate at which dust will collect on a display.

A dusty screen can exhibit reduced contrast and will present a degraded viewing condition when compared with a similar display free of dust. Another issue is the electric shock, which may occur

when the user contacts a conductive surface. Potentials on either the screen or the user can be discharged very quickly (e.g., 50 ms) to produce a shock. Shocks can be uncomfortable and annoying and can cause unplanned movement of a limb. The energy from these shocks is limited (less than 100 millijoules), so it is not dangerous to the user.

## 5.3 Conformance

### 5.3.1 USER POSTURES

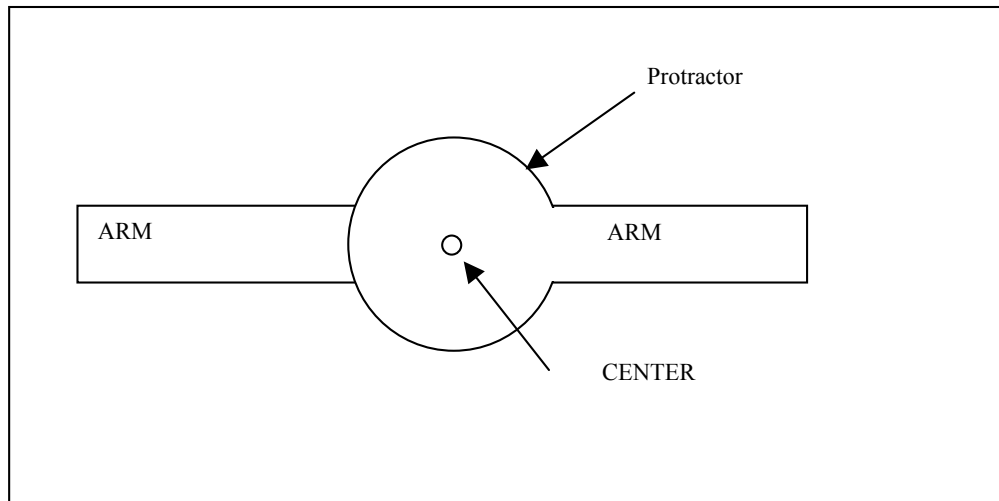

Figure 5-10. Diagram of manual goniometer

**Elbow angle measurement.** To measure the included elbow angle, use a manual goniometer. Place the center of the protractor (axis, or point of rotation) of the goniometer over the lateral epicondyle of the humerus (elbow). Place one arm of the goniometer along the line of the ulna (forearm bone) and the other goniometer arm along the line of the humerus (upper arm bone). Measure and record the angle. Verify that the angle is between 70 and 135 degrees.

**Shoulder abduction angle measurement.** *Abduction of the shoulder* is a term used to mean moving the arm to the side and away from the body. To measure shoulder abduction angle, use a manual goniometer. Place the axis of the goniometer over the posterior aspect of the glenohumeral joint (shoulder joint). Extend one arm of the goniometer laterally along the trunk and parallel to the spine. Extend the second arm of the goniometer along the line of the humerus (upper arm). Measure and record the angle. Verify that the angle is less than 20 degrees.

**Shoulder flexion angle measurement.** Shoulder flexion angle is a measure of the forward reach of the arm. To measure it, use a manual goniometer. Place the axis of the goniometer over the glenohumeral joint approximately 1 inch below the acromion process. Place one arm of the goniometer parallel to the lateral midline of the trunk. Place the other goniometer arm along the line of the humerus (upper arm). The angle between the two arms of the protractor is the angle of shoulder flexion. Measure and record the angle. Verify that the shoulder flexion angle is less than 25 degrees.

**Wrist angle measurement.** To measure wrist flexion and or extension, use a manual goniometer. Place the axis of the goniometer over the center of the styloid process of the ulna (bony lump at outside of the wrist). Align one arm of the goniometer along the line of the ulna (forearm). Place the other goniometer arm parallel to the 5th metacarpal (where the little finger joins the hand).

Measure and record the angle. Verify that the angle is 10 degrees or less if the wrist is extended (bent up) or that the angle is 30 degrees or less if the wrist is flexed (bent down).

**Torso-thigh angle measurement.** To measure the torso-to-thigh angle, use a manual goniometer. Place the axis of the goniometer over the greater trochanter (bony prominence in the hip joint). Place one arm of the goniometer protractor along an imaginary line running up through the center of the user's torso and the second arm along the midline of the femur (upper leg) pointing toward the knee. Measure and record the angle. Verify that the angle is at least 90 degrees.

### **5.3.2 CONTROL CLEARANCE FOR USER'S FEET AND LEGS**

Verify compliance with the leg and foot clearance specifications in Chapter 8. Furniture, Section 8.3.2.1, Operator Clearances.

Observe whether controls, when not in use, inadvertently come into contact with the legs and/or feet. Verify that the controls are in the intended nonuse position.

Observe if controls interfere with the user's ability to perform work activities when the controls are not in use.

### **5.3.3 PINCH POINTS**

Verify that pinch points allow sufficient clearance to avoid pinching the body part likely to be entrapped.

### **5.3.4 LEG AND FOOT CLEARANCE**

The installed system, including the chair, **shall**

- Verify compliance with furniture chapter specifications for leg and foot clearance requirements
- Verify that workstation allows the user to sit in reference postures without any portion of the workstation touching the user's legs and/or feet while he/she is in the selected reference posture or postures

### **5.3.5 FOOTRESTS**

Verify by observation that user's feet are supported on floor or footrest when they are in the selected seated postures and in conformance with 5.2.1.1.

### **5.3.6 CHAIRS**

Verify lumbar support, reclining backrest, seat pan adjustability, and ability to meet two of the three seated reference posture criteria by observation or manufacturer's specifications.

Verify that the chair is correctly adjusted for appropriate leg and foot clearance by applying the criteria from 5.2.1.1.

Verify by observation that the chair supports the user's torso and thighs. Note: The chair's lumbar support should provide support to the low back (lumbar region clearance between the back of the user's legs and the front edge of the chair).

### **5.3.7 CHAIR SEAT PAN AND BACKREST ADJUSTMENTS**

Verify by observation that the backrest and/or seat pan are not adjusted in a manner that positions the user's torso forward of vertical.

Verify that the backrest and/or seat pan of the chair are not adjusted in a manner that forces a torso-thigh angle less than 90 degrees.

Verify by observation or by manufacturer's claim that the angle between the seat pan and backrest can be adjusted to an angle of 90 degrees or more.

Verify by observation or by manufacturer's claim that the chair backrest allows the user to recline at least 15 degrees behind vertical.

### **5.3.8 ARMRESTS**

Verify sufficient clearance between the armrests by observation. Determine whether the user can sit in, or arise from, the chair without the user's hips, buttocks, or thighs touching the armrests. This prohibition against touching the armrests specifically does not include grasping the armrests to assist movement.

Verify that utilizing the armrests of the chair does not cause the user to assume postures that are contrary to the requirements of User Postures specifications. Observe and/or measure the postural angles as described in Section 5.2.1.1 while the user is seated in the chair and using the armrests to support his/her arms.

### **5.3.9 INPUT DEVICE LOCATION**

The recommended space for placement of input devices is directly in front of the user. To determine the recommended space for placement of the input device or devices for any individual user:

1. Determine whether the user's selected working posture conforms to the requirements of Section 5.2.1.1. Particular attention should be given to shoulder abduction, elbow angle, and forearm/wrist angle.
2. Determine the user's shoulder breadth. This may be measured as the distance between the acromial processes or approximated by observation. The distance between the user's shoulders is the width of the recommended space.
3. Determine the length of the user's forearm. This may be measured as the distance from the oleacronon (tip of the elbow) to the tip of the index finger. The recommended space is as deep as the length of the user's forearm.

If the input device(s) is placed within the space delimited by the user's forearm length and shoulder breadth and if the user's working posture conforms with Section 5.2.1.1, the input device(s) is appropriately located with regard to height and tilt.

Evaluation of leg and foot clearances for the input device may be assessed as in conformance Section 5.2.2.1.

Verify that the workstation is adjusted so that the user meets the postural criteria of Section 5.2.1.1 for the selected working postures. Note that conformance requires meeting the criteria.

Verify that the range of adjustment for height and tilt is available.

Verify by observation or from the manufacturer claims that the workstation can be used in at least one of the seated reference postures as well as in the standing posture while maintaining conformance with Section 5.2.1.1.

### 5.3.10 MONITOR SUPPORT SURFACE

Verify that the user can adjust the viewing distance of the monitor by moving it closer to, or away from, the eyes.

Verify that the user can tilt and rotate the display.

### 5.3.11 ILLUMINANCE

The system integrator will generally verify this provision by the absence of noticeable or distracting reflections on the computer screen.

## 5.4 References

- Albin, T. J. (1997). Effect of wrist rest use and keyboard tilt on wrist angle while keying. In *Proceedings of the 13th Annual Congress of the IEA* (Vol. 4, pp. 16–18). Helsinki: Finnish Institute of Occupational Health.
- Allie, P., Purvis, C., & Kokot, D. (2005). Computer Display Viewing Angles: Is it time to shed a few degrees? In *Proceedings of the 49<sup>th</sup> Human Factors and Ergonomics Society Annual Meeting*. Santa Monica, CA: Human Factors and Ergonomics Society.
- Andersson, G. B. J., & Ortengren, R. (1974). Myoelectric activity during sitting. *Scandinavian Journal of Rehabilitation Medicine* (Supplementum 3), 73–90.
- ANSI S12.2 (R1999). (1999). *American National Standard: Criteria for evaluating room noise* (ASA 115-1995). Melville, NY: Acoustical Society of America.
- Bauer, W., & Wittig, T. (1998). Influence of screen and copy holder positions on head posture, muscle activity and user judgement. *Applied Ergonomics*, 29, 185–192.
- Berqvist, U., Wolgast, E., Nilsson, B., & Voss, M. (1995). Musculoskeletal disorders among visual display terminal workers: Individual, ergonomic, and work organization factors. *Ergonomics*, 38, 736–776.
- Brooks, B. O., & Davis, W. F. (1993). *Understanding indoor air quality*. Boca Raton, FL: CRC Press.
- Burandt, U., & Grandjean, E. (1963). Sitting habits of office employees. *Ergonomics*, 6, 217–226.
- Chaffin, D. B. (1973). Localized muscle fatigued—definition and measurement. *Journal of Occupational Medicine*, 15(4) 346–354.
- Chaffin, D. B. (1984). *Engineering anthropometry and occupational biomechanics*. In G. Salvendy (Ed.), *Handbook of industrial engineering*. New York: Wiley.
- Chaffin, D. B., & Andersson, G. B. (1984). *Occupational biomechanics* (pp. 309–311). New York: Wiley.
- Cook, C. J., & Kothiyal, K. (1998). Influence of mouse position on muscular activity in the neck, shoulder and arm in computer users. *Applied Ergonomics*, 29, 439–443.
- Cushman, W. H. (1984). Data-entry performance and operator preferences for various keyboard heights. In E. Grandjean (Ed.), *Ergonomics and health in modern offices* (pp. 495–504). Philadelphia: Taylor & Francis.
- Dainoff, M. (1990). Ergonomic improvements in VDT workstations: Health and performance effects. In S. Sauter, M. Dainoff, & M. Smith (Eds.), *Promoting health and productivity in the computerized office* (pp. 49–67). Philadelphia: Taylor & Francis.
- Damann, E. A., & Kroemer, K. H. E. (1995). Wrist posture during computer mouse usage. In *Proceedings of the Human Factors and Ergonomics Society 39th Annual Meeting* (pp. 625–629). Santa Monica, CA: Human Factors and Ergonomics Society.
- EN563. (1994). *Safety of machinery—temperatures of touchable surfaces: Ergonomics data to establish temperature limit values for hot surfaces*. London: British Standards Institute.
- Erdilyi, A., Sihvonen, T., Hilin, P., & Hanninen, O. (1988). Shoulder strain in keyboard workers and its alleviation by arm supports. *International Archives of Occupational and Environmental Health*, 60, 119–124.

- Feng, Y., Grooten, W., Wretenberg, P., & Arborelius, U. P. (1997). Effects of arm support on shoulder and arm muscle activity during sedentary work. *Ergonomics*, *40*, 834–848.
- Gordon, C. C., Churchill, T., Clauser, T. E., Bradtmiller, B., McConville, J. T., Tebbetts, I., et al. (1989). *1988 Anthropometric survey of U.S. Army personnel: Summary statistics interim report* (Tech. Report NATICK/TR-89-027). Natick, MA: U.S. Army Natick Research, Development and Engineering Center.
- Grandjean, E. (1987). *Ergonomics in computerized offices* (pp. 115–118). Philadelphia: Taylor & Francis.
- Grandjean, E., Hunting, W., & Pidermann, M. (1983). VDT workstation design: Preferred settings and their effects. *Human Factors*, *25*, 161–175.
- Harvey, R., & Peper, E. (1997). Surface electromyography and mouse use position. *Ergonomics*, *40*, 781–789.
- Hedge, A., McCrobie, D., & Morimoto, S. (1995). *Beneficial effects of a preset tiltdown keyboard system on posture and comfort in offices* (Monograph, p. 20). Ithaca, NY: Cornell University.
- Hedge, A., & Powers, J. A. (1995). Wrist postures while keyboarding: Effects of a negative slope keyboard system and full motion forearm supports. *Ergonomics*, *38*, 508–517.
- Heuer, H., Breuwer, M., Roemer, T., Kroger, H., & Knapp, H. (1991). Preferred vertical gaze direction and observation distance. *Ergonomics*, *34*, 379–392.
- Heuer, H., & Owens, D. A. (1989). Vertical gaze direction and the resting posture of the eyes. *Perception*, *18*, 363–377.
- Hill, S. G., & Kroemer, K. H. (1986). Preferred declination of the line of sight. *Human Factors*, *28*, 127–134.
- Illuminating Engineering Society (IES). (1989). *Recommended practice for lighting offices containing VDTs* (IES RP-24-1989). New York: Author.
- Illuminating Engineering Society (IES). (1993). *American National Standard practice for office lighting* (ANSI/IES RP-1-1993). New York: Author.
- Jaschinski-Kruza, W. (1988). Visual strain during VDU work: The effect of viewing distance and dark focus. *Ergonomics*, *31*, 1449–1465.
- Jaschinski-Kruza, W. (1990). On the preferred viewing distances to screen and document at VDU workplaces. *Ergonomics*, *33*, 1055–1063.
- Jaschinski-Kruza, W. (1991). Eyestrain in VDU users: Viewing distance and the resting position of ocular muscles. *Human Factors*, *33*, 69–83.
- Karlqvist, L. K. (1998). A process for the development, specification and evaluation of VDU work tables. *Applied Ergonomics*, *29*, 423–432.
- Karlqvist, L. K., Hagberg, M., Köster, M., Wenemark, K. A., & Ånell, R. (1996). Musculoskeletal symptoms among computer assisted design (CAD) operators and evaluation of a self-assessment questionnaire. *International Journal of Occupational and Environmental Health*, *2*, 185–192.
- Kleeman, W. B. (1991). *Interior design of the electronic office: The comfort and productivity payoff*. New York: Van Nostrand Reinhold.
- Kleeman, W. B., & Prunier, T. (1980). Evaluation of chairs used by air traffic controllers of the U.S. Federal Aviation Administration. In R. Easterby, K. H. Kroemer, & D. B. Chaffin (Eds.), *NATO symposium on anthropometry and biomechanics: Theory and application* (pp. 235–239). London: Plenum.
- Konz, S., & Johnson, S. (2000). *Work design: Industrial ergonomics* (pp. 259–260). Scottsdale, AZ: Holcomb Hathaway.
- Kroemer, K., Kroemer, H., & Kroemer-Ebert, K. (1994). *Ergonomics: How to design for ease and efficiency*. Englewood Cliffs, NJ: Prentice-Hall.
- Kryter, K. D. (1985). *The effects of noise on man* (2nd ed.). Orlando, FL: Academic.
- Lueder, R. K. (1994). Adjustability in context. In R. K. Lueder & K. Noro (Eds.), *Hard facts about soft machines: The ergonomics of seating* (pp. 25–35). Philadelphia: Taylor & Francis.
- Miller, I., & Suther, T. W. (1981). Preferred height and angle settings of CRT and keyboard for a display station input task. In *Proceedings of the Human Factors Society 25th Annual Meeting* (pp. 492–496). Santa Monica, CA: Human Factors and Ergonomics Society.
- Niebel, B. W. (1984). *Time study*. In G. Salvendy (Ed.), *Handbook of industrial engineering*. New York: Wiley.
- Owens, D. A., & Wolf-Kelly, K. (1987). Near work, visual fatigue and variations of oculomotor tonus. *Investigative Ophthalmology and Visual Science*, *28*, 743–749.
- Parsons, K. C. (1993). *Human thermal environments* (p. 228, Figure 11.3). Philadelphia: Taylor & Francis.
- Paul, R., & Menon, K. (1994). Ergonomic evaluation of keyboard wrist pads. In *Proceedings of the 12th Triennial Congress of the International Ergonomics Association* (Vol. 2., pp. 204–207). Toronto, International Ergonomics Association.

- Paul, R., & Nair, C. (1996). Ergonomic evaluation of keyboard and mouse tray designs. In *Proceedings of the Human Factors and Ergonomics Society 40th Annual Meeting* (pp. 632–636). Santa Monica, CA: Human Factors and Ergonomics Society.
- Pheasant, S. (1986). *Bodyspace: Anthropometry, ergonomics and design* (p. 19). London: Taylor & Francis.
- Rempel, D., & Horie, S. (1994). Effect of wrist posture during typing on carpal tunnel pressure. In *Proceedings of Working with Display Units '94* (pp. 27–28). Milan: University of Milan.
- Rosner, M., & Belkin, M. (1989). Video display units and visual function. *Survey of Ophthalmology*, 33(6), 515–522.
- Sanders, M., & McCormick, E. J. (1993). *Human factors in engineering and design* (7th ed.). New York: McGraw-Hill.
- Schuldt, K. (1988). On neck muscle activity and load reduction in sitting postures. *Scandinavian Journal of Rehabilitation Medicine*, 19, 481–494.
- Shute, S. J., & Starr, S. J. (1984). Effects of adjustable furniture on VDT users. *Human Factors*, 26, 157–170.
- Snyder, H. L., & Maddox, M. E. (1978). *Information transfer from computer generated dot matrix displays* (Report No. HFL-78-3/ARO-78-1). Blacksburg, VA: Virginia Polytechnic Institute and State University.
- Sommerich, C. M., Joines, S. M. B., & Psihogios, J. P. (2001). Effects of computer monitor viewing angle and related factors on strain, performance and preference outcomes. *Human Factors*, 43, 39–55.
- Tsubota, K., & Nokamori, K. (1993). Dry eyes and video display terminals. *New England Journal of Medicine*, 328(8), 584.
- Turville, K. L., Psihogios, J. P., Ulmer, T. R., & Mirka, G. A. (1998). The effects of video display terminal height on the operator: a comparison of the 15° and 40° recommendations. *Applied Ergonomics*, 29, 239–246.
- Tyrell, R., & Leibowitz, H. (1990). The relation of vergence effort to reports of visual fatigue following prolonged near work. *Human Factors*, 32, 341–357.
- Weber, A., Sancin, E., & Grandjean, E. (1984). The effects of various keyboard heights on EMG and physical discomfort. In E. Grandjean (Ed.), *Ergonomics and health in modern offices* (pp. 477–483). Philadelphia: Taylor & Francis.
- Weiss, N. D., Gordon, L., Bloom, T., So, Y., & Rempel, D. M. (1995). Wrist position of lowest carpal tunnel pressure and implications for splint design. *Journal of Bone Joint Surgery*, 77A, 1695–1699.
- Winkel, J., & Oxenburgh, M. (1990). Towards optimizing physical activity in VDT/office work. In S. L. Sauter, M. Dainoff, & M. J. Smith (Eds.), *Promoting health and productivity in the office environment* (pp. 94–117). London: Taylor & Francis.



## 6 INPUT DEVICES

This chapter presents design specifications for alphanumeric keyboards and selected non-keyboard input devices used in computer workstations. These specifications, along with those in Chapter 5, Installed Systems, are intended for designers and manufacturers of input devices.

### 6.1 Purpose and Scope

The purpose of this chapter is to establish minimum design specifications for selected technologies used as primary and auxiliary user input devices at computer workstations in office settings. The scope of this chapter pertains to design features of alphanumeric keyboards and selected non-keyboard devices as listed below.

- Keyboards
- Mouse and puck devices
- Trackballs
- Joysticks
- Stylus and light pens
- Tablets and overlays
- Touch-sensitive panels

The specifications presented in this chapter are intended to apply to devices used for producing, editing, and using text and graphics presented on the workstation visual displays during the user's work sessions. This chapter does not pertain to input device technologies omitted from the list above.

### 6.2 Design Specifications

#### 6.2.1 GENERAL SPECIFICATIONS

The following specifications apply to all input devices considered in this chapter and intended for an adult user population. Designers and manufacturers of specific input devices are referred to these general specifications and to the relevant specifications in Chapter 5, Installed Systems.

##### 6.2.1.1 Control Dynamics

The control dynamics, such as control/display ratio, of non-keyboard input devices **should**

- Be user adjustable, within appropriate limits and if applicable to the device
- Be compatible with users' expectations for direction, speed, and location of movement through appropriate user references and examples

*Control/display ratio (C/D ratio)* is the relationship between movements of an input device and the associated movements of a visual indicator on a display screen. A low C/D ratio indicates that small device movements move the visual indicator rapidly across screen distance, whereas a high C/D ratio indicates that large device movements result in slow or small visual indicator movements. A user-adjustable C/D ratio is advantageous for accommodating user proficiency and task demands that require varying degrees of rapid, gross-distance movements and accurate, fine positioning.

### 6.2.1.2 Device Stability

Input devices placed on a stable horizontal surface **should**

- Be stable (i.e., not wobble or stick) during normal operation

Likewise, integrated buttons and keys **should**

- Be stable (i.e., not wobble or stick) during normal operation

Activation of integrated buttons or keys **should not**

- Cause inadvertent movement of the input device (potentially leading to unintended inputs or errors)

Device instability (from slipping or rocking) and poor grip surfaces can adversely affect performance and lead to increased effort and errors. Smooth key and button action aids performance, reduces keying effort, and promotes user satisfaction. Button activation that requires users to alter their grip frequently can result in increased effort, unintentional cursor movement, and difficulty in simple object (target) acquisition (see Cushman & Rosenberg, 1991, Chapters 8 and 13).

### 6.2.1.3 Intentional Movements

Users should

- Be able to position input devices accurately and quickly without exerting excessive effort or force

However, the effort or force required to position the input device **should**

- Be sufficient to prevent the device from unintended drifting or changing of position

There must be a balance between the effort and force required for the user to position the device easily and the need for the device to remain stable at its intended position.

### 6.2.1.4 Grip Surface

The grip surfaces **should**

- Be sized, shaped, and textured to prevent slipping and unintended movements during normal operation

Input devices with buttons **should**

- Permit button activation without requiring alteration of the handgrip

### 6.2.1.5 Handedness

An input device designed for one-handed operation **should**

- Be operable with either hand

If the input device is designed for operation by a particular hand, then both left- and right-handed versions **should**

- Be available to users

### 6.2.1.6 Surface Reflectance

Specular reflectance (gloss) of input device surfaces that are visible during normal operation **should**

- Be 45% or less

Excessive reflectance of surfaces visible during normal operation can cause glare, which may lead to user discomfort and degraded visual performance (Sanders & McCormick, 1993, pp. 533–539).

### 6.2.1.7 Edges, Corners, and Surfaces

Hard surface edges and corners that come into contact with the user during normal operation **should**

- Have a radius of at least 2 mm (0.078 in.)

Radius is defined as the distance from the rounded surface to the center of the circle creating the arc. For surfaces that are not perfectly round or of constant radius, the minimum/smallest radius of the surface should be used. Flush-mounted features are excluded from this recommendation. Prolonged or frequent pressure and contact with sharp edges and corners can lead to discomfort, distraction, and degraded performance.

### 6.2.1.8 Button Placement

Thumb and finger-operated buttons on input devices **should**

- Be accessible during normal operation and

**should**

- Be activated with thumb/finger flexion, not extension

Hard-to-reach input device buttons or those that necessitate awkward or extreme thumb and/or finger motions can lead to fatigue and degraded performance.

### 6.2.1.9 Button Force and Displacement

For tasks involving frequent use of buttons on an input device, the maximum force needed to press and activate such buttons **should**

- Be between 0.25 and 1.5 N (0.9 ounce-force–5.4 ounce-force)

Button activation forces under 0.25 N (0.9 ounce-force) **should**

- Be avoided

Buttons **should**

- Have a displacement between 1.0 and 6.0 mm (0.04 in. to 0.24 in.)

Buttons **should**

- Support the resting weight of the thumb/finger in order to minimize accidental activation or the need to suspend the thumb or finger over the button in order to prevent accidental actuation

Although most research on the operation of small push buttons is associated with keying, typing, and keyboards, it is reasonable to generalize from this research to the use of push buttons on other input

devices, especially when tasks involve frequent push-button operation. Consequently, this specification is supported by the literature and general consensus regarding minimum and maximum key-activation forces.

#### **6.2.1.10 Button Feedback**

Input device buttons **should**

- Provide feedback to users upon activation

Tactile or auditory feedback modes, or combinations of these feedback modes, are acceptable.

If auditory feedback is provided through software, it **should**

- Be user suppressible

A consistent research finding involving keying and push-button use is that feedback is essential during the acquisition of keying skill. Feedback aids in facilitating learning. Tactile feedback is suggested for high-volume or high-frequency button use and keying. Auditory and/or visual feedback as well as tactile feedback can be helpful during training (Cushman & Rosenberg, 1991).

#### **6.2.1.11 Button Lock**

A locking feature **should**

- Be provided for buttons on input devices that are used for tasks involving prolonged or continuous button depression

The button-lock feature is intended to relieve or reduce the necessity for continuous pressure by the finger to activate a button during specific task operations. This specification can be met through hardware or software controls.

#### **6.2.1.12 Labels**

Labels on input device controls **should**

- Be visually distinguishable and interpretable to users

Text-based labels **should**

- Be printed in a sans-serif font and in title case (i.e., uppercase first letter and remaining letters in lowercase)

Buttons, keys, and controls with full or partial function labels often lead to better performance than do unlabeled ones. Effective ways to label and group functions include borders, colors, fonts, labels, shape, size, shading, and spatial separation. If text labels are not feasible (e.g., because of space constraints), graphic symbols may be employed.

### **6.2.2 KEYBOARDS**

Keyboard rows are described by the codes “A,” “B,” “C,” “D,” and “E” (see Figure 6-1).

Row A is closest to the user; Row C is the center or home row. Some keyboards do not have a Row E. Additional rows of keys follow this same naming convention, for example, an additional row would be labeled as Row F, and so forth.

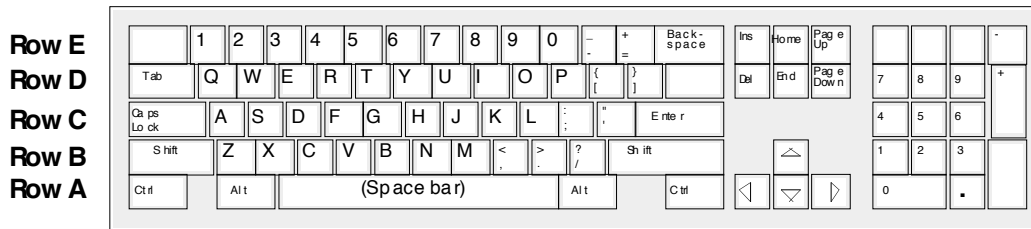

Figure 6-1. Row references for conventional keyboards.

## 6.2.2.1 Keyboard Layout

### 6.2.2.1.1 *Alphabetic Keys*

The alphabetic keys **should**

- Be grouped in the primary keying area

and function keys (the first row of keys beyond the alphanumeric portion of the keyboards) **should**

- Be located next to the primary keying area

Key grouping as shown in Figure 6-1 aids the logical organization of keyboards and facilitates the standardization of key layouts (Sanders & McCormick, 1993, p. 457). Standardization of key layouts is important and beneficial for users who need to transfer among computer workstations. Widely different layouts often involve a negative transfer of learning that can affect performance. In this regard, the QWERTY keyboard layout has been accepted as the de facto industry layout. QWERTY is the sequence of the letters on the left hand side of the top row of alphabetic keys. However, research exists that supports the acceptability of other keyboard layouts (e.g., the Dvorak keyboard) for general text-entry tasks (Alden, Daniels, & Kanarick, 1972).

### 6.2.2.1.2 *Numeric Keypads*

In the design and manufacture of keyboards, numeric keypads **shall**

- Be provided when users' primary task involves numeric data entry

These keys **shall**

- Be grouped together

and, if integrated with the keyboard, **should**

- Be located to the side of the primary keying area

Either of the two numeric keypad layouts in Figure 6-2 is recommended. Keys with similar functions **should**

- Be grouped together

Usability studies on the layout of numeric keypads have supported both the telephone and calculator layouts (Conrad & Hull, 1968; Deininger, 1960; Lutz & Chapanis, 1955; Seibel, 1972).

The location of the keypad on the right-hand side of the primary keying area is conventional industry practice, although this location does not best accommodate left-handed users. Because key positions

for the zero, double zero, triple zero, comma, decimal, and other such keys may be application dependent, alternative locations for such keys may influence performance.

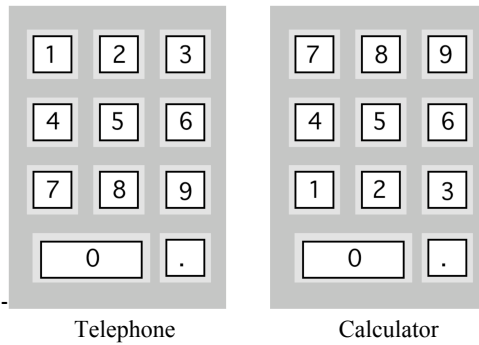

**Figure 6-2. Numeric keypad layouts**

### 6.2.2.2 Cursor Control

A two-dimensional cursor control (e.g., cursor keys, mouse, trackball) **shall**

- Be provided for text- and graphics-processing tasks

If cursor keys are provided, they **shall**

- Be arranged in a two-dimensional layout (four examples of possible layouts are illustrated in Figure 6-3) and

they should

- Be dedicated to cursor movement

If the cursor keys have collateral functions, their operational mode status **shall**

- Be clearly indicated

Additional keys placed near the cursor controls are acceptable provided that the overall layout of the cursor control keys is unchanged. There are two main patterns, the “Cross” and the ‘Inverted T.’ Each has two variants that differ only by their location in the keyboard rows, as shown in Figure 6.3.

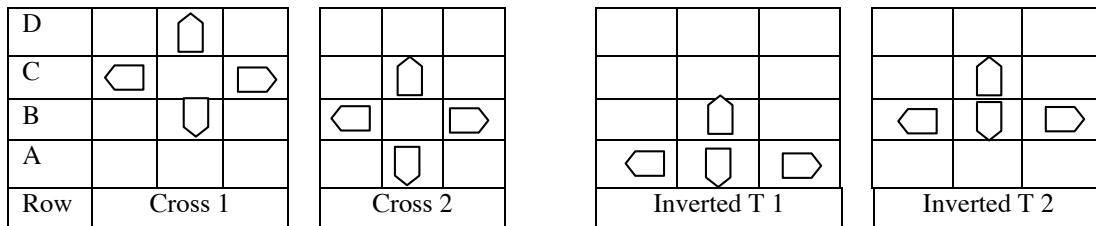

**Figure 6-3. Cursor key layouts.**

The usability of cursor keys is influenced by users’ expectations for spatial and/or positional compatibility with the direction of cursor movements. Emmons (1984) showed that the performance of inexperienced (novice) users was greater with a cross arrangement than with a box format. Reger,

Snyder, and Epps (1987) showed that the inverted T was the most preferred of six common arrangements and that no significant performance or preference differences existed between the inverted-T and cross cursor control arrangements.

Editing keys (Insert, Delete, Home, End, PageUP, PageDown) **should**

- Be provided for keyboard navigation, control and editing purposes

These keys **should**

- Be arranged in a functional group

### 6.2.2.3 Keyboard Height, Slope, and Wrist/Palm Support

Keyboards, in combination with their supporting surface, chair, and other furniture, **shall**

- Permit users to attain the postural design criteria in the selected reference posture stated in Section 5.2.1.1, User Postures

The goal with keyboard height and slope designs/adjustments is to promote neutral postures in the wrist and forearm when using the device (see sections 5.2.1.1 and 5.3.1). Figures 6-4 and 6-5 illustrate keyboard tilt and keyboard height, respectively.

Consistent with these postural design criteria, the slope of conventional desktop keyboards (rectangular keyboards with an alphanumeric and numeric keypad area and on which the home row of keys forms a straight line) **shall**

- Provide at least one positive slope setting between 0 and 15 degrees



**Figure 6-4. Illustration of keyboard slope. The slope is positive when the A row is lower than the D or E row, and negative when the A row is higher than the D or E row. After ISO 9241, part 4 (ISO, 1998).**

For contemporary or alternative keyboard designs that attempt to minimize the deviation of the hand and/or wrist from a neutral posture, the keyboard slope may extend beyond the stated positive slope range as well as include negative slopes in order to promote neutral wrist postures. The goal is to promote a neutral posture in both the flexion/extension and radial /ulnar planes and with regard to rotation of the forearm (pronation /supination). The American Academy of Orthopedic surgeons defines neutral flexion/extension as the position where the horizontal plane created by the back of the hand is even and parallel with the horizontal plane created by the back of the forearm.

Keyboard height and slope are interrelated (see Section 5.2.3.4, Input Device Location). Whereas slope adjustments up to 15 degrees have been incorporated into conventional keyboard designs, research has

shown user preferences for even greater slopes (Burke, Muto, & Gutmann, 1984; Emmons & Hirsch, 1982; Miller & Suther, 1981).

Some keyboard designs, as illustrated in Figure 6-6, may use height, articulation, and tilt advantageously to aid in promoting neutral wrist posture (Hedge and Powers, 1995; Simoneau and Marklin, 2001)

If a height and/or slope adjustment mechanism is provided, there **shall**

- Be at least one adjustment that allows the keyboard to conform to the height specification

The preferred keyboard height is 30 mm or less and **should**

- Not exceed 35 mm (1.37 in.)

Keyboard height is the height measured from the table surface to the middle of the home row of the keyboard.

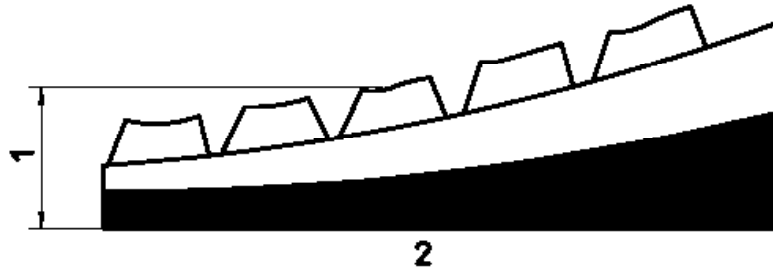

Figure 6-5. Keyboard height measured from table surface to middle of home row of keyboard. From ISO 9241, part 4 (ISO, 1998).

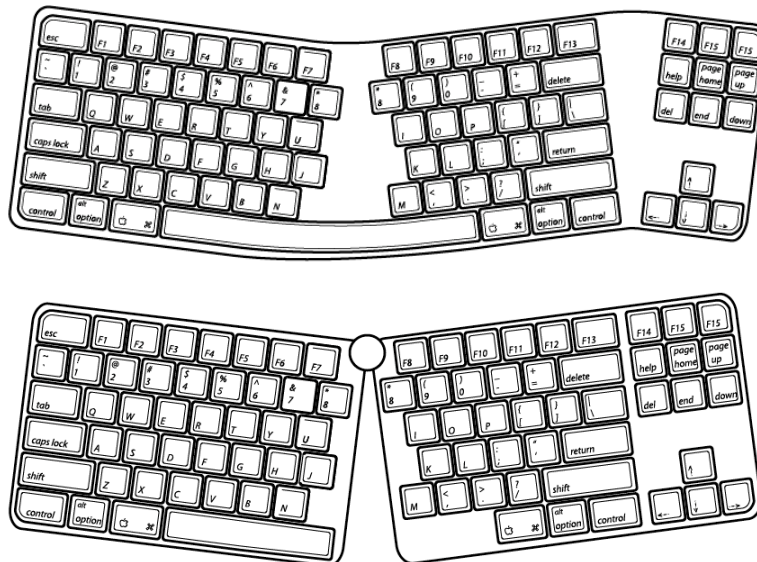

Figure 6-6. Keyboard slant (split) and tilt (gable). From Marklin, Simoneau, and Monroe (1999).



#### 6.2.2.4 Profile

The keyboard rows **should**

- Be arranged in a dished (concave), stepped, sloped, or flat profile

Various keyboard profiles are considered acceptable (Cakir, Hart, & Stewart, 1980, pp. 125–126). Research examining stepped and sloped keyboard profiles found no notable differences in user performance (Kinkead & Gonzales, 1969). Other keyboard profiles may be possible, however they have not been studied with regard to acceptability.

#### 6.2.2.5 Dual-State Keys

Dual-state (toggle) keys **should**

- Indicate their operational (functional) status

Dual-state keys include keys such as Caps Lock, Num Lock, Scroll Lock, and Function Lock. A common problem with dual-state keys or push buttons is visual identification of the position or state of the key. An effective solution is to provide a separate indicator light (see Cushman & Rosenberg, 1991, Chapter 8). Therefore, the preferred method for the status of dual-state keys is an indicator light.

When indicator lights are employed, they **should**

- Be imbedded in the key, located close to the associated keys or
- Be clearly labeled if not located close to the keys (e.g., Caps Lock icon)

An indicator panel for one or more dual-state keys is acceptable. Other means for indicating the status of dual-state keys may be effectively used such as showing the functional status on the receiver of a wireless keyboard or on the primary/main display.

#### 6.6.2.6 Key Nomenclature

Nomenclature for the primary symbols on the alphabetic (i.e., A through Z) keys of the keyboard **should**

- Be a minimum of 2.6 mm (0.10 inch) in height

and **should**

- Have a minimum luminance modulation of 0.5 Lux

Contrast ratio between legend and key background **should**

- Be 3:1

Key nomenclature may be darker or lighter than the background.

The key nomenclature height recommendation is based on text- and display-related legibility research. Legibility is the rapid identification of single characters that may be presented in a non-contextual format. The threshold height for comfortable reading during a legibility task is in the range of 16 to 18 minutes of visual arc (0.267 deg. to 0.3 deg). A character height of 2.6 mm viewed from a distance of 560 mm would yield a symbol size of 16 minutes of visual arc.

### 6.2.2.7 Key Spacing

The centerline-to-centerline horizontal and vertical spacing between adjacent keys within the alphanumeric and numeric zones **shall**

- Be 19 mm +/- 1 mm (0.74 in. +/- 0.039 in.)

Function keys and infrequently used keys may be smaller. The specification for horizontal and vertical key spacing is supported by conventional practice. The key-spacing specifications apply to keys within a functional group but not to the separation between functional groups of keys, such as noncontiguous keys in a conventional or alternative keyboard design.

As shown in Figure 6-7, key spacing is the distance between corresponding points on two adjacent keys, measured horizontally ( $S_h$ ) and vertically ( $S_v$ ).

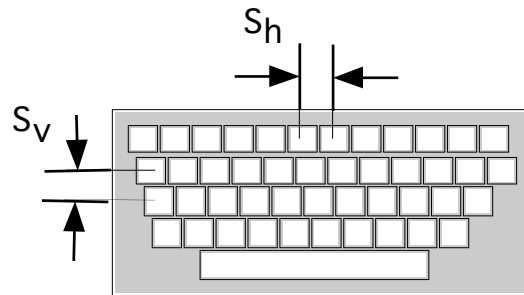

Figure 6-7. Illustration of key spacing.

### 6.2.2.8 Key Size and Shape

For alphabetic keys in the alphabetic key area, the horizontal strike surface **should**

- Be at least 12 mm (0.47 in.) wide

and the contact surface **should**

- Be concave to match the geometry of the tip of the finger and enhance coupling during the strike

Rectangular (square) strike surfaces on keys provide larger target areas than do circular strike surfaces for a given key spacing. Also, concave keys provide a good fit to fingertips (Cakir et al., 1980; Clare, 1976).

### 6.2.2.9 KeyForce

The force to activate the main alphabetic keys at the (tactile peak) snap point **shall**

- Be between 0.25 and 1.5 N (0.9 ounces force–5.4 ounces force)

The preferred key force at the snap point **should**

- Be between 0.5 and 0.6 N (1.8 ounces force–2.2 ounces force)

Variability of key-activation force among these keys **should**

- Be minimized

The key-force specification is based on research of various types of keyboards, as well as of conventional industry practice over the past three decades (Cakir et al., 1980, pp. 128–129; Seibel, 1972, pp. 337–338). Computer keyboards typically use key-activation forces from 0.4 to 1.2 N (Greenstein & Arnaut, 1987, p. 1461), with most keyboards requiring forces below 1.0 N. Consensus on key-activation forces indicates that users prefer forces from 0.4 to 0.8 N (Grandjean, 1987, p. 1391).

However, more recently it has been found that users tend to press keys with more force than required (Armstrong, Foulke, Martin, Gerson, & Rempel, 1994; Gerard 2002). Thus, to limit key-activation forces below 0.8 N, the preferred range of 0.5 to 0.6 N at the snap point is recommended (Kinkead & Gonzales, 1969).

Key-activation force is assessed from a force-displacement curve (Figure 6-8) and is defined as the maximum force immediately prior to the switch closure or “make” point of the key along the force displacement curve.

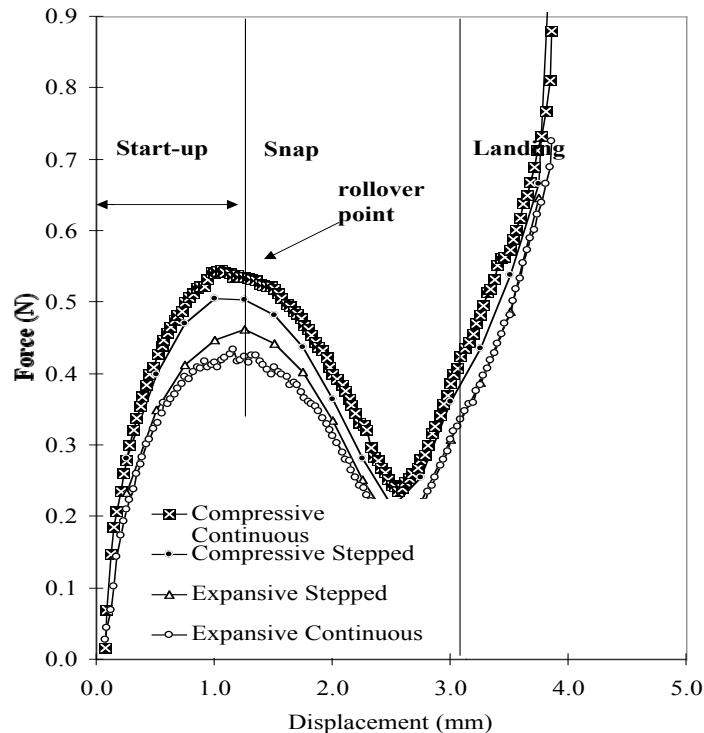

Figure 6-8. Example of force displacement curves.

Static measurements should be made at the center of the keys and at the corners. When measured at the corners there should be minimal binding (actuating force increase) at these locations.

### 6.2.2.10 Key Displacement

Vertical displacements of the alphabetic keys **shall**

- Be between 1.5 and 6.0 mm (0.06 in. to 0.24 in.)

The vertical displacements of these keys **should**

- Be between 2.0 and 4.0 mm (0.08 in. and 0.16 in.)

Variability of vertical displacements among keys **should**

- Be minimized

For infrequently used keys outside the alphanumeric numeric and editing zones, key vertical displacements can be less than 2 mm. Research on key displacements indicates that range has little effect on user performance. Key displacements between 2.0 and 4.0 mm tend to produce the highest text- and data-entry rates with the fewest errors. However, smaller displacements, of between 0.7 and 1.6 mm, have been found to be acceptable under some circumstances, such as when entry is not continuous (Kinkead & Gonzales, 1969).

#### **6.2.2.11 Key Rollover/Simultaneous Key Depression**

*Key rollover* refers to the number of characters produced by simultaneous activation of keys. Keyboards **should**

- Have at least three-key rollover. An  $n$ -key rollover is recommended

Two-key rollover permits a second key to be depressed while one key is already down but will not produce a character until the first key is released. If the second key is released before the first key, the second key will be missed. If two keys are pressed simultaneously, all output is blocked. Three-key rollover will produce two characters accurately for two simultaneously depressed keys. Depression of a third key does not produce a character until one of the first two keys is released. In contrast,  $n$ -key rollover will produce any number of characters accurately no matter how many keystrokes overlap (Greenstein & Muto, 1988).  $N$ -key rollover is preferred to two-key and three-key rollover schemes (Davis, 1973; Gladman, 1976; Kallage, 1972).

#### **6.2.2.12 Keying Feedback**

Actuation of any key **shall**

- Be accompanied by tactile or auditory feedback, or both

If auditory feedback is provided, the sound **should**

- Occur at the same point in the displacement for all keys

If the auditory feedback is provided through software, the user **should**

- Be able to adjust the volume and turn it off

If tactile feedback is provided, the point of key activation (switch closure or make point) **should**

- Be marked by a distinguishable breakaway force

Tactile feedback for the key activation (snap point) can be implemented by increasing key force throughout the initial 40% of key displacement, then reducing key force over the next 20% of total displacement where the switch closure occurs, and again increasing key force over the remaining key displacement range.

Feedback is essential during the acquisition of keying skills; however, detailed specifications are difficult to establish because feedback effectiveness depends on feedback mode, user keying skill, task demands, and keyboard layout. Elimination of the breakaway force or the subsequent cushioning force

can result in slower keying activity, higher error rates, and increased operator fatigue (see Cushman & Rosenberg, 1991, Chapter 8; Kinkead & Gonzales, 1969; Klemmer, 1971).

### 6.2.2.13 Key Repeat Rate

The default character repeat rate **should**

- Be approximately 10 characters per second after an initial delay of 500 ms following key activation

The character repeat rate **should**

- Be user adjustable

Key repeat allows the user to enter a character or command multiple times without needing to repeat keystrokes. Most conventional keyboards implement the key repeat function on all keys. The keyboard repeat rate may either be implemented in the hardware or software.

### 6.2.2.14 Home Row Locator

The home row keys (Row “C” as in Figure 6-1) **should**

- Contain at least one tactile feature to assist users in positioning their fingers on the keyboard

Current industry practice is to use a small raised bar, a dimple, or some other shape on the key cap. A tactile indicator on the home row keys, typically the *F* and *J* keys in the alphanumeric area and 5 on the numeric keypad, provides a reference landmark for users to orient their hands and fingers over the home row and the keyboard (Gladman, 1976, p. 149). A tactile indicator on the “5” key in the numeric keypad can also be used as a reference landmark for users to orient their hands and fingers over the numeric keypad.

### 6.2.2.15 Keyboard Wrist Rest

The intent of wrist rest is to promote more neutral postures in the wrist. For keyboards with integrated or attachable wrist rests/palm supports for the proximal portion of the palm, the rest or supports **should**

- Be matched to the width, height, and shape of the front edge and slope of the keyboard

Matching the width, height, and shape of the rest or supports to the front edge of the keyboard provides a smooth transition from the surface of the rest or support surface to that of the keyboard. Sharp corners and/or small radius edges that create pressure points should be avoided. Differences in width, height, and shape between the rest or support and the keyboard may be cumbersome, constrain the user, or limit access to the keyboard. Some users prefer to use wrist rests with keyboards. However, some rests may inhibit motion of the wrist during typing. Thus, a wrist rest is considered an optional feature.

## 6.2.3 MOUSE DEVICES

A *mouse* (Figure 6-9) is a hand-operated input device typically used for two-dimensional cursor-positioning and object-selecting tasks. The mouse often resembles a palm-sized, contoured block with one or more thumb- and/or finger-operated buttons. The mouse is moved over a surface in order to move a cursor on the screen. Refer to sections 6.2.1.4–6.2.1.8 for general design considerations.

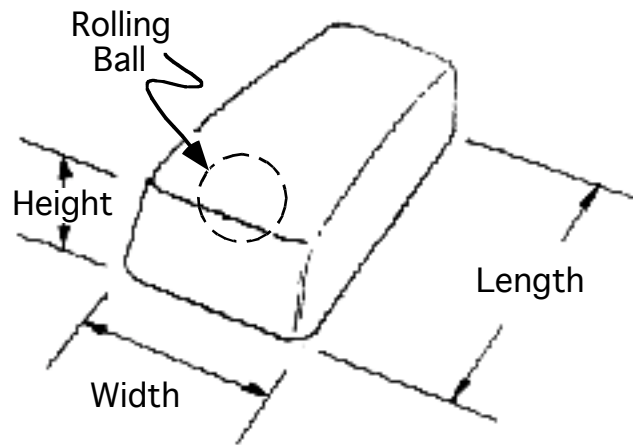

**Figure 6-9. Illustration of a mouse. Note. Many mice use an optical motion sensor rather than a ball.**

### 6.2.3.1 Shape and Size

The shape and size of a mouse **shall**

- Allow single-handed operation

Users can comfortably grip rectangular-shaped mice that are between 40 and 70 mm wide, between 70 and 120 mm long, and between 25 and 40 mm high (Goy, 1988; U.S. Department of Defense, 1989). Overly form-fitting mouse designs should be avoided because they can result in continual and prolonged contact between the device and the skin's surface, reducing the ability of the skin to breathe and resulting in hand perspiration. Overly form-fitting mouse designs offered in just one size rarely work well for a wide variety of hand sizes.

### 6.2.3.2 Motion Sensor

The motion sensor **should**

- Be located toward the front of the input device, under the fingertips, not the palm

This specification is intended to facilitate fine-positioning accuracy with the device through greater sensitivity in fingertip-driven and/or wrist-based movements. Locating the rolling ball or motion sensor underneath the fingertips increases the apparent moment of inertia as the device is pivoted from the elbow or the heel of the hand (Verplank & Oliver, 1989). This assists hand movements involved in fine positioning because the forward location conveys the motion of the hand more accurately. The design of mice that use a mechanical ball and encoder system to sense movement should facilitate easy removal and cleaning of the ball and encoder. The ball and encoder should be made of materials that do not easily attract and accumulate dust and/or dirt.

## 6.2.4 PUCK DEVICES

A puck (Figure 6-10) is similar in shape to a mouse but typically is used in conjunction with a digitizing surface (e.g., tablet) for encoding graphics in drawing tasks and for selecting objects. A puck typically consists of a reticule window that allows users to align the device accurately. Refer to sections 6.2.1.4–6.2.1.8 for general design considerations.

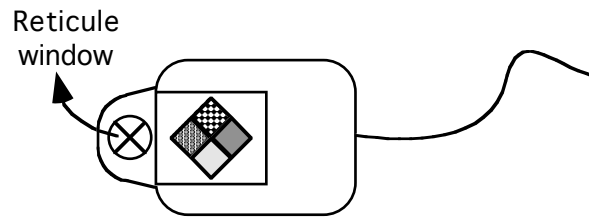

**Figure 6-10. Illustration of a puck.**

### 6.2.4.1 Shape and Size

The shape and size of a puck **shall**

- Allow single-handed operation

Users can comfortably grip rectangular-shaped puck devices that are between 40 and 70 mm wide, between 70 and 120 mm long, and between 25 and 40 mm high (Goy, 1988; U.S. Department of Defense, 1989).

### 6.2.5 TRACKBALLS

A trackball (Figure 6-11) is a hand-operated or finger-operated input device that is used typically for cursor movement and object selection tasks. Trackballs generally are mounted into a horizontal surface (desk or keyboard) or are built into their own module. These devices can include finger-operated and thumb-operated buttons located near the ball. Users' rotations of the trackball cause movements of the cursor on the screen. Trackballs can be rotated in any direction to generate any combination of x and y control.

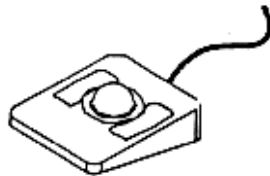

**Figure 6-11. Illustration of a trackball.**

#### 6.2.5.1 Diameter

As shown in Figure 6-12, the diameter of a desktop-mounted trackball **should**

- Be between 50 and 150 mm (1.97 in. and 5.9 in.)

The exposed surface of the trackball **should**

- Be between 100 and 140 degrees

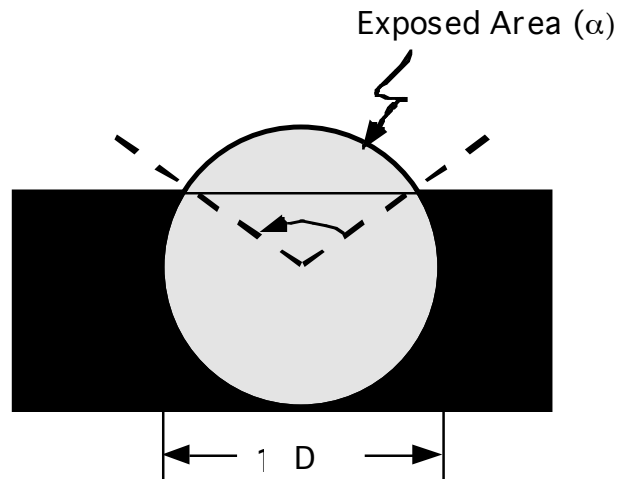

**Figure 6-12. Exposed surface and diameter of trackball.**

This specification is based on conventional practice (U.S. Department of Defense, 1989). Task-related factors to consider when selecting an appropriate trackball include type(s) of motions and cursor movements, level of precision required, and space constraints.

### 6.2.5.2 Resistance

Resistance **should**

- Be less than 1.0 N (0.22 pounds force) and preferably less than 0.3 N (0.66 pounds force)

This specification is based on conventional practice (U.S. Department of Defense, 1989). It is intended to enable users to apply a minimum amount of force to move the trackball accurately. Some amount of resistance is necessary to dampen the ball.

### 6.2.6 JOYSTICKS

A *joystick* (Figure 6-13) is a finger- or hand-operated device used for two-dimensional tracking tasks and complex perceptual/motor tasks. It also may be used for pointing and selection tasks, if precision is not critical. Joysticks consist of a handle for the main control interface, and these devices may contain one or more buttons on the handle top or device housing (Arnaut & Greenstein, 1988, p. 101; Cushman & Rosenburg, 1991, p. 196).

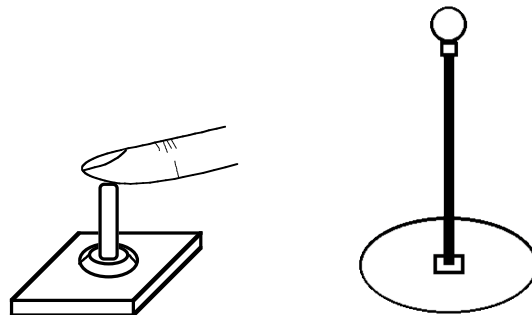

**Figure 6-13. Finger-operated (left) and hand-operated (right) joysticks.**



### 6.2.6.1 Handle Size

The handle of a finger-operated joystick **should**

- Be between 6.5 and 16.0 mm (0.26 and 0.63 in.) in diameter and
- Be between 25 and 150 mm (0.98 and 5.9 in.) long

The grip surface of a hand-operated joystick **should**

- Be less than 50 mm (1.97 in.) in diameter and
- Be 110 to 180 mm (4.3 to 7.1 in.) long

The handle size specifications are based on basic anthropometric considerations and conventional practice (Arnaut & Greenstein, 1988; U.S. Department of Defense, 1989).

### 6.2.6.2 Force

The force to displace the cursor with a hand- or finger-operated joystick **should**

- Be at least 4.5 N (1.01 pound force)

A force joystick (isometric) responds to pressure on the joystick to move the cursor or visual indicator. For joysticks with a handle diameter of between 9 and 10 mm, a full-scale force of approximately 9.0 to 15.0 N tends to work best for graphics tasks. A minimum force of 4.5 N is recommended (Doran, 1989).

### 6.2.6.3 Displacement

For displacement (isotonic) joysticks, the angular displacement from the rest position **should not**

- Exceed 45 degrees

The angular displacement specification is based on conventional practice (U.S. Department of Defense, 1989). Angular displacements beyond 45 degrees require a greater range of motion and involve more demanding hand and wrist postures.

## 6.2.7 STYLI AND LIGHT PENS

Styli and light pens are handheld input devices used for object selection, cursor movement, and freehand drawing tasks. They have a pencil-like shape and contain one or more finger-operated buttons. Typically, styli are used with tabletop digitizing surfaces (e.g., pressure-sensitive tables), whereas light pens are used with Cathode Ray Tube (CRT) display devices. [AQ: no Fig 6-14 callout]

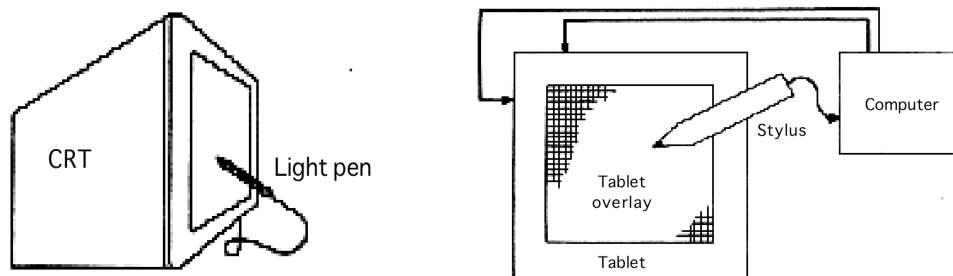

Figure 6-14. Illustrations of light pen and stylus.

### 6.2.7.1 Surface

The exterior surface of the pen or stylus **should not**

- Allow the pen or stylus to slip from the user's hand

The exterior grip surface of a stylus or light pen is a key design component in the stability and effort involved during its use. A stylus that is comfortable to hold and easy to grip will aid in an operator's effectiveness.

### 6.2.7.2 Button Shape

Barrel-mounted buttons on a stylus or light pen **should**

- Be shaped for comfort and not cause excessive pressure points

Barrel-mounted buttons or switches on a stylus or light pen are typically used to make selections or provide additional functionality. Button or switch designs that have sharp edges or corners or create an excessive pressure point can rapidly lead to discomfort or distraction and can potentially degrade performance.

### 6.2.7.3 Diameter

The diameter of a stylus or a light pen **should**

- Be between 7.0 and 20.0 mm (0.28 and 0.79 in.)

The barrel size of the stylus or light pen can affect the operator's comfort, grip, and overall effectiveness. This specification is based on conventional practice and is intended to enable the user to comfortably grip the barrel of the stylus or light pen (U.S. Department of Defense, 1989).

### 6.2.7.4 Length

The length of a stylus or light pen **should**

- Be between 120 and 180 mm (4.7 and 7.1 in.)

The length and balance of a stylus or light pen can affect the operator's effectiveness. This specification is based on basic anthropometric considerations and conventional practice. It is intended to provide users with an adequate stylus or pen length to improve overall effectiveness (U.S. Department of Defense, 1989).

## 6.2.8 TABLETS AND OVERLAYS

*Tablets* are flat, slate-like panels that can be used for cursor movement and object selection tasks. Typically, a tablet is configured with a puck or stylus to provide the user with an electronic digitizing surface. Many tablet systems consist of opaque overlays, which provide graphics used for the cursor movement and for button activation.

### 6.2.8.1 Surface

The active area of a tablet or touch-sensitive surface **should**

- Be flat, smooth, and free from warping or surface imperfections

Uneven surfaces and surface abnormalities can create an unstable work situation, interfering with a puck, a stylus, and the user's finger. Such conditions can lead to an increase in errors, effort, and fatigue.

### **6.2.8.2 Attachment and Detachment**

Users should

- Be able to attach and remove the overlay easily from the tablet

However, the overlay **should not**

- Detach unintentionally from the tablet during usage periods

Overlays that are difficult to attach or detach from the tablet can interrupt the flow of work and reduce productivity. Likewise, loosely attached overlays that slip or become detached can disrupt user performance.

### **6.2.9 TOUCH-SENSITIVE PANELS**

Touch-sensitive panels are finger-operated devices used primarily for object- and button-selection tasks; however, they can also be used for cursor movement and drawing tasks. A touch-sensitive panel consists of an overlay or empty frame mounted over the visual display screen. In typical applications, users press a finger or pointing device on the screen to signal a location to the computer. Users also may drag their finger or pointing device on the screen for object movement and drawing tasks.

#### **6.2.9.1 Minimum Touch Area**

Touch areas (soft keys) **should**

- Be at least 9.5 mm (0.4 in.) wide and 9.5 mm (0.4 in.) high

If the touch screen and the image plane of the screen are separated, the dimensions of the touch areas **should**

- Be increased to avoid user performance degradation attributable to parallax problems

The optimum touch-sensitive area depends on the application and required accuracy. Touch areas greater than 22 mm square do not improve performance (Beaton & Weiman, 1984; Beringer & Peterson, 1985; Weisner, 1988).

#### **6.2.9.2 Dead Space**

The dead space surrounding each touch area **should**

- Be at least 3.2 mm (0.13 in.)

Dead spaces (Figure 6-15) minimize accidental activation of keys, especially when parallax is present or when touch areas are small (Beringer & Peterson, 1985; Martin, 1988; Usher & Ilett, 1986). Smaller dimensions for the dead space can be used when error-preventing algorithms are used to encode the touch-area activations.

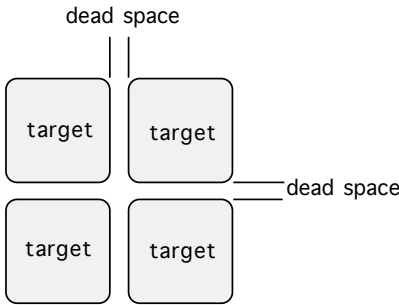

**Figure 6-15. Touch panel dead space.**

### 6.2.9.3 Target Tracking

During a select-and-drag operation, the object or cursor being moved **should**

- Track the finger, both temporally and spatially

Real-time tracking provides the user with direct feedback on target status and position.

## 6.3 Metrics

### 6.3.1 DEVICE STABILITY

Observe the input device during normal, expected use. Determine whether or not it slips or rocks during use. The input device should be installed as per design instructions.

To assess the stability of input device keys, observe the input device in normal, expected use. Determine whether or not the keys wobble or stick.

### 6.3.2 NUMERIC KEYPAD LAYOUT

Determine if a numeric keypad is provided as appropriate for users. Verify that the keys on the numeric keypad are arranged in one of the patterns shown in Figure 6-2.

### 6.3.3 CURSOR CONTROL

Determine whether a two-dimensional cursor control is provided for users, as is appropriate. If cursor control keys are provided, verify that the keys are arranged in one of the two patterns shown in Figure 6-3.

### 6.3.4 KEYBOARD HEIGHT AND SLOPE

Verify that the keyboard, when installed as directed, does not cause the user to violate the postural guidelines described in Section 5.2.1.1. Verify that the slope of the keyboard is between 0 and 15 degrees. The slope of the keyboard is determined by the angle between the plane of the support surface and the plane passing through the centers of the keys, or other equivalent and corresponding points of keys, in the rows containing Q and Z in the QWERTY layout.

### 6.3.5 KEY SPACING

Vertical and horizontal key spacing is measured from key centers as shown in Figure 6.7.

### 6.3.6 KEY FORCE

*Key force* is the maximum force necessary to the “snap” point measured in the geometric center of the key top strike area along the same axis as the key travel. [AQ: Please clarify meaning.]

### 6.3.7 KEY DISPLACEMENT

Key displacement is measured in the axis of the key travel.

### 6.3.8 KEYING FEEDBACK

Verify by observation that key actuation is accompanied by either tactile or auditory feedback.

### 6.3.9 SHAPE AND SIZE

Verify by observation that the mouse or puck can be operated with one hand.

## 6.4 References

- Alden, D. G., Daniels, R., & Kanarick, A. F. (1972). Keyboard design and operation: A review of the major issues. *Human Factors*, *14*, 275–293.
- Armstrong, T. J., Foulke, J. A., Martin, B. J., Gerson, J., & Rempel, D. M. (1994). Investigation of applied forces in alphanumeric keyboard work. *American Industrial Hygiene Association Journal*, *55*, 30–35.
- Arnaut, L. Y., & Greenstein, J. S. (1988). Human factors considerations in the design and selection of computer input devices. In S. Sherr (Ed.), *Input devices* (pp. 71–122). San Diego, CA: Academic.
- Beaton, R. J., & Weiman, N. (1984). *Effects of touch key size and separation on menu-selection accuracy* (Tech. Report TR 500-01). Beaverton, OR: Tektronix, Human Factors Research Laboratory.
- Beringer, D. B., & Peterson, J. G. (1985). Underlying behavior parameters of the operation of touch-input devices: Biases, models, and feedback. *Human Factors*, *27*, 445–458.
- Burke, T. M., Muto, W. H., & Gutmann, J. C. (1984). Effects of keyboard height on typist performance and preference. In *Proceedings of the Human Factors Society 28th Annual Meeting* (pp. 272–276). Santa Monica, CA: Human Factors and Ergonomics Society.
- Cakir, A., Hart, D. J., & Stewart, T. F. M. (1980). *Visual display terminals*. New York: Wiley.
- Clare, C. R. (1976). Human factors: A most important ingredient in keyboard designs. *EDN*, *21*(8), 99–102.
- Conrad, R., & Hull, A. J. (1968). The preferred layout for numerical data-entry keysets. *Ergonomics*, *11*, 165–173.
- Cushman, W. H., & Rosenberg, D. J. (1991). *Human factors in product design*. New York: Elsevier.
- Davis, S. (1973, March). Keyswitch and keyboard selection for computer peripherals. *Computer Design*, pp. 67–79.
- Deininger, R. L. (1960). Human factors engineering studies of the design and use of pushbutton telephone sets. *Bell Systems Technical Journal*, *39*, 995–1012.
- Doran, D. (1989). Trackballs and joysticks. In S. Sherr (Ed.), *Input devices* (pp. 251–270). San Diego: Academic.
- Emmons, W. H. (1984). A comparison of cursor-key arrangements (box versus cross) for VDUs. In E. Grandjean (Ed.), *Ergonomics and health in modern offices* (pp. 214–219). Philadelphia: Taylor & Francis.
- Emmons, W. H., & Hirsch, R. S. (1982). Thirty millimeter keyboards: How good are they? In *Proceedings of the Human Factors Society 26th Annual Meeting* (pp. 425–429). Santa Monica, CA: Human Factors and Ergonomics Society.
- Gladman, R. (1976). Human factors in the design of visual display units. In D. Grover (Ed.), *Visual display units and their application* (pp. 137–152). Guilford, Surrey, UK: IPC Science and Technology.
- Goy, C. (1988). Mice. In S. Sherr (Ed.), *Input devices* (pp. 219–250). San Diego: Academic.
- Grandjean, E. (1987). Design of VDT workstations. In G. Salvendy (Ed.), *Handbook of human factors* (pp. 1359–1397). New York: Wiley-Interscience.
- Greenstein, J. S., & Arnaut, L. Y. (1987). Human factors aspects of manual computer input devices. In G. Salvendy (Ed.), *Handbook of human factors* (pp. 1450–1489). New York: Wiley-Interscience.
- Greenstein, J. S., & Muto, W. H. (1988). Keyboards. In S. Sherr (Ed.), *Input devices* (pp. 123–178). San Diego: Academic.

- Hedge, A., & Powers, J. A. (1995). Wrist postures while keyboarding: Effects of a negative slope keyboard system and full motion forearm supports. *Ergonomics*, 38, 508–517.
- International Organization for Standardization (ISO). (1998). *ISO 9241-4: Ergonomic requirements for office work with visual display terminals (VDTs)—Part 4: Keyboard Requirements*. Geneva: Author.
- Kallage, R. (1972, February). Electronic keyboard design with n-key rollover. *Computer Design*, pp. 57–61.
- Kinkead, R. D., & Gonzales, B. K. (1969). *Human factors design recommendations for touch-operated keyboards* (Document 12091-FR). Minneapolis, MN: Honeywell.
- Klemmer, E. T. (1971). Keyboard entry. *Applied Ergonomics*, 2, 2–6.
- Lutz, M. C., & Chapanis, A. (1955). Expected locations of digits and letters on ten-button keysets. *Journal of Applied Psychology*, 39, 314–317.
- Marklin, R. W., Simoneau, G. G., & Monroe, J. F. (1999). Wrist and forearm posture from typing on split and vertically inclined computer keyboards. *Human Factors*, 41, 559–569.
- Martin, G. L. (1988). Configuring a numeric keypad for a touch screen. *Ergonomics*, 31, 945–953.
- Miller, I., & Suther, T. W. (1981). Preferred height and angle settings of CRT and keyboard for a display station input task. In *Proceedings of the Human Factors Society 25th Annual Meeting* (pp. 492–496). Santa Monica, CA: Human Factors and Ergonomics Society.
- Reger, J. J., Snyder, H. L., & Epps, B. W. (1987). Performance and preference for cursor-key control configurations in editing tasks. *Society for Information Display Digest*, 22–25.
- Sanders, M. S., & McCormick, E. J. (1993). *Human factors in engineering and design*. New York: Wiley.
- Seibel, R. (1972). Data entry devices and procedures. In H. P. Van Cott & R. G. Kinkade (Eds.), *Human engineering guide to equipment design*. Washington, DC: U.S. Government Printing Office.
- Simoneau, G. G., & Marklin, R. W. (2001). Effect of computer keyboard slope and height on wrist extension angle. *Human Factors*, 43, 287–298.
- U.S. Department of Defense. (1989). *Human engineering design criteria for military systems, equipment and facilities*. Washington, DC: Author
- Usher, D. M., & Ilett, C. (1986). Touch-screen techniques: Performance and application in power station control displays. *Displays*, 7, 59–67.
- Verplank, W., & Oliver, K. (1989). Microsoft mouse: Testing for redesign. In *Proceedings of Interface '89* (pp. 257–261). Santa Monica, CA: Human Factors and Ergonomics Society.
- Weisner, S. J. (1988). A touch-only user interface for a medical monitor. In *Proceedings of the Human Factors Society 32nd Annual Meeting* (pp. 435–439). Santa Monica, CA: Human Factors and Ergonomics Society.

## 7 VISUAL DISPLAY

This section presents design specifications for visual display of information by computer workstations.

### 7.1 Purpose and Scope

The purpose of this chapter is to establish human factors engineering requirements and recommendations for visual display of text, data, and graphics by computer workstations in office environments. The specifications cover monochrome and colored displays and, in particular, those provided by *cathode ray tube* (CRT) and flat-panel technologies. The specifications in this chapter are useful for but not limited to

- Displays used to perform office text-, data-, and graphics-processing tasks
- Displays of alphanumeric characters in Latin-origin type families
- Display systems capable of presenting 100 or more alphanumeric characters simultaneously

The specifications do not apply to visual displays for auxiliary office equipment, such as hard-copy printers, hand-held devices, or control-panel displays for copiers and telephone systems.

Quantitative guidelines are intended to be applicable to the 90% of the population with normal or closest-to-normal vision.

Definitions of technical terms not found in the relevant sections here can be found in the VESA FPDM standard (VESA, 2001).

### 7.2 General Specifications

This section presents specifications applicable to all visual displays considered in the standard. These general specifications define a default configuration for a display device. Although actual display configurations used in workplaces may differ substantially, a known default configuration provides a point of reference for assessment of display performance.

#### 7.2.1 DEFAULT CONFIGURATION

The *default configuration* is a configuration, including at least the specifications in Table 7-1, in which the display meets the requirements of this standard.

The supplier **should**

- Specify at least one default configuration for the display. If none is specified, the default specified in Table 7-1 applies

**Table 7-1. Default Display Configuration**

**Viewing characteristics.**

Design viewing distance	50 cm
Gaze angle	-15 deg
Design angular viewing envelope	+/- 40 deg horizontal, +/- 30 deg vertical

**Temporal properties**

Response time	13 msec
Refresh rate	75 frames/sec

**Luminance and color**

Maximum luminance available	100 cd/sq m
Maximum luminance/ambient contrast	10:1
Image polarity	Black on white
Default color set	Red, green, blue, yellow, brown, orange, pink, purple, black, grey, and white
Color gamut	50% (area metric)

**Spatial properties**

Pixel pitch	0.3 mm/pixel
Pixel size	0.2 mm width at half height for CRTs
Fill factor	90% fill factor for flatpanel displays

As many visual display systems allow users to adjust viewing conditions and display parameters, installed systems tend to vary from the default configuration. Although a display often is acceptable under conditions that differ from the default configuration, it is necessary to establish a set of conditions under which a given display system meets all the requirements of the standard.

**7.2.2 VIEWING CHARACTERISTICS.**

The viewing characteristics specify an intended geometry between the display and a user, such as viewing distance and viewing angle. These specifications are based on ergonomic considerations. However, users of installed systems may prefer and adopt different conditions, and a display may be set up differently from the default configuration in a workstation, provided that the requirements of the standard are met.

**7.2.2.1 Design Viewing Distance**

The *viewing distance* is the distance between the nasal bridge in any reference posture (see Figure 7-1) and the center of the screen image area. The *design viewing distance* is a viewing distance, specified by the manufacturer, at which all the requirements of this standard can be met.

The minimum design viewing distance **should** be

- 40 cm



Design viewing distance is intended to establish a condition under which a display meets all applicable requirements of this standard. A display may meet the requirements of this standard at greater viewing distances. Work with the displays available in 1988–1991 found that viewers considered a 50–cm distance too close for typical computer workstation tasks (Jaschinski-Kruza, 1988, 1990, 1991) and that greater visual fatigue was associated with a 50–cm viewing distance than with a 100–cm viewing distance (Jaschinski-Kruza, 1990). More recent work (Jaschinski, Heuer, & Kylian, 1998; Psihogios, Sommerich, Mirka, & Moon, 2001; Sommerich, Joines, & Psihogios, 2001) has shown that most users prefer viewing distances from 75 to 83 cm. Viewing distances closer than a typical viewer’s resting focus, which is typically about 67 cm but varies from 29 to 192 cm in the reference population (Andre & Owens, 1999; Leibowitz & Owens, 1978), require greater effort for accommodation and convergence than do further distances (Collins, O’Meara, & Scott, 1975; Fisher, 1977). Thus, the preferred viewing distance of a typical user is likely to exceed 40 cm. All this assumes normal or corrected-to-normal vision and an age less than 40 years, because many viewers older than 40 are unable to accommodate to a display 40 cm away without spectacles or other optical assistance (Turner, 1958).

### 7.2.2.2 Gaze Angle

The entire visual area of a visual display terminal workstation **should** be located between 0° (eye level) and 60° below eye level when the user assumes the upright sitting, declined sitting, or standing reference posture. The center of the visual display screen **should** be located 15° to 20° below eye level

The large body of literature on the gaze angles that are preferred, most comfortable, and best for performance (summarized by (Psihogios et al., 2001; Sommerich et al., 2001) shows that by all three criteria, the best gaze angle is about –17° or slightly higher (Burgess-Limerick, Mon-Williams, & Cappard, 2000).

### 7.2.2.3 Design Angular Viewing Envelope

The *viewing angle* is the angle between the normal at the center of the display surface and a line from the same point to the nasal bridge. The *design angular viewing envelope* is the maximal viewing angles at which all the requirements of this standard are met, including such things as luminance, color, contrast, and character size.

The design angular viewing envelope **should** span at least  $\pm 40^\circ$  horizontally and from  $+30^\circ$  to  $-20^\circ$  vertically

The characteristics of many displays, such as CRTs, vary little over a wide range of viewing angles (Conrac Division, 1985). However, the luminance, color, and contrast of other displays, such as flat-panel displays, do vary with increasing viewing angle, so much so that the contrast can reverse. Some flat-panel displays are designed to be viewed at angles other than perpendicular. Thus, this section calls attention to the importance of defining the range of viewing angles over which the applicable requirements are met. Figure 7-1 shows the design angular viewing envelope as an asymmetrical cone: The center of the screen can be viewed along any line of sight that forms an angle in the horizontal plane of less than 40° with the perpendicular at the center of the screen and, in the vertical plane, less than 30° from above or less than 20° from below the perpendicular. Thus, the design angular viewing envelope limits the range of locations from which the center of the display can be viewed while meeting all the requirements of the standard, such as luminance, color, contrast, and character size.

However, given a fixed viewing location, the angle of the line of sight with respect to the surface of the display varies across the display. This variation limits the area of the display at which all the requirements of the standard can be met. This limited area of the display is defined by an ellipse, shown in Figure 7-2, that is identical to a cross-section of the cone depicted in Figure 7-1; its horizontal axis is 1.68 times the viewing distance,  $v$ , and the vertical axis is asymmetrical, extending 0.36 times the viewing distance above the center of the screen and 0.59 times the viewing distance below the center of the screen. These limits on the display area are even smaller if the display is designed to be viewed at an eccentric angle. (For simplicity, the spatial separation of the two eyes is ignored in this section.)

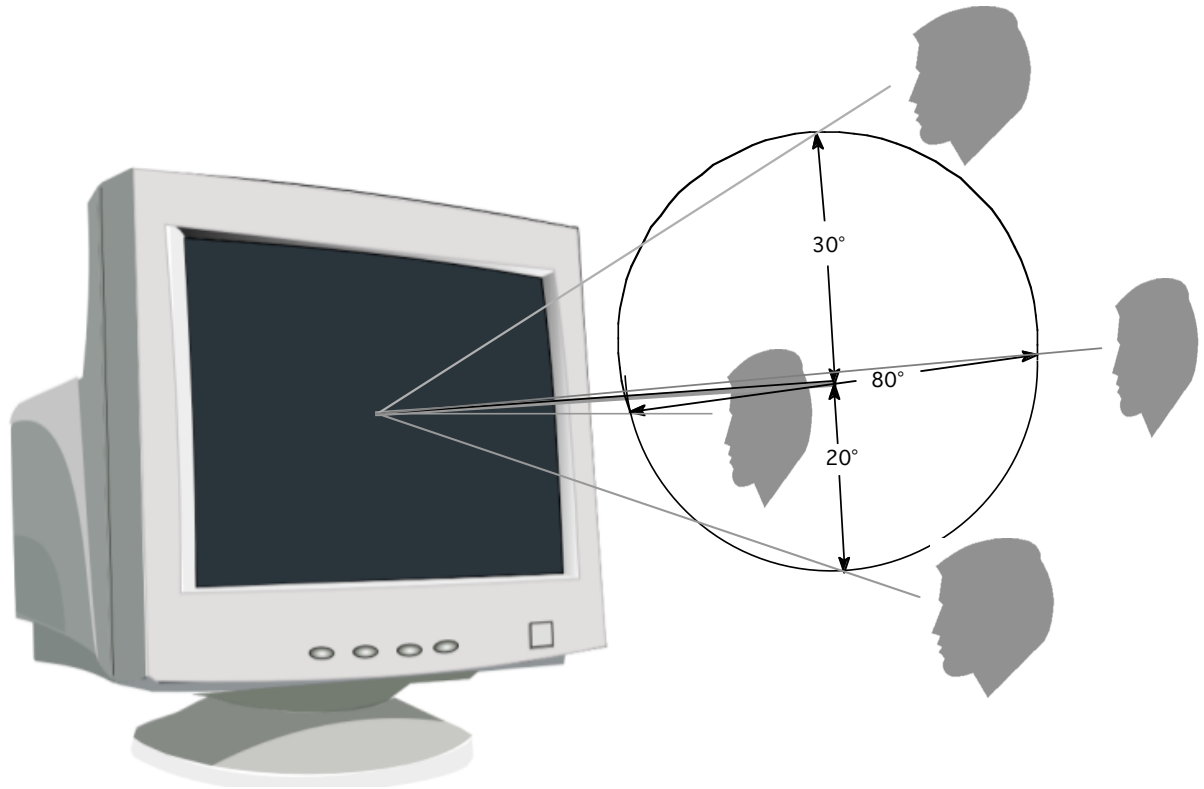

**Figure 7-1. Design angular viewing envelope. When the display surface is viewed from locations outside the design angular viewing envelope, some requirements of the standard, such as contrast luminance, color, contrast, or character size, might not be met (not to scale).**

### 7.2.3. SPATIAL CHARACTERISTICS

As contemporary displays most often consist of discrete picture elements (pixels), the properties of these elements, such as their size, density, and number, determine the spatial characteristics of the display.

#### 7.2.3.1 Moiré

*Moiré* refers to any unwanted periodic pattern, such as arises when the image represented contains spatial frequencies with periods less than twice the distance between adjacent pixels. The contrast of the fundamental spatial frequency of such patterns **should not** exceed the values shown by the heavy line in Figure 7-3.

Such periodic patterns are easily noticed by observers and tend to mask the displayed information. Viewers judge such patterns that are 3 JNDs above threshold to be “definitely noticeable,” and those that are 10 JNDs above threshold to be “probably objectionable” (Carlson & Cohen, 1978; Wittke, 1987). Curves representing an estimate of the contrasts that are 3 and 10 JNDs above threshold are shown in Figure 7-3, and the heavy line is half way between them on a logarithmic scale, that is, 6 JNDs above threshold (Yang & Makous, 1995; Yang, Qi, & Makous, 1995), (A JND is a *just-noticeable-difference*, i.e., the change of contrast necessary to detect the change; 6 JNDs is the contrast reached after six successive increases, each of which was just barely noticeable.)

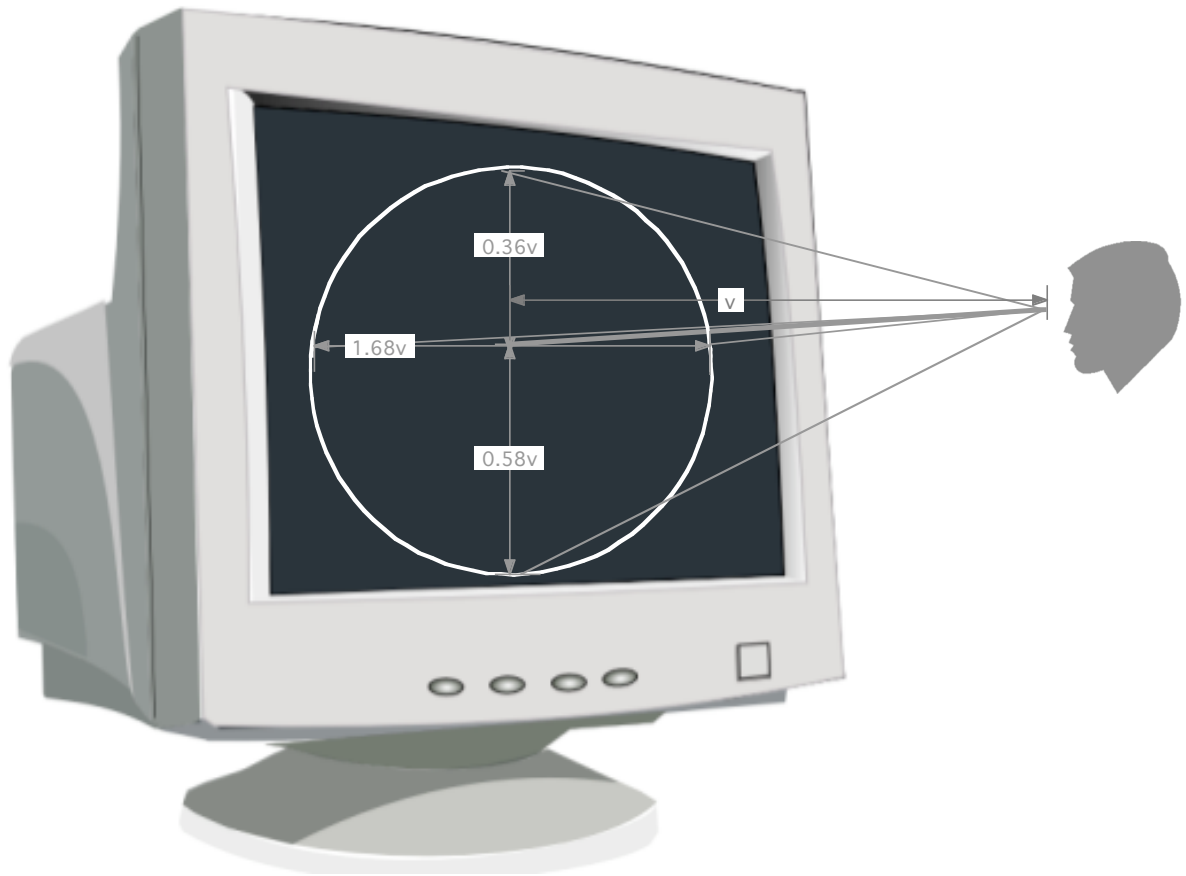

**Figure 7-2. Spatial limits on the display surface imposed by the design angular viewing envelope at the design viewing distance ( $v$ ). Areas of the display surface outside the boundary shown here might not conform to all the requirements of the standard, such as luminance, color, contrast, or character size. This nonconformance occurs when the viewing angle exceeds the angles defined by the design viewing angle envelope (not to scale).**

### 7.2.3.2 Pixel Grid Modulation, Fill Factor, and Pixel Pitch

*Pixel grid modulation* is the difference between the maximum and minimum luminances along a line perpendicular to the raster lines of a CRT display, divided by the sum of these luminances (i.e., the contrast across raster lines). For displays having a pixel density of fewer than 30 pixels per degree of visual angle at the design

viewing distance, the pixel grid modulation **shall not** exceed 0.4 for monochrome and 0.7 for multicolor displays when all pixels are at maximum luminance.

The *fill factor* is the surface available to present information (the pixel area) divided by the total display area. For flat-panel displays having a pixel density of fewer than 30 pixels per degree of visual angle at the design viewing distance, the fill factor **shall** be at least 0.3 and **should** be at least 0.5.

*Pixel pitch*, the distance between adjacent pixels from center to center, is determined by the design viewing distance (Section 7.2.2.1), the height of characters in number of pixels (Section 7.2.6.5), and the height of characters in visual angle (Section 7.2.6.1). For example, if the design viewing distance is 50 cm, the pixel pitch must be 0.25 mm for characters 16 arc minutes high and 0.35 mm for characters 22 arc minutes high. Pixel pitch and the pixel grid modulation jointly determine the minimum pixel size for devices like CRT displays.

A pixel grid modulation greater than 0.2 interferes with legibility of the displayed image (Foley, 1994; Foley & Chen, 1999; Legge & Foley, 1980; Stein, 1978).

Compliance is established by the procedures specified in section 303-3 of the VESA FPDM standard (2001).

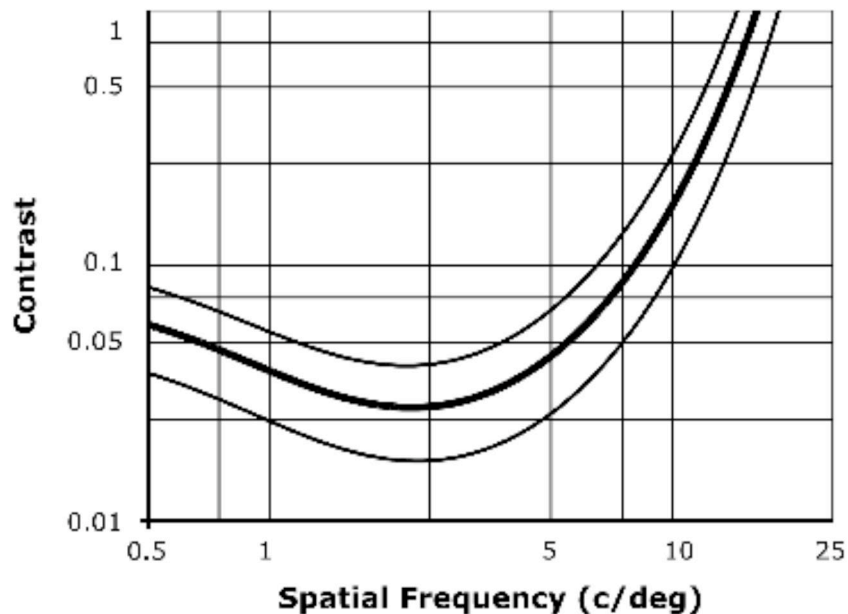

**Figure 7-3. Maximum contrast of moiré patterns. C/deg = cycles per degree of visual angle, and contrast =  $(L_{\max} - L_{\min}) / (L_{\max} + L_{\min})$ , where  $L_{\max}$  is the maximum luminance of the Moiré pattern, and  $L_{\min}$  is its minimum luminance.**

### 7.2.3.3 Pixel and Subpixel Faults

The supplier **shall** specify  $Class_{\text{pixel}}$  of the display. The electronic display **should** be free of pixel and subpixel faults, as defined in section 3.4.13 of ISO 13406-2 (ISO, 2001).

Compliance is established by the procedures specified in section 303-6A of the VESA FPDM standard (2001).

#### 7.2.3.4 Geometric Distortion

Waviness and deviations of vertical and horizontal lines from linearity **shall not** exceed 1% of the vertical and horizontal dimensions of the display, respectively

Under ideal conditions, the threshold for detecting deviations from linearity is 0.3% to 0.5% of the length of the lines (Kramer & Fahle, 1996). However, some curvature may be detectable without interfering with performance or being otherwise objectionable.

The waviness of vertical lines **shall not** exceed 5% of the width of the uppercase letter *H* over a distance equal to the distance between the centers of two adjacent lines, and the waviness of horizontal lines **shall not** exceed 5% of the maximal letter height over a distance equal to the distance from the center of one uppercase letter *H* to that of an adjacent uppercase letter *H*.

Compliance is established by the procedures specified in sections 503-2 and 503-3 of the VESA FPDM standard (2001).

#### 7.2.3.5 Graphic Orthogonality Error

is the angular deviation from the perpendicular, between lines intended to be perpendicular.

Deviations from graphic orthogonality **should** be within  $\pm 30$  arc minutes (1% orthogonal distortion, as defined in VESA FPDM, section 503-3A).

Compliance is established by the procedures specified in section 503-3A of the VESA FPDM standard (2001).

### 7.2.4 TEMPORAL QUALITY

#### 7.2.4.1 Response Time

is the time required for luminance changes to pass through 90% of the change.

The response time **shall** be 55 msec or less and **should** be less than the duration of a single frame.

Lengthy response time reduces the contrast of rapidly changing images, especially those that move, and leaves afterimages and visible trails behind moving objects.

Compliance is established by the procedures specified in section 305-1 of the VESA FPDM standard (2001).

#### 7.2.4.2 Temporal Coding

*Temporal coding* consists in rapidly alternating between different contrasts (blinking) as a means of distinguishing different messages.

Temporal coding **should**

- Use no more than three different rates
- Use rates between 1 and 5 Hz that differ by at least 2 Hz
- Have equal time between states if alerting is the primary purpose

- Have more time (e.g., 70%) in the higher contrast state if alerting is not the primary purpose
- Have a single blink rate of 1/3 to 1 Hz where readability is required during blinking

Temporal coding effectively draws attention to critical information and is effective for drawing attention to the periphery of the visual field. The number of blink rates that are effective for coding is limited by human memory for absolute values along a single sensory continuum (Miller, 1956), not by the size of detectable changes in temporal frequency, which is about a 10% change in the range from 1 to 5 Hz (Mandler & Makous, 1984).

### 7.2.4.3 Flicker

The frames of displays with short response times, such as CRT displays, **shall** be refreshed at a rate that exceeds the value defined by the following equations:

$$\text{CFF} = m + n \{\ln[T(f)]\}; \text{ where} \quad (7-1)$$

$$m = 14.62 - 7.89 / \{1 + \exp[-(D - 42.3) / 5.55]\}; \text{ and} \quad (7-2)$$

$$n = 11.33 \{1 - \exp[-(0.735 + D / 46.3)]\}. \quad (7-3)$$

$T(f)$  is the amplitude of the fundamental temporal frequency,  $f$ , of the display, measured in Trolands; and  $D$  is display size in degrees of visual angle.

The Troland value,  $T$ , is obtained by multiplying luminance by the area of the pupil of the eye:

$$T = p(d/2)^2 L_w, \quad (7-4)$$

where  $d$  is the diameter of the pupil of the eye in mm, and  $L_w$  is the mean luminance of the display in  $\text{cd m}^{-2}$ , without reflected light or with the reflected light subtracted from the measured value (see VESA FPDM [2001], section 308-1). Measurement of  $L_w$  is described in VESA FPDM (2001), section 302-1.

The diameter of the pupil of the eye,  $d$ , of a typical observer can be estimated from the empirical equation (Moon & Spencer, 1944):

$$d = 5 - 3 \tanh[0.4 \log(L_T + 1)], \quad (7-5)$$

where  $L_T$  is the mean luminance of the display in  $\text{cd m}^{-2}$ , including any reflected light. Note, however, that under any given set of conditions there are large individual differences in pupil size among different individuals and even in a given individual at different times, and that pupil size tends to diminish with increasing age (Wyszecki & Stiles, 1982).

The fundamental temporal frequency of a display,  $f$ , is normally equal to the rate at which it is refreshed, but it can be measured according to the procedure described in VESA FPDM (2001), section 305-4. Alternatively, if the temporal response of display luminance follows an exponential curve with known time constant,  $a$  (in sec), then the amplitude of the fundamental temporal frequency is given (Farrell, Benson, & Haynie, 1987) by the equation:

$$T(f) = 2T / [1 + a^2 p f^2]^{0.5} \quad (7-6)$$

The response time,  $a$ , can be measured according to the procedure described in VESA FPDM (2001), section 305-1.

Equation 7-1 estimates the minimum refresh rate at which no more than 10% of users report seeing flicker (Farrell et al., 1987). Equations 7-2 and 7-3 are empirical descriptions of the results of varying display size (S. Eriksson & Backstrom, 1987). Although the data cover only the range from 10 to 70 degrees, both functions appear to approach an asymptote at the largest display sizes.

Flicker causes modest yet reliable increases in subjective reports of visual fatigue, increased task difficulty (Harwood & Foley, 1987), and reduced visual acuity (Murch, 1983).

Compliance is established by the measurements described above and by application of equation 7-1 to the results.

#### 7.2.4.4 Jitter

*Jitter* is the unwanted peak-to-peak variation in the geometric location of pixels over time.

Jitter **shall** be less than 0.0002 times the design viewing distance in the frequency range, 0.5 to 30 Hz.

Perception of jitter depends on the frequency and amplitude of the spatial displacement (W. Eriksson, 1992; Tyler & Torres, 1972), and it is most visible at frequencies of 1 to 3 Hz. Above 30 Hz, jitter is perceived as blurring of the image instead of jitter and therefore represents a loss of resolution or contrast instead of perceived jitter. Jitter typically occurs only in CRT and other raster-scanned displays and often results from magnetic fields generated by other devices in the environment, such as motors, ballast transformers for fluorescent lamps, and other display units.

Compliance is established by the procedures specified in section 305-6 of the VESA FPDM standard (2001).

### 7.2.5 LUMINANCE AND COLOR QUALITY

#### 7.2.5.1 Luminance Range

The display **shall** be capable of producing a luminance of at least 35 cd/m<sup>2</sup>, and it **should be** capable of producing least 100 cd/m<sup>2</sup>.

Users often prefer high display luminance (e.g., 100 cd/m<sup>2</sup> or greater), particularly under high ambient illumination. Moreover, reading speed and accuracy increase with increasing luminance, and legibility decreases below 35 cd/m<sup>2</sup> (Blackwell, 1946; Chung, Mansfield, & Legge, 1998; Giddings, 1972; Legge, Parish, Luebker, & Wurm, 1990; Legge, Pelli, Rubin, & Schleske, 1985; Legge, Rubin, & Luebker, 1987; Strasburger, Harvey, & Rentschler, 1991), as does color discrimination (Legge et al., 1990; Pokorny & Smith, 1986).

Compliance is established by the procedures specified in section 302-1 of the VESA FPDM standard (2001).

### 7.2.5.2 Luminance Nonuniformity

*Luminance nonuniformity* is the ratio of the maximum display luminance (usually at the center) to the minimum (usually at a corner) when each is averaged over a 1 deg area at the design viewing distance.

The ratio of maximum luminances to minimum luminances of a display intended to be uniform **shall** be 1.7 to 1 or less.

The luminance of a typical CRT display decreases gradually from the center. The ratio 1.7 to 1 is below the threshold of detectability for widely separated targets (Olzak & Thomas, 1986).

Compliance is established by the procedures specified in section 306-1 of the VESA FPDM standard (2001).

### 7.2.5.3 Luminance Contrast and Reflections

The display **shall**

- Exhibit a contrast ratio of at least 3 to 1 under all office illumination conditions

The display **should**

- Exhibit a contrast ratio of at least 3 to 1 under specular illumination from a 1000 cd/m<sup>2</sup> uniform source of subtense 15° in a 15° specular configuration (see VESA FPDM 308-4 using a 1000 cd/m<sup>2</sup> source)
- Exhibit a 3 to 1 full-screen contrast ratio or better under uniform ambient illumination of 1000 lx (see VESA FPDM 308-2)

If the 3 to 1 ratio cannot be met, change the location or orientation of the display so that it does not face windows or other sources of bright light.

Visibility improves with increasing contrast up to a contrast ratio of 3 to 1, above which it rapidly levels off (Legge et al., 1987; Legge et al., 1990; Strasburger et al., 1991). Luminance contrast is required because purely chromatic contrasts have poor visibility (Anderson, Mullen, & Hess, 1991; Chen & Yu, 1996; Legge et al., 1987; Legge et al., 1990; Mullen, 1985; Sekiguchi, Williams, & Brainard, 1993). Aside from this low sensitivity of the visual system to isoluminant stimuli, the failure of isoluminant contrast to drive accommodation (Switkes, Bradley, & Schor, 1990; Wolfe & Owens, 1981) can further reduce retinal contrast, depending on the distance of the display relative to the distance of the observer's resting accommodation (Andre & Owens, 1999; Leibowitz & Owens, 1978). Note also that 8%–10% of males of European ancestry have difficulty discriminating reds from greens (Pokorny & Smith, 1986).

Excessive reflections from the display reduce display contrast and therefore legibility, and users object to them (Kubota, 1994; Kubota & Takahashi, 1989; Pawlak & Roll, 1990). Note that reflection of light from any source by an ordinary polished glass surface creates a virtual image with a luminance anywhere from 4% to 100% of that of the source itself, depending on the angle of incidence. Possible sources of reflected light include the sun, at 10<sup>9.5</sup> cd/m<sup>2</sup>; filaments of tungsten sources, at 10<sup>6.3</sup> cd/m<sup>2</sup>; fluorescent tubes, at 10<sup>4.2</sup> cd/m<sup>2</sup>; blue sky, at 3.4 cd/m<sup>2</sup>, and white office walls or desktops, at 10<sup>2.1</sup> cd/m<sup>2</sup> (Makous, 1998). Hence, even reflections from the walls can be excessive, and direct reflections from almost any



light source are likely to be excessive. The best solution is often careful planning of the environment, including use of task lighting.

Compliance is established by the procedures specified in sections 308-2 and 308-4 of the VESA FPDM standard (2001), except that, for the 3 to 1 contrast ratio, the illumination of the display is provided by light sources in the workplace where the display is being used.

#### 7.2.5.4 Luminance Coding

*Luminance coding* consists in distinguishing different messages by difference in luminance of the symbols.

Luminance code levels **shall** have a ratio greater than or equal to 1.5 to 1.

The lowest luminance code level above black **shall** exceed 20 cd/m<sup>2</sup>.

Luminance code levels **should not** exceed 3 in number (e.g., black, gray, and white).

The *number* of luminance levels used for coding is limited by human memory for absolute values along a sensory continuum (Miller, 1956), not by the luminance ratio that can be detected. The *difference* between luminance levels is limited by human visual abilities. The visual threshold for luminance differences in small fields (e.g., 10 arc minutes) at low luminance (e.g., 35 cd/m<sup>2</sup>) is about 10% (Olzak & Thomas, 1986); the specified ratio of 1.5 to 1 provides a readily detectable luminance difference.

Compliance is established by the procedures specified in section 304-2 of the VESA FPDM standard (2001).

#### 7.2.5.5 Image Polarity

*Image polarity* depends on whether the characters or their background has the higher luminance. When the characters are darker than their background, polarity is positive, and vice versa.

If a display provides both image polarities, it **shall** meet the requirements of this standard in both image polarities.

Each polarity has advantages (Bauer & Cavonius, 1980). For example, with positive polarity, specular reflections are less perceptible, edges appear sharper, and luminance balance is easier to obtain. Positive polarity is preferred for ordinary office tasks. With negative polarity, flicker (7.2.4.3) is less perceptible, moiré (section 7.2.3.1) is less perceptible, and characters may be perceived as larger than they are. Many display workstations offer both polarities and sometimes both polarities simultaneously in different parts of the display.

Compliance is established by the procedures specified in the corresponding sections of this standard.

#### 7.2.5.6 Default Color Set

When an application requires the user to discriminate or identify colors, it **shall** offer a default set of colors that meets the requirements of this standard. If the user can alter the color, the default colors set **shall** be retrievable and restorable.

The default color set **should** contain no more than 11 members (including both the dimensions of luminance and chromaticity). Good choices for colors are red, green, blue, yellow, brown, orange, pink, purple, black, grey, and white.

These are the basic colors, and the number 11 is based on the number of basic colors (Boynton & Olson, 1990).

As 8% of males (and approximately 0.5% of females) of European descent cannot discriminate certain green colors from certain red colors (i.e., are red-green color-blind), to ensure that the displayed information is available to these individuals, such information **should not** depend solely on a red-green discrimination.

Compliance is established by inspection of the display and its software.

#### 7.2.5.7 Color Differences

The color difference,  $DE_{uv}^*$  (CIE, 1994), between colors that are to be discriminated **should** be greater than 20.

This metric reflects the detectability of the difference between two colors (Carter & Carter, 1981). Differences along the dimension of blueness are especially difficult to see when the targets are small (small-field tritanopia), owing to the absence of cones sensitive to short wavelengths in the central fovea (Curcio et al., 1991). Note that when one color is presented as a target against a background of another color, the apparent color difference can be either greater (simultaneous contrast) or less (assimilation) than it is when viewed side-by-side (Kaiser & Boynton, 1996). See also the note in Section 7.2.5.6 on color blindness.

#### 7.2.5.8 Color Uniformity

The chromaticity differences of a color,  $Du_{uv}$ , at different locations on the display that is intended to be uniform **should** be no greater than 0.03 and no greater than 0.02 within any area subtending less than  $35^\circ$  of visual angle

The ability of the eye to detect chromaticity differences decreases with increasing separation of targets (Sharpe & Wyszecki, 1976).

#### 7.2.5.9 Number of Colors

If rapid visual search based on color discrimination is required, a subset of no more than six of the default color set **should** be used.

If the meaning of a color is to be recalled from memory, a subset of no more than six of the default color set **should** be used, and if more than six colors are used, their meanings **shall** be readily accessible.

Compliance is established by inspection of the display and its software.

#### 7.2.5.10 Background/Foreground Interactions

Extreme blue ( $v_{uv}$ , 0.2) and extreme red ( $u_{uv}$ , 0.4) **should not** be used in the same display, and neither **shall** be used as a background for the other.

Either the foreground or background **should** be achromatic.

Simultaneous presentation of more than one color always produces axial chromatic aberrations, which defocus some wavelengths when others are in focus. Lateral

chromatic aberrations displace some wavelengths laterally more than others; when such displacements differ in fellow eyes, spurious depth signals result. Greater wavelength differences cause greater chromatic aberrations. Introducing color differences between foreground and background also reduces luminance contrast below what it would be if only black and white were used. Note that the optical properties of flat panels, especially their dependence on viewing angle, may affect performance more than the properties of the visual system itself.

Spatial resolution of color differences is worse than that of achromatic differences and is worse between yellows and blues than between reds and greens (Anderson et al., 1991; Mullen, 1985; Olzak & Thomas, 1986; Sekiguchi et al., 1993).

Note that 2% of males of European ancestry are insensitive to red light (Pokorny & Smith, 1986).

Compliance is established by inspection of the display and its software.

## 7.2.6 INFORMATION FORMAT

### 7.2.6.1 Character Height

The minimum character height (see Figure 7-4) **shall** be 16 arc minutes and **should** be 22 to 30 arc minutes at the design viewing distance, except where speed of recognition is unimportant, such as footnotes and subscripts and superscripts, in which case character height **should** be at least 10 arc minutes.

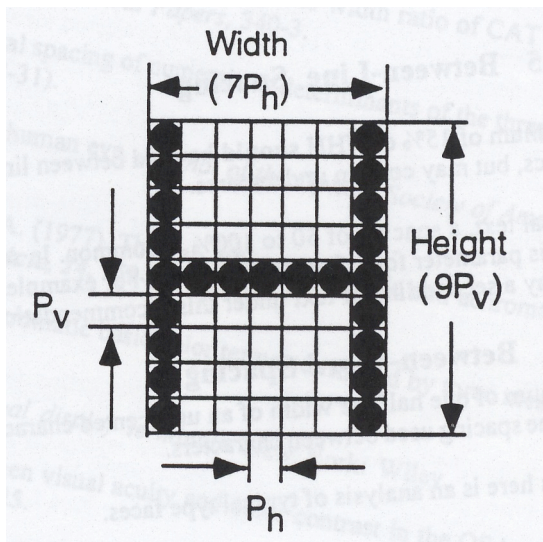

**Figure 7-4. Height and width of characters. The height and width of characters are defined by these figure[EQ: “figure” means grids or pixels?]. Squares represent pixels.  $P_v$  and  $P_h$  represent the vertical and horizontal dimensions of a pixel, respectively.**

For rapid and accurate identification of individual characters, 16 to 18 minutes of arc is normally adequate, although reading speed continues to increase until character height exceeds 22 arc minutes (Chung et al., 1998; Giddings, 1972; Legge et al., 1985; Legge et al., 1987; Legge et al., 1990; Strasburger et al., 1991). Increasing character size by too much slows reading by reducing the number of characters that can be viewed foveally during a fixation (Arditi, Knoblauch, & Grunwald, 1990; Legge et al., 1987).

Warnings or other essential information requires larger characters to ensure that individuals with low vision (visual acuity of 20/70 or less) can read it.

Compliance is established by inspection of the display under sufficient magnification to resolve individual pixels.

#### 7.2.6.2 Sizes of Colored Characters

Where discrimination of the colors of alphanumeric strings is required, the character height (see Figure 7-4) **should** subtend at least 20 arc minutes at the design viewing distance.

Where accurate color discrimination of an individual character or symbol is required, the image **should** subtend at least 30 arc minutes at the design viewing distance.

These criteria distill complex interactions among the variables of luminance, chromaticity, and space into a few simple rules of thumb (Chen & Yu, 1996; Legge et al., 1990). Note that colors that are either the same luminance or the same dominant wavelength are especially hard to discriminate (Chen & Yu; Sekiguchi et al., 1993).

#### 7.2.6.3 Character Width-to-Height Ratio

Character width-to-height ratio is based on an uppercase letter, *H*, without serifs.

A width-to-height ratio (“Width”/“Height” in Figure 7-4) **shall** be from 0.5 to 1 to 1 and, for optimal legibility and readability, **should** be from 0.6 to 1 to 0.9 to 1. Legibility is sometimes sacrificed to some extent for esthetics, conservation of space, or other practical considerations (Benson, L., & Farrell, 1988; Soar, 1955).

Compliance is established by inspection of the display under sufficient magnification to resolve individual pixels.

#### 7.2.6.4 Stroke Width

The stroke width of characters (a multiple of “ $P_h$ ” and “ $P_v$ ” in Figure 7-4) **shall** be from 1/6 to 1/12 of the maximal character height (see Figure 7-4). Wider strokes are better for positive polarity than for negative polarity (Berger, 1944; Grether & Baker, 1972; Kuntz & Sleight, 1950; Shapiro, 1951; Uhlaner, 1941).

Compliance is established by inspection of the display under sufficient magnification to resolve individual pixels.

#### 7.2.6.5 Character Format

Latin alphanumeric characters **shall** be at least 9 pixels high and 7 pixels wide (see Figure 7-4) for tasks requiring continuous reading or identification of individual characters. Uppercase letters and numerals **shall** be at least 7 pixels high and 5 pixels wide. Subscripts, superscripts and the numerals in fractions **shall** be at least 5 pixels high and 4 pixels wide. The minimum height **shall** be increased by at least 2 pixels if lower case letters are used (to accommodate descenders), and the minimum height **shall** be increased by at least 2 pixels if diacritic marks are used. The minimum widths do not apply to the characters, *l*, *i*, *l*, *j*, *J*, and *l*.

Compliance is established by inspection of the display under sufficient magnification to resolve individual pixels.

### 7.2.6.6 Spacing Between Characters

The spacing between characters,  $S_c$ , without serifs **shall** be at least equal to the stroke width and **should** be 25% to 60% of the width of the uppercase letter  $H$  (see Figure 7-4). The spacing between characters,  $S_c$ , with serifs **shall** be at least one pixel (see Figures 7-4 and 7-5).

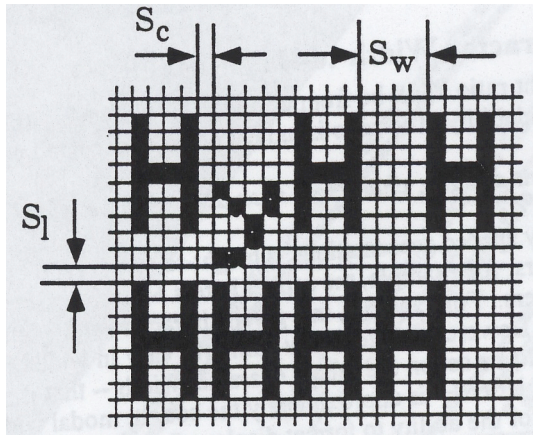

**Figure 7-5. Spacing between characters ( $S_c$ ), lines ( $S_l$ ), and words ( $S_w$ ). Squares represent pixels.**

This recommendation concerns both the effects of crowding (Arditi et al., 1990; Chung, Levi, & Legge, 2001; Leat, Li, & Epp, 1999; Martelli, Majaj, & Pelli, 2005; Pelli, Palomares, & Majaj, 2004; Strasburger et al., 1991) and degraded legibility caused by excessive spacing.

Compliance is established by inspection of the display under sufficient magnification to resolve individual pixels.

### 7.2.6.7 Spacing Between Lines

The space between lines of text ( $S_l$  in Figure 7-5), including diacritics, **shall** be at least one pixel (see Figures 7-4 and 7-5) and **should** be at least 15% of the maximal character height (see Figure 7-4). Users with partial vision require larger spacing, 25% to 30% of the character height.

Compliance is established by inspection of the display under sufficient magnification to resolve individual pixels.

### 7.2.6.8 Spacing Between Words

The spacing between words ( $S_w$  in Figure 7-5) **shall** exceed the spacing between characters ( $S_c$  in Figure 7-5) and **should** be at least half the width of an uppercase letter  $H$  without serifs (see Figure 7-4).

Compliance is established by inspection of the display under sufficient magnification to resolve individual pixels.

### 7.3 References

- Anderson, S. J., Mullen, K. T., & Hess, R. F. (1991). Human peripheral spatial resolution for achromatic and chromatic stimuli: Limits imposed by optical and retinal factors. *Journal of Physiology (London)*, 442, 47–64.
- Andre, J. T., & Owens, D. A. (1999). Predicting optimal accommodative performance from measures of the dark focus of accommodation. *Human Factors*, 41, 139–145.
- Arditi, A., Knoblauch, K., & Grunwald, I. (1990). Reading with fixed and variable character pitch. *Journal of the Optical Society of America A*, 7(10), 2011–2015.
- Bauer, D., & Cavonius, C. (1980). Improving the legibility of visual display units through contrast reversal. In E. Grandjean & E. Vigliani (Eds.), *Ergonomic aspects of visual display terminals* (pp. 137–142). London: Taylor and Francis.
- Benson, D. C. L. B., & Farrell, J. E. (1988). The effect of character height-to-width ratio of CAT display legibility. *Society of Information Display, Digest of Technical Papers*, 340–343.
- Berger, C. (1944). Stroke-width, form and horizontal spacing of numerals as determinants of the threshold of recognition. *Journal of Applied Psychology*, 28, 208–231.
- Blackwell, H. R. (1946). Contrast thresholds of the human eye. *Journal of the Optical Society of America*, 36(11), 624–643.
- Boynton, R. M., & Olson, C. X. (1990). Salience of chromatic basic color terms confirmed by three measures. *Vision research*, 30(9), 1311–1317.
- Burgess-Limerick, R., Mon-Williams, M., & Cappard, V. L. (2000). Visual display height. *Human Factors*, 42, 140–150.
- Carlson, D. R., & Cohen, R. W. (1978). *Visibility of displayed information* (ONR-CR213-120-4F): Office of Naval Research.
- Carter, E. C., & Carter, R. C. (1981). Color and conspicuousness. *Journal of the Optical Society of America*, 71(6), 723–729.
- Chen, T.-L., & Yu, C.-Y. (1996). The relationship between visual acuity and color contrast in the OSA uniform color space. *Color Research and Application*, 21(1), 18–25.
- Chung, S. T., Mansfield, J. S., & Legge, G. E. (1998). Psychophysics of reading. XVIII. The effect of print size on reading speed in normal peripheral vision. *Vision Research*, 38(19), 2949–2962.
- Chung, S. T. L., Levi, D. M., & Legge, G. E. (2001). Spatial-frequency and contrast properties of crowding. *Vision Research*, 41(14), 1833–1850.
- Collins, C. C., O'Meara, D., & Scott, A. B. (1975). Muscle tension during unrestrained human eye movements. *Journal of Physiology (London)*, 245, 351–369.
- Commission Internationale de L'Eclairage. (CIE). (1994). *Industrial Colour-Difference Evaluation* (p. 116–1995): Commission Internationale de L'Eclairage.
- Conrac Division, C. C. (1985). *Raster graphics handbook*. New York: Van Nostrand Reinhold Company.
- Curcio, C. A., Allen, K. A., Sloan, K. R., Lerea, C. L., Hurley, J. B., Klock, I. B., et al. (1991). Distribution and morphology of human cone photoreceptors stained with anti-blue opsin. *Journal of Comparative Neurology*, 312, 610–624.
- Eriksson, S., & Backstrom, L. (1987). Temporal and spatial stability in visual displays. In B. Knave & P-G. Wideback (Eds.), *Work with display units*. Amsterdam: North Holland.
- Eriksson, W. (1992). Perceptual thresholds for jitter in VDUs. *Displays*, 13(4), 187–192.

- Farrell, J. E., Benson, B. L., & Haynie, C. R. (1987). Predicting flicker thresholds for video display terminals. *Proceedings of the Society for Information Display*, 28, 449–453.
- Fisher, R. F. (1977). The force of contraction of the human ciliary muscle during accommodation. *Journal of Physiology (London)*, 270, 51–74.
- Foley, J. M. (1994). Human luminance pattern-vision mechanisms: Masking experiments require a new model. *Journal of the Optical Society of America A*, 11, 1710–1719.
- Foley, J. M., & Chen, C. C. (1999). Pattern detection in the presence of maskers that differ in spatial phase and temporal offset: Threshold measurements and a model. *Vision Research*, 39(23), 3855–3872.
- Giddings, B. J. (1972). Alpha-numerics for raster displays. *Ergonomics*, 15(1), 65–72.
- Grether, W. F., & Baker, C. A. (1972). Visual presentation of information. In H. P. V. Cott & R. G. Kincade (Eds.), *Human engineering guide to equipment design* (pp. 41–121). New York: McGraw-Hill.
- Harwood, K., & Foley, P. (1987). Temporal resolution: An insight into the video display terminal (VDT) "Problem." *Human Factors*, 29, 447–452.
- International Organization for Standardization. (ISO). (2001). *ISO 13406-2: Ergonomic requirements for work with visual displays based on flat panels—Part 2: Ergonomic requirements for flat panel displays*. Geneva: Author.
- Jaschinski, W., [AQ: Jaschinski or Jachinski?] Heuer, H., & Kylian, H. (1998). Preferred position of visual displays relative to the eyes: A field study of visual strain and individual differences. *Ergonomics*, 41, 1034–1049.
- Jaschinski-Kruza, W. (1988). Visual strain during VDU work: The effect of viewing distance and dark focus. *Ergonomics*, 31, 1449–1465.
- Jaschinski-Kruza, W. (1990). On the preferred viewing distances to screen and document at VDU workplaces. *Ergonomics*, 33, 1055–1063.
- Jaschinski-Kruza, W. (1991). Eyestrain in VDU users: Viewing distance and the resting position of ocular muscles. *Human Factors*, 33, 69–83.
- Kaiser, P. K., & Boynton, R. M. (1996). *Human Color Vision* (2nd ed.). Washington, DC: Optical Society of America.
- Kramer, D., & Fahle, M. (1996). A simple mechanism for detecting low curvatures. *Vision Research*, 36(10), 1411–1419.
- Kubota, S. (1994). *Effects of surface reflection properties of VDT screens on subjective ratings of the reflected glare disturbances from the different size sources. (ISO/CD 9241-7.3: Ergonomics—Requirements for office work with visual display terminals [VDTS]—Part 7.3: Display requirement with reflections.)*
- Kubota, S., & Takahashi, M. (1989). Permissible luminance of disturbing reflections of light sources on CRT displays. *Japan Illuminating Engineering Society Journal*, June, 314–318.
- Kuntz, J. E., & Sleight, R. B. (1950). Legibility of numerals: The optimal ratio of height to width of stroke. *American Journal of Psychology*, 63, 567–575.
- Leat, S. J., Li, W., & Epp, K. (1999). Crowding in central and eccentric vision: The effects of contour interaction and attention. *Investigative Ophthalmology and Visual Science*, 40(2), 504–512.
- Legge, G. E., & Foley, J. M. (1980). Contrast masking in human vision. *Journal of the Optical Society of America*, 70, 1458–1471.
- Legge, G. E., Parish, D. H., Luebker, A., & Wurm, L. H. (1990). Psychophysics of reading. XI. Comparing color contrast and luminance contrast. *Journal of the Optical Society of America A*, 7, 2002–2010.
- Legge, G. E., Pelli, D. G., Rubin, G. S., & Schleske, M. M. (1985). Psychophysics of reading—I. Normal vision. *Vision Research*, 25(2), 239–252.
- Legge, G. E., Rubin, G. S., & Luebker, A. (1987). Psychophysics of reading—V. The role of contrast in normal vision. *Vision Research*, 27(7), 1165–1177.

- Leibowitz, H. W., & Owens, D. A. (1978). New evidence for the intermediate position of relaxed accommodation. *Documenta Ophthalmologica*, 46, 133–147.
- Makous, W. (1998). Optics and photometry. In R. H. S. Carpenter & J. G. Robson (Eds.), *Vision research: A practical guide to laboratory methods* (pp. 1–49). Oxford, England: Oxford University Press.
- Mandler, M. B., & Makous, W. (1984). A three channel model of temporal frequency perception. *Vision Research*, 24, 1881–1887.
- Martelli, M., Majaj, N. J., & Pelli, D. G. (2005). Are faces processed like words? A diagnostic test for recognition by parts. *Journal of Vision*, 5(1), 58–70.
- Miller, G. A. (1956). The magical number seven, plus or minus two: Some limits on our capacity for processing information. *Psychological Review*, 63(2), 81–97.
- Moon, P., & Spencer, D. E. (1944). Visual data applied to lighting design. *Journal of the Optical Society of America*, 34, 605.
- Mullen, K. T. (1985). The contrast sensitivity of human colour vision to red-green and blue-yellow chromatic gratings. *Journal of Physiology*, 359, 381–400.
- Murch, G. M. (1983). Visual fatigue and operator performance with DVST and raster displays. *Proceedings of the Society for Information Display*, 24(1), 53–61.
- Olzak, L. A., & Thomas, J. P. (1986). Seeing spatial patterns. In K. R. Boff, L. Kaufman, & J. P. Thomas (Eds.), *Handbook of perception and human performance* (Vol. 1, Chapter 7. New York: Wiley.
- Pawlak, U., & Roll, K.-F. (1990). Setting levels for reflected luminance. *Siemens Review*.
- Pelli, D. G., Palomares, M., & Majaj, N. J. (2004). Crowding is unlike ordinary masking: Distinguishing feature integration from detection. *Journal of Vision*, 4(12), 1136–1169.
- Pokorny, J., & Smith, V. C. (1986). Colorimetry and color discrimination. In K. R. Boff, L. Kaufman, & J. P. Thomas (Eds.), *Handbook of perception and human performance* (Vol. I, pp. 8-1–8-51). New York: Wiley.
- Psihogios, J. P., Sommerich, C. M., Mirka, G. M., & Moon, S. D. (2001). A field evaluation of monitor placement effects in VDT users. *Applied Ergonomics*, 32(4), 313–325.
- Sekiguchi, N., Williams, D. R., & Brainard, D. H. (1993). Efficiency in detection of isoluminant and isochromatic interference fringes. *Journal of the Optical Society of America A*, 10, 2118–2133.
- Shapiro, H. B. (1951). Factors affecting the legibility of digits. *The American Psychologist*, 6, 364.
- Sharpe, L. T., & Wyszecki, G. (1976). Proximity factor in color-difference evaluations. *Journal of the Optical Society of America*, 66, 40–49.
- Soar, R. S. (1955). Height-width proportion and stroke width in numeral visibility. *The Journal of Applied Psychology*, 39, 43–79.
- Sommerich, C. M., Joines, S. M. B., & Psihogios, J. P. (2001). Effects of computer monitor viewing angle and related factors on strain, performance and preference outcomes. *Human Factors*, 43, 39–55.
- Stein, I. H. (1978). *The effect of active area on the legibility of dot matrix displays*. Fort Monmouth, NJ: U.S. Army Electronics Research and Development Command.
- Strasburger, H., Harvey, L. O., Jr., & Rentschler, I. (1991). Contrast thresholds for identification of numeric characters in direct and eccentric view. *Perception & Psychophysics*, 49(6), 495–508.
- Switkes, W., Bradley, A., & Schor, C. (1990). Readily visible changes in color contrast are insufficient to stimulate accommodation. *Vision Research*, 30, 1367–1376.
- Turner, M. J. (1958). Observations on the normal subjective amplitude of accommodation. *British Journal of Physiological Optics*, 15, 428–450.



- Tyler, C. W., & Torres, J. (1972). Frequency response characteristics for sinusoidal movement in the fovea and periphery. *Perception and Psychophysics*, 12, 232–236.
- Uhlner, J. E. (1941). The effects of thickness of stroke on the legibility of letters. *Proceedings of the Iowa Academy of Science*, 48, 319–324.
- Video Electronics Standards Association (VESA). (2001). *Flat panel display measurements standard* (Standard Version 2). Milpitas, CA: VESA, Display Metrology Committee.
- Wittke, J. P. (1987). Moiré considerations in shadow mask picture tubes. *Proceedings of the Society for Information Display*, 28-4, 415–418.
- Wolfe, J. M., & Owens, D. A. (1981). Is accommodation colorblind? Focusing chromatic contours. *Perception*, 10, 53–62.
- Wyszecki, G., & Stiles, W. (1982). *Color Science: Concepts and methods, quantitative data and formulae* (2nd ed.). New York: Wiley.
- Yang, J., & Makous, W. (1995). Modeling pedestal experiments with amplitude instead of contrast. *Vision Research*, 35, 1979–1989.
- Yang, J., Qi, X., & Makous, W. (1995). Zero frequency masking and a model of contrast sensitivity. *Vision Research*, 35, 1965–1978.

## 8 FURNITURE

The specifications presented in this chapter are product centered, and it is intended that furniture designers and manufacturers use them for design purposes. It is recognized that compliant furniture can be configured improperly in a workstation; therefore, additional user-centered specifications for workstation configuration purposes are presented in Chapter 5, Installed Systems.

This chapter presents design specifications for chairs, tables, and accessories used in computer workstations. The furniture specifications are based on anthropometric considerations associated with four basic reference postures: upright sitting, reclined sitting, declined sitting, and standing.

### 8.1 Purpose and Scope

The purpose of this chapter is to establish, for computer workstation furniture, minimum design specifications that support and enhance operator performance during text-, data-, and graphics-processing tasks.

The scope of this chapter covers design features for computer work surfaces, monitor and input-device support surfaces, chairs, and supports for users' feet, wrists, hands, and forearms. These specifications apply to users within an anthropometric range defined by separate gender distributions that include all but the smallest (less than 5th percentile female) and largest (exceeding 95th percentile male) members of the appropriate distributions and who work in one or more of the four reference postures (Chapter 5, Installed Systems). The anthropometric distributions are taken from an extensive survey of U.S. Army personnel, (Gordon et al., 1989). Because of the size and composition (gender and ethnicity) of this survey, it is considered to be the best available representation of the U.S. civilian population.

NOTE 1: The terms "User," "Operator," and "Worker" are used interchangeably in this chapter.

NOTE 2: The anthropometric data used in this standard are not intended to be all inclusive and do not specify designs to accommodate statistical outliers, for example, individuals who are very small, tall or large.

### 8.2 General Specifications

This standard recognizes that VDT users frequently change their working postures to maintain comfort and productivity. Four reference postures are used in this standard to represent a range of postures observed at computer workstations.

# Reference Postures

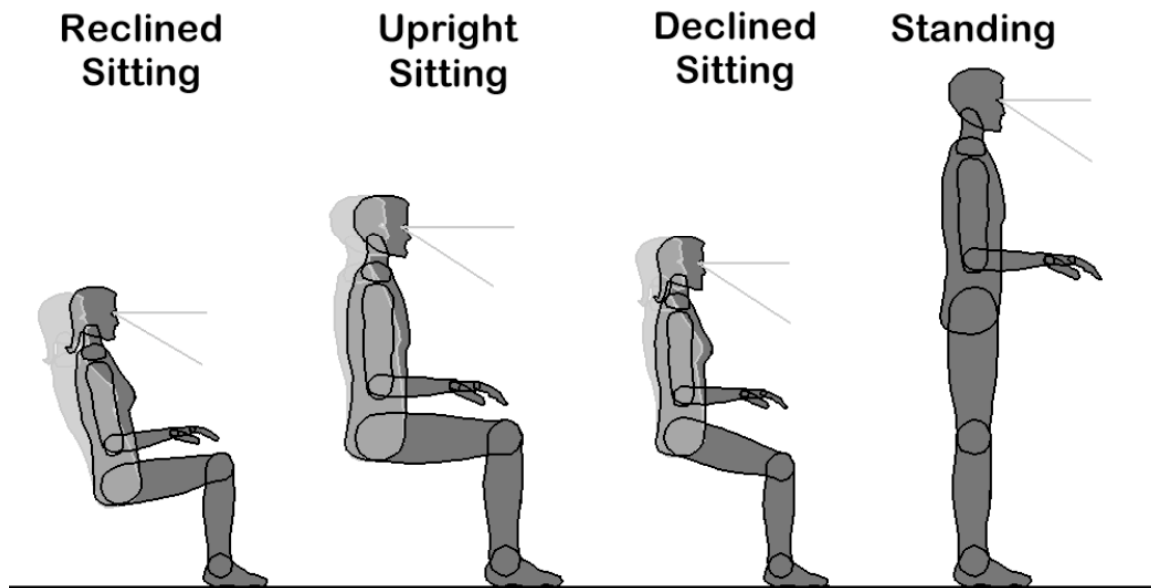

Figure 8-1. Reference postures for computer workstation users.

The four reference postures are characterized as follows:

**Reclined sitting.** In the reclined sitting posture, the user's torso and neck recline between 105 and 120 degrees to the horizontal.

**Upright sitting.** In the upright sitting posture, the user's torso and neck are approximately vertical and in line (between 90 and 105 degrees to the horizontal), the thighs are approximately horizontal, and the lower legs are vertical.

**Declined sitting.** In the declined sitting posture, the user's thighs are inclined below the horizontal, the torso is vertical or slightly reclined behind the vertical, and the angle between the thighs and the torso is greater than 90 degrees.

**Standing.** In the standing posture, the user's legs, torso, neck, and head are approximately in line and vertical.

Users require frequent movement and postural changes to achieve and maintain comfort and productivity (Kroemer, Kroemer, & Kroemer-Elbert, 1994; Sanders & McCormick, 1993). The four reference postures are intended to illustrate the diversity of body positions observed at computer workstations. Because these reference postures are intended as examples of human postures, variations in actual postures observed during work sessions can be expected. However, not all postures are equally comfortable or productive.

## 8.2.1 USER POSTURES

The installed workstation **shall** allow users to adopt postures within the following postural design criteria:

- Elbow angles between 70 and 135 degrees (Cushman, 1984; Grandjean, Hunting, & Pidermann, 1983; Miller & Suther, 1983; Weber, Sancin, & Grandjean, 1984).

- Shoulder abduction angles less than 20 degrees (Chaffin & Andersson, 1984; Karlqvist, Hagberg, Köster, Wenemark, & Ånell, 1996)
- Shoulder flexion angles less than 25 degrees (Chaffin & Andersson, 1984)
- Wrist flexion angles less than 30 degrees (Hedge, McCrobie, & Morimoto, 1995, p. 3; Rempel & Horie, 1994; Weiss, Gordon, Bloom, So, & Rempel, 1995)
- Wrist extension angles less than 30 degrees (Hedge et al., 1995; Rempel & Horie, 1994; Weiss et al., 1995)
- Torso-to-thigh angles equal to or greater than 90 degrees (Chaffin & Andersson, 1984)

There is wide variation in the physical size of the working population. For example, there is a difference of 34 cm (13.4 in.) in stature between a small woman and a tall man in the anthropometric database used in this standard. Moreover, personal work styles, fluctuation in task content throughout the workday, and worker physiology all dictate variations in working posture. This combined variation of size and posture, if not accounted for in the design of equipment, results in a mismatch between the user and equipment and, in turn, inefficiencies in the work process (Chaffin, 1984) Such work inefficiencies can add as much as 22 % to task performance times (Dainoff, 1990).

These postural guidelines are appropriate for all users. Consequently, they may be used for guidance when the individual user is outside the range of sizes (5th percentile female to 95th percentile male dimensions) that the equipment specifications in this standard have been designed to accommodate. Appendix A describes the development of the anthropometric dimensions.

## 8.3 Design Specifications

### 8.3.1 GENERAL SPECIFICATIONS

This section presents design specifications applicable to all furniture components considered in the standard.

#### 8.3.1.1 Stability

Workstation furniture **shall**

- Be structurally rigid and stable under typical usage conditions
- Meet the current applicable requirements of ANSI/BIFMA X5.5-1998, *Desk Products—Tests*; ANSI/BIFMA X5.9-2004 *Lateral Files—Tests*; ANSI/BIFMA X5.3-1997, *Vertical Files—Tests*; *BIFMA CMD-1-2002*, and ANSI/BIFMA X5.1-2002, *General Purpose Office Chairs—Tests*

Users have the expectation that the workstation furniture and accessories will be stable and safe during use. Unstable furniture, especially when loaded with equipment, can present a hazard if people lean on, sit on, or push against it. Unstable work surfaces or chairs also may tip over or collapse if used to support the user during changes in posture.

For purposes of this standard, workstation furniture is deemed to meet this requirement if it at least meets the appropriate stability specifications described in ANSI/BIFMA X5.5-1998, *Desk Products—Tests*; ANSI/BIFMA X5.2-1989, *Lateral Files—Tests*; ANSI/BIFMA X5.3-1989, *Vertical Files—Tests*; and ANSI/BIFMA X5.1-1993, *General Purpose Office Chairs—Tests*.

### 8.3.1.2 Pinch Points

Pinch points, in which fingers, arms, and legs can be caught between movable surfaces or parts, **shall**

- Be avoided by means of design or guarding

Adjustable workstation furniture surfaces move relative to one another. This may lead to pinch point hazards in which fingers, arms, and legs can be caught between moving surfaces or parts. This can occur, for example, when a motorized work surface moves past a fixed surface or when clearance between a seat adjustment lever and the bottom of the seat is inadequate. The size of the clearance gap necessary to avoid pinch points will depend on which limb might be involved, but it can be determined with reference to the appropriate 95th percentile male dimensions.

### 8.3.1.3 Workstation Adjustments

Furniture adjustment controls **shall not**

- Interfere with users' work activities or pose hazards during use

These controls **should**

- Be usable by users while in the relevant reference postures

Adjustability of workstation furniture is important for supporting postural changes during a work session as well as for supporting different users of the same workstation. Compared with hidden or obscure controls, controls that are easy to locate and easy to operate tend to be used more often (Lueder, 1994; Shute & Starr, 1984), which, in turn, facilitates frequent postural changes (Kleeman & Prunier, 1980; Winkle & Oxenburgh, 1990). Maintenance-adjustable controls, which require special tools and/or training to operate, are not effective in meeting the objectives of this standard when workstations are used for extended periods or by more than one individual. (See also Section 5.2.1.2, Adjustment Controls in the Workstation.)

### 8.3.1.4 Finish of Furniture and Accessories

All work surface edges on which the user is expected to rest the forearm or wrist **shall**

- Have radii of at least 3 mm

Other/Secondary user contact edges of the work surface **shall**

- Have radii of at least 2 mm

It is good ergonomic practice to avoid potential postural hazards or discomfort to users posed by sharp corners and edges on furniture surfaces. This may be accomplished by providing edges and corners with the largest radii possible. Work surfaces and adjustment controls that come into direct contact with the user require a larger (3 mm) minimum radius.

### 8.3.1.5 Surface Gloss

Surfaces such as equipment covers, furniture, and so forth **should**

- Have a matte finish that provides a specular reflectance of no more than 45 gloss units at an angle of 60 degrees as measured with instruments and procedures that conform to ASTM D523-89 (1999), Standard Test Method for Specular Gloss (American Society for Testing and Materials, 1999).

Glossy surfaces reflect light from lighting fixtures, windows, monitors, and so forth, which may cause visual discomfort to the operator and/or adversely affect performance.

## 8.3.2 SURFACES

### 8.3.2.1 Operator Clearances

Operator clearance spaces under all working surfaces (i.e., primary work surface, display support surface, input-device support surface) **shall** accommodate at least two of the three seated reference working postures, of which one must be the upright seated posture, by utilizing Method 1 or Method 2 as described below

For seated work, the clearance dimensions **shall**

- Provide the minimal clearance space labeled as Clearance Space 1 in Figure 8-3 for all workstations
- Provide the additional clearances illustrated in either Clearance Space 2 or 3 in Figure 8-3
- Comply with the dimensions given below for either Method 1 or Method 2

#### 8.3.2.1.1 *Method 1—Reclined Seated and Upright Seated Postures*

Method 1 defines the required operator clearances for the intended users in workspaces designed to accommodate only the upright and reclined seated reference postures. The intended users range from 5th percentile females to 95th percentile males. Figure 8.3a illustrates the clearance space specified by Method 1.

- 52 cm (20.5 in.) wide
- 44 cm (17.3 in.) deep at the level of the knee
- 60 cm (23.6 in.) deep at the level of the foot
- Adjustable between 50 and 69 cm (19.7 and 27.2 in.) in height at the edge of the work surface closest to the operator
- Adjustable between 50 and 64 cm (19.7 and 25.2 in.) in height at the horizontal position of the knee
- At least 10 cm (3.9 in.) in height at the position of the foot

The upper limit of the height adjustability range at the forward edge of the work surface is based on thigh clearance requirements of a horizontal seat pan angle. The upper limit of the height adjustability range at the level of the knee is based on height of the knee while seated. The lower limit of the height adjustability range is based on the height of the knee while seated. The width requirement is based on 95th percentile female hip breadth 7 cm allowance. The anthropometric basis for these requirements is contained in Appendix A.

#### 8.3.2.1.2 *Method 2—Upright, Reclined, and Declined Seated Postures*

Method 2 defines the required operator clearances for the intended users in workspaces designed to accommodate the declined seated reference postures where the intended users range from 5th percentile females to 95th percentile males. As Method 2 describes the largest operator clearance space, any operator clearance space that meets the specifications of Method 2 will automatically meet the operator clearance space specifications for upright seated and reclined seated postures. Figure 8.3b illustrates the clearance space specified by Method 2.

- 52 cm (20.5 in.) wide
- 44 cm (17.3 in.) deep at the level of the knee
- 60 cm (23.6 in.) deep at the level of the foot
- Adjustable between 50 and 72 cm (19.7 and 28.3 in.) in height at the edge of the work surface closest to the operator
- Adjustable between 50 and 64 cm (19.7 and 25.2 in.) in height at the horizontal position of the knee
- At least 10 cm (3.9 in.) in height at the position of the foot

The upper limit of the height adjustability range at the forward edge of the work surface is based on thigh clearance requirements of a forward declined seat pan angle of 4 degrees. The upper limit of the height adjustability range at the level of the knee is based on the height of the knee while seated. The lower limit of the height adjustability range is based on the height of the knee while seated. The width requirement is based on 95th percentile female hip breadth plus a clothing allowance. The anthropometric basis for these requirements is contained in Appendix A. The clearance spaces can be visualized as “boxes” inserted under the surface.

The clearance envelope must provide space for the operator’s thighs, knees, lower legs, and feet under the work surface while allowing support surfaces to be low enough for input device and visual display use (Grandjean et al., 1983; Kroemer, 1981). Pheasant (1986) defined clearance as one of the cardinal ergonomic requirements. The purpose of the lower limit on the range of height adjustability is to provide work surfaces that allow the operator to achieve working postures within the horizontal work envelope (see Section 5.2.4.1, Horizontal Work Envelope).

Figures 8-2, 8-3a and 8-3b show the orientation and dimensions of the clearance spaces under the work surface.

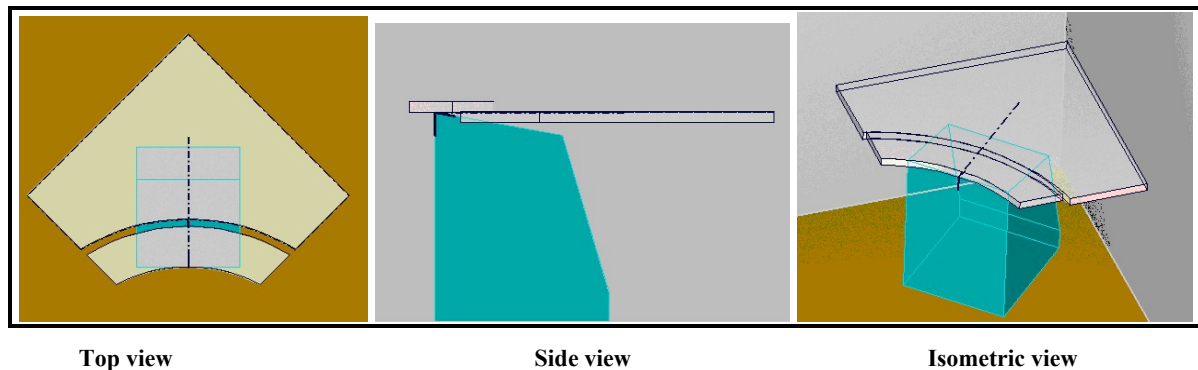

**Figure 8-2. Placement of clearance space boxes**

(23.6 in)

Figure 8.3a Illustration of the Clearance Spaces Used in Method 1 (8.3.2.1.1)

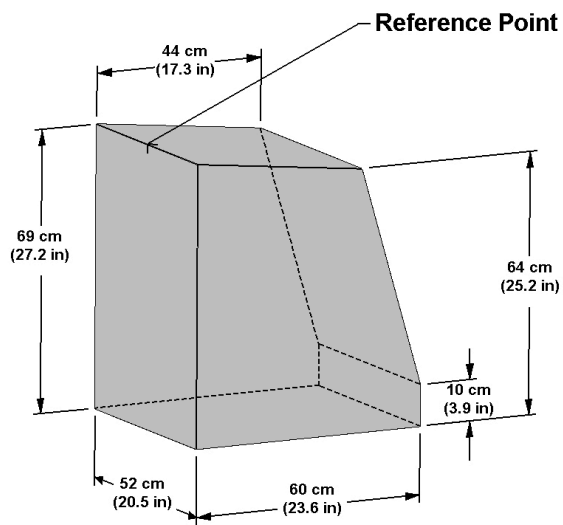
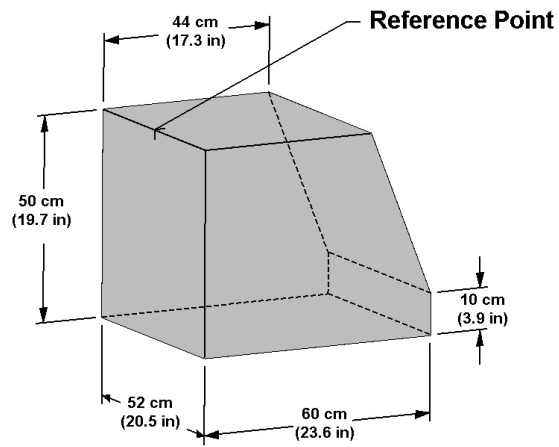
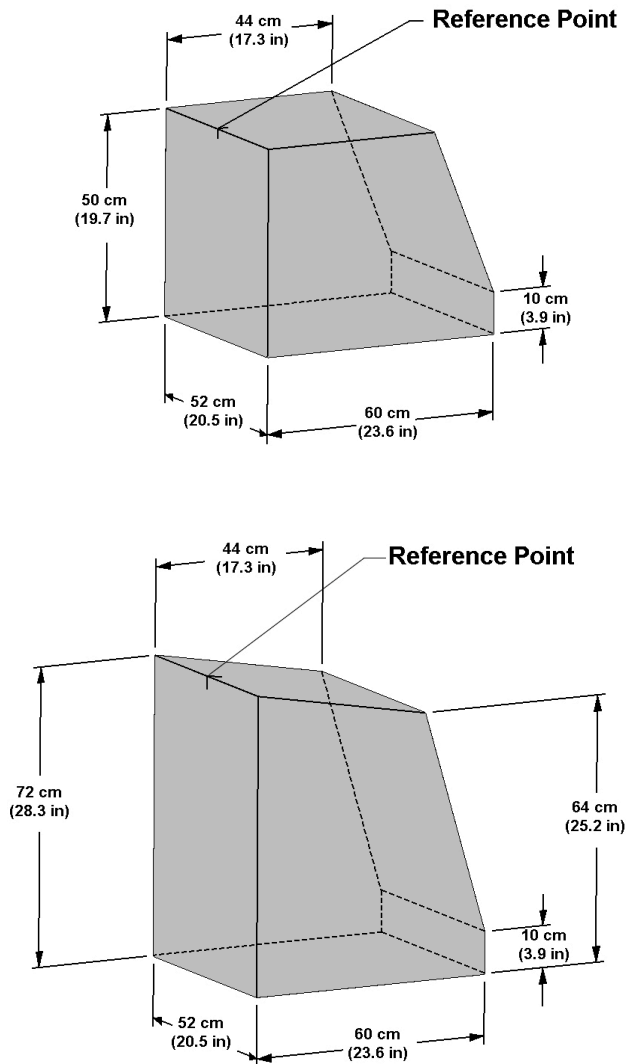



Figure 8.3b Illustration of the Clearance Spaces Used in Method 2 (8.3.2.1.2)



### 8.3.2.2 Work Surfaces

The work surface **should**

- be at least 70 cm (27.6 in.) wide

The depth of the work surface **should**

- Allow a viewing distance of at least 50 cm (19.7 in.)
- Allow positioning of the monitor so that the angle between the horizontal level of the eyes and the center of the screen ranges between 15 and 25 degrees
- Allow positioning of the entire viewing area (e.g., including the keyboard) in an arc 60 degrees below horizontal eye level

A minimum workstation width of 70 cm (27.6 in.) is based on the forearm-to-forearm breadth of a 95th percentile male user with the addition of an 8.5-cm (3.3-in.) margin for postural adjustment

(Gordon et al., 1989). This is strictly an anthropometric requirement. In fact, the functional requirements of the task will most likely dictate a larger width. The overall area of the work surface required depends on the size and number of components in the workstation in addition to the monitor and keyboard, including books, papers, and telecommunication equipment.

### 8.3.2.3 Monitor Support Surface/Device

The monitor support surface manufacturer **shall**

- Specify the size and weight of monitor that can be accommodated by the support surface because monitor support surfaces may not be compatible with certain-sized monitors
- Specify the range of adjustment if the support surface is adjustable

The support surface **should**

- Be designed so as to allow placement of the viewing area of the screen at a minimum viewing distance of 50 cm (19.7 in.)
- Be designed so as to allow placement of the monitor's viewing area below the user's horizontal eye height
- Be stable during use
- Not interfere with the user's ability to adjust the height, tilt, and rotation of the monitor

There are a number of devices for supporting a monitor or monitors. The monitor may rest on the work surface, or it can be supported by an articulated platform attached to the work surface, other workstation components or a fixed platform resting on the work surface. The monitor may also be supported by a separately adjustable work surface or by a platform built into the work surface but at a different level. Placement of the monitor is dependent on a variety of factors, including visual display factors, the user's optical correction (if present), the size and shape of the monitor, and the effort required by the user to activate adjustment controls. The proper location of larger monitors with respect to viewing distance and angle may be particularly problematic. Accordingly, the manufacturers of monitor support surfaces are responsible for specifying the characteristics of monitors that are compatible with their products.

### 8.3.2.4 Input-Device Support Surface

Input-device support surfaces may be designed for use while seated only, standing only, or while seated or standing. The reader's attention is directed to the requirements for placement of input devices within the recommended space specified in Section 5.2.3.4.

All input-device support surfaces **shall**

- Adjust in height, or a combination of height and tilt

The manufacturer of an input-device support surface **shall**

- Provide information regarding the range of height adjustment
- Provide information regarding tilt adjustments

All input-device support surfaces **should**

- Adjust fore and aft in the horizontal plane
- Adjust in side-to-side placement within the optimal area for input devices
- Tilt

#### **8.3.2.4.1 Sit-Only Working Postures**

The installed input-device support surface designed for sitting working postures only **shall**

- Comply with the clearance requirements specified in Section 8.3.2.0
- Have a surface height adjustment that includes at least the range of 56 cm to 72 cm (22 to 28.3 in.) as measured from the floor to the top of the surface.

If tilt adjustable, the tilt adjustment **should**

- Provide tilt adjustment to include the range between –15 degrees and +20 degrees including 0 degrees

#### **8.3.2.4.2 Stand-Only Working Postures**

If height adjustable only, the installed input-device support surface designed for standing work postures only **shall**

- Place the support surface at standing elbow height by adjusting in height between 95 cm and 118 cm (37.4 and 46.5 in.) as measured from the floor to the surface at the front edge of the support

Or, if both height and tilt adjustable, the input-device support surface **shall**

- Provide height adjustment to include some portion of the range between 78 cm and 118 cm (30.7 and 46.5 in.) and to include height adjustability in the range 89 cm to 110 cm (35 to 43.3 in.) as measured from the floor to the surface at the front edge of the support
- Provide tilt adjustment to include some portion of the range between 20 and –45 degrees, including the range 0 to –15 degrees
- Combine height and tilt within the specified ranges as defined by Equation 8-1

If tilt adjustable, input-device support surfaces designed for standing-work postures only **should**

- Allow tilt adjustment that includes the range between –45 degrees and +20 degrees
- Allow height adjustment that includes the entire range between 78 cm and 118 cm (30.7 and 46.5 in.) as measured from the floor to the surface at the front edge of the support

Standing input-device support surface height + sin (elbow angle relative to horizontal) x elbow-wrist length

$$A + \sin (B) \times C = \text{input device height} \quad (8-1)$$

(Add product of sin (B) and elbow-wrist length to standing elbow height if angle is positive; subtract if angle is negative)

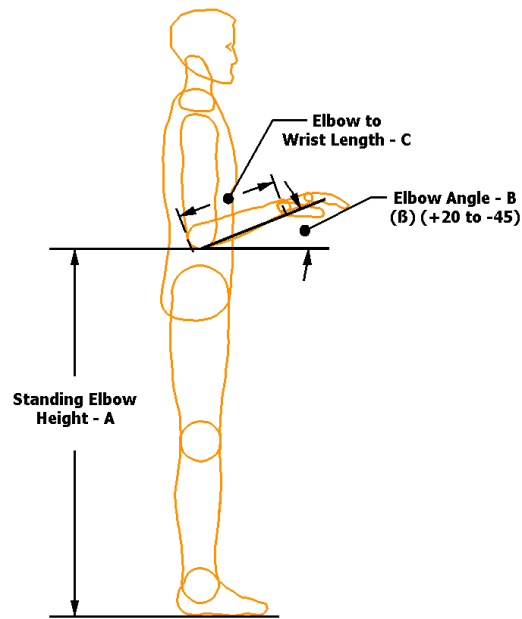

**Figure 8-4. Method of combining height and tilt for input-device support surfaces**

Height adjustment, or a combination of height and tilt adjustment, is necessary to successfully accommodate the desired range of users. The interaction between height and tilt is illustrated in Figure 8-4. Acceptable height and tilt angle combinations may be calculated according to the procedures described in Appendix A. Tilt angles greater than 20 degrees above horizontal or more than 45 degrees below horizontal are not acceptable.

#### **8.3.2.4.3 *Sit/Stand Working Postures***

If height adjustable only, the input-device support surface designed for both sitting and standing work postures **shall**

- Adjust in height between 56 cm and 118 cm (22 and 46.5 in.) as measured from the floor to the surface at the front edge of the support.
- Comply with the clearance requirements specified in Section 8.3.2.1 when used in the seated position

If height and tilt adjustable, the input-device support surface designed for both sitting and standing work postures **shall**

- Accommodate seated workers by adjusting in height in some portion of the range between 56 cm and 72 cm (22 and 28.3 in.) as measured from the floor to the surface at the front edge of the support
- Accommodate standing workers by providing additional height adjustability (greater than 72 cm [28.3 in.]) when combined with tilt as described in Equation 8-1
- Adjust in tilt in some portion of the range between +20 and -45 degrees, to include 0
- Comply with the clearance requirements specified in Section 8.3.2.1 when used in the seated position

A seated 5th percentile female will be accommodated at the 56 cm height and 0 degree tilt angle. A standing 95th percentile male will be accommodated at a 96 cm height with a surface that is tilted 45 degrees below horizontal; see Figure 8-4. Tilt angles greater than 45 degrees below horizontal are not acceptable.

The location of the input device on its support surface is a complex issue that integrates the recommended positions of the shoulder, upper arm, elbow, forearm, wrist, and hand with provision of clearance space for the legs underneath. Height and/or tilt adjustments are necessary to accommodate different sizes of workers and different working postures. Moreover, height and tilt requirements interact. These issues can be jointly addressed by an input-device support surface that supports placement of the input device or devices within a three-dimensional space or volume. Such an input-device support surface benefits from adjustability in both height and tilt. (See Section 5.2.4 for specification of the location of input devices relative to the user.)

Research suggests that input devices are most comfortable to use, and place less demand on the shoulder, when they are located so as to minimize shoulder abduction (Harvey & Peper, 1997; Karlqvist et al., 1996; Paul & Nair, 1996). This is achieved when the devices are located approximately within the shoulder span of the user and within forearm reach. Similarly, users report equal comfort and productivity for a wide range of elbow angles (Cushman, 1984; Grandjean et al., 1983; Miller & Suther, 1981; Weber et al., 1984). Tilting support surfaces for input devices facilitates neutral wrist postures (Berqvist, Wolgast, Nilsson, & Voss, 1995; Hedge, Morimoto, & McCrobie, 1999; Hedge & Powers, 1995).

Research supports the benefits of alternating between seating and standing postures (Dainoff, Paasche, Simons, & Terlaga, 1999; Nerhood & Thomson, 1994; Paul & Helander, 1995). Accordingly, the standard specifies minimum height and tilt adjustment ranges for sit/stand input-device support surfaces. Finally, research indicates that placement of input devices at multiple levels represents a viable solution to the location of multiple input devices within the recommended space (Paul & Nair, 1996). However, care must be taken that the postural design criteria of Section 5.2.1.1 are followed when multi-tiered input-device supports are used.

### 8.3.2.5 Standing Operator Foot Clearances

Clearance for users' feet under a stand-up work surface **should** be at least

- 10 cm (3.9 in.) in height
- 51 cm (20.1 in.) in width
- 10 cm (3.9 in.) in depth

Providing a foot clearance envelope allows the feet to move and assume different positions and postures. The stated height and depth allow the toes to be placed at least slightly under the work surface (Kroemer, 1981, 1991b). The height is based on the distance from the floor to the lateral malleolus (anklebone) of the 95th percentile male. The width is based on the hip breadth of a 95th percentile female plus a correction factor for variations in standing posture.

Providing foot clearance allows operators to stand near the stand-up workstations. The stated dimensions are based on published workplace data on shod foot dimensions and stance (Rhys & Konz, 1994). These authors also provided evidence for the beneficial effects of a footrest placed at a height of 10 cm.

## 8.3.3 SEATING

### 8.3.3.1 Height

The minimum range of seat height adjustment **shall**

- Be adjustable by the user over a minimum range of 11.4 cm (4.5 in.) within the recommended range of 38 to 56 cm (15 to 22 in.)

The manufacturer **shall**

- Provide information to show which of the three seated postures the chair will accommodate

Seat height is determined by a combination of chair dimensions (seat pan depth, seat pan angle) and anthropometric dimensions (popliteal height, buttock-knee length, buttock-popliteal length). Appendix A contains the anthropometric models and detailed rationale for these values. It should be pointed out that, for reasons relating to mechanical constraints on existing adjustment mechanisms, the required 11.4-cm seat height adjustment range does not accommodate the entire user population specified in Section 8.1.

### **8.3.3.2 Depth and Front Edge of the Seat Pan**

The seat depth **shall**

- If nonadjustable, be no greater than 43 cm (16.9 in.)
- Include 43 cm (16.9 in.) if adjustable

The front edge of the seat pan **should**

- Be rounded

An appropriate seat depth allows the user's back to be in full contact with the backrest while preventing contact between the back of the knee and the front of the seat pan. For nonadjustable seat depths, this is achieved by setting the maximum depth to the length of the small female (5th percentile) buttock-popliteal length, less a 1-cm margin. Rounding the front edge of the seat pan helps avoid undue pressure on the underside of the thigh (Chaffin & Andersson, 1991).

### **8.3.3.3 Seat Pan Width**

The seat pan **shall**

- Be at least 45 cm wide (17.7 in.)

The hip breadth of a 95th percentile female defines the minimum width of 45 cm to accommodate the user's thighs, including clothing (Gordon et al., 1989).

### **8.3.3.4 Seat Pan Angle**

The seat pan **shall**

- Have a user-adjustable range of at least 4 degrees, which includes a reclined position of 3 degrees

NOTE: User adjustment is defined as any method of activating the movement of the seat pan/backrest. This can be either through the use of manual devices (levers, knobs, adjustments, etc.) or by movement of the body.

Studies point out the advantages of adjustability of seat pan angles in either reclined backrest, declined seat pan, or upright postures (Grandjean et al., 1983; Mark, Dainoff, Moritz, & Voegelé, 1991). However, these studies do not specify exact limits of seat pan angle adjustability. The values selected are based on industry practice.

### 8.3.3.5 Seat Pan–Backrest Angle

The backrest **shall**

- Be able to achieve a position that is vertical or to the rear of vertical.

If the backrest is adjustable, it **shall**

- Have an adjustment range of 15 degrees or more within the range of 90 degrees and 120 degrees relative to horizontal

If the backrest recline angle exceeds 120 degrees from the horizontal, the backrest **should**

- Have a headrest, preferably user adjustable

An angle of less than 90 degrees between trunk and thighs may lead to fatigue or discomfort. Studies have shown that a recline-angle of 30 degrees from vertical reduces fatigue (Andersson, 1987; Andersson, Murphy, Ortengren, & Nachemson, 1979). If the backrest is reclined more than 30 degrees from vertical and there is no headrest, the user is forced to maintain the head in a static position. This may result in fatigue.

### 8.3.3.6 Backrest Height and Width

The top of the backrest **should**

- Be at least 45 cm (17.7 in.) above the compressed seat height

If fixed, the lumbar support area of the backrest **should**

- Be located between 15 and 25 cm (5.9 and 9.8 in.) above the compressed seat height

The position of the center of the lumbar support **should**

- Be user adjustable between 15 and 25 cm (5.9 and 9.8 in.) above the compressed seat height

The width of the backrest **should**

- Be at least 36 cm (14.2 in.)

A high backrest provides support to the thoracic spine in addition to supporting the lumbar spine. This allows the user to lean back in the chair to reduce compressive loading of the spine. For this purpose, the backrest must be sufficiently tall and wide (Andersson, 1987; Andersson et al., 1979; Andersson & Ortengren, 1974; Dowell, 1995; W. F. Floyd & Roberts, 1958; W. S. Floyd & Ward, 1969; Grandjean et al., 1983; Knutsson, Lindh, & Telhag, 1966).

## 8.3.4 USER SUPPORTS

### 8.3.4.1 Armrests

Armrests **should**

- Adjust in height from 17 to 27 cm (6.7 to 10.6 in.) above the compressed seat pan height
- Be designed to distribute forces evenly over the contact area
- Not create excessive pressure points
- Not irritate or abrade the skin
- Be able to be detached from the chair if necessary to fit the workplace

Fixed-height armrests **should**

Be between 18 and 27 cm (7.1 to 10.6 in.) above the compressed seat pan height

The clearance between armrests **should**

- Be at least 46 cm (18.1 in.)
- Be adjustable by the user (for example, pivot or otherwise move)

Armrests can increase the user's comfort. An adjustable armrest allows the user to enter and exit the chair easily. The range of armrest heights specified above is determined by the elbow rest heights of the 5th percentile female and the 95th percentile male. The clearance between armrests is determined by the hip breadth of the 95th percentile female with an additional clothing and movement allowance of 1 cm (Gordon et al., 1989).

### 8.3.4.2 Wrist/Palm, Forearm Supports

The shape and firmness of the rest **should**

- Facilitate attaining user wrist posture criteria (Section 8.2.1)
- Be designed to distribute forces evenly over the contact area
- Maintain a good thermal balance
- Not create excessive pressure points
- Not be so soft as to limit hand movement
- Not irritate or abrade the skin
- Not be less than 3.8 cm (1.5 in.) in depth

Rests for the wrist/palm and forearm have been shown to reduce muscle activity and to facilitate more neutral wrist angles when used appropriately (Albin, 1997; Damann & Kroemer, 1995; Feng, Grooten, Wretenberg, & Arborelius, 1997; Grandjean, 1987; Paul & Menon, 1994). Non-neutral wrist postures place stress on the internal structures of the wrist (Armstrong & Chaffin, 1978) and may increase internal wrist pressures (Hedge & Powers, 1995; Rempel, Bach, Gordon, & So, 1998; Rempel & Horie, 1994) to a level that adversely affects nerve function (Lundborg, Gelberman, Minteer-Convery, Lee, & Hargens, 1982).



### 8.3.4.3 Footrests

In order to provide support for placement of feet, a footrest for seated work **should**

- Be at least 51 cm (20.1 in.) wide and 20 cm (7.9 in.) deep
- Be height-adjustable up to 22 cm (8.7 in.) and may be adjustable in angle

Proper foot support reduces pressure to the underside of the thigh (Bush, 1969). Footrests allow users to maintain foot support under various seat height and work surface–height conditions (Burandt & Grandjean, 1963; Grandjean, 1987). A fairly large support surface is needed because small surfaces, such as bars, restrict foot placement and can increase muscle tension. Rhys and Konz (1994) demonstrated that a flat 10-cm-high footrest for standing workstations improved working posture and increased comfort. Other dimensions are based on professional judgment.

## 8.4 Conformance

This chapter provides conformance requirements and recommendations for suppliers and system integrators of computer workstations.

### 8.4.1 SUPPLIER CONFORMANCE

#### 8.4.1.1 Surfaces

The method of assessing clearances under surfaces involves constructing boxes with the outside dimensions shown in Figures 8-3a and 8-3b and assessing whether or not they are accommodated underneath the surface. For surfaces utilizing Method 1, boxes corresponding to those shown in Figure 8.3a are required. For Method 2, boxes corresponding those shown in Figure 8.3b are required.

In order to evaluate the conformance of a surface to the required clearance for Method 1:

1. Place furniture on a flat surface.
2. Determine intended computer display and keyboard location(s).
3. Adjust the top of the input-device surface to 56 cm (22 in.).
4. Place the small-seated operator clearance box (Small-5<sup>th</sup> Percentile box) under the surface, lining up the centerline of the box under the forward edge and center point of the surface. See Figure 8-3a.
5. Check for interference.
6. Determine intended computer display and keyboard location(s).
7. Adjust the top of the input-device surface to 69 cm (27.2 in.).
8. Place the clearance Large-95 %ile Male box under the surface, lining up the centerline of the box under the forward edge and center point of the surface. See Figure 8-3a.
9. Check for interference.

In order to evaluate the conformance of a surface to the required clearance for Method 2:

1. Place furniture on a flat surface.
2. Determine intended computer display and keyboard location(s).
3. Adjust the top of the input-device surface to 56 cm (22 in.).

4. Place the small seated operator clearance box (Small – 5<sup>th</sup> %ile Female) under the surface, lining up the centerline of the box under the forward edge and center point of the surface. See Figure 8-3b.
5. Check for interference.
6. Determine intended computer display and keyboard location(s).
7. Adjust the top of the input-device surface to 78 cm (30.7 in.).
8. Place the Large – 95<sup>th</sup> %ile Male box under the surface, lining up the centerline of the box under the forward edge and center point of the surface. See Figure 8-3b.
9. Check for interference.

#### 8.4.1.2 Seating

For seating product conformance, BIFMA/CMD-1-2002, *Universal Measurement Procedure for the Use of BIFMA Chair Measuring Device (CMD)* (BIFMA, 2002), **shall** be used. BIFMA is the Business and Institutional Furniture Manufacturer’s Association.

The intent of the BIFMA/CMD-1-98a procedure is to allow a chair to be considered “in conformance” if the chair can be adjusted to meet the requirements of this standard.

The BIFMA/CMD-1-2002 procedure provides for measurements outside the scope of this standard. Only the measurements within this standard are required for conformance. However, care must be taken when following the BIFMA/CMD-1-2002 procedure because it is intended to be performed sequentially. Skipping portions of the BIFMA/CMD-1-2002 procedure may leave the Chair Measuring Device in the incorrect setup position for the next measurement.

The measurements taken by means of the CMD procedure are in some cases dependent on the initial setup conditions and/or acceptable zones that are specified in this standard. The CMD procedure allows for the inclusion of these parameters in the measurements.

The acceptable zones for use with the BIFMA/CMD-1-2002 procedure as defined by this standard are as follows:

- Lumbar support height zone: 15 to 25 cm (5.9 to 9.8 in.)
- Arm rest zone: Use CMD acceptable zone
- Seat width zone: Use CMD acceptable zone

All other acceptable zones are defined in the BIFMA/CMD-1-2002 procedure.

In order for measurements to be acceptable, only CMDs built to BIFMA’s specifications can be used. BIFMA’s CMD is a patented device. Specifications and devices are available from BIFMA.

It is intended that the measurements taken in this procedure be performed sequentially—that is, the position a chair is in at the end of the measurement process in any given section will be the starting position for the subsequent section(s).

## **Appendix A (INFORMATIVE)**

### **A.1 Anthropometric Derivations**

This appendix describes the anthropometric basis and justification for design specifications contained in this standard. The general intent of the standard is to accommodate a range of users encompassing the 5th percentile female through the 95th percentile male dimensions.

#### **A.1.1 ANTHROPOMETRIC DATA**

The anthropometric database utilized is taken from an extensive survey of U.S. Army personnel (Gordon et al., 1989). Because of the size and composition (gender and ethnicity) of this survey, it is considered to be the best available representation of the U.S. civilian population (Kroemer et al., 1994). Marras and Kim (1993) carried out a statistical comparison of the Army database against their own sample of 384 male and 124 female factory workers. They found that some of the anthropometric dimensions had significantly higher mean values for male factory workers compared with male soldiers. However, only one of the Marras and Kim differences relevant to the computations is utilized in this standard—abdominal extension—and this difference, although statistically significant, was only 0.3 cm. This would have a practically insignificant effect on the computations.

#### **A.1.2 UNIVARIATE DATA**

Accommodating the specified user population is straightforward in cases when workplace dimensions can be based on a single relevant anthropometric variable. For example, Section 8.3.3.1 specified that seat depth should be no longer than 43 cm. This specification is based on the anthropometric variable *buttock-popliteal length*.

In this case, the particular value used is that of the 5th percentile female with a 1-cm allowance for clearance between the back of the knee and the chair seat. This defines the maximum length that a seat pan can be without coming in contact with the back of the knees for the specified user population. If this seat pan dimension is adequate for a 5th percentile female, it will be adequate for all males and females having greater values of buttock-popliteal length.

#### **A.1.3 ADDING PERCENTILES**

There are, however, other workplace specifications for which looking up a single anthropometric value in a table does not provide the desired information. It is well known that adding percentile values (e.g., 5th or 95th percentile values) for multiple anthropometric variables will not necessarily result in values that accommodate the desired portion of the population. The smaller the positive correlation between such dimensions, and the more dimensions that are combined, the greater the problem (Robinette & McConville, 1982; Zehner, Meindl, & Hudson, 1993).

#### **A.1.4 UNIDIMENSIONAL DATA**

In some cases, multiple existing variables can be used to define a unidimensional variable. Examples of unidimensional variables include height, width, and depth. This approach is used in the Army database to calculate standing elbow rest height, in which three height-related variables are combined and percentiles are calculated for the new data. Some error may arise, particularly if the combined elements do not perfectly describe the desired dimension.

The Army database was utilized in developing the unidimensional models used in the standard that are described below. The new distributions that resulted were used to describe the unidimensional variables and to develop specifications. This procedure avoids the problem of inappropriate addition of percentile values for unidimensional variables.

For example, it was desired to calculate the distribution of the distance between the front surface of the abdomen and the front edge of the knee. This distance was called *knee depth length*. The method used involves subtracting abdominal extension depth from buttock-knee length for each individual male soldier in the database. As the maximum knee depth length for the specified population was required, it sufficed to obtain the 95th percentile value of this newly calculated anthropometric dimension, and one can be confident that a knee depth length of this dimension accommodates 95% of males. Because the knee depth length for females is less than that for males, it can also be stated that at least 95% of females would be accommodated.

NOTE: Because of differences in the manner in which abdominal extension depth and buttock-knee length are measured, the difference—knee depth—overestimates (conservatively) the actual dimension.

### **A.1.5 MULTIDIMENSIONAL DATA**

A more problematic situation arises when the desired specifications are multidimensional. Rather than being only length or width or depth, the desired model combines variables in two or more dimensions. An example is clearance space for the user's legs and feet under the work surface. Clearance space is a volume and hence requires combining three dimensions: height, width, and depth.

One might be tempted simply to combine the relevant unidimensional height, width, and depth parameters for each individual and develop a distribution. Unfortunately, this introduces too much uncertainty to be of use.

To understand this uncertainty, consider a hypothetical 95th percentile clearance space that is 50 cm high by 60 cm wide by 70 cm deep (0.21 cubic meters). Now consider three different individuals' clearance spaces, all of equal volume to this hypothetical 95th percentile clearance space. The first is 50 cm high by 60 cm wide by 70 cm deep; the second is 60 cm high by 50 cm wide by 70 cm deep; and the third is 70 cm high by 60 cm wide by 50 cm deep. Clearly, only the first individual is accommodated, even though the volume of the clearance space for all three equals the 95th percentile clearance space.

Although at first glance it might appear that choosing 95th percentile values for each of the three dimensions would accommodate 95% of the population, the situation is not so simple. This is the fallacy of adding percentiles. As was discussed previously, this would work only if the three variables were all perfectly positively correlated. If they are independent of one another (correlation equal to zero), then the percentage accommodated would actually be 0.95 raised to the third power, or about 85%. Consequently, if one knew that the three variables were independent, one could choose the 99th percentile value for each variable and then expect to accommodate slightly more than 95% (0.99 raised to the third power). If they were positively correlated, the percentage accommodated would be somewhat greater than 95%.

### **A.1.6 ITERATIVE SOLUTION TO CLEARANCE SPACE**

The clearance space under the work surface was modeled using multiple ANSUR anthropometric variables, which, except width, are shown in Figure A-1. Although multivariate approaches such as principal component analysis could be applied to solving the clearance space problem, a different approach was taken. Because the entire Army database was available as a computer file, it was possible, using an iterative process, to determine the actual joint percentile value that, when applied to each of the five variables, provided clearance for at least 95% of the user population.

An arbitrary percentile value (99th percentile) was chosen as a starting value. The Army data were then examined for all variables in the model to determine the actual percentage accommodated on all the variables. If the percentage accommodated on all variables was greater than 95%, the percentile value was decreased and the percentage accommodated on all variables was again assessed. This process continued until a percentile value was found that accommodated at least 95% of all individuals

in the Army database. The specific values for each of the five variables were then used as the specification for the clearance space.

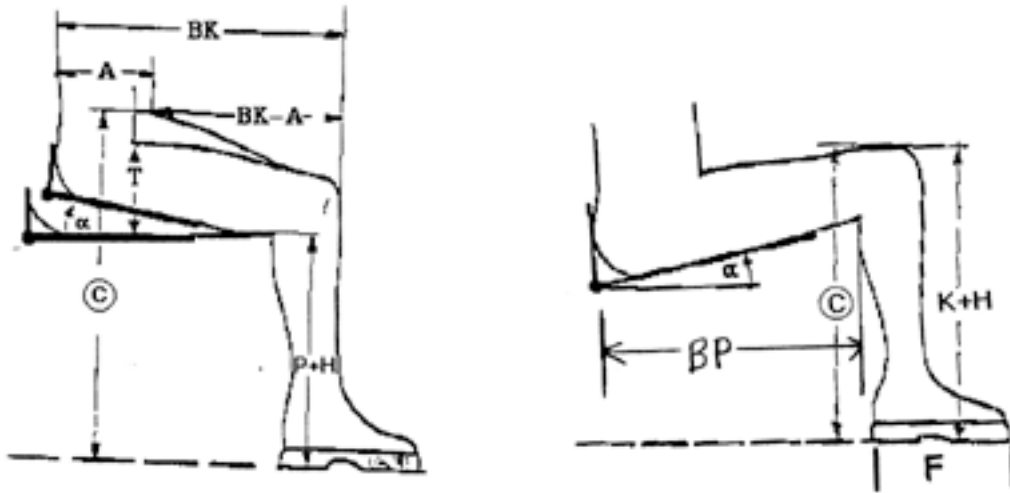

**Figure A-1. Clearance dimensions.** A = abdominal extension depth; H = heel height; F = foot length;  $\alpha$  = seat pan angle; K = knee height, sitting; SPD = seat pan depth; BP = buttock-popliteal length; BK = buttock-knee length; P = popliteal height; T = thigh clearance, sitting; C = clearance.

## A.2 Clearance Under the Work Surface

### A.2.1 DERIVING THE MODELS

Three of the variables (height range, knee depth, and foot depth) used to calculate clearance space was calculated as unidimensional variables by assembling sub-elements from the Army database and calculating new distributions. In addition, height range required identification of both upper (maximum) and lower (minimum) values to specify adjustment ranges.

#### A.2.1.1 Minimum Width

$$\text{Minimum width} = \text{Hip breadth} + 7 \text{ cm} \quad (\text{A-1})$$

The minimum clearance width based on hip breadth plus a 70 cm (2.8 in.) allowance for clothing, movement, and outward rotation of the legs in normal sitting.

#### A.2.1.2 Minimum Knee Depth

$$\text{Minimum knee depth} = \text{BK} - \text{A} \quad (\text{A-2})$$

The minimum leg depth at the level of the knee is based on the dimensions of buttock-knee length (BK) minus abdominal depth (A). This model assumes that the operator is working with his/her stomach against the forward edge of the work surface/keyboard support surface. This is a conservative assumption that provides some safety margin.

#### A.2.1.3 Minimum Foot Depth

$$\text{Minimum foot depth} = \text{BP} - \text{A} + \text{F} \quad (\text{A-3})$$

The minimum depth at the foot level is based on foot length (F) plus buttock-popliteal length minus abdominal extension depth. These values are measured with the lower leg perpendicular to the floor. If desired, the system installer can compute an additional allowance for 30-degree forward leg extension by multiplying augmented popliteal height (P + 2.5 cm shoe correction) by the sine of 30 degrees. As was the case for Equation A-2, the assumption that the operator works with his/her stomach against the forward surface provides a safety margin.

#### **A.2.1.4 Maximum Thigh Height**

$$\text{Maximum Thigh Height} = P + T + H + (\sin(\alpha) * (BK - AE)) \quad (\text{A-4})$$

[Constants: heel height (H) = 2.5 cm;  $\alpha$  = seat pan angle]

Equation A-4 depicts the model for maximum thigh height at the leading edge of the work surface. The model adds augmented popliteal height (P) and the heel height constant (H) to thigh clearance height (T). However, in addition, it is necessary to correct for seat pan angle. This correction involves multiplying the difference between buttock-knee length (BK) and abdominal extension depth (AE) by the sine of the seat pan angle. Declined seat pan angles have positive values; reclined seat pan angles have negative values. In the case of a declined seated reference posture, the largest declined angle ( $\alpha = 4$  degrees) is applied to Equation A-4. In the case of an upright-seated reference posture, the seat pan is horizontal ( $\alpha = 0$  degrees). The use of Equation A-4 for the reclined seated posture is not required because the maximum height is determined by knee height.

#### **A.2.1.5 Maximum and Minimum Knee Height**

$$\text{Knee height} = K + H \quad (\text{A-5})$$

[Constant: heel height (H) = 2.5 cm]

The maximum height at the level of the knee is determined to be the anthropometric dimension knee height with the addition of a heel correction for the 95th percentile male (tallest members of the accommodated group). It is independent of seat pan angle and therefore appropriate as a maximum for all three seated reference postures. The minimum height at the level of the knee is determined as the anthropometric dimension knee height with the addition of a heel correction for the 5th percentile female (smallest members of the accommodated group).

#### **A.2.1.6 Upper Limits**

The standard allows a choice between two methods of providing clearance space under the work surface. These choices depend on which of the three seated reference postures are utilized. Method 1 is designed to accommodate the reclined and upright seated postures, and Method 2 is designed to accommodate declined, reclined, and upright seated postures. In each method, both the minimum and maximum clearances must be accommodated.

##### ***A.2.1.6.1 Method 1—Upright and Reclined Seated Postures***

The following derived anthropometric variables were used in determining the Method 1 clearance space: minimum width, minimum knee depth, minimum foot depth, maximum thigh height, and maximum knee height. In the case of maximum thigh height (Equation A-5), the seat pan angle was assumed to be horizontal for upright sitting; thus,  $\alpha = 0$ . Because the position of the thigh moves downward in reclined sitting, it is not necessary to compute Equation A-4 with positive values of  $\alpha$ .

The corresponding dimensional value was obtained for each of the five variables at each step by starting with an initial percentile value of 99 and working downward in steps. The outcome of each step was a set of five “test specifications” (test values of minimum width, minimum knee depth, minimum foot depth, maximum thigh height, and maximum knee height). The test specifications were compared with the values of the corresponding variables for every male in the Army database. It was then possible to determine what percentage of males was accommodated by the test specifications. The process ceased when the percentage of the individuals accommodated by the test specification reached

95%. This occurred when the percentile value was equal to 97.6 and the corresponding clearance values were as follows:

Maximum thigh height	69 cm
Minimum knee depth	44 cm
Maximum knee height	64 cm
Minimum foot depth	60 cm
Minimum width	50 cm

The same iterative procedure was applied to the female database. For the first three variables given above, the female values were less than the male values. However, for minimum width, the female values were larger.

Accordingly, the final set of specifications involved repeating the procedure described above, except that now the female minimum width was compared against each of the male values of minimum width. The results indicated that female minimum width value accommodated 95% of the males. Thus, both males and females are successfully accommodated by this procedure. The final values for the clearance space dimensions that are used in this standard (Method 1) are

Maximum thigh height	69 cm
Maximum knee height	64 cm
Minimum knee depth	44 cm
Minimum foot depth	60 cm
Minimum width	52 cm

#### ***A.2.1.6.2 Method 2—Upright and Declined Seated Postures***

The procedures for determining clearances under Method 2 were the same as for Method 1 except that for maximum thigh height (Equation A-4), the seat angle,  $\alpha$ , was set equal to 4 degrees. This represents the upper level of seat pan angle for declined sitting. Clearances determined by this procedure will automatically accommodate upright sitting. The resulting values, which comprise the specifications for clearance space in this standard (Method 2), are as follows:

Maximum thigh height	72 cm
Maximum knee height	64 cm
Minimum knee depth	44 cm
Minimum foot depth	60 cm
Minimum width	52 cm

#### **A.2.1.7 Lower Limit**

The minimum height requirement represents the clearance requirement for the lower limit of the vertical range of adjustability of a work surface. This specification, which is based on augmented knee height, is met by applying Equation A-5 to the Army database for females and determining the 5th percentile value of the resulting distribution.

Minimum knee height	50 cm
---------------------	-------

### **A.3 Seat Height**

#### **A.3.1 DERIVING THE MODELS**

The general approach to establishing ranges of seat height adjustment contained in Section 8.3.3.1 is similar to that utilized in determining the maximum and minimum height for clearance discussed earlier.

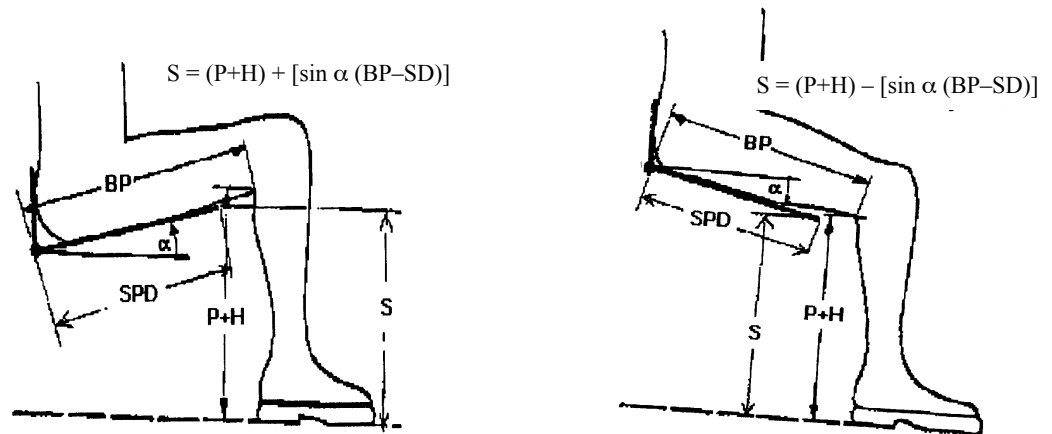

**Figure A-2. Seat height dimensions.** A = abdominal extension depth; H = heel height; S = seat height;  $\alpha$  = seat pan angle; K = knee height, sitting; SPD = seat pan depth; BK = buttock-knee length; P = popliteal height; BP = buttock-popliteal length; T = thigh clearance, sitting; C = clearance.

### A.3.1.1 Maximum Seat Height

$$\text{Maximum seat height} = P + H + (\sin \alpha (BP - SPD)) \quad (\text{A-6})$$

[Constants: heel height (H) = 2.5 cm; declined seat pan angle ( $\alpha$ ) = 4 degrees, seat pan depth (SPD) = 43 cm, sine 4 degrees = 0.0698]

The equation for maximum height is based on augmented popliteal height (P + H, including a heel height correction). However, in addition, it is assumed that the seat pan is in a 4-degree forward-tilt position. Accordingly, a correction is applied which takes into account the value of seat depth specified in Section 8.3.3.2 (see Figure A-2).

### A.3.1.2 Minimum Seat Height

$$\text{Minimum Seat Height} = P + H - (\sin \alpha)(BP-SPD) \quad (\text{A-7})$$

[Constants: heel height (H) = 2.5 cm; reclined seat pan angle ( $\alpha$ ) = -10 degrees, seat pan depth (SPD) = 43 cm]

The equation for minimum height is identical to Equation A-6. However, in this case, it is assumed that the seat pan is in a 10-degree backward recline, and an appropriate correction is applied (see Figure A-6).

In comparing Equations A-6 and A-7, it should again be noted that maximum height is defined by a situation in which the thigh is higher than the knee because of the declined seat pan. The angle of declination (4 degrees) is one extreme of seat pan angle, as specified in the standard. Minimum height, on the other hand, is defined by a reclined seat pan in which the thigh is lower than the knee.



### A.3.2 DEFINING ACCOMMODATION RANGES

As in the case of clearance, Equations A-6 and A-7 were applied to the appropriate Army database. Equation A-6, which defines maximum seat height, was applied to each member of the male Army database, and the 95th percentile value of the resulting distribution was determined. This value was found to be 51 cm. To this was applied a correction value of 5 cm. This correction is based on empirical literature, summarized by Cornell and Kokot (1994), which suggests that users tend to adjust their chairs higher than their popliteal heights.

Equation A-8, which defines minimum seat height, was correspondingly applied to each member of the female Army database. The 5th percentile value of the resulting distribution was found to be 37 cm. However, because of the minimum capabilities of current height adjustment mechanisms, this was increased to 38 cm.

## A.4 Standing and Sit-Stand Work Surfaces; Height and Angle Adjustments

### A.4.1 Deriving the Models

The envelope of acceptable forearm postures as specified in the standard ranges from 45 degrees below the horizontal to 20 degrees above the horizontal. In order to calculate work surface heights for standing and sit-stand situations, it was assumed that the upper arm remained vertical and the angle between the hand and the forearm is 180 degrees.

The following models define ranges of adjustability of keyboard support surfaces and working surfaces that accommodate these postural ranges. In each case, the models are based on two anthropometric dimensions; elbow rest height, standing (ERH), and elbow-wrist length (FL; see Figure 8-4). The basic height ranges are established by adding to or subtracting from ERH an amount equal to the sine of the forearm angle ( $\beta$ ) multiplied by elbow-wrist length for elbow angles other than 90 degrees.

#### A.4.1.1 Standing Support Surface Height

$$\begin{aligned} \text{Minimum support surface height} &= \text{ERH} - \sin \beta (\text{FL}) + H && \text{(A-8)} \\ [\text{Constants: heel height (H)} &= 2.5 \text{ cm; } \beta = \text{elbow angle (from horizontal)}] \end{aligned}$$

Within the recommended work region for input devices, elbow angle  $\beta$  ranges between +20 degrees above horizontal and -45 degrees below.

### A.4.2 DEFINING ACCOMMODATION RANGES

Equation A-8 was used to define the extremes of the envelope of positions for standing and sit-stand support surface heights and tilt angles. Each of the values in Table A-1 refers to 95th or 5th percentiles of the frequency distributions resulting from the applications of Equation A-8 to the male or female components of the Army database (Gordon et al., 1989). Values were obtained for elbow angles of -45, -30, -15, 0, and +20 degrees.

Because forearm length was not part of the Army database, the distribution was calculated by subtracting hand length from forearm-hand length for each individual in the Army database. The resulting values refer to surface heights and tilt angles that enable the recommended range postural angles to be achieved by large males and small females.

**Table A-1. Combinations of Elbow Angle and Surface Height**

Elbow Angle (degrees)	Male 95th percentile	Female 5th percentile
Maximum (+20)	128	104
Horizontal (0)	118	95
(-15)	110	89
(-30)	103	83
Minimum (-45)	96	78

## 8.5 References

- Albin, T. J. (1997). Effect of wrist rest use and keyboard tilt on wrist angle while keying. In *Proceedings of the 13th Annual Congress of the IEA* (Vol. 4, pp. 16–18). Helsinki: Finnish Institute of Occupational Health.
- American Society for Testing and Materials. (1999). *Standard test method for specular gloss* (designation D523-89 (1999), reapproved 1999). Conehocken, PA: Author.
- Andersson, G. B. J. (1987). Biomechanical aspects of sitting: An application to VDT terminals. *Behavior and Information Technology*, 6(3), 257–269.
- Andersson, G. B. J., Murphy, R. W., Ortengren, R., & Nachemson, A. L. (1979). The influence of backrest inclination and lumbar support on the lumbar lordosis in sitting. *Spine*, 4, 52–56.
- Andersson, G. B. J., & Ortengren, R. (1974). Myoelectric activity during sitting. *Scandinavian Journal of Rehabilitation Medicine* (Supplementum 3), 73–90.
- Armstrong, T. J., & Chaffin, D. B. (1978). An investigation of the relationship between displacements of the finger and wrist joints and the extrinsic finger flexor tendons. *Journal of Biomechanics*, 11, 119–128.
- Berqvist, U., Wolgast, E., Nilsson, B., & Voss, M. (1995). Musculoskeletal disorders among visual display terminal workers: Individual, ergonomic, and work organization factors. *Ergonomics*, 38, 736–776.
- Burandt, U., & Grandjean, E. (1963). Sitting habits of office employees. *Ergonomics*, 6, 217–226.
- Bush, C. A. (1969). Study of pressures on skin under ischial tuberosities and thighs during sitting. *Archives of Physical Medicine*, 50, 207.
- Business and Institutional Furniture Manufacturer's Association (BIFMA). (1998). *Universal measurement procedure for the use of BIFMA Chair Measuring Device (CMD)* (BIFMA/CMD-1-98a). Grand Rapids, MI: Author.
- Chaffin, D. B., & Andersson, G. (1984). *Occupational biomechanics* (2nd ed.). New York: Wiley Interscience.
- Cornell, P., & Kokot, D. (1994). Use of adjustable VDT stands in an office setting. In R. Lueder & K. Noro (Eds.), *Hard facts about soft machines: The ergonomics of seating* (pp. 47–58). London: Taylor & Francis.
- Cushman, W. H. (1984). Data-entry performance and operator preferences for various keyboard heights. In E. Grandjean (Ed.), *Ergonomics and health in modern offices* (pp. 495–504). Philadelphia: Taylor & Francis.
- Dainoff, M. (1990). Ergonomic improvements in VDT workstations: Health and performance effects. In S. Sauter, M. Dainoff, & M. Smith (Eds.), *Promoting health and productivity in the computerized office* (pp. 49–67). Philadelphia: Taylor & Francis.
- Dainoff, M. J., Paasche, J., Simons, K., & Terlaga, K. (1999). Periodic standing as a relief from fatigue in office work. In D. Alexander (Ed), *Applied ergonomics: Case studies II*. Norcross, GA: Institute of Industrial Engineers.
- Damann, E. A., & Kroemer, K. H. E. (1995). Wrist posture during computer mouse usage. In *Proceedings of the Human Factors and Ergonomics Society 39th Annual Meeting* (pp. 625–629). Santa Monica, CA: Human Factors and Ergonomics Society.
- Dowell, W. R. (1995). An estimation of lumbar height and depth for the design of seating. In *Proceedings of the Human Factors Society 39th Annual Meeting* (p. 409). Santa Monica, CA: Human Factors and Ergonomics Society.
- Feng, Y., Grooten, W., Wretenberg, P., & Arborelius, U. P. (1997) Effects of arm support on shoulder and arm muscle activity during sedentary work. *Ergonomics*, 40, 834–848.
- Floyd, W. F., & Roberts, D. F. (1958). Anatomical and physiological principles in chair and table design. *Ergonomics*, 2, 1–16.

- Floyd, W. S., & Ward, J. S. (1969). Anthropometric and physiological considerations in school, office and factory seating. In E. Grandjean (Ed.), *Sitting posture* (pp. 18–25). London: Taylor & Francis.
- Gordon, C. C., Churchill, T., Clauser, T. E., Bradtmiller, B., McConville, J. T., Tebbetts, I., et al. (1989). *1988 Anthropometric survey of U.S. Army personnel: Summary statistics interim report* (Tech. Report NATICK/TR-89-044). Natick, MA: U.S. Army Natick Research, Development and Engineering Center.
- Grandjean, E. (1987). *Ergonomics in computerized offices*. Philadelphia: Taylor & Francis.
- Grandjean, E., Hunting, W., & Pidermann, M. (1983). VDT workstation design: Preferred settings and their effects. *Human Factors*, 25, 161–175.
- Harvey, R., & Peper, E. (1997). Surface electromyography and mouse use position. *Ergonomics*, 40, 781–789.
- Hedge, A., McCrobie, D., & Morimoto, S. (1995). *Beneficial effects of a preset tiltdown keyboard system on posture and comfort in offices* [Monograph]. Ithaca, NY: Cornell University.
- Hedge, A., Morimoto, S., & McCrobie, D. (1999). Effects of keyboard tray geometry on upper body posture and comfort. *Ergonomics*, 42, 1333–1349.
- Hedge, A., & Powers, J. A. (1995). Wrist postures while keyboarding: Effects of a negative slope keyboard system and full motion forearm supports. *Ergonomics*, 38, 508–517.
- Karlvqvist, L. K., Hagberg, M., Köster, M., Wenemark, K. A., & Ånell, R. (1996). Musculoskeletal symptoms among computer assisted design (CAD) operators and evaluation of a self-assessment questionnaire. *International Journal of Occupational and Environmental Health*, 2, 185–192.
- Kleeman, W. B., & Prunier, T. (1980). Evaluation of chairs used by air traffic controllers of the U.S. Federal Aviation Administration. In R. Easterby, K. H. E. Kroemer, & D. Chaffin (Eds.), *NATO symposium on anthropometry and biomechanics: Theory and application* (pp. 235–239). London: Plenum.
- Knutsson, B., Lindh, K., & Telhag, H. (1966). Sitting—An electromyographic and mechanical study. *Acta Orthopaedica Scandinavica*, 37, 415–426.
- Kroemer, K. H. E. (1981). Engineering anthropometry: Designing the work place to fit the human. In *Proceedings, Annual Conference, American Institute of Industrial Engineers* (pp. 119–126). Norcross, GA: American Institute of Industrial Engineers.
- Kroemer, K. H. E. (1991a). Sitting at work: Recording and assessing body postures, designing furniture for computer workstations. In A. Mital & W. Karwowski (Eds.), *Work space, equipment and tool design* (pp. 93–109). Amsterdam: Elsevier.
- Kroemer, K. H. E. (1991b). VDT workstation design. In M. G. Helander (Ed.), *Handbook of human-computer interactions* (pp. 521–539). Amsterdam: North-Holland.
- Kroemer, K., Kroemer, H., & Kroemer-Elbert, K. (1994). *Ergonomics: How to design for ease and efficiency* (pp. 365–370). Englewood Cliffs, NJ: Prentice-Hall.
- Lueder, R. K. (1994). Adjustability in context. In R. K. Lueder & K. Noro (Eds.), *Hard facts about soft machines: The ergonomics of seating* (pp. 25–35). Philadelphia: Taylor & Francis.
- Lundborg, G., Gelberman, R., Minter-Convery, M., Lee, Y., & Hargens, A. (1982). Median nerve compression in the carpal tunnel-functional response to experimentally induced controlled pressure. *Journal of Hand Surgery*, 7, 252–258.
- Mark, L. S., Dainoff, M. J., Moritz, R., & Vogeles, D. (1991). An ecological framework for ergonomic research and design. In R. R. Hoffman & D. A. Palermo (Eds.), *Cognition and the symbolic processes* (Vol. 3, pp. 477–505). Hillsdale, NJ: Erlbaum.
- Marras, W. S., & Kim, J. Y. (1993). Anthropometry of industrial populations. *Ergonomics*, 36, 371–378.
- Miller, I., & Suther, T. W. (1983). Preferred height and angle settings of CRT and keyboard for a display station input task. In *Proceedings of the Human Factors Society 25th Annual Meeting* (pp. 492–496). Santa Monica, CA: Human Factors and Ergonomics Society.
- Nerhood, H. L., & Thomson, S. W. (1994). Adjustable sit-stand workstations in the office. In *Proceedings of the Human Factors Society 38th Annual Meeting* (pp. 668–672). Santa Monica, CA: Human Factors and Ergonomics Society.
- Paul, R., & Helander, M. G. (1995). Effect of sit-stand schedule on spinal shrinkage in VDT operators. In *Proceedings of the Human Factors Society 39th Annual Meeting* (p. 563). Santa Monica, CA: Human Factors and Ergonomics Society.
- Paul, R., & Menon, K. (1994). Ergonomic evaluation of keyboard wrist pads. In *Proceedings of the 12th Triennial Congress of the International Ergonomics Association* (Vol. 2, pp. 204–207). Toronto, International Ergonomics Association.

- Paul, R., & Nair, C. (1996). Ergonomic evaluation of keyboard and mouse tray designs. In *Proceedings of the Human Factors and Ergonomics Society 40th Annual Meeting* (pp. 632–636). Santa Monica, CA: Human Factors and Ergonomics Society.
- Pheasant, S. (1986). *Bodyspace: Anthropometry, ergonomics and design*. London: Taylor & Francis.
- Rempel D., Bach J., Gordon L., So, Y. (1998) "Effects of forearm pronation/supination on carpal tunnel pressure." *J Hand Surg [Am]*; 23: 1: 38-42.
- Rempel, D., & Horie, S. (1994). Effect of wrist posture during typing on carpal tunnel pressure. In *Proceedings of Working with Display Units '94* (pp. 27–28). Milan: University of Milan.
- Robinette, K. M., & McConville, J. T. (1982). An alternative to percentile models (SAE Tech. Paper 810217). In *1981 SAE Transcriptions* (pp. 938–946). Warrendale, PA: Society of Automotive Engineers.
- Sanders, M., & McCormick, E. J. (1993). *Human factors in engineering and design* (7th ed.). New York: McGraw-Hill.
- Shute, S. J., & Starr, S. J. (1984). Effects of adjustable furniture on VDT users. *Human Factors*, 26, 157–170.
- Weber, A., Sancin, E., & Grandjean, E. (1984). The effects of various keyboard heights on EMG and physical discomfort. In E. Grandjean (Ed.), *Ergonomics and health in modern offices* (pp. 477–483). Philadelphia: Taylor & Francis.
- Weiss, N. D., Gordon, L., Bloom, T., So, Y., & Rempel, D. M. (1995). Wrist position of lowest carpal tunnel pressure and implications for splint design. *Journal of Bone Joint Surgery*, 77A, 1695–1699.
- Winkel, J., & Oxenburgh, M. (1990). Towards optimizing physical activity in VDT/office work. In S. L. Sauter, M. Dainoff, & M. J. Smith (Eds.), *Promoting health and productivity in the office environment* (pp. 94–117). London: Taylor & Francis.
- Zehner, G. F., Meindl, R. S., & Hudson, J. A. (1993, April). *A multivariate anthropometric method for crew station design: Abridged* (Tech. Report AL-TR-1992-0164). Wright-Patterson Air Force Base, OH: Air Force Material Command, Armstrong Laboratory.